

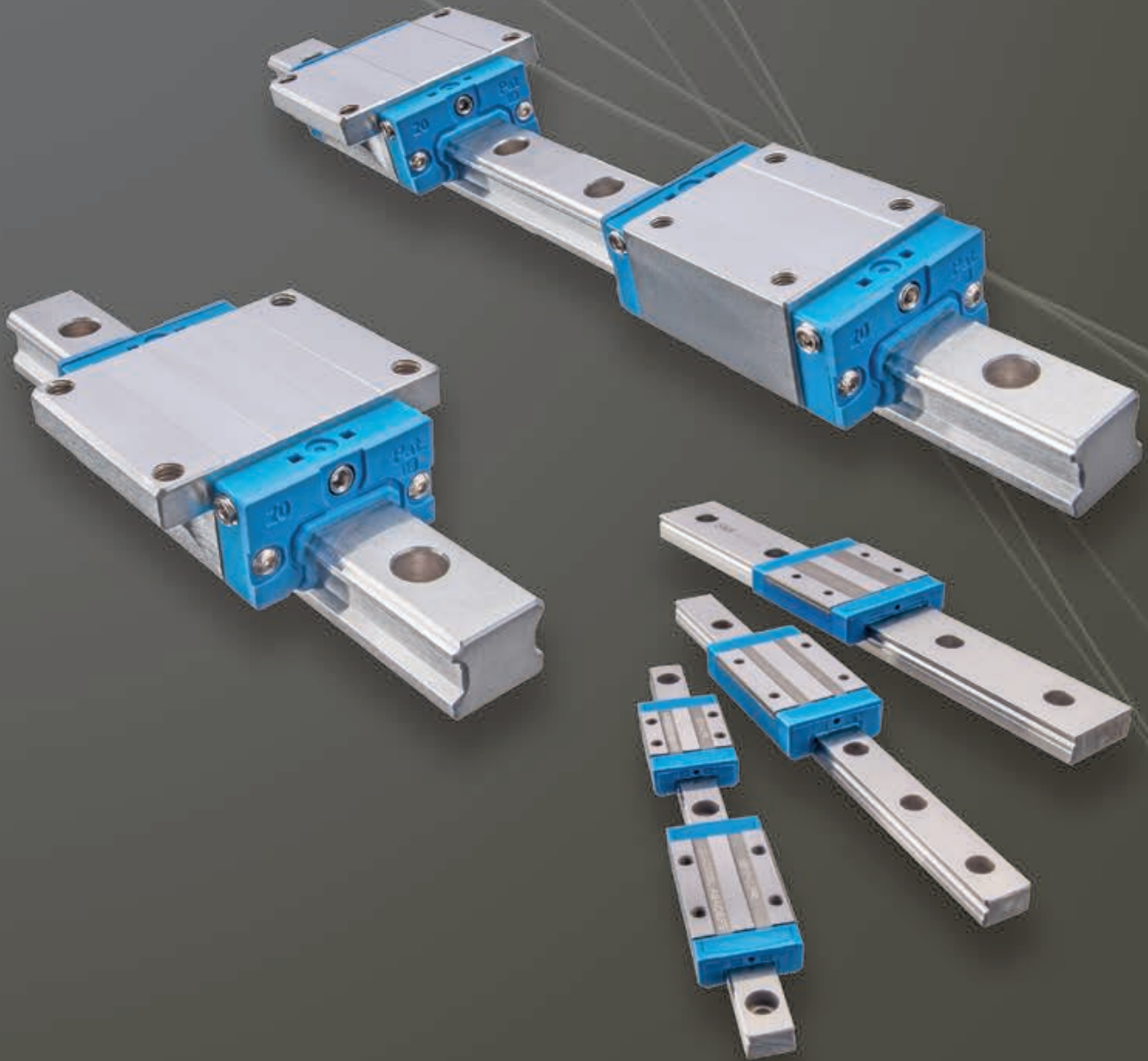
WE GET
YOU MOVING!



www.ntn-snr.com



With You



WE GET YOU MOVING...

NTN-SNR as part of the NTN Corporation has been one of the most innovative companies in this sector for decades. The NTN Group is one of the largest roller bearing manufacturer in the world.

This position allows us to provide our customers with a high level of added value regarding service, quality and product range. As a result, we have been able to build a strong image as a competent partner for our customers. Our companies are characterized by global presence and a consistent quality system.

NTN-SNR has been established in the linear technology market since 1985 and strives to offer a complete and competitive product range. This catalogue provides an overview of our profile rail range. This innovative range is based on a patented ball chain system and a broad product range. Our external long-term tests prove that our production strictly adheres to the high NTN-SNR quality standards. We also provide a wide range of technical innovations.

Our sales support and applications engineers are always on hand to you to offer you optimal support. Globally! Supplies from our European Warehouse in Germany ensure fast delivery.

Rail guides are used in a variety of applications such as: machine tool construction, packaging and printing machine construction, building of general and special machines, aeronautical construction, automation and assembly lines, the timber and semiconductor industries, medical technology and many others. Our consulting and planning service is based on many years of interdisciplinary experience.

This technical catalogue forms the basis of our discussions with you. Our sales and applications engineers will gladly help you with their expertise. We are looking forward to your enquiries. Our goal is to achieve joint, constructive solutions. Product quality, economic efficiency and high user benefits are the basis of a strategic partnership between NTN-SNR and you – our customer.





Table of contents

1.	Basics of linear guides	4
1.1	Design principles	5
1.2	Ball chain technology	8
1.3	Characteristics	12
1.4	Selection criteria	13
<hr/>		
2.	System technology	14
2.1	Definitions	14
2.2	Used standards	14
2.3	Coordinate system	15
2.4	Static safety	15
2.5	Service life time calculation	16
2.5.1	Influencing factors	17
2.5.2	Active load - equivalence factors	20
2.5.3	Equivalent loads	23
2.5.4	Calculation examples	26
2.6	Preload/rigidity	35
2.6.1	Preload classes	35
2.6.2	Rigidity	37
2.7	Precision	38
2.7.1	Precision classes	38
2.7.2	Interchangeability	40
2.7.3	Error compensation	40
2.8	Drive power	41
2.8.1	Friction	41
2.8.2	Driving resistance	42
2.8.3	Driving force	43
<hr/>		
3.	Installation	45-56
3.1	Arrangement of the installation surfaces	45
3.2	Identification of linear guides	46
3.3	Arrangement of linear guides	48
3.4	Installation position of a linear guide	49
3.5	Installation instructions	50
3.6	Permitted installation tolerances	52
3.7	Fastening torques	56
<hr/>		
4.	Lubrication	57-69
4.1	General information	57
4.2	Lubricants	57
4.2.1	Anti-corrosion oils	58
4.2.2	Lubrication oils	58
4.2.3	Low-viscosity greases	59
4.2.4	Lubrication greases	60
4.3	Lubrication methods	61
4.4	Accessories	63
4.4.1	Grease nipples	63
4.4.2	Lubrication connection	65
4.4.3	Lubrication adapter	65
4.4.4	Grease guns	66
4.4.5	Automated lubricant dispenser	66
4.5	Lubricant volumes	67
4.6	Lubrication intervals	69

5.	Accessories	70-73
5.1	Sealing Options	70
5.1.1	Descriptions	70
5.1.2	Combination options	71
5.1.3	Dimensions	72
5.2	Rail caps	73
5.3	Bellows	74
5.3.1	Dimensions	74
5.3.2	Assembly of bellows	74
5.3.3	Designation	75
5.4	Cover strip	75
5.4.1	Dimensions	75
5.4.2	Mounting tool	75
5.4.3	Designation	75
5.5	Clamping- and Braking Elements	76
5.5.1	Manual clamping elements	76
5.5.1.1	Manual clamping element for standard guides	76
5.5.1.2	Manual clamping element for miniature guides	77
5.5.2	Pneumatic clamping element	78
5.5.2.1	Pneumatic clamping element for standard guides	78
5.5.2.2	Pneumatic clamping element for miniature guides	79
5.5.2.3	Compact pneumatic clamping element for standard guides	79
5.6	Lubrication system LU1	80
5.6.1	Structure	80
5.6.2	Dimension	80
5.6.3	Features	81

6. Corrosion protection / coating 81

7. NTN-SNR linear guides 82-111

7.1	Overview	82
7.2	LGBCH...F	86
7.3	LGBCS...F	88
7.4	LGBCH...B / LGBCX...B	90
7.5	LGBCS...B	92
7.6	LGBXH...F	94
7.7	LGBXS...F	96
7.8	LGBXH...B / LGBXX...B	100
7.9	LGBXS...B	102
7.10	LGMC...B	106
7.11	LGMC...W	104
7.12	LGMX...B	106
7.13	LGMX...W	108
7.14	Standard lengths of NTN-SNR Linear guides	110

8. Type code 112-115

9. Type list 116

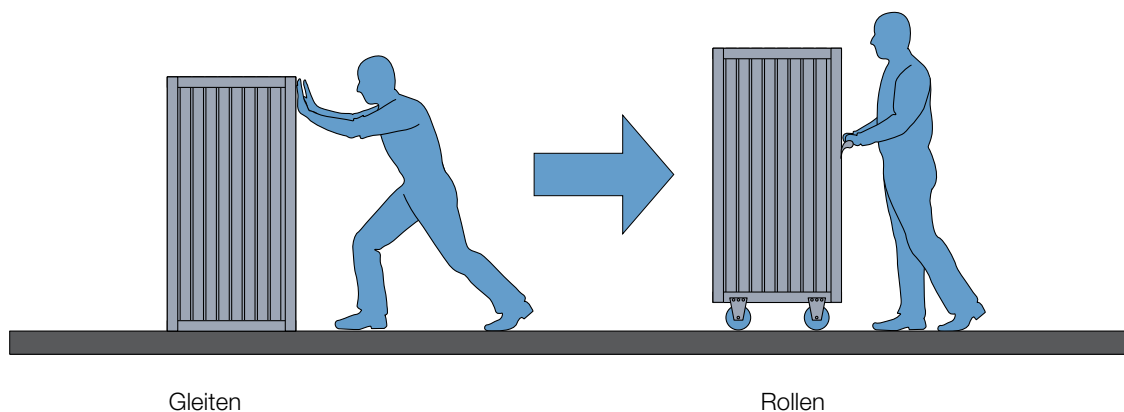
10. Guide to queries 117

11. Index 119

1. Basics of linear guides

Man has moved heavy loads since ancient times using rotation and linear movement or a combination of both. These movements are still found in many machines. The friction bearings initially used have mostly been replaced by roller bearings. Rolling elements in machines were established more than a hundred years ago, while rolling elements for linear movements have only become common in the last few decades.

Figure 1.1 Movement of heavy loads



1.1 Design principles

High surface pressure results when a ball touches a flat surface at one point (Figure 1.2). Grooves in modern linear guides are manufactured with a defined radius to increase the contact area. The ratio of the race way radius to the ball diameter in percent is called osculation. This significantly increases the load capacity, service life time and rigidity of the balls for equal surface pressure.

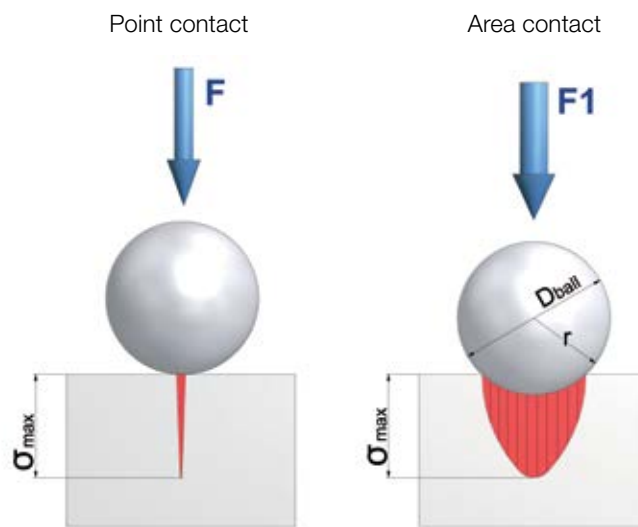


Figure 1.2 NTN-SNR linear guides

σ_{max} maximum surface pressure σ
 D_{ball} Ball diameter
 r Race way radius

There are two basic design principles for linear guides with balls as rolling elements - circular arc grooves and Gothic arc grooves (Figure 1.3).

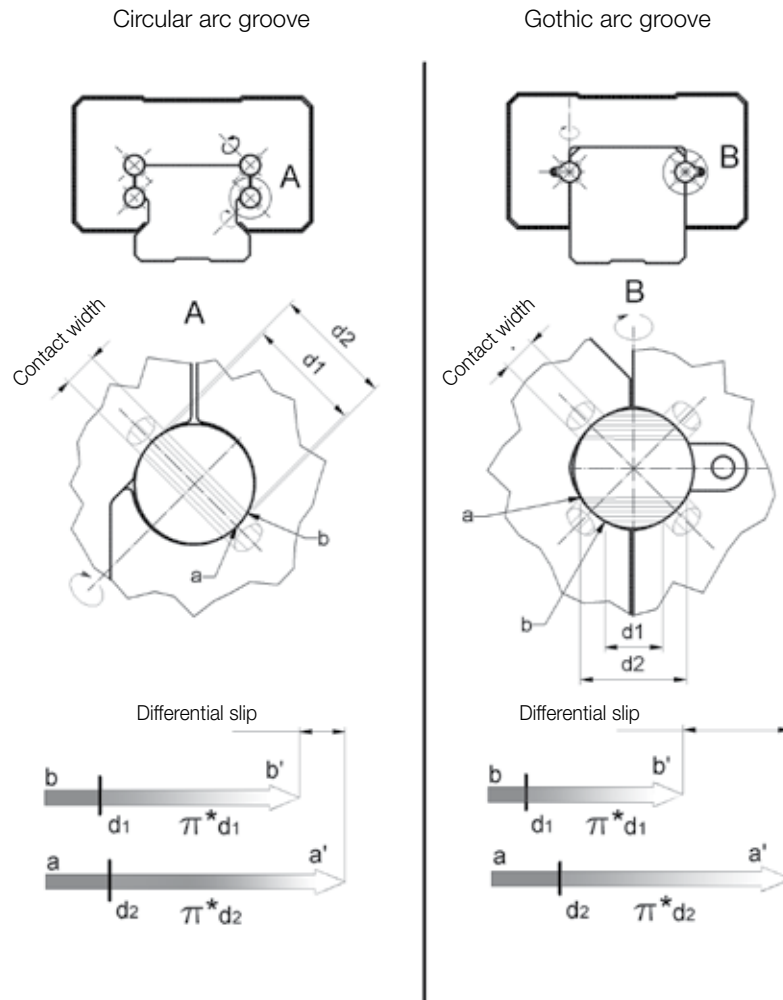
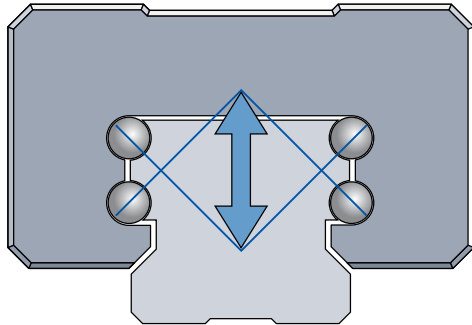


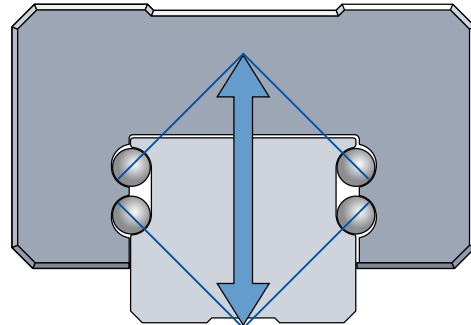
Figure 1.3 Groove geometry

Circular arc grooves have one contact surface on the profile rail and one on the carriage. This creates 2-point contact. The special shape of the Gothic-arc groove creates two contact surfaces on the profile rail and two on the carriage, resulting in 4-point contact with the rolling element. A detailed view of the rolling elements shows that differential slip results from the difference between contact diameters d_1 and d_2 . The differential slip is significantly greater for arrangements with Gothic arc grooves than for circular arc grooves. This leads to a higher friction coefficient, higher driving resistance, higher wear and higher energy consumption. The standard linear guides by NTN-SNR therefore all have circular arc grooves. The geometry of the Gothic arc groove is only used for miniature linear guides, for the compactness of its design.

The race way configuration is another characteristic of linear guides. The following alternatives are used: DF-configuration and DB-configuration of the race ways, corresponding to the terms used for roller bearing systems (Figure 1.4).



Linear guide with DF-configuration



Linear guide with DB-configuration

Figure 1.4 - DF- and DB-configuration

Linear guide systems can be exposed to torque stress resulting from installation faults (Figure 1.5). When the distance between the active points is low, the resulting internal loads is low as well. The NTN-SNR linear guides are therefore produced using the DF-configuration.

Linear guide with DF-configuration

Linear guide with DB-configuration

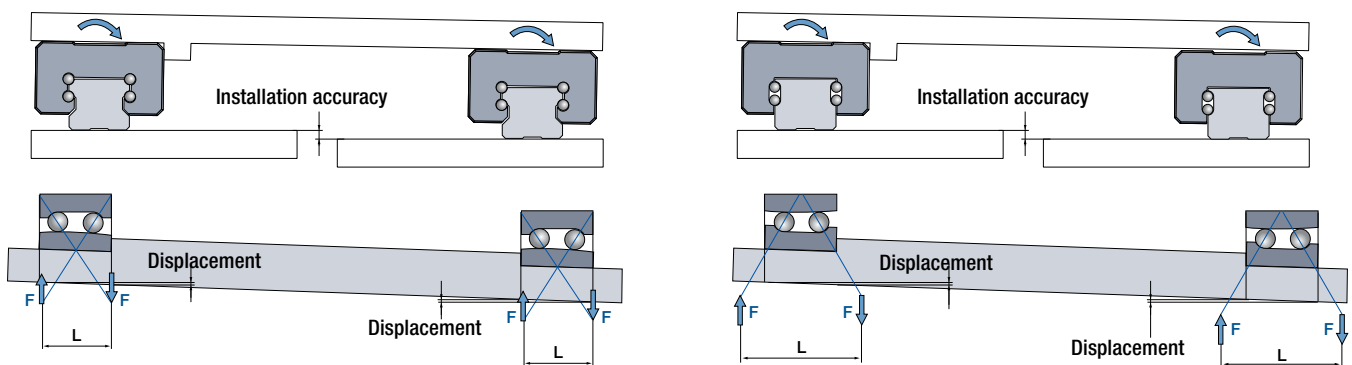


Figure 1.5 Internal forces for DF- and DB-configuration

The most important characteristics of NTN-SNR linear guides are therefore:

- > Wider permitted installation tolerances
- > Very good self-adjustment properties
- > Lower costs for manufacture and preparation of the mounting surfaces

1.2 Ball chain technology

Cages for guiding the rolling elements, which have been used for over 100 years in roller bearings, are also part of the newly developed linear guides. Linear guides with ball chains differ from conventional series in the following characteristics:

- > Higher maximum velocity
- > Less heat generation
- > Less noise generation
- > Very smooth running
- > Optimised lubrication system
- > Even load distribution
- > Longer service life

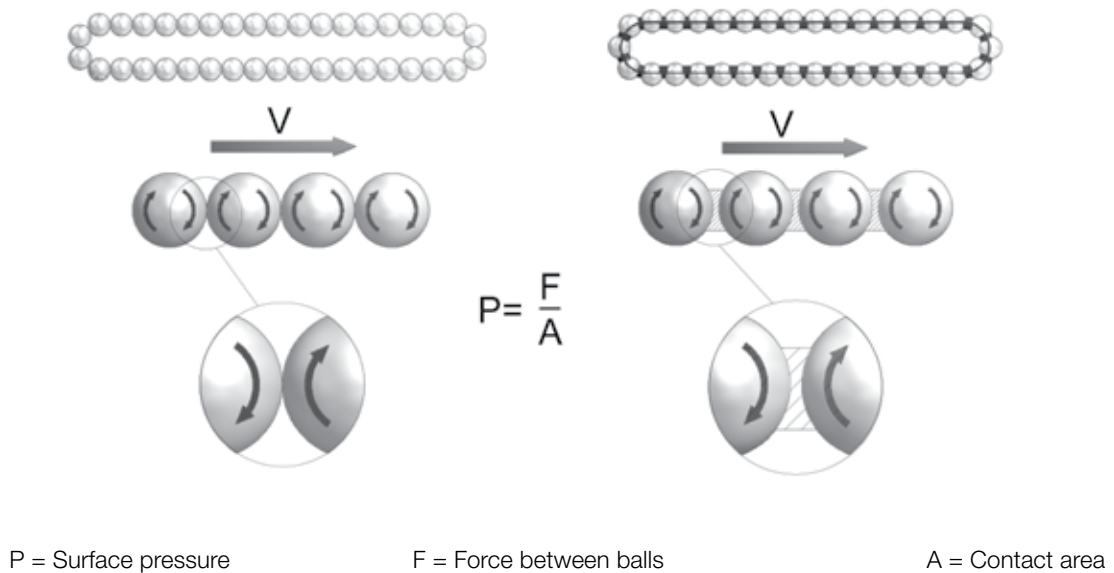


Figure 1.6 Schematic view of the contact surfaces

The rotating balls in conventional linear guides have point contact between each other (Figure 1.6). The rotation speed at the contact point is double that of the speed of the balls. The contact area (A) is so small that the surface pressure (P) tends towards infinity. This leads to heating and wear of the balls and the linear guide system. The chain in linear guides with ball chains has the function of a cage. Contact between the balls is prevented (Figure 1.6). The ball and the chain also have a relatively large contact area (A) that significantly reduces the surface pressure (P). The rotation speeds at the contact surfaces of ball and chain correspond. The ball chain is further used to transport the lubricant and to create a lubrication film on the balls. The design of the carriage allows effective supply with lubricant from the lubricant connection to the circulation areas of the ball chains (Figure 1.7).

Conventional linear guides allow contact between the balls during operation, which may lead to increased lubricant consumption, higher friction, noise and heat. Linear guides with ball chain minimise these effects.

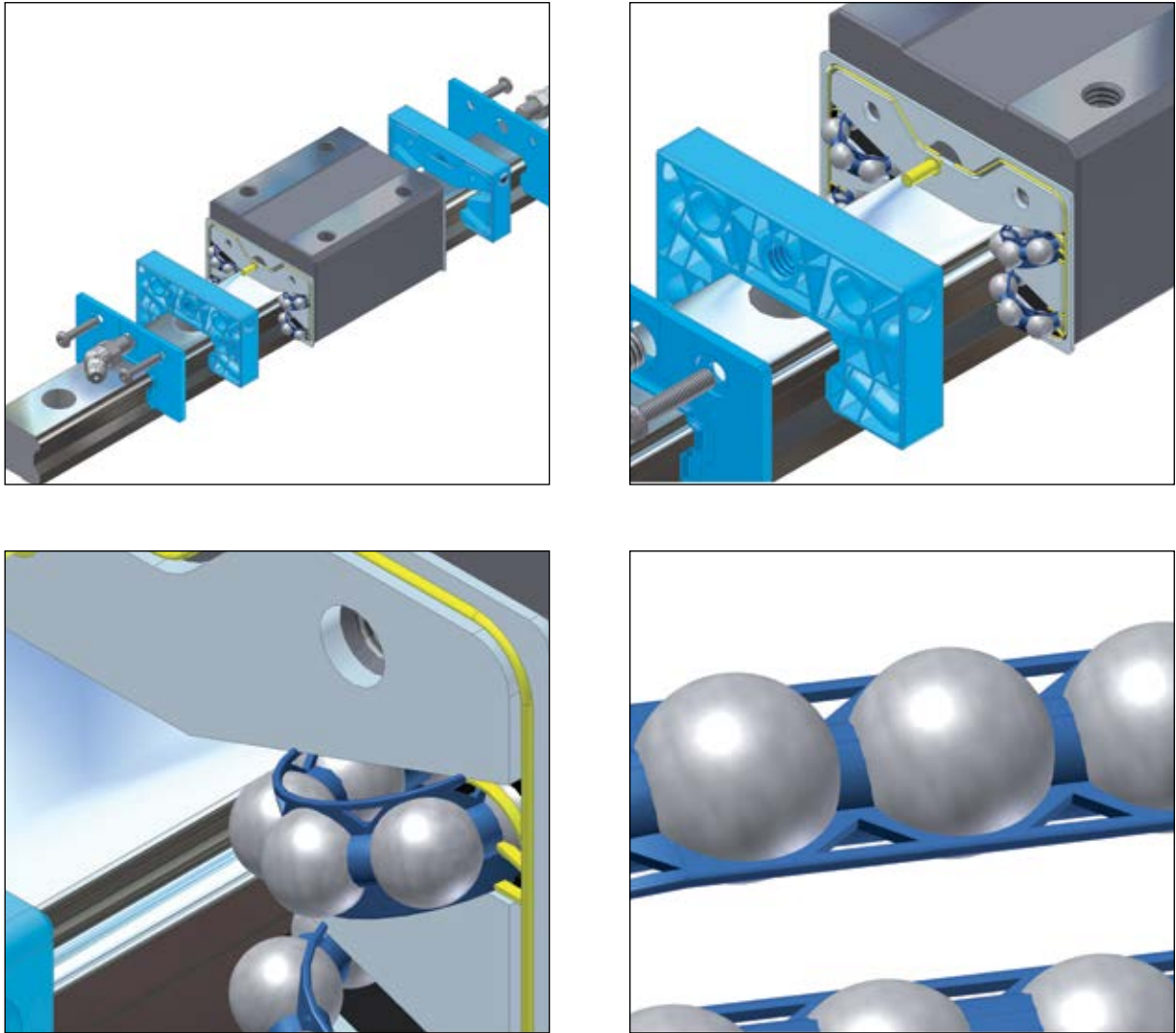


Figure 1.7 Linear guides with ball chains

The noise generation of linear guides is mainly determined by their design. Direct knocking of balls against each other is the main reason for increased noise generation in conventional models. In addition, the contact of the balls with the surfaces of the re-circulating hole affects noise generation (Figure 1.8).

These effects are significantly reduced by the use of ball chains. The patented structure of the ball chain further contains gaps for lubricant depots. The combination of the flexibility of the ball chain and the lubricant acts like a buffer and significantly reduces the noise level (Figure 1.9).

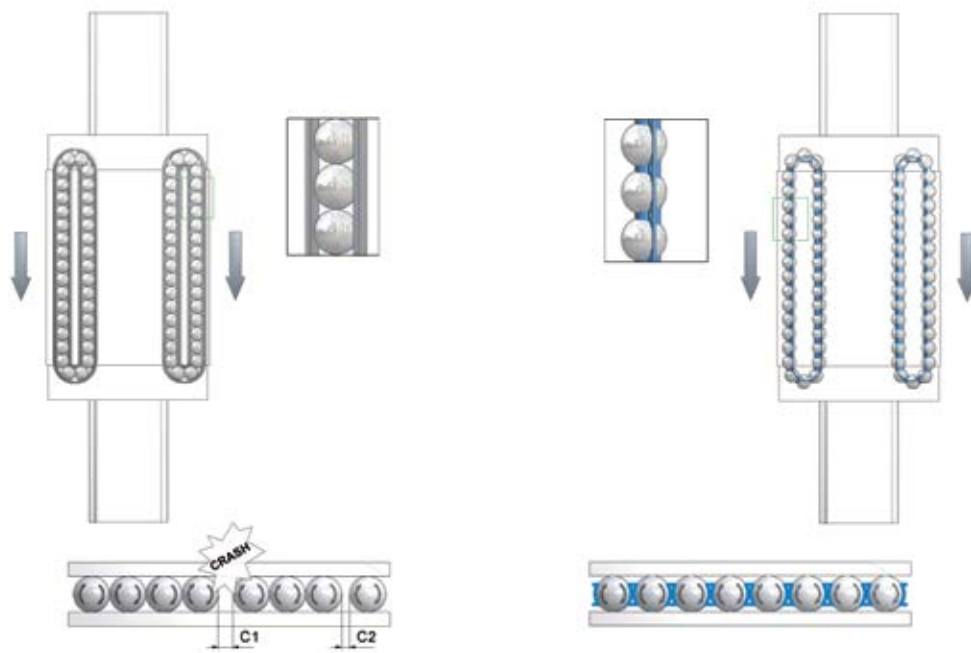


Figure 1.8 Comparison of the designs of linear guides

It is not possible to keep the distance of the balls (C1, C2) constant in conventional linear guides (Figure 1.8). These irregular distances between the balls lead to uneven running behaviour.

At the same time, the balls are continuously supplied with lubricant, which reduces wear of the metal. This significantly extends the service life of the lubricant and the maintenance intervals.

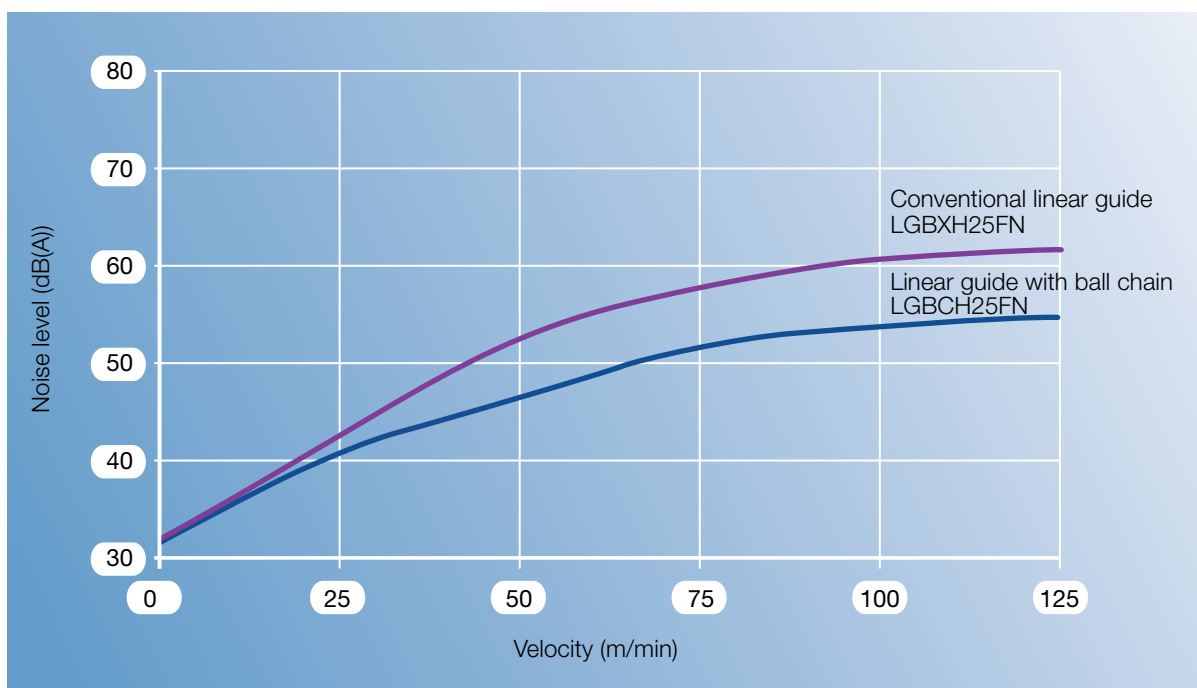


Figure 1.9 Noise generation of linear guides of Design Size 25

The chain in linear guides with ball chain has the function of a cage. It holds the balls at a constant distance from each other and controls their circulation. The structure of the carriages makes it impossible to implement a closed ball chain circulation. At the end of the ball chains, a space of about 1 ball diameter remains. The design of the ends of the NTN-SNR ball chain and the use of a spacer ball compensate for this space (Figure 1.10).

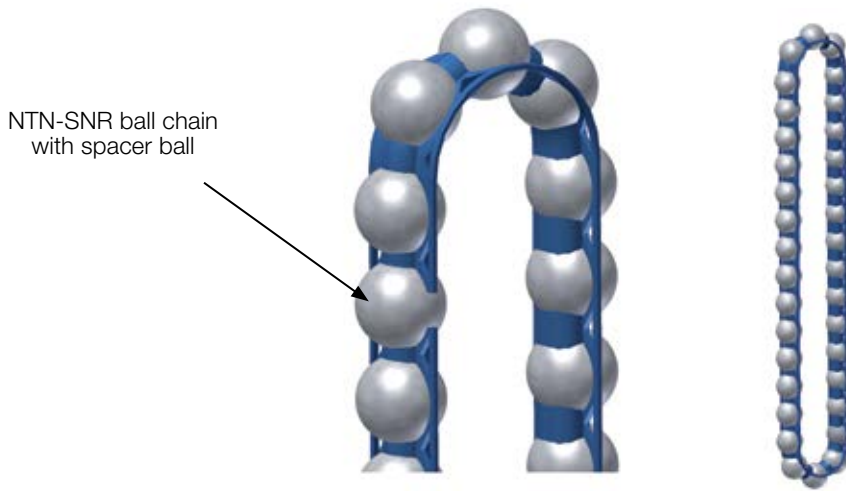


Figure 1.10 NTN-SNR ball chain

This design of the ball chain ends in connection with the spacer ball closes the circulation and makes the movement of the carriage smooth and quiet. (Figure 1.11).

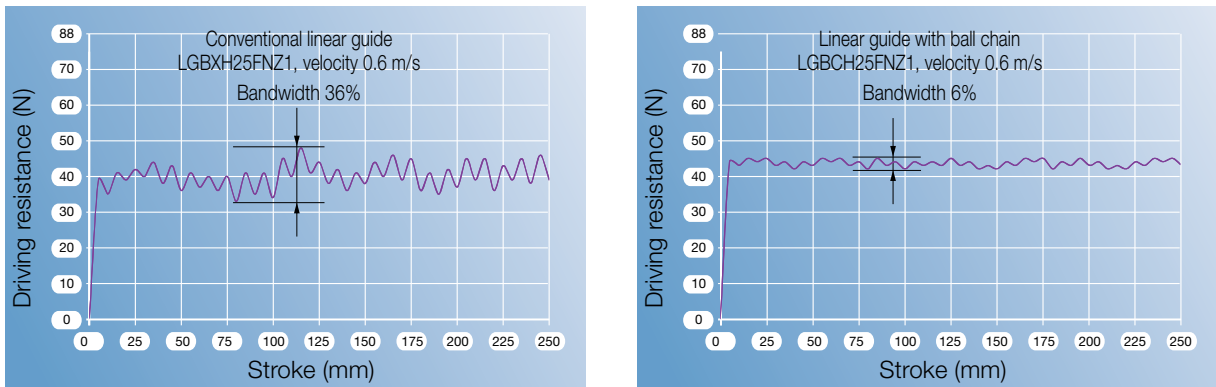


Figure 1.11 Driving resistance

1.3 Characteristics

Linear guides are become more and more indispensable in the modern engineering.

The main features are:

- > High dynamic
- > Low friction
- > High stiffness
- > Optimal running performance
- > Low wear
- > Low-maintenance operation
- > High efficiency
- > Flexible sealing system

NTN-SNR – Linear guides consist of just a few modular designed components.

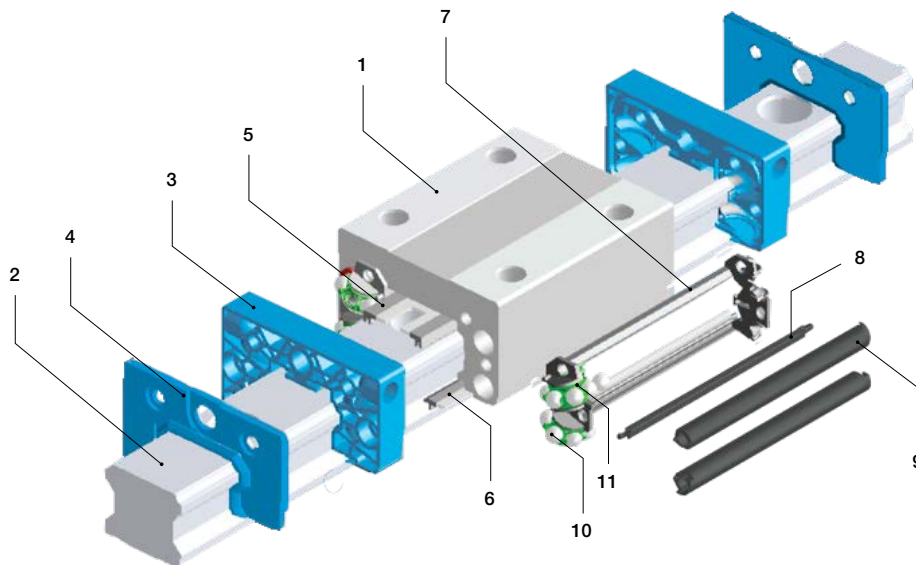
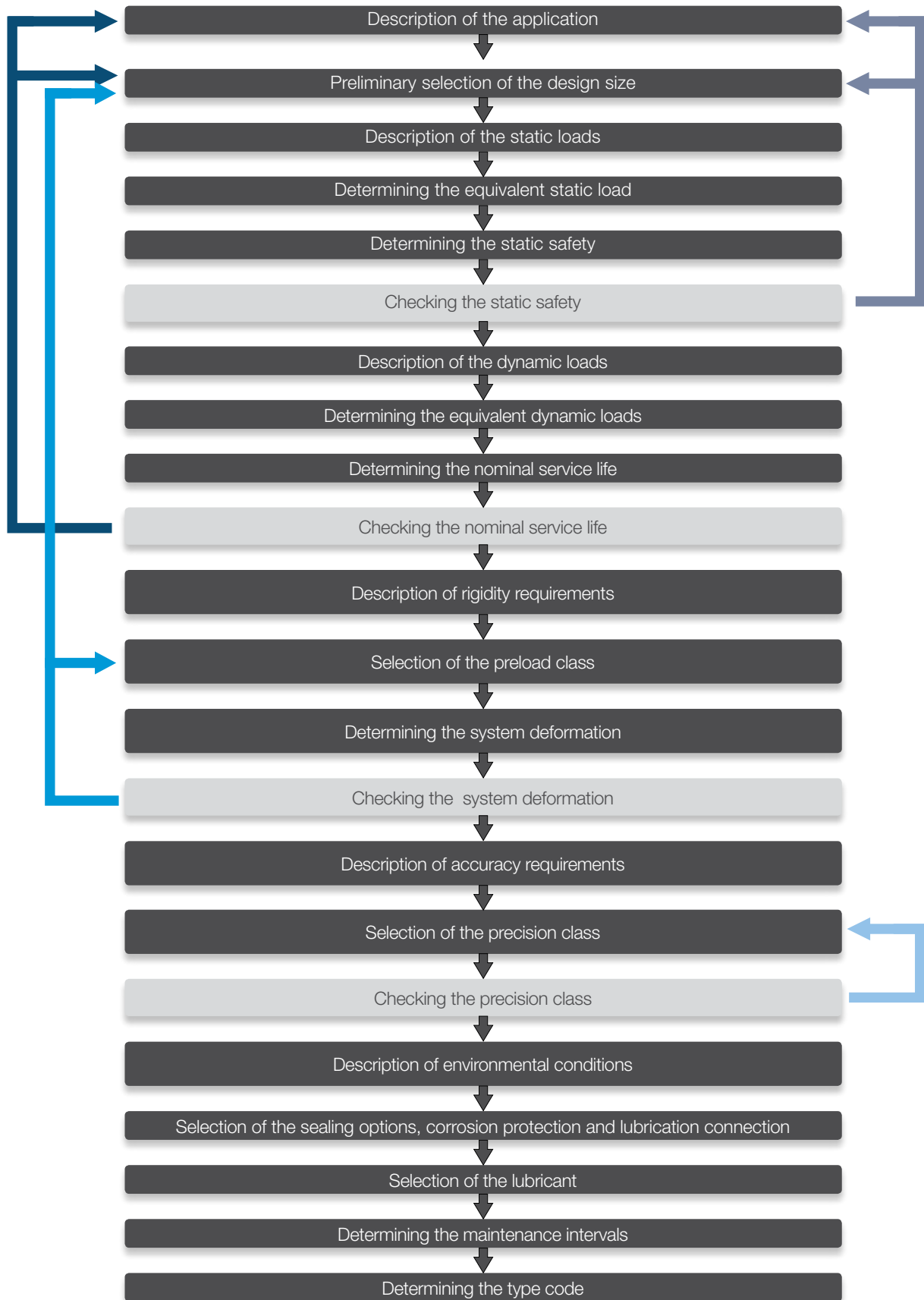


Figure 1.12 Structure

- | | |
|--------------|--------------------------|
| 1 Steel body | 7 Retainer |
| 2 Rail | 8 Retainer center bar |
| 3 End plate | 9 Return tube |
| 4 End seal | 10 Balls |
| 5 Inner seal | 11 Ball chain (optional) |
| 6 Side seal | |

1.3 Selection criteria



2 System technology

2.1 Definitions

Service life time

The service life time L is the running distance that a component can handle before the first signs of material fatigue become apparent on the tracks or the rolling elements.

Nominal service life time L_{10}

The nominal service life time L_{10} is the calculated service life time of a single linear guide system or of a group of equivalent linear guide systems operating under equal conditions that can be reached with a probability of 90%, assuming the use of currently common materials of average manufacturing quality and common operating conditions.

Dynamic load rating C

The dynamic load rating C is the in size and direction constant, radial load that a linear roller bearing can theoretically withstand for a nominal service life of 5×10^4 m travelled distance (according to ISO 14728-1). When the calculation of the dynamic load rating is based on a nominal service life of 10^5 m, the dynamic load rating for a nominal service life of 5×10^4 m is multiplied by the conversion factor 1.26.

Static load rating C_0

The static load rating C_0 is the static, radial load that corresponds to the middle of the highest-stressed contact area between rolling element and race way of a calculated Hertz-type compression. The Hertz-type compression for the linear guide is, according to ISO 14728-1, between 4200 MPa and 4600 MPa and depends on the ball diameter and the osculation.

This load leads to a permanent, total deformation of the rolling element that corresponds to a 0.0001 part of the rolling element diameter (according to ISO 14728-1).

2.2 Standards used

DIN 645-1 Roller bearings - profile rail roller guides – Part 1: Dimensions for Series 1 to 3

DIN 645-2 Roller bearings - profile rail roller guides – Part 2: Dimensions for Series 4

DIN ISO 14728-1 Roller bearings - Linear roller bearings – Part 1: Dynamic load ratings and nominal service life (ISO 14728-1: 2004)

DIN ISO 14728-2 Roller bearings – Linear roller bearings – Part 2: Static load ratings (ISO 14728-2: 2004)

The NTN-SNR linear guides comply with the RoHS Directive (EU Directive 2002/95/EC). NTN-SNR linear guides are not listed in the Machine Directive 2006/42/EC and are therefore not affected by this directive.

2.3 Coordinate system

The linear guides can be stressed by forces or torques. The coordinate system (Figure 2.1) shows the forces acting in the main load directions, the torques as well as the six degrees of freedom.

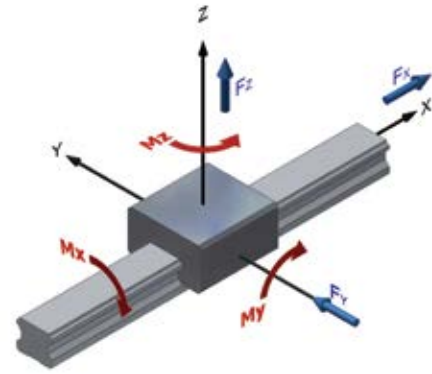


Figure 2.1 Coordinate system

Forces in the main load directions:

- F_x Movement force (X-direction)
- F_y Tangential load (Y-direction)
- F_z Radial load (Z-direction)

Torques:

- M_x Torque in roll direction (rotation around the X-axis)
- M_y Torque in pitch direction (rotation around the Y-axis)
- M_z Torque in yaw direction (rotation around the Z-axis)

Only five degrees of freedom are relevant for the linear guide. The X-direction is the movement direction of the guide, which defines the following accuracy values:

- > Lateral movement (Y-direction)
- > Height movement (Z-direction)
- > Rolling (rotation around the X-axis)
- > Pitching (rotation around the Y-axis)
- > Yawing (rotation around the Z-axis)

2.4 Static safety

The design of linear guides must consider unexpected and unforeseeable forces and/or torques that are caused by vibration or shocks or short start/stop cycles (short strokes) during operation or standstill as well as overhanging loads. A safety factor is particularly important in such cases. The static structural safety factor f_s is intended to prevent unacceptable, permanent deformation of the tracks and the rolling elements. It is the ratio of the static load rating C_0 to the maximum occurring force F_{0max} . The highest amplitude is relevant, even when it occurs only for a very short time.

$$f_s = \frac{C_0}{F_{0max}} * f_H * f_T * f_C \quad [2.1]$$

- f_s static safety factor / static structural safety
- C_0 static load rating [N]
- F_{0max} maximum static load [N]
- f_H Hardness factor
- f_T Temperature factor
- f_C Contact factor

The static safety factor should be bigger than 2 for normal operating conditions. The recommended values listed below should be used for the factor f_s under special operating conditions.

Table 2.1 Values of the static safety factor

Operating conditions	f_s
Normal operating conditions	≈ 2
With less shock exposure and vibration	≈ 2 ... 4
With moderate shock exposure and vibration	3 ... 5
With strong shock exposure and vibration	4 ... 8
With partially unknown load parameters	> 8

We recommend that you contact our NTN-SNR application engineers when the loads are partially unknown or difficult to estimate.

2.5 Service life time calculation

The nominal service life time of a linear guide in m is calculated with the following equation:

Ball guides

$$L_{10} = \left(\frac{C}{F} * \frac{f_H * f_T * f_C}{f_W} \right)^3 * 5 * 10^4 \quad [2.2]$$

Roller guides

$$L_{10} = \left(\frac{C}{F} * \frac{f_H * f_T * f_C}{f_W} \right)^{\frac{10}{3}} * 10^5 \quad [2.3]$$

- L₁₀ Nominal service life time [m]
- C Dynamic load rating [N]
- F Dynamic load [N]
- f_H Hardness factor
- f_T Temperature factor
- f_C Contact factor
- f_W Load factor

The service life time in operating hours can be determined when the stroke length and the stroke frequency remain constant during the service life time.

$$L_h = \frac{L_{10}}{2 \cdot S \cdot n \cdot 60} \quad [2.4]$$

- L₁₀ Nominal service life time [m]
- L_h Service live in hours [h]
- S Stroke length [m]
- n Stroke frequency (double-strokes per minute) [min⁻¹]

It is very difficult to determine the active load for the service life time calculation. The linear guide systems are usually exposed to oscillations or vibrations resulting from the process or drive forces. Shocks can damage machine elements when the load peaks are higher than the maximum additional load. This applies to the dynamic as well as the static state of the total system. The service life time also depends on parameters such as the surface hardness of the rolling elements, the race ways and the temperature of the system. The modified service life time calculation takes the abovementioned conditions into consideration.

2.5.1 Influencing factors

Hardness factor for shaft hardness f_H

The hardness of the rolling elements and the tracks must be between 58 HRC and 60 HRC. This value ensures optimal running properties and the best possible functional properties of the linear guide.

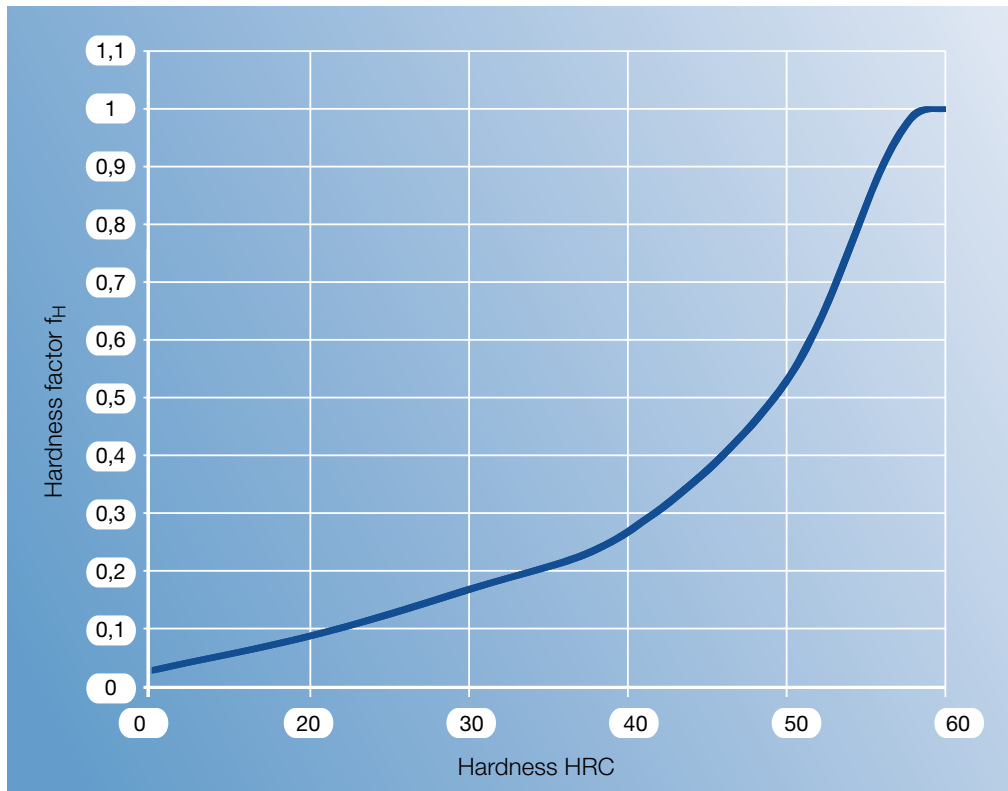


Figure 2.2 Hardness factor f_H

The NTN-SNR linear guides comply with the conditions stipulated above. Therefore, the hardness factor does not need to be considered ($f_H=1$). The hardness corrections (Figure 2.2) are only required when a special version made of special material with a hardness below 58 HRC is used.

Temperature factor f_T

Corrections to the service life time calculations (Figure 2.3) must be made when the environmental temperature of the linear guide exceeds 100°C during operation.

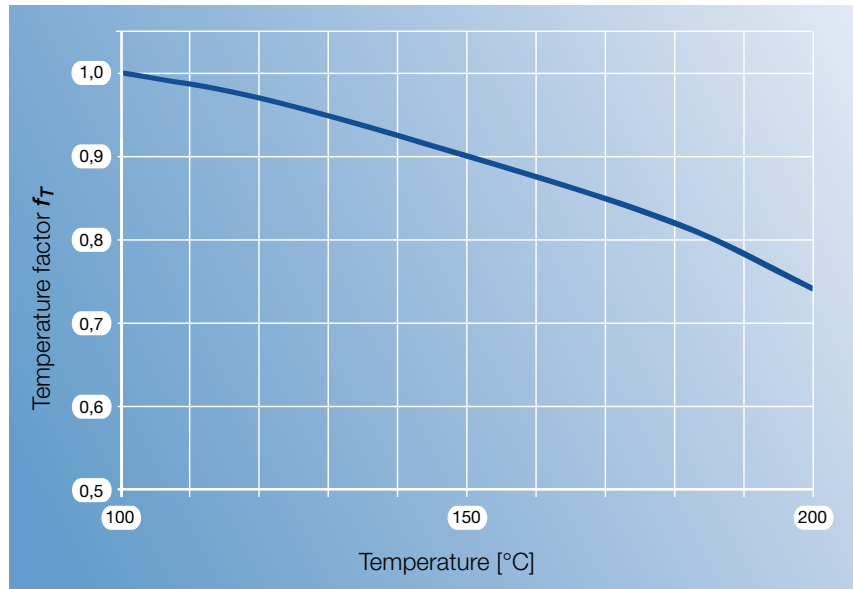


Figure 2.3 Temperature factor f_T

The standard version of the NTN-SNR linear guides can be used up to a maximum temperature of 80°C.

Contact factor f_C

When two or more carriages are installed very close to each other, the running movement is affected by torques, installation accuracy and other factors, so that an even load distribution is hard to achieve. Under such conditions, an appropriate contact factor (Table 2.2) must be taken into account.

Table 2.2 Contact factor

Number of closely spaced carriages	f_C
1	1,00
2	0,81
3	0,72
4	0,66
5	0,61

Load factor f_w

Vibrations and shocks that may occur during operation, for example as a result of high speeds, repeated starting and stopping, process forces or sudden loads, can have a significant effect on the total calculation. It is in some cases very difficult to determine their effects. Empirically determined load factors (Table 2.3) must be used when the actual loads on the linear guide cannot be measured or can be significantly higher than calculated.

Table 2.3 Load factor

Operating conditions, velocity v	f_w
Normal operating conditions without vibrations/shocks $v \leq 0,25$ m/s	1,0... 1,5
Normal operating conditions with weak vibrations/shocks $0,25 < v \leq 1,0$ m/s	1,5... 2,0
Normal operating conditions with strong vibrations/shocks $v > 1,0$ m/s	2,0... 3,5

2.5.2 Active load - equivalence factors

One-axis application

Linear guides are often used with one carriage or several carriage with small distance between them when the installation space is tight. The service life time of the linear guide can be shortened in such cases, due to the increased wear at the carriage ends. Under such operating conditions, the torques must be multiplied by appropriate equivalence factors (Table 2.4 and Table 2.5).

The equivalent load is determined as follows:

$$F_E = k \cdot M \quad [2.7]$$

- F_E Equivalent load per guide [N]
- k Equivalence factors (Table 2.4 and Table 2.5)
- M corresponds to the active torque [Nm]

Table 2.4 Equivalence factors (Type LGB..)

Series	Equivalence factor [m ⁻¹]				
	k1x	k1y	k2y	k1z	k2z
LGB_15_S	143,5	309,4	38,1	309,4	38,1
LGB_15_N	145,3	165,8	28,8	165,8	28,8
LGB_15_L	144,9	140,6	26,0	140,6	26,0
LGB_15_E	144,5	139,4	21,9	139,4	21,9
LGB_20_S	107,6	241,4	32,5	241,4	32,5
LGB_20_N	107,1	138,2	24,5	138,2	24,5
LGB_20_L	106,7	109,6	21,3	109,6	21,3
LGB_20_E	106,9	87,8	18,4	87,8	18,4
LGB_25_S	92,8	207,2	29,2	207,2	29,2
LGB_25_N	93,4	116,6	21,6	116,6	21,6
LGB_25_L	93,1	92,9	18,7	92,9	18,7
LGB_25_E	93,1	77,2	16,5	77,2	16,5
LGB_30_S	77,3	179,8	24,6	179,8	24,6
LGB_30_N	77,2	99,1	18,1	99,1	18,1
LGB_30_L	77,2	86,0	16,6	86,0	16,6
LGB_30_E	77,2	64,8	13,7	64,8	13,7
LGB_35_S	63,3	150,7	21,1	150,7	21,1
LGB_35_N	63,2	83,4	15,4	83,4	15,4
LGB_35_L	63,3	72,5	14,2	72,5	14,2
LGB_35_E	63,2	54,8	11,7	54,8	11,7
LGB_45_N	47,3	71,4	13,4	71,4	13,4
LGB_45_L	47,3	61,0	12,1	61,0	12,1
LGB_45_E	47,3	48,3	10,3	48,3	10,3
LGB_55_N	40,4	57,9	11,3	57,9	11,3
LGB_55_L	40,4	43,6	9,3	43,6	9,3
LGB_55_E	40,4	39,2	8,6	39,2	8,6

- k1x Equivalence factor for 1 carriage in Mx-direction
- k1y Equivalence factor for 1 carriage in My-direction
- k2y Equivalence factor for 2 carriages with direct contact in My-direction
- k1z Equivalence factor for 1 carriage in Mz-direction
- k2z Equivalence factor for 2 carriages with direct contact in Mz-direction

Table 2.5 Equivalence factors (Type LGM..)

Series	Equivalence factor [m ⁻¹]				
	k1x	k1y	k2y	k1z	k2z
LGM_07BN	300,8	488,7	64,2	488,7	56,1
LGM_09BN	209,1	255,6	53,0	255,6	53,0
LGM_09BL	220,7	194,7	42,5	194,7	42,5
LGM_09WN	106,8	236,4	43,2	236,4	43,2
LGM_09WL	105,1	153,9	34,5	153,9	34,5
LGM_12BN	152,2	291,7	47,0	291,7	47,0
LGM_12BL	154,7	187,9	36,4	187,9	36,4
LGM_12WN	80,5	204,2	37,9	204,2	37,9
LGM_12WL	80,2	144,1	29,8	144,1	29,8
LGM_15BN	142,8	219,6	38,2	219,6	38,2
LGM_15BL	143,2	145,8	28,8	145,8	28,8
LGM_15WN	48,9	167,8	30,5	167,8	30,5
LGM_15WL	48,0	110,3	23,7	110,3	23,7

- k1x Equivalence factor for 1 carriage in Mx-direction
- k1y Equivalence factor for 1 carriage in My-direction
- k2y Equivalence factor for 2 carriages with direct contact in My-direction
- k1z Equivalence factor for 1 carriage in Mz-direction
- k2z Equivalence factor for 2 carriages with direct contact in Mz-direction

Two-axis application

The following requirements and operating conditions (Figure 2.4) must be defined for calculating the service life time:

- > Stroke length s [mm]
- > Velocity diagram (Figure 2.5)
- > Velocity v [m/s]
- > Acceleration/deceleration a [m/s²]
- > Movement cycles, number of double-strokes per minute n [min⁻¹]
- > Arrangement of the linear guide (number of rails and runner blocks l_0, l_1 , [mm])
- > Installation position (horizontal, vertical, diagonal, wall installation, tilted by 180°)
- > Mass m [kg]
- > Direction of the outer forces
- > Positions of the centres of gravity l_2, l_3, l_4 , [mm]
- > Position of the drive l_5, l_6 , [mm]
- > Required service life L [km] or [h]

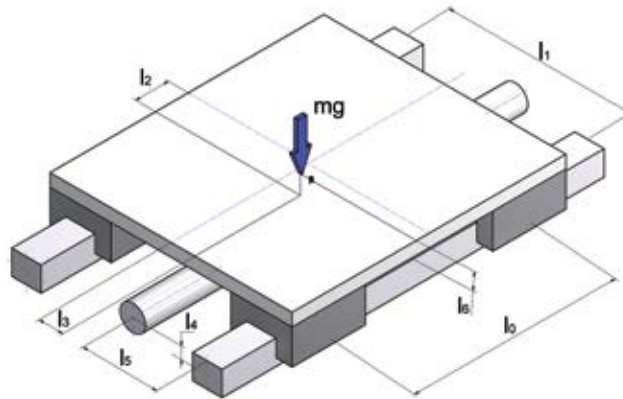


Figure 2.4 Definition of the conditions

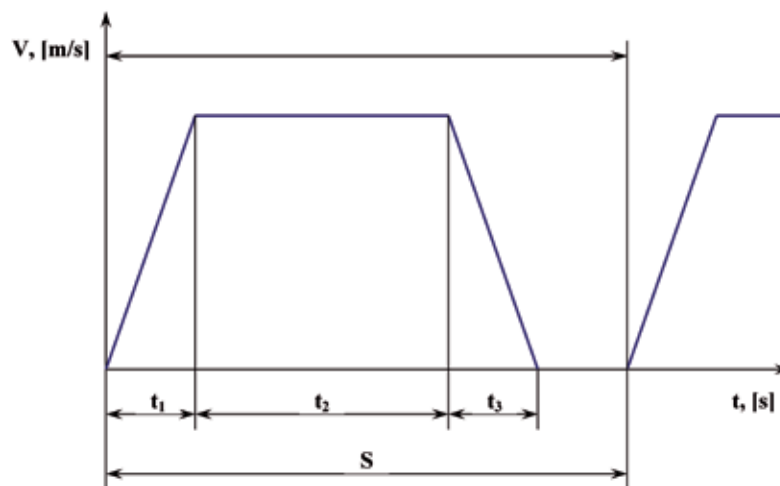


Figure 2.5 Velocity/time diagram

2.5.3 Equivalent loads

The (radial and tangential) loads as well as torque loads may act on the profile rail guide from different directions at the same time (Figure 2.6). In this case, the service life is calculated by using the equivalent load, which includes the radial, tangential and other loads.

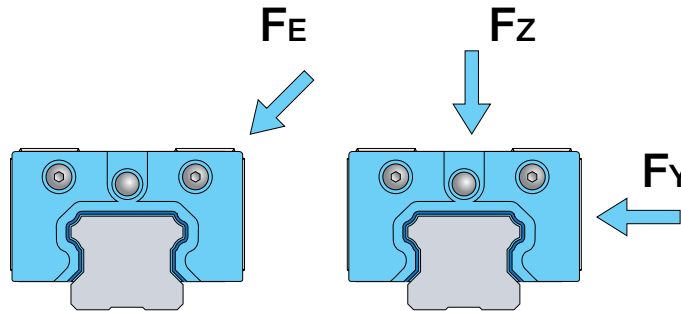


Figure 2.6 Equivalent load F_E

$$F_E = |F_Y| + |F_Z| \quad [2.8]$$

F_E - Equivalent load [N]

F_Y - Tangential load [N]

F_Z - Radial load [N]

The calculation of the equivalent load F_E considers that the NTN-SNR linear guides have the same load-rating capacity in all main directions.

Dynamic equivalent load

It is common that different, varying process forces affect the total system during operation. The guides are, for example, exposed to changing loads during upward and downward movements for picking and placing applications. Where such varying loads occur, they must be considered in the service life time calculations. The calculation of the dynamically equivalent load determines the load on a carriage for each individual movement phase $n_1, n_2 \dots n_n$ (see Chapter 2.4.2) and is summarised in a resulting load for the total cycle. The load change can take place in various ways:

- > Stepwise (Figure 2.7)
- > Linear (Figure 2.8)
- > Sinusoidal (Figure 2.9 and 2.10)

Stepwise load change

$$F_m = \sqrt[3]{\frac{1}{S} (F_1^3 \cdot S_1 + F_2^3 \cdot S_2 + \dots + F_n^3 \cdot S_n)} \quad [2-9]$$

- F_m Dynamic equivalent load [N]
- F_n Load change [N]
- S Total travel [mm]
- S_n Travel during load change F_n [mm]

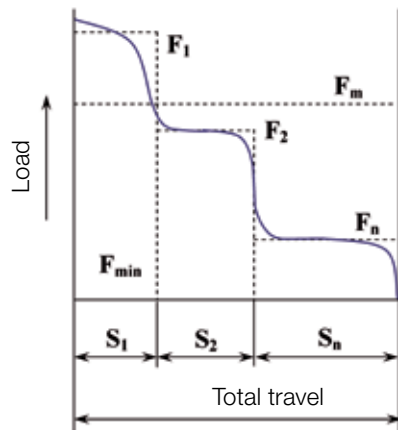


Figure 2.7 Stepwise load change

Linear load change

$$F_m \cong \frac{1}{3} (F_{MIN} + 2 \cdot F_{MAX}) \quad [2-10]$$

- F_{MIN} Minimum load [N]
- F_{MAX} Maximum load [N]

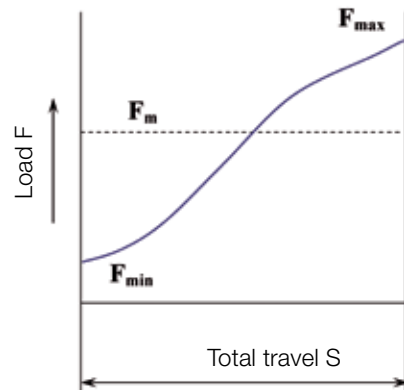


Figure 2.8 Linear load change

Sinusoidal load change

$$F_m \cong 0,65 * F_{MAX} \quad [2.11]$$

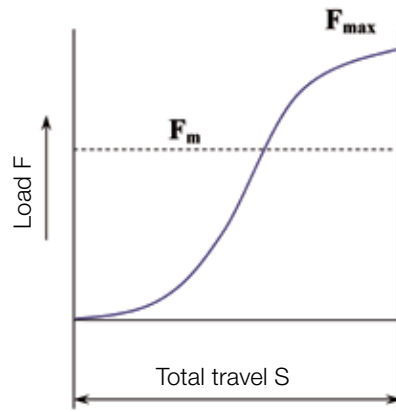


Figure 2.9 Sinusoidal load change (a)

Sinusoidal load change

$$F_m \cong 0,75 * F_{MAX} \quad 2.12]$$

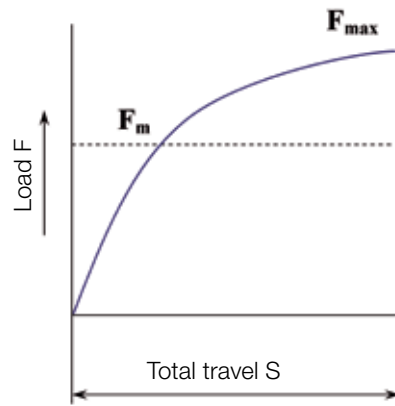


Figure 2.10 Sinusoidal load change (b)

2.5.4 Calculation examples

Example 1

Horizontal installation position with overhanging load
 One carriage
 LGBCH20FN
 Gravity constant $g=9.8 \text{ m/s}^2$
 Mass $m=10 \text{ kg}$
 $l_2=200 \text{ mm}$, $l_3=100 \text{ mm}$
 $C=17,71 \text{ kN}$
 $C_0=30,50 \text{ kN}$
 Normal operating conditions without vibrations $f_w = 1,5$

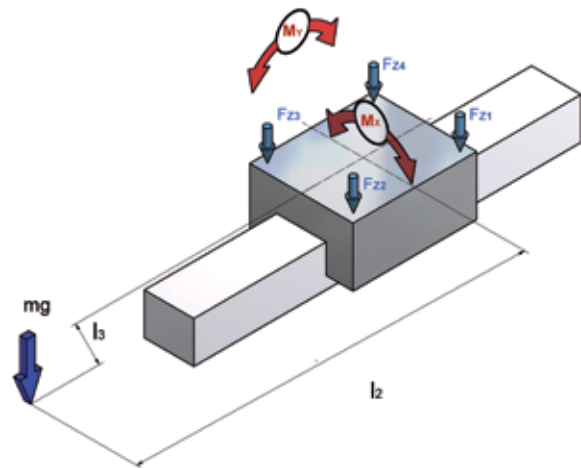


Figure 2.11 Calculation example 1

Calculation:

The equivalent load for the linear guide is calculated, taking the formula [2.7] and the equivalence factors (Table 2.5) into account.

$$Fz_1 = mg - k_x * mg * l_3 - k_y * mg * l_2 = 10 * 9,8 - 107 * 10 * 9,8 * 0,1 - 138 * 10 * 9,8 * 0,2 = -3.655,4 \text{ N}$$

$$Fz_2 = mg - k_x * mg * l_3 + k_y * mg * l_2 = 10 * 9,8 - 107 * 10 * 9,8 * 0,1 + 138 * 10 * 9,8 * 0,2 = 1.754,2 \text{ N}$$

$$Fz_3 = mg + k_x * mg * l_3 + k_y * mg * l_2 = 10 * 9,8 + 107 * 10 * 9,8 * 0,1 + 138 * 10 * 9,8 * 0,2 = 3.851,4 \text{ N}$$

$$Fz_4 = mg + k_x * mg * l_3 - k_y * mg * l_2 = 10 * 9,8 + 107 * 10 * 9,8 * 0,1 - 138 * 10 * 9,8 * 0,2 = -1.558,2 \text{ N}$$

The static safety factor for the maximum load of 3,547.6 N is calculated according to [2.1].

$$f_s = \frac{C_0}{F_{0MAX}} = \frac{30.500}{3.851,4} = 7,9$$

The nominal service life time for the maximum load 3,547.6 N is calculated according to [2.5].

$$L_{10} = \left(\frac{C}{F} * \frac{f_H * f_T * f_C}{f_w} \right)^3 * 5 * 10^4 = \left(\frac{17.710}{3.851,4} * \frac{1}{1,5} \right)^3 * 5 * 10^4 = 1.440.443 \text{ m} = 14.404 \text{ km}$$

Example 2

Horizontal installation position with overhanging load and 2 rails arranged in parallel. Two carriages per rail, arrangement with mobile table

LGBCH30FN

Gravity constant $g=9.8 \text{ m/s}^2$

Mass $m=400 \text{ kg}$

$l_0=600 \text{ mm}$, $l_1=450 \text{ mm}$, $l_2=400 \text{ mm}$, $l_3=350 \text{ mm}$

$C=36,71 \text{ kN}$

$C_0=54,570 \text{ kN}$

Normal operating conditions without vibrations $f_w=1,5$

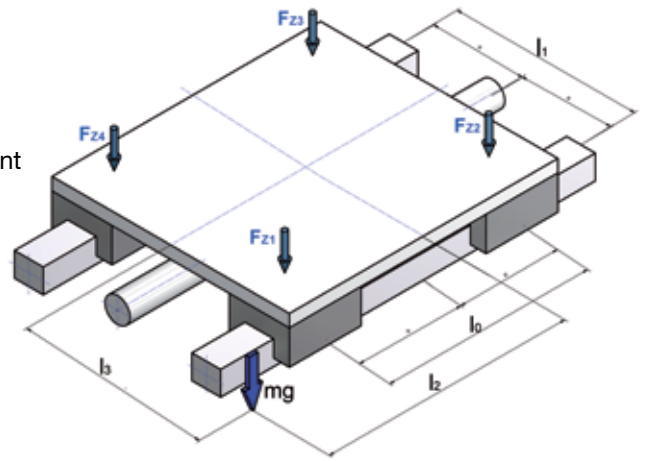


Figure 2.12 Calculation example 2

Calculation:

a) The active radial load per carriage at constant velocity is calculated as follows:

$$F_{Z1} = \frac{mg}{4} + \frac{mg \cdot l_2}{2 \cdot l_0} + \frac{mg \cdot l_3}{2 \cdot l_1} = \frac{400 \cdot 9,8}{4} + \frac{400 \cdot 9,8 \cdot 400}{2 \cdot 600} + \frac{400 \cdot 9,8 \cdot 350}{2 \cdot 450} = 3.811,11 \text{ N}$$

$$F_{Z2} = \frac{mg}{4} - \frac{mg \cdot l_2}{2 \cdot l_0} + \frac{mg \cdot l_3}{2 \cdot l_1} = \frac{400 \cdot 9,8}{4} - \frac{400 \cdot 9,8 \cdot 400}{2 \cdot 600} + \frac{400 \cdot 9,8 \cdot 350}{2 \cdot 450} = 1.197,77 \text{ N}$$

$$F_{Z3} = \frac{mg}{4} - \frac{mg \cdot l_2}{2 \cdot l_0} - \frac{mg \cdot l_3}{2 \cdot l_1} = \frac{400 \cdot 9,8}{4} - \frac{400 \cdot 9,8 \cdot 400}{2 \cdot 600} - \frac{400 \cdot 9,8 \cdot 350}{2 \cdot 450} = -1.851,11 \text{ N}$$

$$F_{Z4} = \frac{mg}{4} + \frac{mg \cdot l_2}{2 \cdot l_0} - \frac{mg \cdot l_3}{2 \cdot l_1} = \frac{400 \cdot 9,8}{4} + \frac{400 \cdot 9,8 \cdot 400}{2 \cdot 600} - \frac{400 \cdot 9,8 \cdot 350}{2 \cdot 450} = 762,23 \text{ N}$$

b) The statistical safety factor is calculated for carriage 1 according to [2.1] for a maximum load of 3,811.11 N.

$$f_s = \frac{C_0}{F_{0MAX}} = \frac{54.570}{3.811,11} = 14,3$$

c) The service life time of the four runner blocks is calculated according to [2.5]

$$L_1 = \left(\frac{C}{F_{Z1}} * \frac{f_H * f_T * f_C}{f_w} \right)^3 * 5 * 10^4 = \left(\frac{36.710}{3.811,11} * \frac{1}{1,5} \right)^3 * 5 * 10^4 = 13.240.211 \text{ m} = 13.240 \text{ km}$$

$$L_2 = \left(\frac{C}{F_{Z2}} * \frac{f_H * f_T * f_C}{f_w} \right)^3 * 5 * 10^4 = \left(\frac{36.710}{1.197,77} * \frac{1}{1,5} \right)^3 * 5 * 10^4 = 426.509.871 \text{ m} = 426.510 \text{ km}$$

$$L_3 = \left(\frac{C}{F_{Z3}} * \frac{f_H * f_T * f_C}{f_w} \right)^3 * 5 * 10^4 = \left(\frac{36.710}{1.851,11} * \frac{1}{1,5} \right)^3 * 5 * 10^4 = 115.545.411 \text{ m} = 115.545 \text{ km}$$

$$L_4 = \left(\frac{C}{F_{Z4}} * \frac{f_H * f_T * f_C}{f_w} \right)^3 * 5 * 10^4 = \left(\frac{36.710}{762,23} * \frac{1}{1,5} \right)^3 * 5 * 10^4 = 1.654.974.350 \text{ m} = 1.654.974 \text{ km}$$

The nominal service life time for the most highly stressed carriage 1 corresponds to the service life time of the total system for the application described above and is 13,240 km.

Example 3

Vertical installation position (e.g. transport lift, Z-axis of a lifting device) with inertia forces, 2 rails arranged in parallel, 2 carriages per rail, LGBCH20FN

- v=1 m/s
- a=0,5 m/s²
- s₁=1000 mm
- s₂=2000 mm
- s₃=1000 mm
- Mass m=100 kg

- Gravity constant g=9.8 m/s²
- l₀=300 mm, l₁=500 mm, l₅=250 mm, l₆=280 mm
- C=17,71 kN
- C₀=30,50 kN
- f_w=2,0 (T able 2.3)

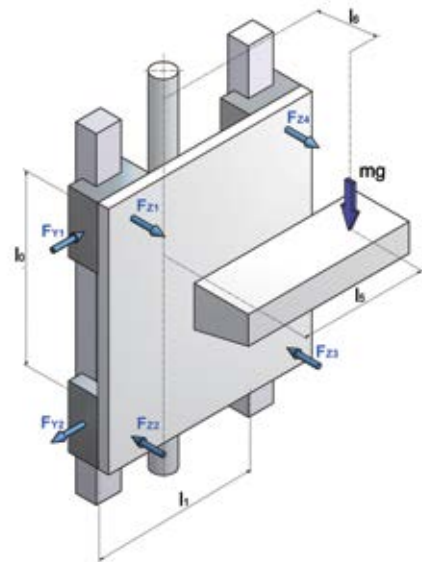


Figure 2.13 Calculation example 3

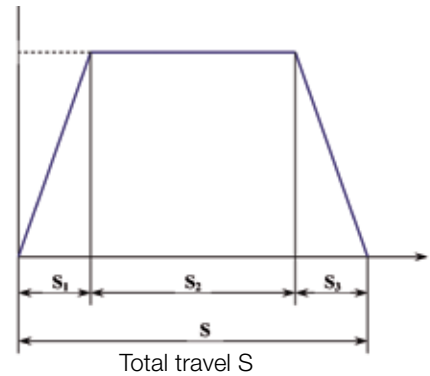


Figure 2.14 Velocity/distance diagram

Calculation:

a) The active loads are calculated per carriage

During the acceleration phase

Radial loads

$$F_{BeschZ1} = \frac{m(g+a) \cdot l_6}{2 \cdot l_0} = \frac{100 \cdot (9,8 + 0,5) \cdot 280}{2 \cdot 300} = 480,67 \text{ N}$$

$$F_{BeschZ2} = -\frac{m(g+a) \cdot l_6}{2 \cdot l_0} = -\frac{100 \cdot (9,8 + 0,5) \cdot 280}{2 \cdot 300} = -480,67 \text{ N}$$

$$F_{BeschZ3} = -\frac{m(g+a) \cdot l_6}{2 \cdot l_0} = -\frac{100 \cdot (9,8 + 0,5) \cdot 280}{2 \cdot 300} = -480,67 \text{ N}$$

$$F_{BeschZ4} = \frac{m(g+a) \cdot l_6}{2 \cdot l_0} = \frac{100 \cdot (9,8 + 0,5) \cdot 280}{2 \cdot 300} = 480,67 \text{ N}$$

Tangential loads

$$F_{BeschY1} = \frac{m(g+a) * l_5}{2 * l_0} = \frac{100 * (9,8 + 0,5) * 250}{2 * 300} = 429,17 \text{ N}$$

$$F_{BeschY2} = -\frac{m(g+a) * l_5}{2 * l_0} = -\frac{100 * (9,8 + 0,5) * 250}{2 * 300} = -429,17 \text{ N}$$

$$F_{BeschY3} = -\frac{m(g+a) * l_5}{2 * l_0} = -\frac{100 * (9,8 + 0,5) * 250}{2 * 300} = -429,17 \text{ N}$$

$$F_{BeschY4} = \frac{m(g+a) * l_5}{2 * l_0} = \frac{100 * (9,8 + 0,5) * 250}{2 * 300} = 429,17 \text{ N}$$

At constant velocity

Radial loads

$$F_{KonstZ1} = \frac{mg * l_6}{2 * l_0} = \frac{100 * 9,8 * 280}{2 * 300} = 457,33 \text{ N}$$

$$F_{KonstZ2} = -\frac{mg * l_6}{2 * l_0} = -\frac{100 * 9,8 * 280}{2 * 300} = -457,33 \text{ N}$$

$$F_{KonstZ3} = -\frac{mg * l_6}{2 * l_0} = -\frac{100 * 9,8 * 280}{2 * 300} = -457,33 \text{ N}$$

$$F_{KonstZ4} = \frac{mg * l_6}{2 * l_0} = \frac{100 * 9,8 * 280}{2 * 300} = 457,33 \text{ N}$$

Tangential loads

$$F_{KonstY1} = \frac{mg * l_5}{2 * l_0} = \frac{100 * 9,8 * 250}{2 * 300} = 408,33 \text{ N}$$

$$F_{KonstY2} = -\frac{mg * l_5}{2 * l_0} = -\frac{100 * 9,8 * 250}{2 * 300} = -408,33 \text{ N}$$

$$F_{KonstY3} = -\frac{mg * l_5}{2 * l_0} = -\frac{100 * 9,8 * 250}{2 * 300} = -408,33 \text{ N}$$

$$F_{KonstY4} = \frac{mg * l_5}{2 * l_0} = \frac{100 * 9,8 * 250}{2 * 300} = 408,33 \text{ N}$$

During the deceleration phase

Radial loads

$$F_{Verz1} = \frac{m(g - a) * l_6}{2 * l_0} = \frac{100 * (9,8 - 0,5) * 280}{2 * 300} = 434 \text{ N}$$

$$F_{Verz2} = -\frac{m(g - a) * l_6}{2 * l_0} = -\frac{100 * (9,8 - 0,5) * 280}{2 * 300} = -434 \text{ N}$$

$$F_{Verz3} = -\frac{m(g - a) * l_6}{2 * l_0} = -\frac{100 * (9,8 - 0,5) * 280}{2 * 300} = -434 \text{ N}$$

$$F_{Verz4} = \frac{m(g - a) * l_6}{2 * l_0} = \frac{100 * (9,8 - 0,5) * 280}{2 * 300} = 434 \text{ N}$$

Tangential loads

$$F_{VerzY1} = \frac{m(g - a) * l_5}{2 * l_0} = \frac{100 * (9,8 - 0,5) * 250}{2 * 300} = 387,50 \text{ N}$$

$$F_{VerzY2} = -\frac{m(g - a) * l_5}{2 * l_0} = -\frac{100 * (9,8 - 0,5) * 250}{2 * 300} = -387,50 \text{ N}$$

$$F_{VerzY3} = -\frac{m(g - a) * l_5}{2 * l_0} = -\frac{100 * (9,8 - 0,5) * 250}{2 * 300} = -387,50 \text{ N}$$

$$F_{VerzY4} = \frac{m(g - a) * l_5}{2 * l_0} = \frac{100 * (9,8 - 0,5) * 250}{2 * 300} = 387,50 \text{ N}$$

b) The combined radial and tangential loads are calculated per carriage according to [2.8].

During the acceleration phase

$$F_{BeschE1} = |F_{BeschZ1}| + |F_{BeschY1}| = 909,84 \text{ N}$$

$$F_{BeschE2} = |F_{BeschZ2}| + |F_{BeschY2}| = 909,84 \text{ N}$$

$$F_{BeschE3} = |F_{BeschZ3}| + |F_{BeschY3}| = 909,84 \text{ N}$$

$$F_{BeschE4} = |F_{BeschZ4}| + |F_{BeschY4}| = 909,84 \text{ N}$$

At constant velocity

$$F_{KonstE1} = |F_{KonstZ1}| + |F_{KonstY1}| = 865,67 \text{ N}$$

$$F_{KonstE2} = |F_{KonstZ2}| + |F_{KonstY2}| = 865,67 \text{ N}$$

$$F_{KonstE3} = |F_{KonstZ3}| + |F_{KonstY3}| = 865,67 \text{ N}$$

$$F_{KonstE4} = |F_{KonstZ4}| + |F_{KonstY4}| = 865,67 \text{ N}$$

During the deceleration phase

$$F_{VerzE1} = |F_{VerzZ1}| + |F_{VerzY1}| = 821,50 \text{ N}$$

$$F_{VerzE2} = |F_{VerzZ2}| + |F_{VerzY2}| = 821,50 \text{ N}$$

$$F_{VerzE3} = |F_{VerzZ3}| + |F_{VerzY3}| = 821,50 \text{ N}$$

$$F_{VerzE4} = |F_{VerzZ4}| + |F_{VerzY4}| = 821,50 \text{ N}$$

c) The static safety factor for the maximum load on the linear guide during the acceleration phase is calculated according to [2.1].

$$f_s = \frac{C_0}{F_{0MAX}} = \frac{30.500}{909,84} = 33,5$$

d) The active, dynamic, equivalent load is calculated according to [2.9]

$$S = S_1 + S_2 + S_3 = 4.000 \text{ mm}$$

$$F_{m1} = \sqrt[3]{\frac{1}{S} (F_{BeschE1}^3 * S_1 + F_{KonstE1}^3 * S_2 + F_{VerzE1}^3 * S_3)} =$$

$$= \sqrt[3]{\frac{1}{4.000} * (909,84^3 * 1.000 + 865,67^3 * 2.000 + 821,50^3 * 1.000)} = 866,79 \text{ N}$$

$$F_{m2} = \sqrt[3]{\frac{1}{S} (F_{BeschE2}^3 * S_1 + F_{KonstE2}^3 * S_2 + F_{VerzE2}^3 * S_3)} =$$

$$= \sqrt[3]{\frac{1}{4.000} * (909,84^3 * 1.000 + 865,67^3 * 2.000 + 821,50^3 * 1.000)} = 866,79 \text{ N}$$

$$F_{m3} = \sqrt[3]{\frac{1}{S} \left(F_{BeschE3}^3 * S_1 + F_{KonstE3}^3 * S_2 + F_{VerzE3}^3 * S_3 \right)} =$$

$$= \sqrt[3]{\frac{1}{4.000} * \left(909,84^3 * 1.000 + 865,67^3 * 2.000 + 821,50^3 * 1.000 \right)} = 866,79 \text{ N}$$

$$F_{m4} = \sqrt[3]{\frac{1}{S} \left(F_{BeschE4}^3 * S_1 + F_{KonstE4}^3 * S_2 + F_{VerzE4}^3 * S_3 \right)} =$$

$$= \sqrt[3]{\frac{1}{4.000} * \left(909,84^3 * 1.000 + 865,67^3 * 2.000 + 821,50^3 * 1.000 \right)} = 866,79 \text{ N}$$

e) The nominal service life time is calculated according to [2.5].

$$L_1 = \left(\frac{C}{F_{m1}} * \frac{f_H * f_T * f_C}{f_w} \right)^3 * 5 * 10^4 = \left(\frac{17.710}{866,79} * \frac{1}{2,0} \right)^3 * 5 * 10^4 = 53.515.380 \text{ m} = 53.515 \text{ km}$$

Example 4

Horizontal installation position (e.g. transport frame) with inertial forces, 2 rails arranged in parallel, 2 carriages per rail, LGBCH25FN

- v=1 m/s
- t₁=1 s
- t₂=2 s
- t₃=1 s
- s=4 000 mm
- Mass m=150 kg
- Gravity constant=9,8 m/s²
- l₀=600 mm, l₁=400 mm, l₅=150 mm, l₆=500mm
- C=24,85 kN
- C₀=47,07 kN
- f_w=2,0 (according Table 2.3)

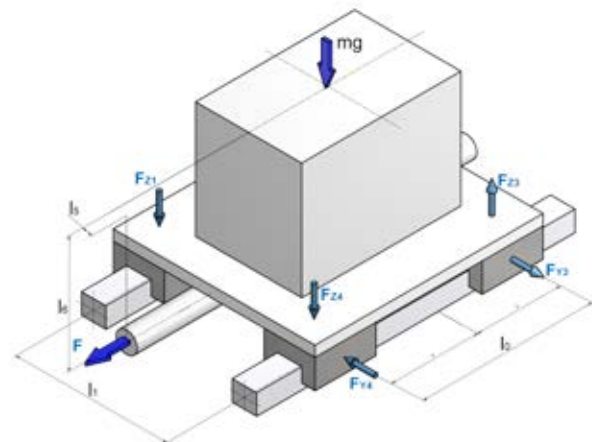


Figure 2.15 Calculation example 4

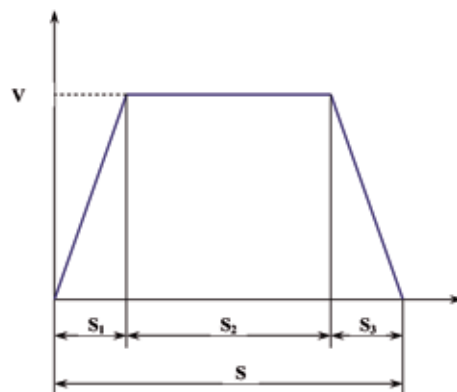


Figure 2.16 Velocity/distance diagram

Calculation:

a) Distance and acceleration calculation

$$\text{Acceleration phase: } a_1 = \frac{V}{t_1} = \frac{1}{1} = 1 \text{ m/s}^2$$

$$\text{Deceleration phase } a_3 = \frac{V}{t_3} = \frac{1}{1} = 1 \text{ m/s}^2$$

b) The active loads are calculated per carriage

During the acceleration phase

Radial loads

$$F_{BeschZ1} = F_{BeschZ4} = \frac{mg}{4} - \frac{m * a_1 * l_6}{2 * l_0} = \frac{150 * 9,8}{4} - \frac{150 * 1 * 500}{2 * 600} = 305 \text{ N}$$

$$F_{BeschZ3} = F_{BeschZ2} = \frac{mg}{4} + \frac{m * a_1 * l_6}{2 * l_0} = \frac{150 * 9,8}{4} + \frac{150 * 1 * 500}{2 * 600} = 430 \text{ N}$$

Tangential loads

$$F_{BeschY1} = F_{BeschY2} = F_{BeschY3} = F_{BeschY4} = \frac{m * a_1 * l_5}{2 * l_0} = \frac{150 * 1 * 150}{2 * 600} = 18,75 \text{ N}$$

At constant velocity

Radial loads

$$F_{KonstZ1} = F_{KonstZ2} = F_{KonstZ3} = F_{KonstZ4} = \frac{mg}{4} = \frac{150 * 9,8}{4} = 367,5 \text{ N}$$

During the deceleration phase

Radial loads

$$F_{VerzZ1} = F_{VerzZ4} = \frac{mg}{4} + \frac{m * a_3 * l_6}{2 * l_0} = \frac{150 * 9,8}{4} + \frac{150 * 1 * 500}{2 * 600} = 430 \text{ N}$$

$$F_{VerzZ2} = F_{VerzZ3} = \frac{mg}{4} - \frac{m * a_3 * l_6}{2 * l_0} = \frac{150 * 9,8}{4} - \frac{150 * 1 * 500}{2 * 600} = 305 \text{ N}$$

Tangential loads

$$F_{VerzY1} = F_{VerzY2} = F_{VerzY3} = F_{VerzY4} = \frac{m * a_3 * l_5}{2 * l_0} = \frac{150 * 1 * 150}{2 * 600} = 18,75 \text{ N}$$

c) The equivalent radial and tangential loads are calculated per carriage according to [2.8].

During the acceleration phase

$$F_{BeschE1} = F_{BeschE4} = |F_{BeschZ1}| + |F_{BeschY1}| = 323,75 \text{ N}$$

$$F_{BeschE2} = F_{BeschE3} = |F_{BeschZ2}| + |F_{BeschY2}| = 448,75 \text{ N}$$

At constant velocity

$$F_{KonstE1} = F_{KonstE2} = F_{KonstE3} = F_{KonstE4} = 367,5 \text{ N}$$

During the deceleration phase

$$F_{VerzE1} = F_{verzE4} = |F_{VerzZ1}| + |F_{VerzY1}| = 448,75 \text{ N}$$

$$F_{VerzE2} = F_{verzE3} = |F_{VerzZ2}| + |F_{VerzY2}| = 323,75 \text{ N}$$

d) The static safety factor for the maximum load on the linear guide during the acceleration and deceleration phase is calculated according to [2.1].

$$f_s = \frac{C_0}{F_{0MAX}} = \frac{41.070}{448,75} = 91,5$$

e) The active, dynamic, equivalent load is calculated according to [2.9].

$$F_{m1} = F_{m4} = \sqrt[3]{\frac{1}{S} (F_{BeschE1}^3 * S_1 + F_{KonstE1}^3 * S_2 + F_{VerzE1}^3 * S_3)} =$$

$$= \sqrt[3]{\frac{1}{4.000} * (323,75^3 * 1.000 + 367,5^3 * 2.000 + 448,75^3 * 1.000)} = 382,3 \text{ N}$$

$$F_{m2} = F_{m3} = \sqrt[3]{\frac{1}{S} (F_{BeschE2}^3 * S_1 + F_{KonstE2}^3 * S_2 + F_{VerzE2}^3 * S_3)} =$$

$$= \sqrt[3]{\frac{1}{4.000} * (448,75^3 * 1.000 + 367,5^3 * 2.000 + 323,75^3 * 1.000)} = 382,3 \text{ N}$$

f) The service life time of the four carriages is calculated according to [2.5].

$$L = \left(\frac{C}{F_{m1}} * \frac{f_H * f_T * f_C}{f_W} \right)^3 * 5 * 10^4 = \left(\frac{24.850}{382,3} * \frac{1}{2,0} \right)^3 * 5 * 10^4 = 1.716.509.860 \text{ m} = 1.716.510 \text{ km}$$

2.6 Preload/rigidity

2.6.1 Preload classes

Linear guides can be preloaded to increase the rigidity of the system or to improve the spring compression behaviour of the total system. The elastic deformation of the tracks and the balls under load is smaller for preloaded carriages than in non-preloaded ones. The disadvantages of preloaded systems are: increased driving resistance and a resulting reduction in service life time. The preload is not considered in the normal service life time calculation when it is within the ranges specified in Table 2.6. The preload in a linear guide system is achieved by using rolling elements that are oversized by a specific factor (Figure 2.17). The preload is defined by the radial clearance resulting from the over sizing of the rolling elements.

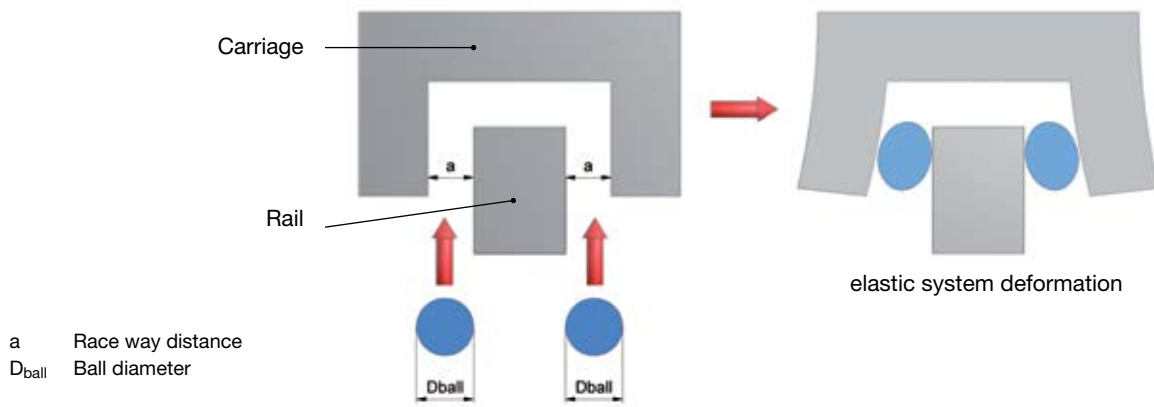


Figure 2.17 Preloading by over sizing of the balls

NTN-SNR linear guides are produced in different preload classes (Table 2.6). The individual preload classes correspond to a preload of the rolling elements that is defined by a percentage rate of the dynamic load rating C.

Table 2.6 Preload class

	Description	Preload class
No preload	Z0	0
Low preload	Z1	up to 2% of C
Medium preload	Z2	up to 4% of C
High preload	Z3	up to 8% of C
Special preload	ZX	According customer request

Example for the selection of the preload class

Table 2.7 Application areas for different preload classes

	Without preload (Z0)	Low preload (Z1)	Medium and high preload (Z2/Z3)
Application conditions	<ul style="list-style-type: none"> > Two-rail system > Weak external effects > Low load > Low friction > Low accuracy 	<ul style="list-style-type: none"> > One-rail system > Low load > High accuracy > Self-supporting design > High dynamics 	<ul style="list-style-type: none"> > Strong vibrations > High-performance processing > Strong external effects
Applications	<ul style="list-style-type: none"> > Welding machines > Cutting machines > Feeding systems > Tool changer > X and Y axes for general industrial applications > Packaging machines 	<ul style="list-style-type: none"> > Precision coordinate tables > Manipulators > Z-axes for general industrial applications > Measuring devices > PC-board drilling machines 	<ul style="list-style-type: none"> > Processing centres > NC turning machine > Milling machines > Grinding machines

Table 2.8 Radial clearance of linear guides [µm]

	Z0	Z1	Z2	Z3
LGM...07	-2...+2	-3...0	-	-
LGM...09	-2...+2	-3...0	-	-
LGM...12	-3...+3	-6...0	-	-
LGM...15	-5...+5	-10...0	-	-
LGB...15	-3...+3	-8...-4	-13...-9	-18...-14
LGB...20	-3...+3	-8...-4	-14...-9	-19...-14
LGB...25	-4...+4	-10...-5	-17...-11	-23...-18
LGB...30	-4...+4	-11...-5	-18...-12	-25...-19
LGB...35	-5...+5	-12...-6	-20...-13	-27...-20
LGB...45	-6...+6	-15...-7	-23...-15	-32...-24
LGB...55	-7...+7	-19...-8	-29...-20	-38...-30

We recommend that you contact our NTN-SNR application engineers to select the optimal preload.

2.6.2 Rigidity

The rigidity of a carriage is defined by the relationship between the external load and the resulting elastic deformation in the load direction. The rigidity is an important parameter for the selection of the system, as the rigidity values vary according to the type and version of the NTN-SNR linear guide systems. The rigidity values discriminate between deformation due to load in the main load directions (Figure 2.18) and angular deformation due to torque load (Figure 2.19).

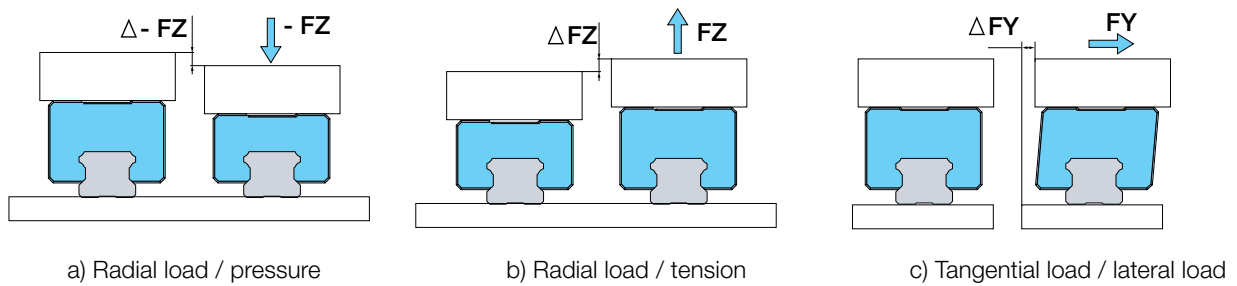


Figure 2.18 Deformation due to load in the main load directions

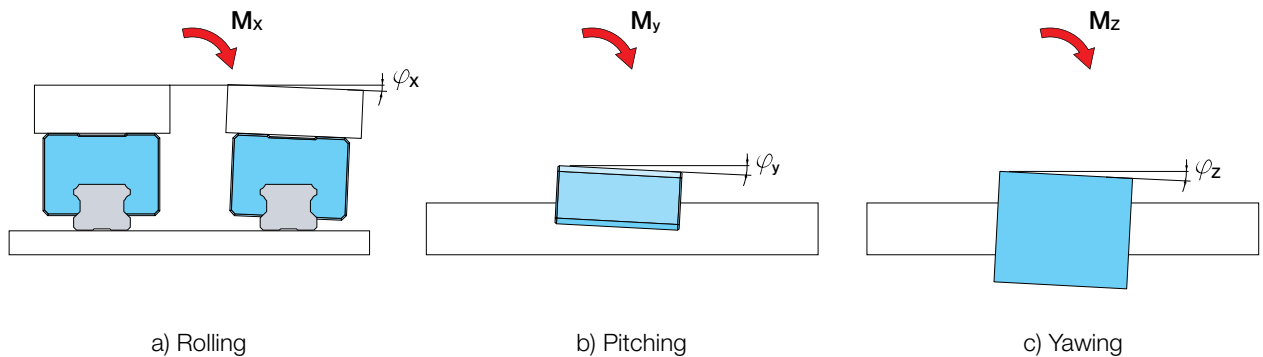


Figure 2.19 Angular deformation due to torque load

2.7. Precision

2.7.1 Precision grades

NTN-SNR linear guides are produced in various precision classes. Each precision class has a maximum deviation for running parallelism and maximum dimensional deviations. (Figure 2.20).

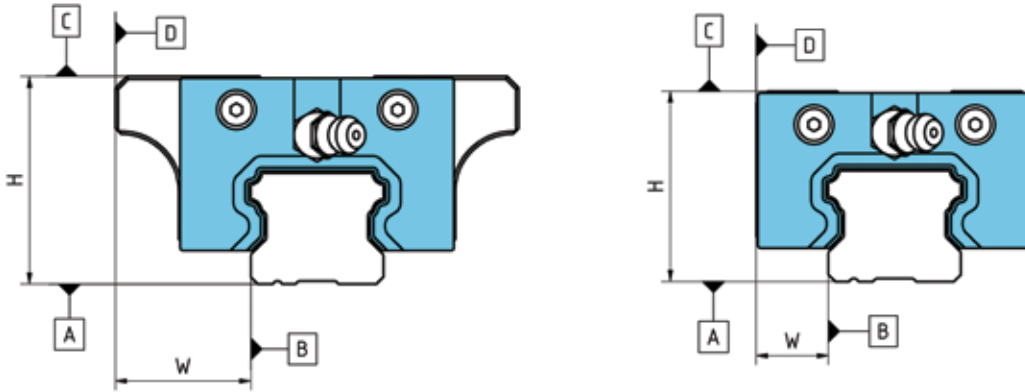


Figure 2.20 Precision classes

The running parallelism ΔC describes the maximum parallelism deviation between the top of the carriage and the bottom of the rail, relative to the length of the rail. ΔD is the the maximum parallelism deviation between the lateral reference surface of the carriage and the rail, relative to the length of the rail. The height tolerance is the maximum dimensional deviation of the height measurement H in the z -direction between the top of the carriage and the bottom of the rail. The maximum dimensional deviation between the lateral reference surface of the carriage and the rail in y -direction is the tolerance of the value W . The values for the individual precision classes are provided in Table 2.9 for the standard linear guides and in Table 2.10 for the miniature guides.

Table 2.9 Precision classes of the standard guides

	Normal precision (N)	H precision (H)	P precision (P)	SP precision (S)	UP precision (U)
Height tolerance (H)	$\pm 0,1$	$\pm 0,04$	0 -0,04	0 -0,02	0 -0,01
Width tolerance (W)	$\pm 0,1$	$\pm 0,04$	0 -0,04	0 -0,02	0 -0,01
Height difference (ΔH) *	0,03	0,02	0,01	0,005	0,003
Width difference (ΔW) *	0,03	0,02	0,01	0,005	0,003
Running parallelism between carriage surface C and the rail surface A	See Figure 2.21.				
Running parallelism between the carriage reference reference surface D and the rail reference surface B	See Figure 2.21.				

* between two carriages

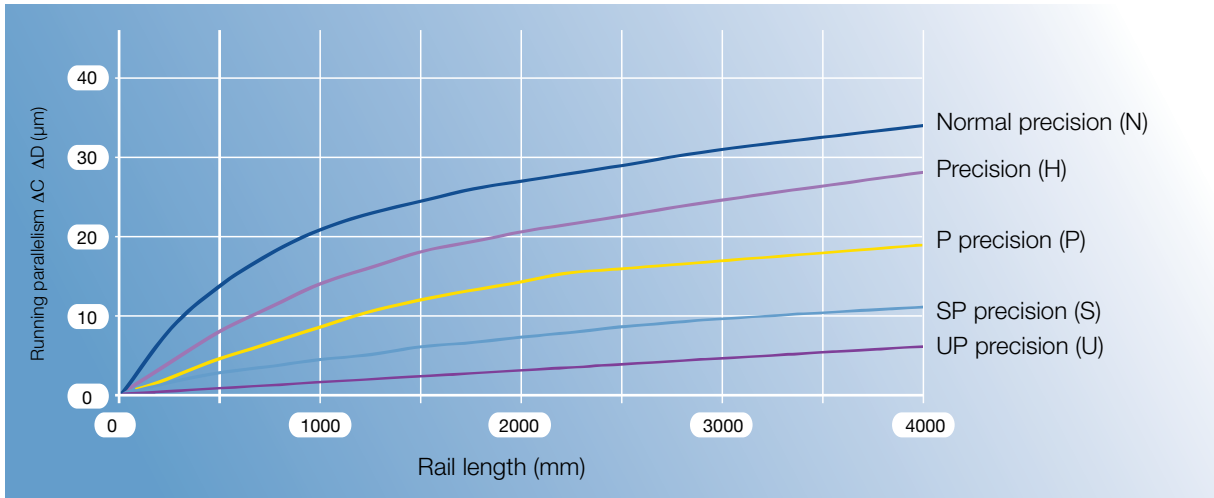


Figure 2.21 Running parallelism of the standard linearguides

Table 2.10 Precision classes of the miniature guides

	Normal precision (N)	H precision (H)	P precision (P)
Height tolerance (H)	± 0,04	± 0,02	± 0,01
Width tolerance (W)	± 0,04	± 0,025	± 0,015
Height difference (ΔH) *	0,03	0,015	0,007
Width difference (ΔW) *	0,03	0,02	0,01
Running parallelism between carriage surface C and the rail surface A	See Figure 2.22.		
Running parallelism between the carriage reference reference surface D and the rail reference surface B	See Figure 2.22.		

* between two carriages

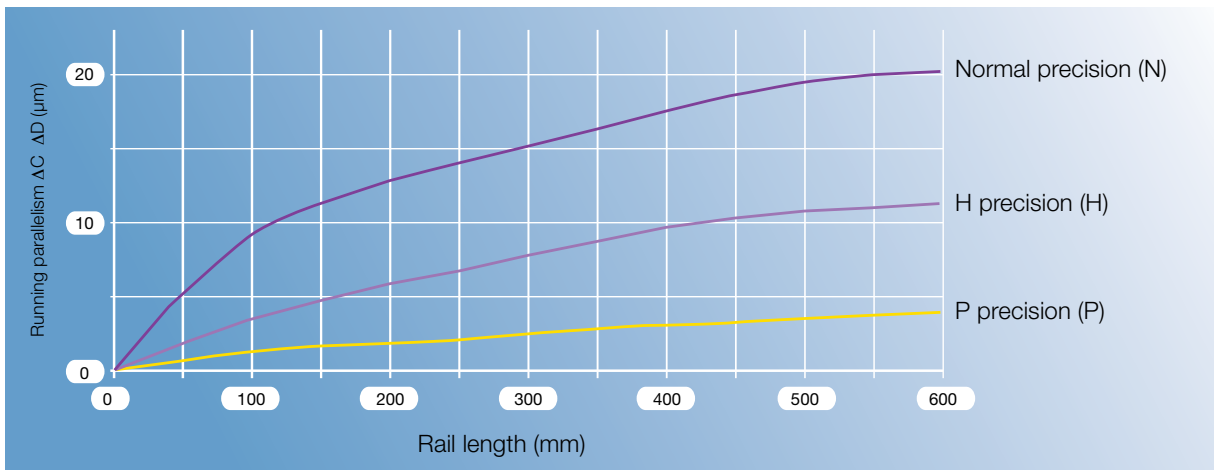


Figure 2.22 Running parallelism of the miniature guides

2.7.2 Interchangeability

It is not possible to make the NTN-SNR linear guides in all precision and preload classes interchangeable, as this would interfere with our goal of ensuring top quality. High precision and preload classes are therefore only available as sets consisting of rails and carriages. Table 2.11 contains an overview of the exchange options.

Table 2.11 Interchangeability of standard linear guides

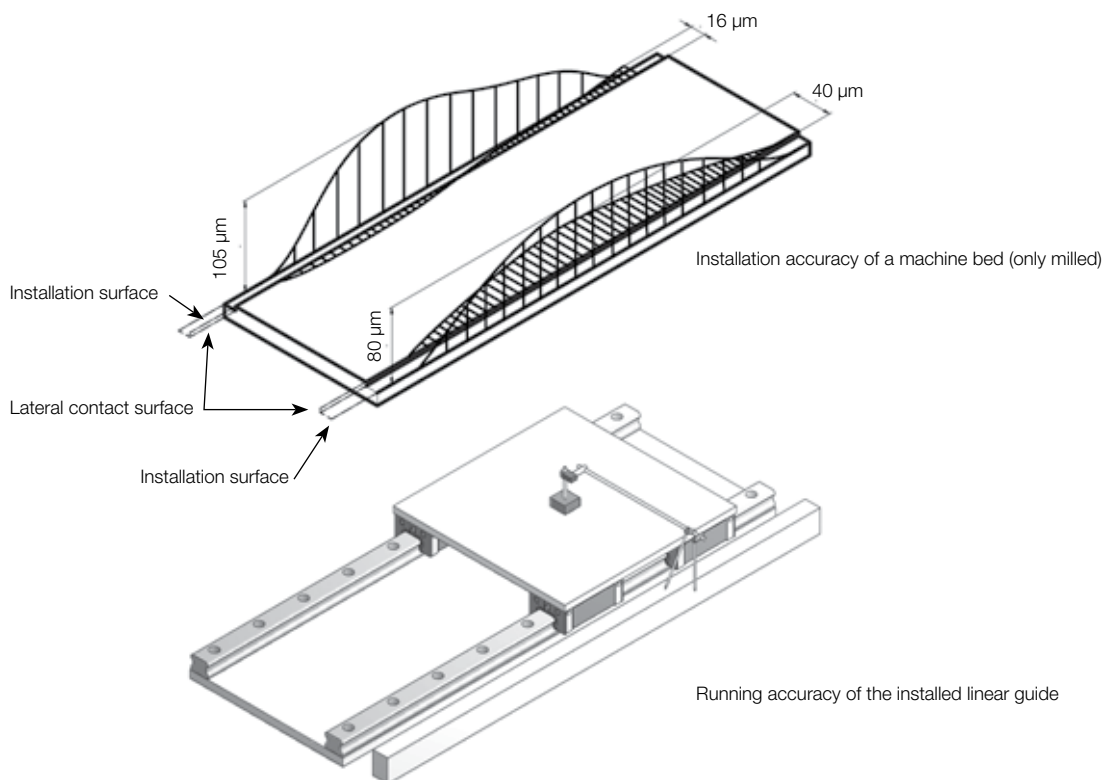
Precision class		interchangeable			not interchangeable				
		N	H	P	N	H	P	S	U
Preload class	LGB	Z0	Z0	Z0	-	-	-	-	-
		Z1	Z1	Z1	-	-	-	Z1	Z1
		Z2	Z2	Z2	-	-	-	Z2	Z2
		-	-	-	Z3	Z3	Z3	Z3	Z3
		-	-	-	ZX	ZX	ZX	ZX	ZX
	LGM	-	-	-	Z0	Z0	Z0	-	-
		-	-	-	Z1	Z1	Z1	-	-
		-	-	-	ZX	ZX	ZX	-	-
		-	-	-	-	-	-	-	-

2.7.3 Error compensation

Each component and each support structure on which linear guides are to be mounted has straightness, evenness and parallelism variance. Inaccuracies also occur as a result of installation faults. A significant number of these errors can be compensated for by the special track geometry with DF configuration of the NTN-SNR linear guides, as long as the supporting structure is sufficiently rigid (Figure 2.23).

The fault compensation effect usually improves the running accuracy of a machine table by more than 80% compared with the initial surfaces.

Figure 2.23 Error compensation



2.8 Drive power

2.8.1 Friction

Linear guides basically consist of a carriage a rail and rolling elements that move between the tracks of the carriage and the rail. A friction force F_R occurs, as with any movement (Figure 2.24). The friction coefficient (μ) is mainly affected by the following factors:

- > Load (F)
- > Preload
- > Osculation
- > Design principle (circular arc groove or Gothic arc groove)
- > Rolling element shape
- > Material combinations in the runner block
- > Lubricant

The stick-slip effect at start-up, so familiar with sliding guides, hardly occurs.

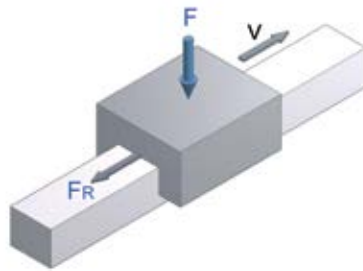
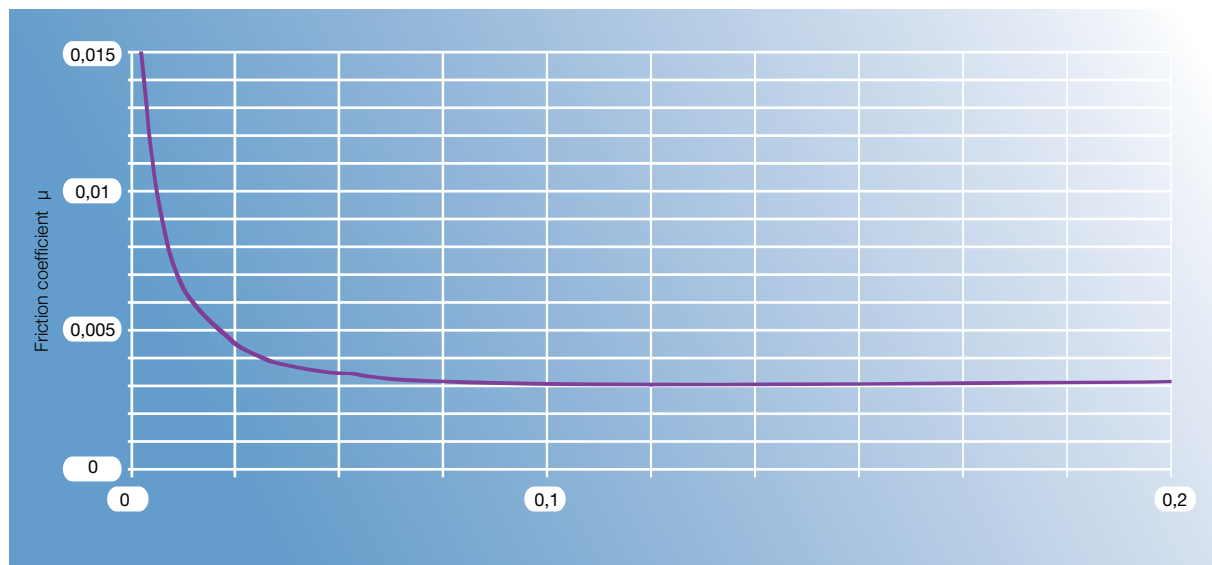


Figure 2.24 Friction force

Figure 2.25 Ratio of load / friction coefficient of linear guides with balls



NTN-SNR linear guides with balls as rolling elements have a friction coefficient (μ) of approx. 0.003 (Figure 2.25). The forces acting on the system include internal as well as external forces. The external forces may be weight forces, process forces (e.g. milling forces) and dynamic forces (e.g. acceleration forces). Internal forces result from preload, assembly tolerances and installation faults.

The friction caused by the lubricant strongly depends on the properties of the lubricant used. Immediately after relubrication, the friction forces of a linear guide increase for a short time. After some rolling movements of the rolling elements, the optimal grease distribution of the system is again reached and the friction force drops to its normal value.

2.8.2 Driving resistance

The driving resistance of a linear guide consists of the friction force and the sealing resistance (Figure 2.26).

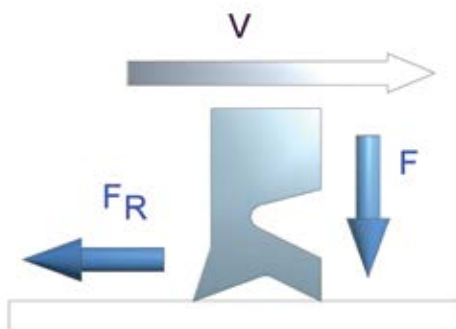


Figure 2.26 Friction force of a two-lip seal

The seal resistance is in turn dependent on the respective combination of seals used. The standard configuration of NTN-SNR linear guides includes an inner seal (not for miniature guides), two lateral seals and end seals on both sides. All seals are implemented as two-lip seals. The maximum sealing resistances are shown in Table 2.12.

Table 2.12 Maximum sealing resistances

Series	Sealing resistance N	Series	Sealing resistance N
LGB_15_S	1,7	LGB_45_N	11,2
LGB_15_N	2,2	LGB_45_L	12,2
LGB_15_L	2,4	LGB_45_E	14,0
LGB_15_E	2,8	LGB_55_N	13,5
LGB_20_S	2,7	LGB_55_L	15,8
LGB_20_N	3,5	LGB_55_E	16,8
LGB_20_L	3,9		
LGB_20_E	4,5	LGM_07BN	0,2
LGB_25_S	4,0	LGM_09BN	0,3
LGB_25_N	5,2	LGM_09BL	0,4
LGB_25_L	5,9	LGM_09WN	0,4
LGB_25_E	6,6	LGM_09WL	0,5
LGB_30_S	5,4	LGM_12BN	0,7
LGB_30_N	7,1	LGM_12BL	0,8
LGB_30_L	8,0	LGM_12WN	0,8
LGB_30_E	9,0	LGM_12WL	0,9
LGB_35_S	6,8	LGM_15BN	0,9
LGB_35_N	8,8	LGM_15BL	1,0
LGB_35_L	9,9	LGM_15WN	1,1
LGB_35_E	11,2	LGM_15WL	1,2

2.8.3 Driving force

The driving force for a linear guide system (Figure 2.27) is calculated according to the following formula:

$$F_a = \mu \cdot F + n \cdot f \quad [2.13]$$

- F_a: Driving force [N]
- μ: Friction value
- F: Load [N]
- n: Number of runner blocks
- f: Specific movement resistance of a carriage [N]

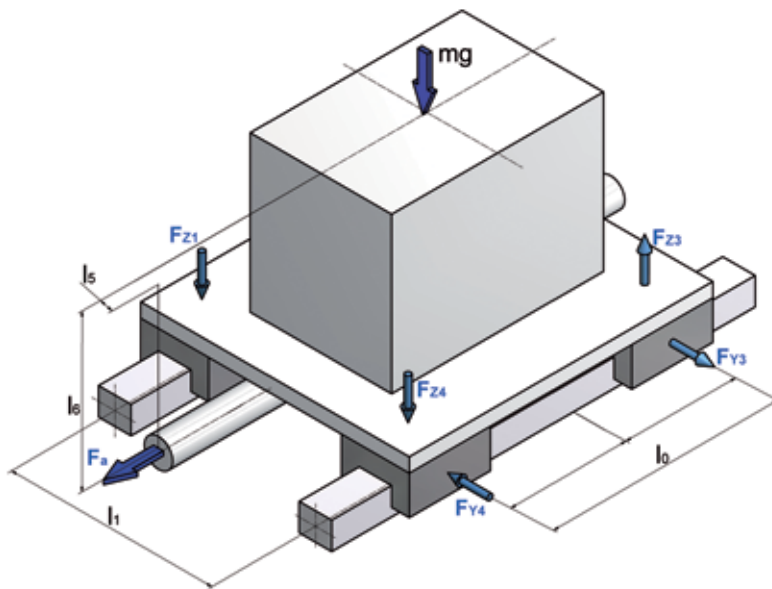


Figure 2.27 Driving force calculation

The maximum driving resistances shown in Table 2.13 result for NTN-SNR linear guides with standard sealing and greasing at room temperature and without load. This value may vary considerably when different sealing options or grease types are chosen.

Table 2.13 Driving resistances

Series	Z0 [N]	Z1 [N]	Z2 [N]	Z3 [N]
LGBC_15_S	2,9	3,3	3,7	4,1
LGBC_15_N	3,7	4,6	5,4	6,3
LGBC_15_L	4,2	5,3	6,2	7,3
LGBC_15_E	4,9	6,2	7,3	8,6
LGBC_20_S	4,4	5,1	5,7	6,4
LGBC_20_N	5,8	7,1	8,2	9,6
LGBC_20_L	6,6	8,4	9,8	11,6
LGBC_20_E	7,6	9,7	11,4	13,5
LGBC_25_S	6,3	7,2	8,0	9,0
LGBC_25_N	8,3	10,0	11,7	13,5
LGBC_25_L	9,6	11,8	13,9	16,3
LGBC_25_E	10,7	13,2	15,6	18,3
LGBC_30_S	8,3	9,6	10,8	12,2
LGBC_30_N	11,1	13,6	16,1	18,9
LGBC_30_L	12,8	16,1	19,3	22,9
LGBC_30_E	14,3	17,9	21,5	25,5
LGBC_35_S	10,6	12,4	14,1	16,1
LGBC_35_N	14,3	17,9	21,3	25,2
LGBC_35_L	16,3	20,8	25,0	30,0
LGBC_35_E	18,4	23,3	28,0	33,4
LGBC_45_N	18,5	23,3	27,9	33,3
LGBC_45_L	20,7	26,4	31,9	38,3
LGBC_45_E	23,7	30,3	36,6	44,0
LGBC_55_N	22,6	28,1	33,8	40,3
LGBC_55_L	27,2	34,6	42,3	51,0
LGBC_55_E	31,0	41,1	51,5	63,3

Series	Z0 [N]	Z1 [N]	Z2 [N]	Z3 [N]
LGBX_15_S	2,4	2,9	3,3	3,7
LGBX_15_N	3,2	4,1	4,9	5,8
LGBX_15_L	3,6	4,7	5,6	6,7
LGBX_15_E	4,3	5,6	6,7	8,0
LGBX_20_S	3,8	4,5	5,0	5,7
LGBX_20_N	5,0	6,4	7,5	8,8
LGBX_20_L	5,8	7,5	9,0	10,7
LGBX_20_E	6,6	8,7	10,4	12,5
LGBX_25_S	5,5	6,4	7,2	8,2
LGBX_25_N	7,4	9,1	10,7	12,6
LGBX_25_L	8,5	10,7	12,8	15,2
LGBX_25_E	9,5	12,0	14,4	17,1
LGBX_30_S	7,4	8,6	9,9	11,2
LGBX_30_N	10,0	12,6	15,0	17,8
LGBX_30_L	11,6	14,9	18,1	21,7
LGBX_30_E	12,9	16,6	20,1	24,1
LGBX_35_S	9,5	11,3	13,0	15,0
LGBX_35_N	13,0	16,6	20,0	24,0
LGBX_35_L	14,9	19,4	23,6	28,5
LGBX_35_E	16,8	21,7	26,4	31,8
LGBX_45_N	16,9	21,6	26,3	31,7
LGBX_45_L	18,8	24,5	30,0	36,4
LGBX_45_E	21,6	28,2	34,5	41,9
LGBX_55_N	20,6	26,1	31,7	38,2
LGBX_55_L	24,8	32,2	39,8	48,6
LGBX_55_E	28,2	38,3	48,7	60,5

3 Installation

3.1 Arrangement of the installation surface

The installation of linear guides usually involves two guide rails arranged in parallel with one or several carriages per rail guide. The example shown is a common application, in which the rail guides are fastened at a specific distance to each other on an even support surface (e.g. a machine bed) and in which a machine table is attached to the carriages (Figure 3.1).

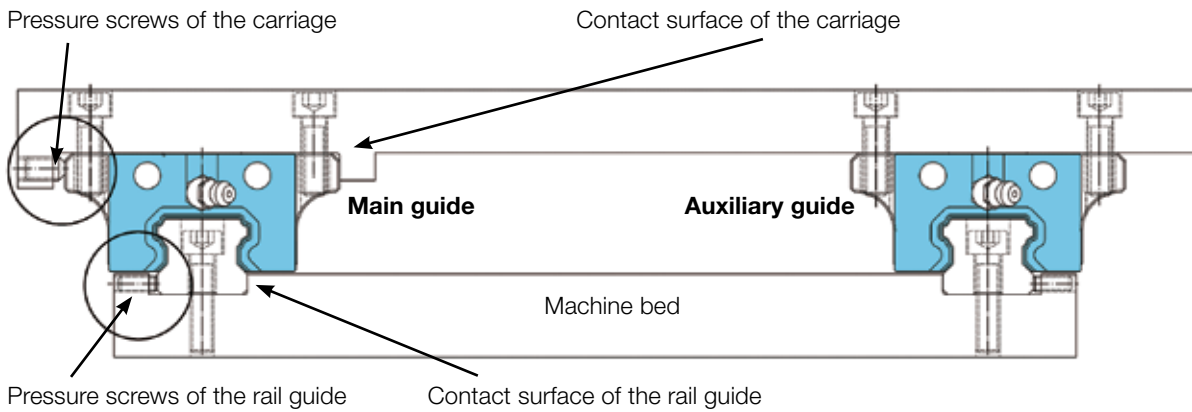


Figure 3.1 Installation for application with two linear guides arranged in parallel

The locating edges are used to achieve accurate positioning during installation. The locating edges also make the installation of the whole system easier. The information about the height of the locating edge H_r for the rail guide (Figure 3.2) and the height of the locating edge H_s for the carriage (Figure 3.3) is provided in Table 3.1 and Table 3.2.

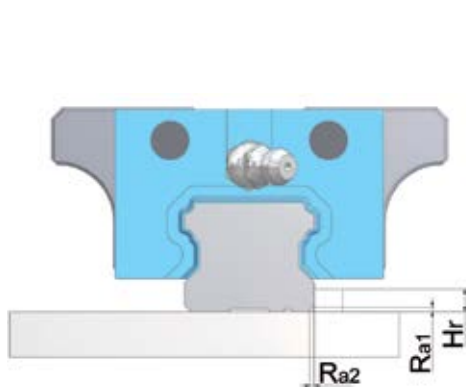


Figure 3.2. Locating edge of the carriages

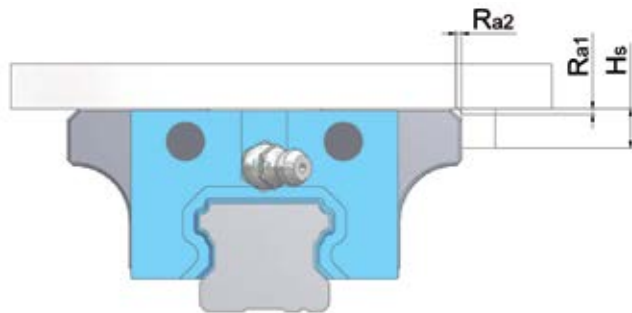


Figure 3.3. Locating edge of the carriages

Table 3.1 Locating edges and edge radius for the LGB series.

	Edge radius Ra1=Ra2 [mm]	Z Alignment edge Hr [mm]	Alignment edge Hs [mm]	Fastening screws*
LGB...15	0,6	3,1	5	M4x16
LGB...20	0,9	4,3	6	M5x20
LGB...25	1,1	5,6	7	M6x25
LGB...30	1,4	6,8	8	M8x30
LGB...35	1,4	7,3	9	M8x30
LGB...45	1,6	8,7	12	M12x35
LGB...55	1,6	11,8	14	M14x35

* Minimum screw length

Table 3.2 Locating edges and edge radius for the LGM series.

	Edge radius Ra1 [mm]	Edge radius Ra2 [mm]	Alignment edge Hr [mm]	Alignment edge Hs [mm]	Fastening screws*
LGM...07B	0,1	0,3	1,0	3,0	M2x5
LGM...09B	0,1	0,3	1,5	4,9	M3x6
LGM...09W	0,1	0,5	2,5	4,9	M3x6
LGM...12B	0,3	0,2	1,5	5,7	M3x6
LGM...12W	0,3	0,3	2,5	5,7	M3x8
LGM...15B	0,3	0,4	2,2	6,5	M3x8
LGM...15W	0,3	0,3	2,2	6,5	M3x8

* Minimum screw length

3.2 Identification of linear guides

In the use of linear guides with precision classes P and higher, that are installed in one plane (main guide and auxiliary guide) all carriages are marked with the same production code (Figure 3.4).



Figure 3.4 Marking the main and auxiliary guide

For accurate positioning in the adjacent construction carriages and guides respectively have a machined reference surface. The reference surfaces of the carriage are located on the side that is opposite the SNR logo / production code. The reference surface of the rail is marked by the narrow marking line at the bottom. Both reference surfaces exhibit when correctly installed in the same direction. (Figure 3.5).

We recommend that you contact our NTN-SNR application engineers when a different arrangement of the reference surfaces is required.

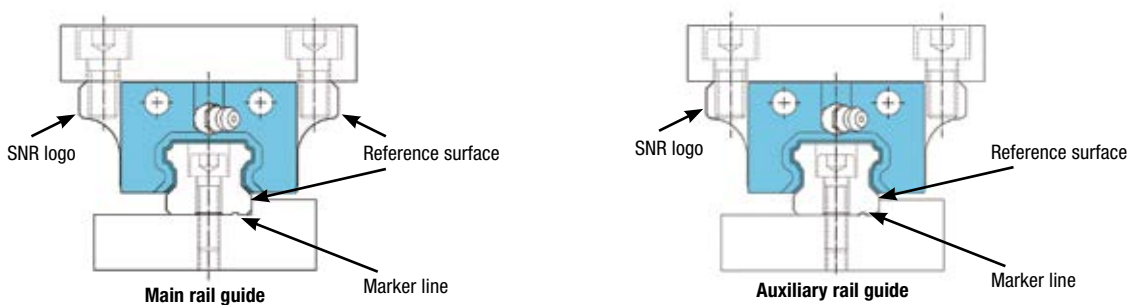


Figure 3.5 Marking the reference surfaces

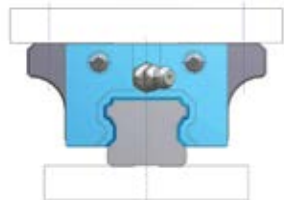
The linear guides are delivered in one piece up to a standard length of approximately 4000 mm. Longer linear guides are provided in several sections with joints. The joints are marked with "J" at the rail ends (Figure 3.6) and the rail segments can be freely combined.



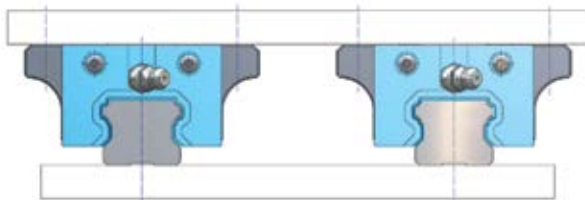
Figure 3.6 Identification of linear guides

3.3 Arrangement of linear guides

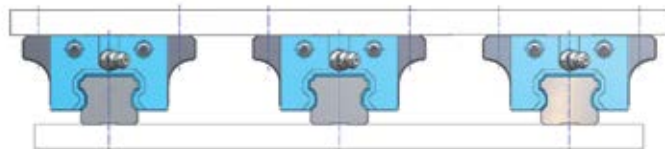
The following examples show some basic arrangements of linear guides that are most commonly used in practical applications (Figure 3.7).



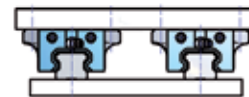
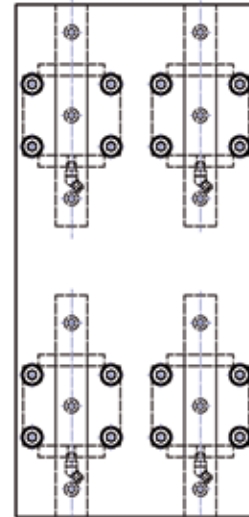
One-rail arrangement (1)



Two-rail arrangement (2)



Three-rail arrangement (3)



Four-rail arrangement (4)

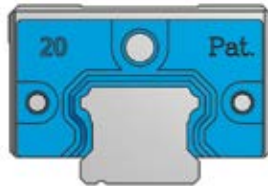
Figure 3.7 Examples for the arrangement of linear guides

The number of linear guides and the carriages in a total system has an impact on the rigidity, load-rating capacity and dimensions of the device. The arrangement of the linear guides also determines the requirements for the accuracy of the installation surfaces. The actual arrangement of linear guides strongly depends on the application and may therefore vary accordingly.

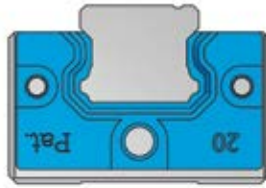
3.4 Installation position of a linear guide

The installation position of the linear guide system (carriage and rail guide) is defined by the basic concept of the machine/device (Figure 3.8). The lubrication process (lubricants, lubrication intervals, supply with lubricant) must be adapted to the installation position selected.

Rotation around the X-axis



Horizontal installation
without rotation
x - 0°



Overhead installation,
rotation by 180°
x - 180°

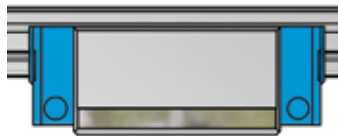


Tilted installation,
rotation by 0 to 180°
x - ...°

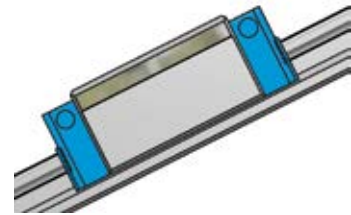
Rotation around the Y-axis



Horizontal installation
without rotation
y - 0°



Overhead installation,
rotation by 180°
y - 180°



Tilted installation,
rotation by 0 to 180°
y - ...°

Figure 3.8 Installation positions of a linear guide

3.5 Installation instructions

To assemble NTN-SNR linear guides properly and without affecting the safety and health of the personnel, the instructions and notes must be observed and followed.

- > Linear guides must be installed by authorized personnel.
- > Appropriate tools and aids to be used for the assembly.
- > Avoid temperature differences between the components to be assembled.
- > The steps are to perform specified order.
- > To prevent corrosion of the material surfaces are to wear cotton gloves when installing non-conserved components.
- > Take the components only at the installation site from the packaging to avoid any contamination of the components.

Example:

Parallel guiding system with 2 linear guides.
 Each the rail a shoulder edge and one shoulder edge for the carriages in the table.E

Step 1. Cleaning the installation surface

- Remove unevenness, burrs and dirt with as oilstone from the installation surface
- Clean the NTN-SNR linear guides
- Remove the anti-corrosion oil e. g. with a cotton cloth

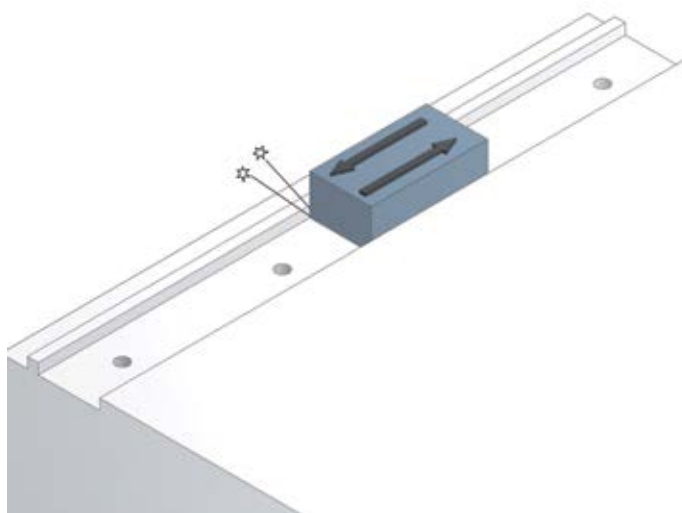


Figure 3.9 Preparation of the installation surface

Step 2. Alignment of the linear guide on the installation surface

- Place the rail onto the installation surface and fasten it slightly with the screws, so that the rail touches the installation surface
- Note the reference surface (marked with the narrow groove on the rail bottom)
- Align reference surface to the shoulder edge of the installation surface

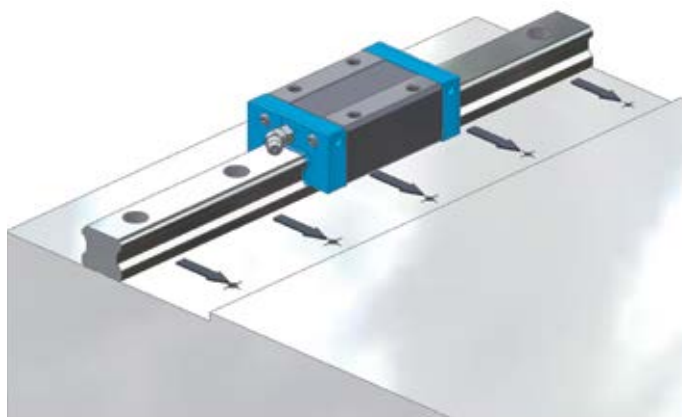


Figure 3.10 Aligning the linear guide

Step 3. Pre-installing the linear guide

- Slightly tighten the screws
- Align screw heads in the middle of the mounting holes from the rail
- Pre-assemble pressure screws

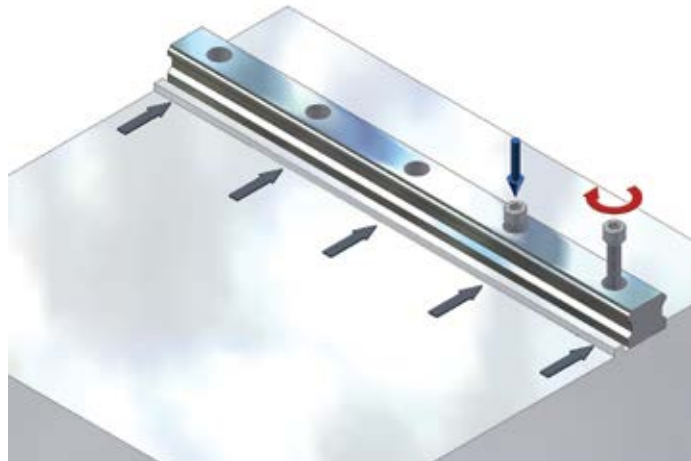


Figure 3.11 Pre-installing

Step 4. Fastening the pressure screws

- Tighten the pressure screws on the rail to achieve a lateral contact with the installation surface
- Note the necessary torque (chapter 3.7)
- Tighten the pressure screws sequentially by starting in the middle of the rail

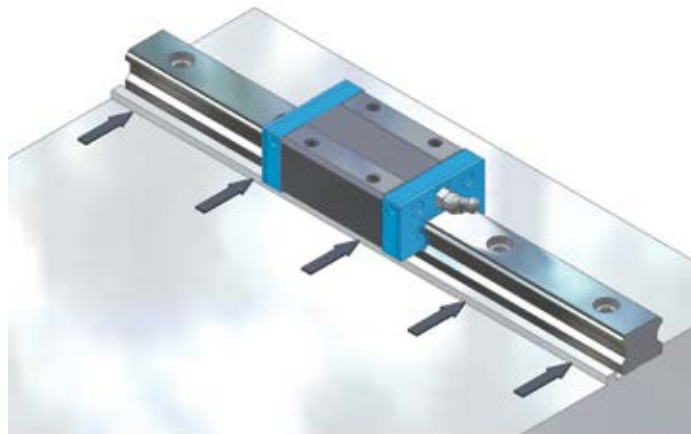


Figure 3.12 Positioning the rail

Step 5. Fastening the fastening screws with a torque spanner

- Tighten the mounting screws with the correct torque (chapter 3.7)
- Tighten the mounting screws sequentially by starting in the middle of the rail

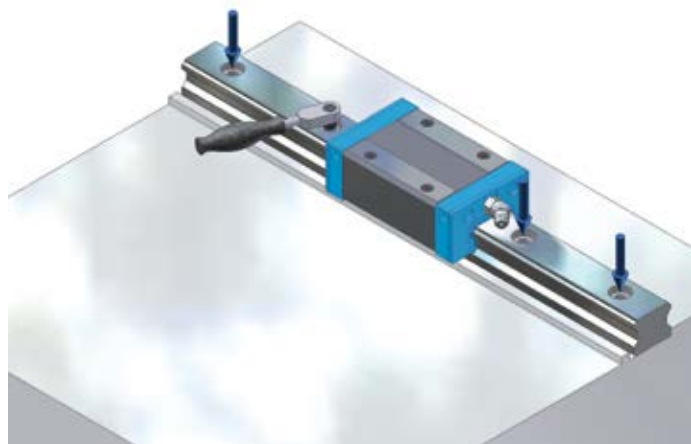


Figure 3.13 Final installation of the rail

Step 6. Installation of additional linear guides

Additional linear guides must be installed in the same order (Steps 1 to 5).

Step 7. Installation of the machine table

- Remove unevenness, burrs and dirt with as oilstone from the table plate
- Put the table carefully on the carriages and slightly tighten the mounting screws
- Positioning of the table by using of the lateral pressure screws from the table plate
- Tighten the mounting screws of the table in the specified order (crosswise)
- Start on the the reference side
- Note the necessary torque (chapter 3.7)

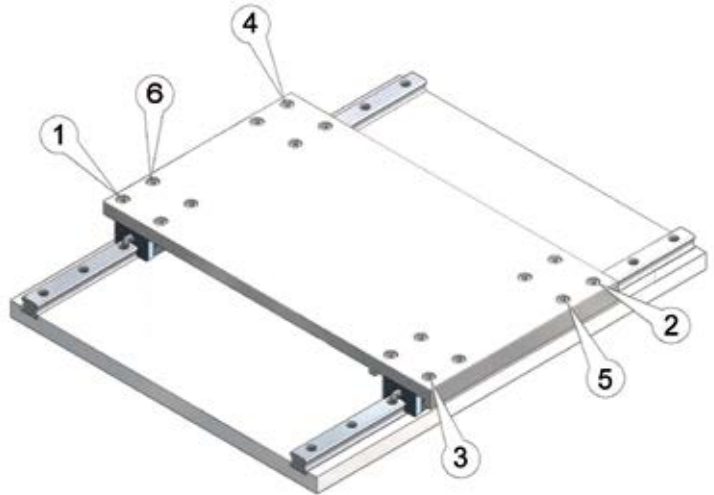


Figure 3.14 Fastening sequence for machine table installation

Step 8. Completing the assembly

- Assemble rail capsns
- Conserve system

3.6 Permitted installation tolerances

The service life of the linear guide system under normal operating conditions is not affected when the installation tolerances specified are not exceeded.

Parallelism tolerance between two rail guides

The parallelism tolerance between two linear guides (Figure 3.15) depends on the linear guide series used and the accuracy of the machine required. The maximum parallelism tolerances are provided in Table 3.3 and Table 3.4.

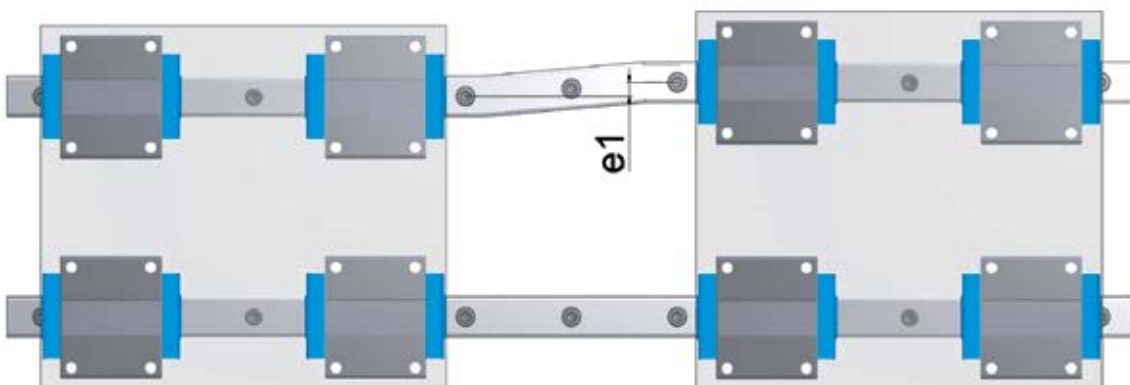


Figure 3.15 Parallelism tolerance between two linear guides e_1

Table 3.3 Parallelism tolerance e1 for the LGB series ..., [μm]

	e ₁			
	Z0	Z1	Z2	Z3
LGB...15	25	18	-	-
LGB...20	25	20	18	15
LGB...25	30	22	20	15
LGB...30	40	30	27	20
LGB...35	50	35	30	22
LGB...45	60	40	35	25
LGB...55	70	50	45	30

Table 3.4 Parallelism tolerance e1 for the LGM ..., [μm]

	e ₁	
	Z0	Z1
LGM...07	3	1
LGM...09	4	3
LGM...12	9	5
LGM...15	10	6

The values for the height tolerances (Figure 3.16) depend on the distance between the linear guides and are calculated using the conversion factor x (Table 3.5 and Table 3.6) and Formula [3.1].

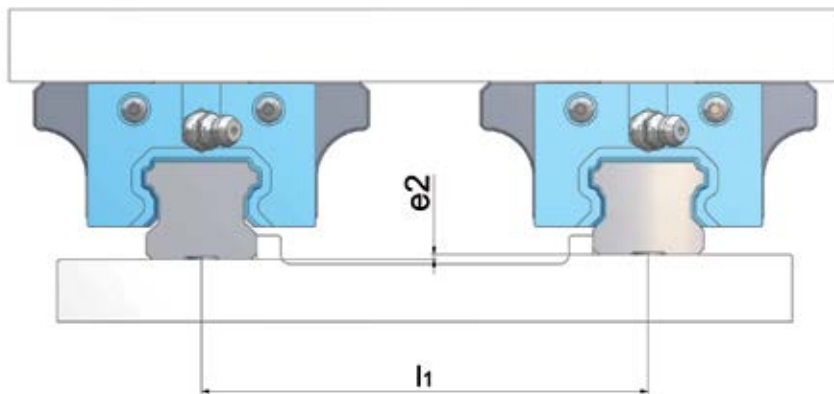


Figure 3.16 Height tolerance between two linear guides e₂

$$e_2 = l_1 * x \quad [3.1]$$

- e₂ Height tolerance of the mounting surface between two rails [µm]
- l₁ Distance between the rails [mm]
- x Calculation factors

Table 3.5 Calculation factors x for the LGB series ..., [µm]

	Z0	Z1	Z2	Z3
LGB...15	0,26	0,17	0,10	-
LGB...20	0,26	0,17	0,10	0,08
LGB...25	0,26	0,17	0,14	0,12
LGB...30	0,34	0,22	0,18	0,16
LGB...35	0,42	0,30	0,24	0,20
LGB...45	0,50	0,34	0,28	0,20
LGB...55	0,60	0,42	0,34	0,25

Table 3.6 Calculation factors x for the LGM series ..., [µm]

	e ₁	
	Z0	Z1
LGM...07	0,13	0,02
LGM...09	0,18	0,03
LGM...12	0,25	0,06
LGM...15	0,30	0,10

Height tolerance in a longitudinal direction between two carriages

The values for the height tolerances in a longitudinal direction (Figure 3.17) of the carriages are calculated using the conversion factor y (Tables 3.7 and 3.8) and Formula [3.2].

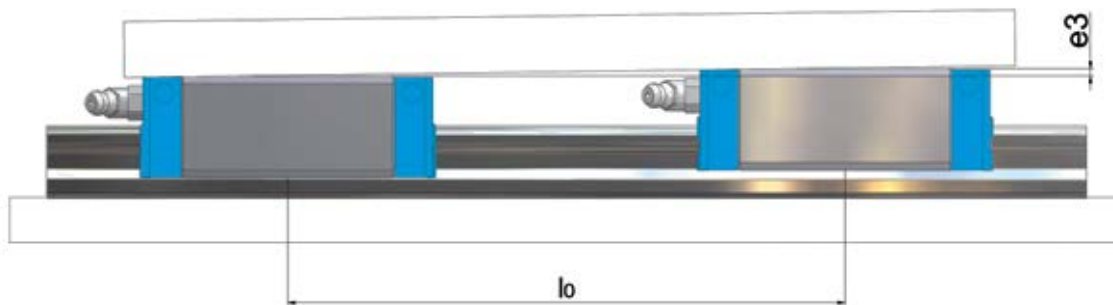


Figure 3.17 Height tolerance in longitudinal e_3

$$e_3 = l_0 * y \quad [3.2]$$

e_3 Height tolerance between two carriages [μm]
 l_0 Distance between the carriages [mm]
 y Calculation factors

Table 3.7 Calculation factors y for the LGB series ..., [μm]

	Z0	Z1	Z2	Z3
LGB_...15				
...BS / FS	0,14	0,11	0,09	0,07
...BN / FN	0,12	0,10	0,08	0,06
...BL / FL	0,11	0,09	0,07	0,06
...BE / FE	0,10	0,08	0,07	0,05
LGB_...20				
...BS / FS	0,15	0,12	0,10	0,08
...BN / FN	0,13	0,11	0,09	0,07
...BL / FL	0,12	0,10	0,08	0,06
...BE / FE	0,10	0,09	0,07	0,06
LGB_...25				
...BS / FS	0,17	0,14	0,12	0,09
...BN / FN	0,15	0,12	0,10	0,08
...BL / FL	0,14	0,11	0,09	0,07
...BE / FE	0,12	0,10	0,08	0,06
LGB_...30				
...BS / FS	0,21	0,17	0,14	0,11
...BN / FN	0,18	0,15	0,12	0,10
...BL / FL	0,16	0,13	0,11	0,09
...BE / FE	0,14	0,12	0,10	0,08
LGB_...35				
...BS / FS	0,29	0,24	0,20	0,15
...BN / FN	0,25	0,21	0,17	0,13
...BL / FL	0,23	0,19	0,15	0,12
...BE / FE	0,20	0,17	0,14	0,11
LGB_...45				
...BN / FN	0,30	0,25	0,20	0,16
...BL / FL	0,27	0,22	0,18	0,14
...BE / FE	0,24	0,20	0,16	0,13
LGB_...55				
...BN / FN	0,35	0,29	0,24	0,19
...BL / FL	0,32	0,26	0,21	0,17
...BE / FE	0,28	0,23	0,19	0,15

Table 3.8 Calculation factors y for the LGM ..., [μm]

	Z0	Z1
LGM_07		
...BN	0,07	0,04
LGM_09		
...BN / WN	0,10	0,08
...BL / WL	0,09	0,07
LGM_12		
...BN / WN	0,13	0,11
...BL / WL	0,12	0,10
LGM_15		
...BN / WN	0,17	0,14
...BL / WL	0,15	0,13

3.7 Fastening torques

The specific fastening torque strongly depends on the friction values. Different surfaces and lubrication conditions create a wide range of friction values. The mean friction coefficient for black-finished, non-lubricated screws is 0.14. The recommended fastening torques for fastening screws (Figure 3.18) of the Strength Classes 10.9 and 12.9 are provided in Table 3.9.

Table 3.9 Fastening torques for fastening screws (for $\mu=0,14$)

	Fastening torque [Nm]	
	Strength class 10.9	Strength class 12.9
M2	0,5	0,6
M2,5	1,0	1,2
M3	1,8	2,2
M4	4,4	5,1
M5	8,7	10
M6	15	18
M8	36	43
M10	72	84
M12	125	145
M14	200	235
M16	310	365

Screws of Strength class 12.9 should always be used for high dynamics, overhead installations or installations without a locating edge.

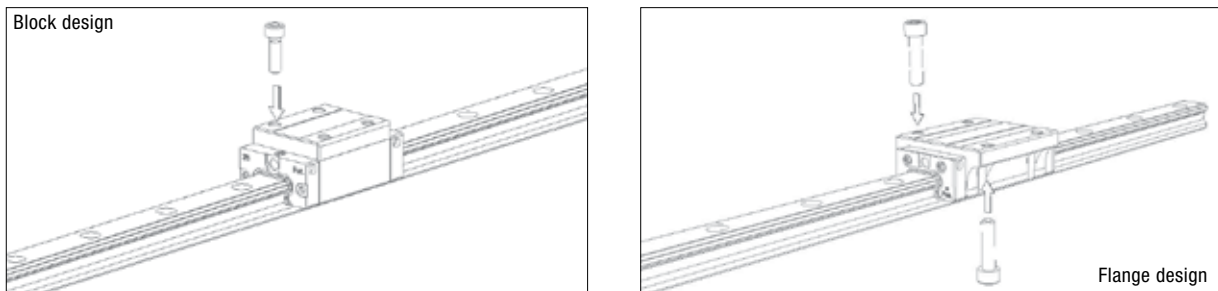


Figure 3.18 Mounting options of carriages

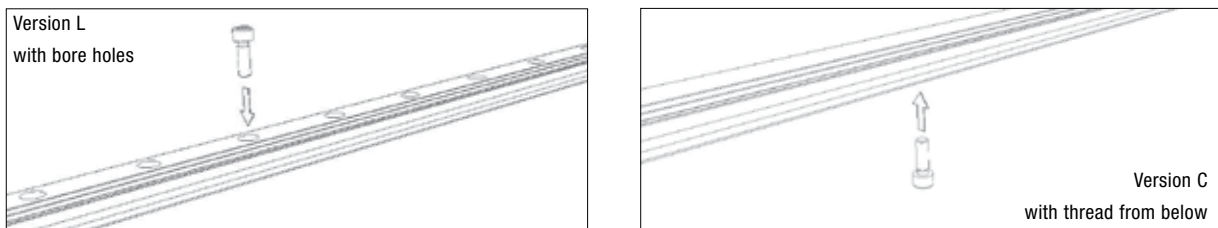


Bild 3.19 Mounting options of standard rails

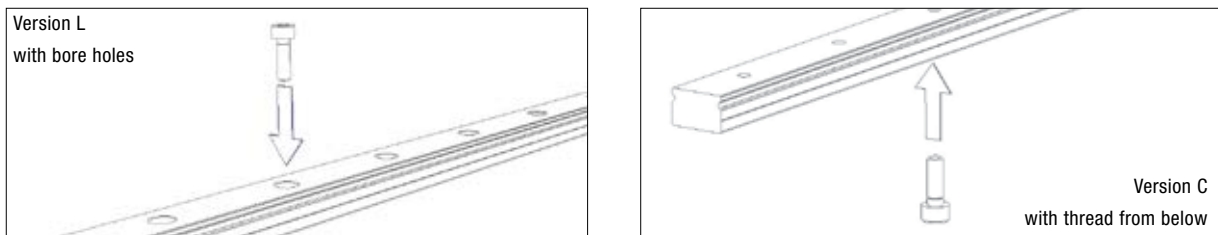


Bild 3.20 Mounting options of miniature rails

4 Lubrication

4.1. General information

Sufficient lubrication is essential for reliable function of the linear guide system. The lubrication intended to ensure a lubricating film (oil film) between the rolling elements and the race ways of the guiding elements to prevent wear and the premature fatigue of the components. In addition, the metallic surfaces are protected from corrosion. The lubricant film further facilitates jerk-free gliding of the seals over the surfaces and also reduces wear in these areas.

Insufficient lubrication not only increases wear but also significantly shortens the service life time. The selection of the optimal lubricant has a significant effect on the function and service life time of the linear guide system. Appropriate lubrication for the environmental temperature and the specific requirements must be determined to ensure that the function of the system is not restricted and remains available for a prolonged period.

Examples of such environmental conditions and influencing factors are:

- > High respectively low temperatures
- > Condensed and splash water effects
- > Radiation stress
- > High vibration stress
- > Use in vacuum and/or clean rooms
- > Exposure to special media (e.g. fumes, acids, etc.)
- > High accelerations and velocity
- > Continuous, short stroke movements (< 2 x carriage length)
- > Dirt and dust effects

4.2 Lubricants

Lubrication oil, low-viscosity or other greases can be selected for the lubrication of linear guide systems.

Function of the lubricant:

- > Reduction of the friction
- > Reduction of the start-up moment
- > Protection against premature wear
- > Corrosion protection
- > Noise reduction

Attention !

Lubricants with solid additives such as graphite PTFE or MoS₂ are not suitable for the lubrication of linear guide systems.

NTN-SNR provides a range of high-performance lubricants for different environmental conditions and influencing factors. Information about the lubricant are contained in the Chapters 4.2.2 up to 4.2.4.

4.2.1 Anti-corrosion oils

Anti-corrosion oils are used to protect the linear guides against corrosion during storage and transport. Anti-corrosion oils are not suitable for lubricating linear guides during operation. Compatibility with the planned lubricant must always be checked before relubrication and initial operation.

NTN-SNR linear guides are delivered with the anti-corrosion oil “Contrakor Fluid H1”. “Contrakor Fluid H1” is compatible with the NTN-SNR standard lubricant. Preservation may be omitted by agreement for special applications with special lubricants.

4.2.2 Lubrication oils

Oil lubrication is usually applied in central lubrication systems. The advantage of an automated, central oil lubrication is that of operator-independent, continuous lubricant supply to all lubrication points. Lubrication oils also conduct friction heat very well. This is balanced against a very high construction and installation effort for lubrication lines. Lubrication oil also leaks more often from the carriage and is thus lost to the system. To ensure that all race ways of a linear guide supplied with sufficient lubricant, it is necessary for oil lubrication to adapt the lubrication channels in the end plates to the mounting position. The installation positions are to be defined according to the information in Chapter 3.4. Appropriate lubrication oils for use in NTN-SNR linear guides are summarised in Table 4.1.

Table 4.1 Lubrication oils

Description	Oil type	Kinematic viscosity according to DIN51562 at 40°C [mm²/s]	Density [mg/cm³]	Properties	Application area
Klüberoil GEM 1-100N	Mineral oil	100	880	Good corrosion and wear protection	• General machine building
Klüberoil 4 UH1-68N	Polyalphaolefin	680	860	good ageing and wear protection, NSF H1 registered*	• Foodprocessing industry • Pharmaceutical industry

* This lubricant has been registered as an H1 product, i.e. it was developed for occasional, technically unavoidable contact with food. Experience has shown that the lubricant can also be used for appropriate applications in the pharmaceutical and cosmetic industry when the conditions in the product information are adhered to. However, no specific test results that might be required for applications in the pharmaceutical industry, e.g. bio-compatibility, are available. The systems manufacturer and operator should therefore perform appropriate risk analyses before applications in this area. Measures to exclude health risks and injuries have to be taken, where required. (Source: Klüber Lubrication)

4.2.3 Low-viscosity greases

The conditions that apply to the use of lubrication oils also apply to the use of low-viscosity greases. However, it is not necessary to define the installation position, as low-viscosity greases do not run off easily, due to their viscosity. Appropriate low-viscosity greases for use in NTN-SNR linear guides are summarised in Table 4.2

Table 4.2 Low-viscosity greases

Description	Base oil / Type of soap	NLGI-class DIN51818	Worked penetration DIN ISO 2137 at 25°C [0,1mm]	Basic oil viscosity DIN 51562 at 40°C [mm ² /s]	Density [g/cm ³]	Properties	Application area
Isoflex Topas NCA 5051	Synthetic hydrocarbon oil, special calcium soap	0/00	385...415	30	800	Low friction	<ul style="list-style-type: none"> • General machine building
Microlub GB 0	Mineral oil	0	355...385	400	900	Good wearing Protection, Particularly pressure resistant	<ul style="list-style-type: none"> • General machine building • High loads • Short-stroke • Applications • Vibrations
Klübersynth UH1 14-1600	Synthetic hydrocarbon oil, special Aluminum-complex soap	0/00	370...430	ca. 160	850	Good ageing and Wear protection, NSF H1 registered*	<ul style="list-style-type: none"> • Food processing industry • Pharmaceutical industry

* This lubricant has been registered as an H1 product, i.e. it was developed for occasional, technically unavoidable contact with food. Experience has shown that the lubricant can also be used for appropriate applications in the pharmaceutical and cosmetic industry when the conditions in the product information are adhered to. However, no specific test results that might be required for applications in the pharmaceutical industry, e.g. bio-compatibility, are available. The systems manufacturer and operator should therefore perform appropriate risk analyses before applications in this area. Measures to exclude health risks and injuries have to be taken, where required. (Source: Klüber Lubrication)

4.2.4 Lubrication greases

Most applications are based on linear guides with grease lubrication. The use of greases provides better noise reduction and also better emergency running properties and requires less constructive effort than lubrication oils and low-viscosity greases. Lithium soap greases with the Classification KP2-K according to DIN 51825 and NLGI Class 2 according to DIN 51818 with EP additives are to be used for applications under normal conditions. Suitable lubricants must be selected for specific applications under special environmental conditions. It must always be checked whether the different lubricants used are compatible with each other or with the preservation agent.

Table 4.3 contains an overview of the lubricants used in NTR-SNR linear guides.

Table 4.3 Greases

Description	Base oil / Type of soap	NLGI-classe DIN51818	Worked penetration DIN ISO 2137 at 25°C [0,1mm]	Basic oil viscosity DIN 51562 at 40°C [mm²/s]	Density [mg/cm³]	Propertie	Application area
SNR LUB HEAVY DUTY	Mineral oil / Lithium with EP additives	2	295	ca. 115	890	Very high protection against wear and corrosion	<ul style="list-style-type: none"> • High temperature range • High loads
SNR LUB HIGH SPEED+	Esther, SHC / Lithium, Calcium	2	-	25	900	Very good adhesion properties, Very good water resistance	<ul style="list-style-type: none"> • High velocity
SNR LUB HIGH TEMP	semi-synthetic oil / Polyurea	2	265...295	160	900	High temperature resistance, Good corrosion protection, High oxidation resistance	<ul style="list-style-type: none"> • High temperature range
SNR LUB FOOD	Paraffinic mineral oil, PAO / Aluminum complex	2	265...295	195	920	Good corrosion protection, Very good adhesion properties, High water resistance, NSF H1 registered*	<ul style="list-style-type: none"> • Food processing industry
Microlub GL261	Mineral oil / special lithium-calcium soap	1	310...340	280	890	Good wearing protection, Particularly pressure-resistant, Additive against tribocorrosion	<ul style="list-style-type: none"> • High temperature range • High loads • Short-stroke application • Vibrations
Klübersynth BEM34-32	Synthetic hydrocarbon oil / special calcium soap	2	265...295	ca. 30	890	Particularly pressure-resistant, Good wearing protection, Good ageing resistance, Low starting torque	<ul style="list-style-type: none"> • Clean room application
Klübersynth UH1 14-151	Synthetic hydrocarbon oil / ester oil Aluminum complex soap	1	310...340	ca.150	920	Good corrosion protection, Good ageing resistance, High water resistance, NSF H1 registered*	<ul style="list-style-type: none"> • Food processing industry • Pharmaceutical industry

* This lubricant has been registered as an H1 product, i.e. it was developed for occasional, technically unavoidable contact with food. Experience has shown that the lubricant can also be used for appropriate applications in the pharmaceutical and cosmetic industry when the conditions in the product information are adhered to. However, no specific test results that might be required for applications in the pharmaceutical industry, e.g. bio-compatibility, are available. The systems manufacturer and operator should therefore perform appropriate risk analyses before applications in this area. Measures to exclude health risks and injuries have to be taken, where required. (Source: Klüber Lubrication)

4.3. Lubrication methods

NTN-SNR linear can be supplied with lubricant by manual grease guns (Figure 4.1), automated lubricant dispensers (Figure 4.2) or central lubrication systems (Figure 4.3). The carriages are relubricated through the installed grease nipple (Chapter 4.4.1) when manual grease guns (Chapter 4.4.4) are used.

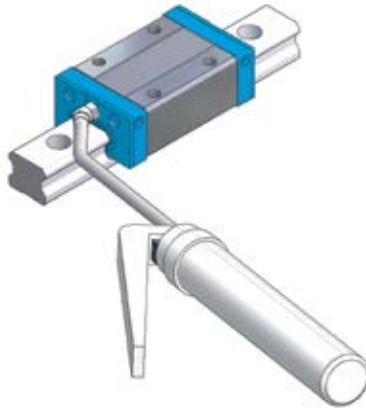


Figure 4.1 Lubrication with manual grease gun

Automated lubricant dispensers (Figure 4.2) ensure the supply of the carriages with lubricant for a definable period. The lubricant dispensers can be connected by a hose to the installed lubrication adaptors (see Chapter 4.4.2), depending on the space available. Care should be taken that each lubrication point has a separate lubrication dispenser and that a maximum pipe length of 500 mm is not exceeded.



Experts & Tools **NTN SNR**

Figure 4.2 Automated lubricant dispenser

Central lubrication systems can be manually operated or automatically controlled. Manual central lubrication systems have a pump that is operated with a manual lever and supplies all lubrication points with lubricant. Automated central lubrication systems ensure a regular supply of all lubrication points with the amount of lubricant required. These systems can also be implemented as oil-spray lubrication systems under special environmental conditions. Oil is nebulised by compressed air and transported to the lubrication points. Oil mist lubrication systems ensure continuous supply of the lubrication points with the minimum amount of lubricant required and optimal conduction of friction heat. The permanent overpressure in the system also prevents the penetration of foreign particles such as dust or cooling lubricant into the carriages.



Experts  & Tools

Figure 4.3 Central lubrication systems

4.4 Accessories

4.4.1 Grease nipples

A range of grease nipple is available for lubrication of profile rail guides with manual grease guns. Table 4.4 contains an overview of the grease nipples used by NTN-SNR.

Table 4.4 Grease nipples

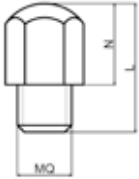




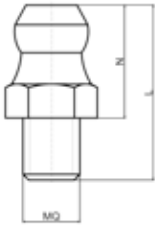



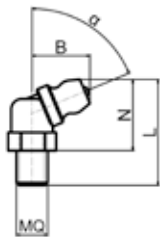



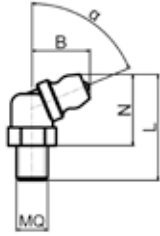







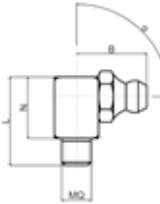






Standard type	Description	MQ	L [mm]	N [mm]	Linear guide	Installation position	Comments
	Grease nipple ball type GRN-M3-3,5-z-0	M3	9,7	4,5	LGM...15B LGM...15W		
	Grease nipple ball type GRN-M3-3,5-z-0	M3	9,5	6	LGB...15		
	Grease nipple ball type GRN-M3-5,0-z-0		13,0	7,0			
	Grease nipple ball type GRN-M3-8,0-z-0		15,0	7,0			For double seals For double seals and scraper
Type	Description	MQ	L [mm]	N [mm]		Linear guide	Installation position
	Grease nipple hydraulic type GRN-M6-5,0-z-0	M6	15,0	9,5	LGB...20,25		
	Grease nipple hydraulic type GRN-M6-8,0-z-0				17,3		9,5
	Grease nipple hydraulic type GRN-M6-12,0-z-0		24,0	10,0	LGB...30,35		For double seals For double seals and scraper
	Grease nipple hydraulic type GRN-M6-8,0-z-0	M8			18,2	10,2	LGB...20, 25
	Grease nipple hydraulic type GRN-M6-12,0-z-0		22,2	LGB...45,55			

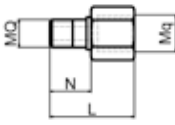






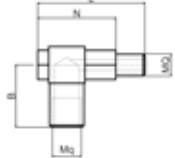

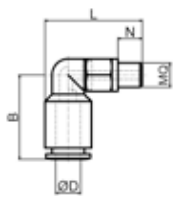








Table 4.4 Grease nipples

Type	Description	MQ	α [°]	L [mm]	N [mm]	B [mm]	Linear guide	Installation position	Comments
	Grease nipple hydraulic type GRN-M6-5,5-k-45	M6	45	23,5	18,0	10,5	LGB...20...35		
							LGB...20...35		
							LGB...45, 55		For double seals in combination with extention LE-M6-M6 For double seals and scraper in combination with extention LE-M8-M6
Standard type	Description	MQ	α [°]	L [mm]	N [mm]	B [mm]	Linear guide	Installation position	Comments
	Grease nipple hydraulic type GRN-M6-5,0-z-67	M6	67,5	18,5	13,5	11,4	LGB...20, 25		
	Grease nipple hydraulic type GRN-M6-8,0-z-67			21,5			LGB...20...35		For LGB...20, 25 also For double seals
	Grease nipple hydraulic type GRN-M6-12,0-z-67			25,5			LGB...30, 35		
	Grease nipple hydraulic type GRN-M6-12,0-z-67		LGB...20...35		For double seals and scraper				
	Grease nipple hydraulic type GRN-M6-12,0-z-67		LGB...30, 35		For double seals				
	Grease nipple hydraulic type GRN-M8-8,0-z-67	M8	67,5	21,3	13,3	12,3	LGB...45, 55		
Grease nipple hydraulic type GRN-M8-12,0-z-67	25,3						For double seals For double seals and scraper		
Type	Description	MQ	α [°]	L [mm]	N [mm]	B [mm]	Linear guide	Installation position	Comments
	Grease nipple hydraulic type GRN-M6-5,5-k-90	M6	90	18,0	12,5	13,0	LGB...20, 25		
	Grease nipple hydraulic type GRN-M6-7,5-z-90			20,0			LGB...30, 35		
	Grease nipple hydraulic type GRN-M6-12,0-z-90			24,5			LGB...20...35		For LGB...20, 25 also For double seals
	Grease nipple hydraulic type GRN-M6-12,0-z-90		LGB...20...35		For double seals and scraper				
	Grease nipple hydraulic type GRN-M6-12,0-z-90		LGB...30, 35		For double seals				
	Grease nipple hydraulic type GRN-M8-8,0-z-90	M8	90	20,5	12,5	13,0	LGB...45, 55		
Grease nipple hydraulic type GRN-M8-12,0-z-90	24,5			LGB...45, 55				For double seals For double seals and scraper	

4.4.2 Lubrication connection

The use of central lubrication systems or the arrangement of grease nipples in more accessible positions require a lubricant supply to the carriages via hoses or pipes. For this purpose, Table 4.5 shows lubrication connection that can be mounted on NTN-SNR linear guides.

Table 4.5 Lubrication connection

	Description	N [mm]	L [mm]	MQ	Mq	Linear guides	Installation position	Comments	
	Extension LE-MQ-MqxL	6	15,4	M6	M6 M8 or 1/8"	LGB...20,25			
		9	18,4			LGB...30,35			
		13	22,4			LGB...20...35			
		13	22,4			LGB...20...35		For double-seal For double-seal + scraper	
		9	18,4	LGB...45,55					
		13	22,4				For double-seal For double-seal + scraper		
	Description	N [mm]	L [mm]	B [mm]	MQ	Mq	Linear guides	Installation position	Comments
	Swivel connection LS-MQ-Mq	21,5	29,5	17,0	M6	M6 M8x1	LGB...20...35		Can be used for LGB...45 and 55 in connection with the LE-M8-M6 extension
	Description	N [mm]	L [mm]	B [mm]	MQ	Ø D [mm]	Linear guides	Installation position	Comments
	Tube connection LH-M6S-ØD	4,0	16	16	M6	4 or 6	LGB...20...35		
							LGB...20...35		Can be used in connection with Extension LE-M6-M6
							LGB...45,55		Can be used in connection with Extension LE-M8-M6
	Description	N [mm]	L [mm]	MQ	Ø D [mm]	Linear guides	Installation position	Comments	
	Tube connection LH-M3A-ÆD	11,5	14,5	M3	3	LGB...15			
	Tube connection LH-M6A-ØD	14,0	18,0	M6	4 or 6	LGB...20...35			
						LGB...20...35		Can be used in connection with Extension LE-M6-M6	
						LGB...45,55		Can be used in connection with Extension LE-M8-M6	

4.4.3 Lubrication adapter

The carriage of NTN-SNR linear guides are also prepared for the lubrication from the top of the end caps. For this purpose, the marked lubrication hole in the lowering must be opened. For this re-lubrication version are O - rings and adapters for height adjustment necessary. In table 4.6 are the necessary lubrication adapter and O - rings shown.

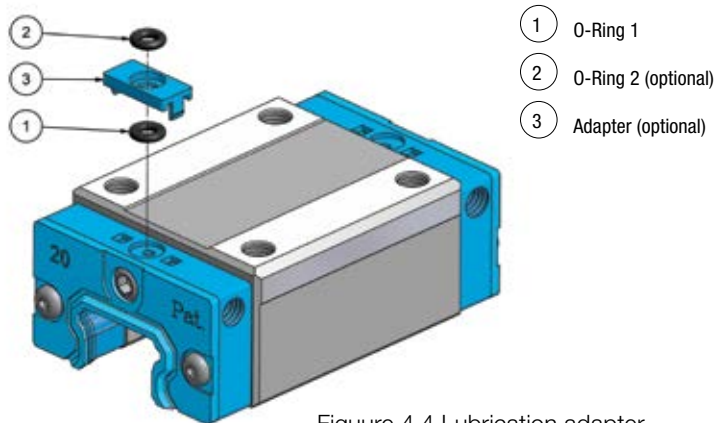


Figure 4.4 Lubrication adapter

Tabelle 4.6 Lubrication adapter

Series	Design version	Size	Lubrication adapter	O-Ring (1)	O-Ring (2)
LGB_H	F	15	--	ORI3X1NBR70	--
		20	LA-02	ORI3X1,5NBR70	ORI3X1,5NBR70
		25	LA-03	ORI5X1,5NBR70	ORI3X1,5NBR70
		30	--	ORI6X1,5NBR70	--
		35	--	ORI6X1,5NBR70	--
		45	--	ORI10x2NBR70	--
	B	15	LA-04	ORI3X1NBR70	ORI3X1NBR70
		20	LA-02	ORI3X1,5NBR70	ORI3X1,5NBR70
		25	LA-07	ORI5X1,5NBR70	ORI3X1,5NBR70
		30	LA-03	ORI6X1,5NBR70	ORI3X1,5NBR70
		35	LA-07	ORI6X1,5NBR70	ORI3X1,5NBR70
		45	LA-10	ORI10x2NBR70	ORI10x2NBR70
LGB_X	B	25	LA-03	ORI5X1,5NBR70	ORI3X1,5NBR70
LGB_S	F	15	--	ORI3X1NBR70	--
		20	--	ORI3X1,5NBR70	--
		25	--	ORI5X1,5NBR70	--
	B	15	--	ORI3X1NBR70	--
		20	--	ORI3X1,5NBR70	--
		25	--	ORI5X1,5NBR70	--
		30	--	ORI6X1,5NBR70	--
		35	--	ORI6X1,5NBR70	--
		45	--	ORI10x2NBR70	--
		55	--	ORI10x2NBR70	--

4.4.4 Grease guns

Manual relubrication of linear guides can be performed with NTN-SNR grease guns

Technical data:

- > Weight: 1 130 g
- > Operating pressure: 180 bar
- > Maximum pressure: 360 bar
- > Transported volume: 0,8 cm³ / stroke
- > Suitable for 400 g cartridges and can also be filled with loose grease
- > Various adapter available



Figure 4.5 NTN-SNR grease press

4.4.5 Automated lubricant dispenser

Automated lubricant dispensers supplied by NTN-SNR are available with different oil or grease types. The lubricant is transported with a maximum pressure of 6 bar. Automated lubricant dispensers are intended for operation in a temperature range from -20°C to +60°C in all operating positions. The automated lubricant dispenser are available in the IP 65. Our NTN-SNR application engineers will gladly provide you with more information.

4.5 Lubricant volumes

Maintenance of linear guides may involve:

- > Initial lubrication
- > Lubrication during initial operation
- > Re-lubrication

The respective minimum lubricant amounts are defined as a function of the type and design size of the linear guide. NTN-SNR linear guides are initially lubricated with lithium soap grease KP2-K according to DIN 51825 and NGLI Class 2 at the time of delivery. We recommend to lubricate the carriages again for the initial operation. Table 4.7 shows the minimum amounts of lubrication that have to be provided to NTN-SNR linear guides for initial lubrication and lubrication for initial operation.

Table 4.7 Minimum amounts of lubricant for initial lubrication and lubrication for initial operation

Size	Carriage type	Grease lubrication [cm³]	Low-viscosity grease lubrication [ml]	Oil lubrication [ml]
LGB_15	FS, BS	0,7	0,2	
	BN, FN	0,9	0,2	
	BL, FL	1,0	0,2	
	BE, FE	1,1	0,2	
LGB_20	FS, BS	1,1	0,3	
	BN, FN	1,5	0,4	
	BL, FL	1,8	0,4	
	BE, FE	2,0	0,5	
LGB_25	FS, BS	1,6	0,4	
	BN, FN	2,3	0,5	
	BL, FL	2,6	0,6	
	BE, FE	3,1	0,7	
LGB_30	FS, BS	2,8	0,7	
	BN, FN	3,7	0,9	
	BL, FL	4,0	1,0	
	BE, FE	5,0	1,2	
LGB_35	FS, BS	3,9	0,9	
	BN, FN	5,7	1,4	
	BL, FL	6,3	1,5	
	BE, FE	7,5	1,8	
LGB_45	BN, FN	7,0	2,0	
	BL, FL	9,0	2,3	
	BE, FE	10,0	2,8	
LGB_55	BN, FN	13,0	3,5	
	BL, FL	17,0	4,5	
	BE, FE	19,0	5,5	
LGM_07	BN	0,01	--	
LGM_09	BN	0,03	--	
	BL	0,05	--	
	WN	0,04	--	
	WL	0,05	--	
LGM_12	BN	0,05	--	
	BL	0,08	--	
	WN	0,05	--	
	WL	0,10	--	
LGM_15	BN	0,10	--	
	BL	0,15	--	
	WN	0,10	--	
	WL	0,15	--	

The demand of lubricant is during the operation lower than during the initial operation. In Tab. 4.7 are the minimal lubricant amount arranged.

Table 4.8 Minimum amounts of lubricant for relubrication

Size	Carriage type	Grease lubrication [cm ³]	Low-viscosity grease lubrication [ml]	Oil lubrication [ml]
LGB_15	FS, BS	0,3	0,1	
	BN, FN	0,4	0,1	
	BL, FL	0,5	0,1	
	BE, FE	0,6	0,2	
LGB_20	FS, BS	0,8	0,1	
	BN, FN	1,2	0,2	
	BL, FL	1,4	0,2	
	BE, FE	1,6	0,3	
LGB_25	FS, BS	0,8	0,1	
	BN, FN	1,2	0,2	
	BL, FL	1,4	0,2	
	BE, FE	1,7	0,3	
LGB_30	FS, BS	1,4	0,2	
	BN, FN	2,0	0,2	
	BL, FL	2,2	0,3	
	BE, FE	2,8	0,3	
LGB_35	FS, BS	2,0	0,2	
	BN, FN	3,1	0,3	
	BL, FL	3,5	0,3	
	BE, FE	4,1	0,4	
LGB_45	BN, FN	4,0	0,5	
	BL, FL	4,5	0,5	
	BE, FE	5,0	0,6	
LGB_55	BN, FN	6,0	0,6	
	BL, FL	8,0	0,6	
	BE, FE	9,0	0,7	
LGM_07	BN	0,005		
LGM_09	BN	0,015	--	
	BL	0,025	--	
	WN	0,020	--	
	WL	0,025	--	
LGM_12	BN	0,025	--	
	BL	0,040	--	
	WN	0,025	--	
	WL	0,050	--	
LGM_15	BN	0,050	--	
	BL	0,075	--	
	WN	0,050	--	
	WL	0,075	--	

4.6 Lubrication intervals

Delivery condition

The NTN-SNR carriages of all series are already provided with initial lubrication at the time of delivery. The carriages should be lubricated after mounting with the grease amount from Table 4.7 in 2-3 steps with intermediate movement over a longer stroke for the optimal grease distribution in the system.

The carriages also require initial lubrication before a prolonged shut-down and before re-operation.

The mixing compatibility of the lubricants must be checked when the lubricant make is to be changed during operation of a system.

Influence factors

The relubrication intervals are affected by several factors (Chapter 4.1). Load and pollution usually have the strongest effect. Accurate relubrication intervals for a specific system can only be determined after the actual operating conditions have been assessed for a sufficiently long period.

Lubrication interval for oil lubrication

The reference value for adjusting central oil lubrication systems is one lubrication pulse per carriage every 20 minutes, using the amount of lubricant specified in Table 4.8. Central lubrication systems with low-viscosity grease should be set to a lubrication interval of 60 minutes.

Lubrication interval for conventional linear guides and grease lubrication

The reference value for relubrication with grease for conventional guide systems (LGBX, LGMX series) under normal operating conditions is every six months or after 100 km travel distance. This value can be adjusted upwards or downwards under special environmental conditions. The lubrication interval should not be longer than 2 years or 500 km travel distance, even under optimal environmental conditions, without pollution and low load. The amounts specified in Table 4.8 should be used for relubrication.

Lubrication interval for linear guides with ball chain and grease lubrication

These values significantly improve for the same conditions when guiding systems with integrated ball chain (LGBG, LGMC series) are used. The reference value for NTN-SNR linear guides with ball chains under normal operating conditions is lubrication once per year or after 500 km of travel distance. This value may have to be adjusted upwards or downwards under special environmental conditions. A travel performance of several thousand kilometres between maintenance steps is possible when the environmental conditions are good and the load is low. The maximum usage time of the lubricant must be considered when the lubrication cycles are very long.

Our NTN-SNR application engineers will gladly help you to determine the maintenance intervals.

5. Accessories

5.1 Sealing Options

5.1.1 Description

Linear guides are exposed to a variety of pollution types during operation. Pollution can be caused by solid or liquid foreign particles. The purpose of the sealing system is:

- > To prevent penetration of foreign particles of any kind
- > To distribute the lubricant evenly over the tracks
- > To minimise the loss of lubricant

NTN-SNR linear guides can be combined with a multitude of sealing options to provide an optimal sealing system for various applications. The following sealing elements are available for these combinations:

End seal* ①

- Two lip seal
- Rubber - metal - part
- Front seal of the carriage against contamination from outside
- Minimization of lubricant loss
- Sealing for normal environmental conditions

Inner seal* ②

- Two lip seal
- Sealing of the carriage's inside against the entry of contamination by deposits in the rail holes
- Reduction of the volume in which the lubricant can be distributed
- Minimization of lubricant loss
- Sealing for all environmental conditions

Side seal* ③

- Two lip seal
- Sealing of the carriage's inside against the entry of contamination from below
- Minimization of lubricant loss
- Sealing for all environmental conditions, especially in vertical and overhead position

Multi - Layer - Seal MLS ④

- Sealing element of several oil-impregnated laminate layers
- Sealing in case of extreme heavy contamination
- Useful application in combination with double seals or double seals and scraper

Double seal ⑤

- Combination from two end seals and spacer element
- Sealing in case of very heavy contamination
- Additional mounting of scrapers possible

Scraper ⑥

- Metal scraper
- Scrapers have no contact with the rail
- Sealing against heavy dirt and chips
- Not suitable as single sealing

Low friction seal LFS

- One lip seal
- Reduction of the seal resistance
- Use under conditions with low contamination possible

* Standard ssealing (miniature guides without inner seal)

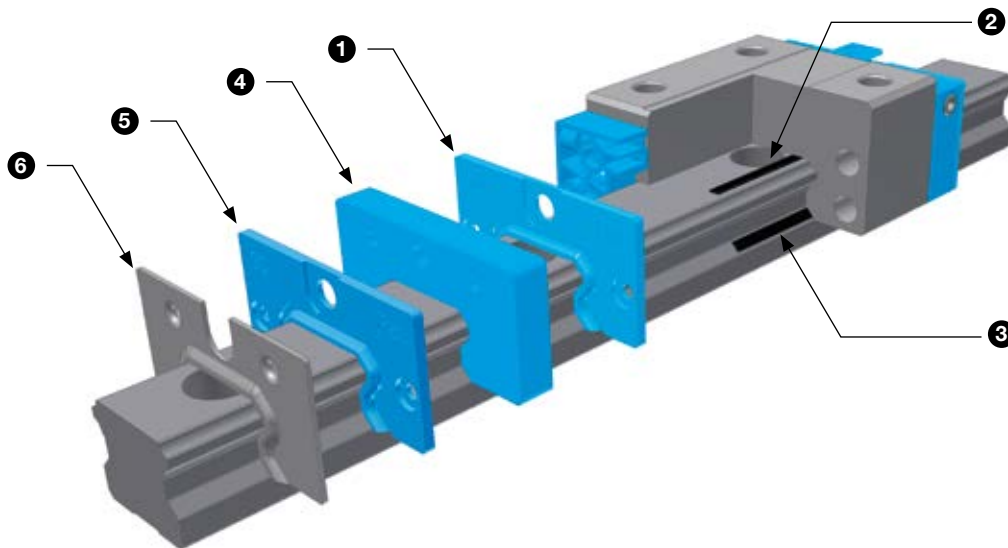
5.1.2 Combination options

Table 5.1 provides a summary of the various sealing options for NTN-SNR- linear guide

Table 5.1 Sealing options

Description	LGB	LGM	Sealing structure
SS	S	-	End seals on both sides, inner and side seals
AA	X	X	No sealing
UU	X	-	End seals on both sides
BB	X	S	End seals on both sides and side seals
EE	X	-	Double end seals on both sides, inner and side seals
FF	X	-	End seals on both sides, inner and side seals, scraper on both sides
GG	X	-	Double end seals on both sides, inner and side seals, scraper on both sides
ES	X	-	Double end seals on one side, inner and side seals
FS	X	-	End seals on both sides, inner and side seals, scraper on one side
GS	X	-	Double end seals on one side, inner and side seals, scraper on one side
VV	X	-	Double end seals on both sides, inner and side seals, MLS on both sides
WW	X	-	Double end seals on both sides, inner and side seals, scraper and MLS on both sides
LL	X	-	LFS on both sides
JJ	X	-	LFS on both sides and side seals
XX	X	-	Special sealing option (description of customer specification required)

- S Standard sealing
- X Sealing option available
- Sealing option not available



5.1.3 Dimensions

The length L of the carriage varies according to the selected sealing option. The respective lengths are summarised in Table 5.2.

Table 5.2 Carriage length with sealing options [mm]

Size	SS	UU	AA	BB	EE	FF	GG	VV	WW	LL	JJ
LGB_15_S	40,6	40,6	40,6	40,6	46,6	42,4	48,4	59,6	61,4	40,6	40,6
LGB_15_N	58,6	58,6	58,6	58,6	64,6	59,5	66,4	77,6	79,4	58,6	58,6
LGB_15_L	66,1	66,1	66,1	66,1	72,1	67,0	73,9	85,1	86,9	66,1	66,1
LGB_15_E	81,1	81,1	81,1	81,1	87,1	82,0	88,9	100,1	101,9	81,1	81,1
LGB_20_S	48,3	48,3	48,3	48,3	55,3	49,5	57,7	68,3	70,7	48,3	48,3
LGB_20_N	69,3	69,3	69,3	69,3	76,3	70,5	78,7	89,3	91,7	69,3	69,3
LGB_20_L	82,1	82,1	82,1	82,1	89,1	83,3	91,5	102,1	104,5	82,1	82,1
LGB_20_E	97,3	97,3	97,3	97,3	104,3	98,5	106,7	117,3	119,7	97,3	97,3
LGB_25_S	54,0	54,0	54,0	54,0	61,0	55,5	63,9	74,0	76,9	54,0	54,0
LGB_25_N	79,2	79,2	79,2	79,2	85,7	80,2	88,6	98,7	101,6	79,2	79,2
LGB_25_L	93,9	93,9	93,9	93,9	100,4	94,9	103,3	113,4	116,3	93,9	93,9
LGB_25_E	108,6	108,6	108,6	108,6	115,1	109,6	118,0	128,1	131,0	108,6	108,6
LGB_30_S	64,2	64,2	64,2	64,2	72,2	65,5	74,8	90,2	92,8	64,2	64,2
LGB_30_N	94,8	94,8	94,8	94,8	102,8	96,1	105,4	120,8	123,4	94,8	94,8
LGB_30_L	105,0	105,0	105,0	105,0	113,0	106,3	115,6	131,0	133,6	105,0	105,0
LGB_30_E	130,5	130,5	130,5	130,5	138,5	131,8	141,1	156,5	159,1	130,5	130,5
LGB_35_S	75,5	75,5	75,5	75,5	85,5	76,8	88,1	103,5	106,1	75,5	75,5
LGB_35_N	111,5	111,5	111,5	111,5	121,5	112,8	124,1	139,5	142,1	111,5	111,5
LGB_35_L	123,5	123,5	123,5	123,5	133,5	124,8	136,1	151,5	154,1	123,5	123,5
LGB_35_E	153,5	153,5	153,5	153,5	163,5	154,8	166,1	181,5	184,1	153,5	153,5
LGB_45_N	129,0	129,0	129,0	129,0	139,0	130,5	142,0	157,0	160,0	129,0	129,0
LGB_45_L	145,0	145,0	145,0	145,0	155,0	146,5	158,0	173,0	176,0	145,0	145,0
LGB_45_E	174,0	174,0	174,0	174,0	184,0	175,5	187,0	202,0	205,0	174,0	174,0
LGB_55_N	155,0	155,0	155,0	155,0	165,0	156,3	167,6	183,0	185,6	155,0	155,0
LGB_55_L	193,0	193,0	193,0	193,0	203,0	194,3	205,6	221,0	223,6	193,0	193,0
LGB_55_E	210,0	210,0	210,0	210,0	220,0	211,3	222,6	238,0	240,6	210,0	210,0
LGM_07BN	--	--	24,0	24,0	--	--	--	--	--	--	--
LGM_09BN	--	--	30,8	30,8	--	--	--	--	--	--	--
LGM_09BL	--	--	40,5	40,5	--	--	--	--	--	--	--
LGM_12BN	--	--	34,0	34	--	--	--	--	--	--	--
LGM_12BL	--	--	47,0	47	--	--	--	--	--	--	--
LGM_15BN	--	--	42,0	42	--	--	--	--	--	--	--
LGM_15BL	--	--	59,8	59,8	--	--	--	--	--	--	--
LGM_09WN	--	--	39,0	39	--	--	--	--	--	--	--
LGM_09WL	--	--	51,0	51	--	--	--	--	--	--	--
LGM_12WN	--	--	44,5	44,5	--	--	--	--	--	--	--
LGM_12WL	--	--	59,1	59,1	--	--	--	--	--	--	--
LGM_15WN	--	--	55,5	55,5	--	--	--	--	--	--	--
LGM_15WL	--	--	74,7	74,7	--	--	--	--	--	--	--

5.2 Rail caps

Foreign particles may reach the inside of the carriage through the fastening holes in the guide rail and cause damage. We recommend that you close the holes in the rail with rail caps to prevent this. These caps consist of oil-resistant plastic. Rail caps made of brass may be used when the pollution is very strong or when direct mechanical forces act on the guide rails. Table 5.3 contains an overview of the rail caps available.

Table 5.3 Rail caps

Size	Rail cap		Dimension [mm]	
	Plastic	Brass	D	H
LGMR09	LG-CAP1	--	6,0	1,5
LGMR12	LG-CAP1	--	6,0	1,5
LGMR15	LG-CAP1	--	6,0	1,5
LGMW09	LG-CAP1	--	6,0	1,5
LGMW12	LG-CAP2	--	8,0	2,0
LGMW15	LG-CAP2	--	8,0	2,0
LGBR15	LG-CAP4	LG-CAP4B	7,5	1,3
LGBR20	LG-CAP5	LG-CAP5B	9,5	2,5
LGBR25	LG-CAP6	LG-CAP6B	11,0	2,5
LGBR30	LG-CAP8	LG-CAP8B	14,0	3,5
LGBR35	LG-CAP8	LG-CAP8B	14,0	3,5
LGBR45	LG-CAP12	LG-CAP12B	20,0	3,5
LGBR55	LG-CAP14	LG-CAP14B	23,0	4,5

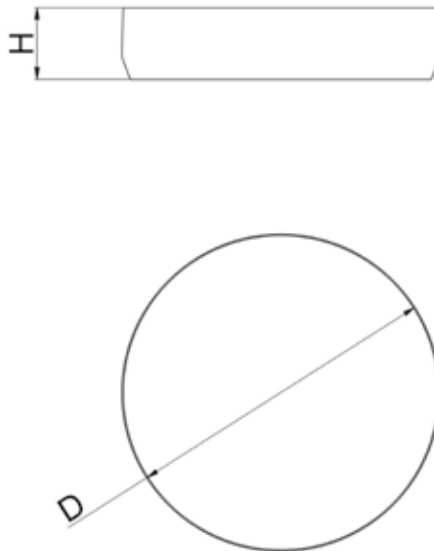


Figure 5.2 Rail caps

5.3 Bellows

If linear guides exposed to strong contamination by chips, dust or welding spatter, it is recommended to protect the guides by special bellows. For NTN-SNR linear guides are the corresponding bellows available. The corresponding mounting sets can be used for the fixing of the bellows. The mounting sets consist of all necessary mounting screws, a distance element and a clamping element. With the clamping elements, the bellows are positioned and fixed on the rail. A special manufacturing of the rail is not necessary.

5.3.1 Dimensions

Table 5.4 Bellows

Size	Height [mm] A	Width [mm] B	Overall height [mm] A1	Depth of fold [mm] Ft	Relation of length R	Length per fold [mm] ApF	Stroke per fold [mm] HpF	Thick-ness mountig set [mm]	Recom- mended design typ of carriage	Type bellow
15	26	46	29	15	8	20	17,5	5	LGB_H15F	LGB15-BEL-H...
20	32,5	61	37	20	10	30	27	5	LGB_H20F	LGB20-BEL-H...
25	33,5	66	39,5	20	10	30	27	5	LGB_H25F	LGB25-BEL-H...
30	37	70	44	20	10	30	27	6	LGB_H30F	LGB30-BEL-H...
35	39,5	78	47	20	10	30	27	6	LGB_H35F	LGB35-BEL-H...
45	44	85	53	20	10	30	27	8	all	LGB45-BEL-H...
55	50	97	62,5	20	10	30	27	8	all	LGB55-BEL-H...

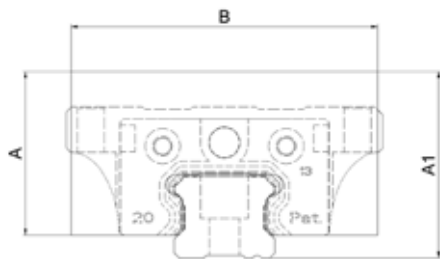
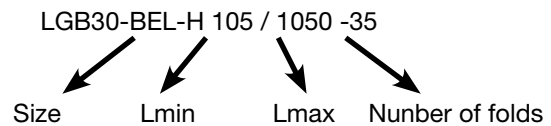


Figure 5.3 Dimensions of the bellows

Calculation of the bellow length:

Necessary quantity = Number of folds = Round up (Stroke / HpF) + 1 or Round off (Lmax / ApF) + 1
 Lmin = Number of folds * 3mm (2,5 mm for size 15)

Type code bellow:



Type code Mounting set:

LGB30-BEL-H-MS

5.3.2 Assembly of bellows

- Move the carriage (pos.2) to the rail end and disassemble the bottom head screws (pos.8) of the end seals.
- Assemble bellow (pos.5) with the spacer (pos.3) and the enclosed bottom head screws (pos.8) on the carriage.
- Assemble bellow on the clamping element (pos.4) with the bottom head screws (pos.7).
- Position of the bellow with the assembled clamping element at the desired location.
- Fix of the clamping element with the set screw (pos.6) on the rail.

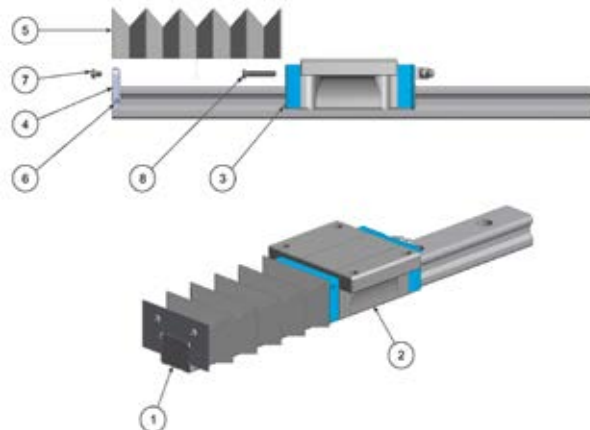


Figure 5.4 Assembly of bellows

5.3.3 Designation

The bellows for NTN-SNR linear guides and the related parts have the following designations:

- Bellow LGB[size] - BEL-H Lmin / Lmax - Number of folds
- Mounting set LGB[size] - BEL-H- MS

5.4 Cover strip

To close the rail holes, NTN-SNR linear guides can be assembled with a cover strip. In this case, the assembly time which is required to close the holes from long rails with plastic caps should be reduced considerably. The cover strip is a stainless steel strip, which is glued on top of the rails. Even under the most adverse environmental conditions, the adhesive bond is not affected. To secure the cover strip on the rail ends, corresponding securing elements are available. The standard cover strip is available in lengths up to 25 m.

5.4.1 Dimension

Table 5.5 Cover strip

Size	Width [mm]	Thickness [mm]	Length of safety element [mm]
LGB15	10	0,3	12,5
LGB20	11	0,3	12,5
LGB25	13	0,3	12,5
LGB30	16	0,3	12,5
LGB35	18	0,3	14,2
LGB45	27	0,3	17,5
LGB55	29	0,3	17,5

5.4.2 Mounting tool

A mounting tool is available for the assembly of the cover strip. The use of the mounting tool ensures a simple, safe and centered mounting on top of rail.

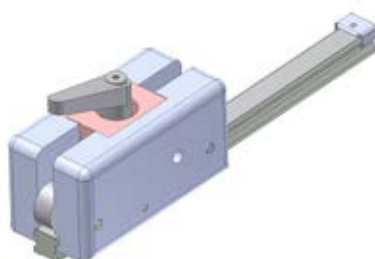


Figure 5.5 Mounting tool

5.4.3 Designation

The cover strip for NTN-SNR linear guides and the related parts have the following designations:

- Cover strip LGB[size]-CS[length in mm (five digits)]
- Safety element LGB[size]-SE
- Mounting tool LGB[size]-MT

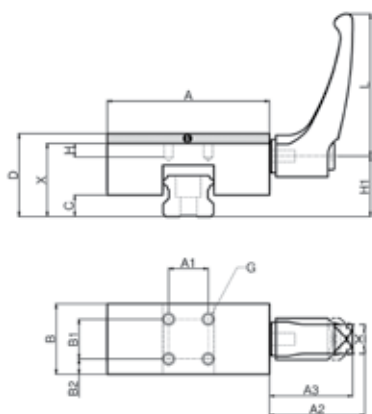
5.5 Clamping- and Braking Elements

Clamping and braking elements for NTN-SNR linear guides allow the positioning, holding and braking in different application areas.

5.5.1 Manual clamping element

5.5.1.1 Manual clamping element for standard guides

The clamping elements of the HK-series are operating manually. By rotating the freely adjustable clamp lever, the contact sections are pressed synchronously against the free surfaces of the section rail guide. The floating contact sections guarantee symmetric power transmission.



NOTE: Consider measurement C/Interfering contour
 ① Adapting plate (accessories)
 X = measure of function to be complied
 D = Linear guide installation measurement (if necessary with adapting plate)

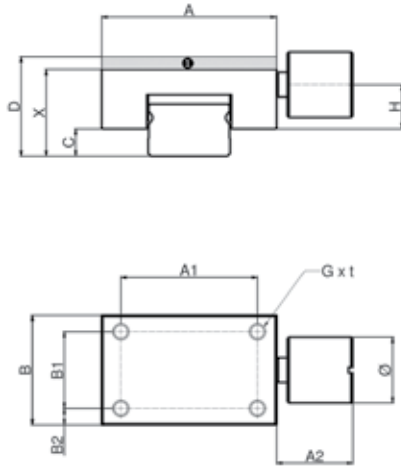
Figure 5.6

Table 5.6 Manual clamping elements for standard guides

Size	Carriage type	Clamping element	Adapter plate	Holding power [N]	Fastening torque [Nm]	Measure [mm]											Mass [kg]			
						A	A1	A2	A3	B	B1	B2	C	D	X	G		L	H	H1
15	LGB_S15B	HK1501A	PHK15-2	1 200	5,0	47	17	33,5	30,5	25	17	4,0	4,5	24	22	M 4	44	5	12,5	0,168
	LGB_S15F													PHK15-6						
	LGB_H15F		--																	
	LGB_H15B													30						
20	LGB_S20B	HK2001A	PHK20-2	1 200	7,0	60	15	41,5	38,5	24	15	4,5	8,0	28	28	M 5	63	6	13,0	0,220
	LGB_S20F													--						
	LGB_H20F		PHK25-3																	
	LGB_H20B													40						
25	LGB_S25B	HK2501A	PHK25-3	1 200	7,0	70	20	41,5	38,5	30	20	5,0	9,0	33	33	M 6	63	8	15,0	0,360
	LGB_S25F													PHK25-7						
	LGB_H25F		--																	
	LGB_X20B													45						
30	LGB_S30B	HK3001A	PHK30-3	2 000	15,0	90	22	50,5	46,5	39	22	8,5	12,0	42	42	M 6	78	8	21,5	0,893
	LGB_H30F													--						
	LGB_H30B		48																	
35	LGB_S35B	H3501A	PMK35-4	2 000	15,0	100	24	50,5	46,5	39	24	7,5	12,0	55	44	M 8	78	10	21,5	1,011
	LGB_H35F													PMK35-11						
	LGB_H35B		55																	
45	LGB_S45B	HK4501A	PHK45-6	2 000	15,0	120	26	50,5	46,5	44	26	9,0	12,0	60	54	M 10	78	14	26,5	1,658
	LGB_H45F													PHK45-16						
	LGB_H45B		70																	
55	LGB_S55B	HK5501A	PHK55-4	2 000	17,0	140	30	61,5	56,5	49	30	9,5	17,0	70	66	M 14	95	16	31,0	1,630
	LGB_H55F													PHK55-14						
	LGB_H55B		80																	

5.5.1.2 Manual clamping element for miniature guides

The clamping elements of the miniHK-series are operating manually. By tightening the clamping screw, the contact sections are pressed synchronously against the free surfaces of the selected linear guide. The floating contact sections guarantee symmetric power transmission.



NOTE: Consider measurement C/Interfering contour
 ① Adapting plate (accessories)

Figure 5.7

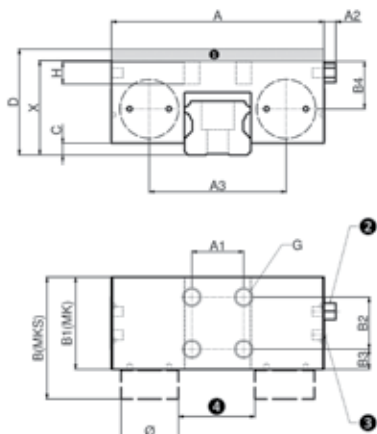
Table 5.7 Manual clamping elements for miniature guides

Size	Carriage type	Clamping element	Adapter plate	Holding power [N]	Fastening torque [Nm]	Measure [mm]											Mass [kg]	
						A	A1	A2	B	B1	B2	C	D	X	G x t	Ø		H
09	LGM_09B	HK0900M	--	100	0,17	20	15	9,0	17	11	3,0	2,7	10	10	M 3 x 3	8	5,35	0,016
	LGM_09W	HK0900MW	--	100	0,17	30	17	9,0	17	11	3,0	4,2	12	12	M 3 x 3	8	5,85	0,031
12	LGM_12B	HK1200M	--	150	0,35	27	20	10,0	19	13	3,0	3,5	13	13	M 3 x 3,6	10	7,15	0,031
	LGM_12W	HK1200MW	--	150	0,35	40	30	10,0	19	13	3,0	4,0	14	14	M 3 x 3,6	10	7,65	0,061
15	LGM_15B	HK1500M	--	180	0,75	32	25	14,0	20	14	3,0	5,0	16	16	M 3 x 4	12	8,05	0,050
	LGM_15W	HK1500MW	--	180	0,75	60	45	14,7	22	15	3,5	4,5	16	16	M 3 x 4	12	8,55	0,099

5.5.2 Pneumatic clamping element

5.5.2.1 Pneumatic clamping element for standard guides

The clamping elements of the MK-series close by pneumatic pressure. The clamping elements of the MKS-series close by spring-loaded energy storage. The integrated wedge slide gear achieves high supporting forces. The pressure medium moves the wedge slide gear in a longitudinal direction. The resulting transverse movement presses contact sections with high force against the free surfaces of the section rail guide.



- Note: Consider measurement C/Interfering contour!
 Air connections are located on both sides and can be exchanged according to mounting requirements.
 Only one connection is necessary for function.
- ❶ Adapting plate PMK (accessory)
 - ❷ MK Series: Air filter
 MKS: M5 port (air connection)
 - ❸ MK Series: M5 port (air connection)
 MKS: Air filter / Plus connection M5.
 - ❹ The attachment spring unit on the MKS, is not applicable on the MK.

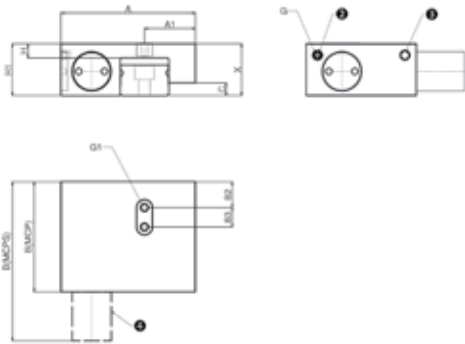
Figure 5.8

Table 5.8 Pneumatic clamping elements for standard guides

Size	Carriage type	Clamping element	Adapter plate	Holding power [N]		Measure [mm]															Mass [kg]																					
				MK	MKS	A	A1	A2	A2	A3	B	B1	B3	B4	C	D	X	G	H	→	MK	MKS																				
15	BG_S15B	MK(S)1501A	--	650	400	55	15	6	34	58	39	15	15,5	12	2,5	24	24	M 4	4,5	16	0,230	0,260																				
	BG_S15F																																									
	BG_H15F																																									
	BG_H15B		PMK15-4													28						0,295	0,325																			
20	BG_S20B	MK(S)2001A	--	1 000	600	66	20	6	43	61	39	20	5	14,4	2,5	28	28	M 5	5,5	20	0,270	0,310																				
	BG_S20F																																									
	BG_H20F																																									
	BG_H20B															30	30					0,320	0,360																			
25	BG_S25B	MK(S)2501A	--	1 200	750	75	20	5	49	56	35	20	5	15,5	5,0	33	33	M 6	8,0	22	0,360	0,420																				
	BG_S25F																																									
	BG_H25F		PMK25-2																																36						0,398	0,458
	BG_X25B		PMK25-6																																40							0,476
30	BG_S30B	MK(S)3001A	--	1 750	1 050	90	22	5	58	68	39	22	8,5	20,5	5,0	42	42	M 8	10,0	25	0,610	0,680																				
	BG_H30F																																									
	BG_H30B		PMK30-3																																45						0,686	0,756
35	BG_S35B	MK(S)3501A	PMK35-4	2 000	1 250	100	24	5	68	67	39	24	7,5	20,5	5,5	48	44	M 8	10,0	28	0,905	1,015																				
	BG_H35F		PMK35-11																																							
	BG_H35B																																		55							1,055
45	BG_S45B	MK(S)4501A	PMK45-6	2 250	1 450	120	26	5	78,8	82	49	26	11,5	26,8	10,5	60	54	M 10	15,0	30	1,600	1,750																				
	BG_H45F		PMK45-16																																							
	BG_H45B																																		70							2,031
55	BG_S55B	MK(S)5501A	PMK55-7	2 250	1 450	128	30	5	87	82	49	30	9,5	30,5	14	70	64	M 10	18,0	30	1,956	2,126																				
	BG_H55F																																									
	BG_H55B		PMK55-17																																80							2,416

5.5.2.2 Pneumatic clamping element for miniature guides

The clamping elements of the MCP-series close by pneumatic pressure. The clamping elements of the MCPS-series close by spring-loaded energy storage and open by pneumatic pressure. They are asymmetrically arranged with respect to the rail axis, which makes it possible to keep the carriage width on one side. The wrap-around clamp is floating, consequently there are no transverse forces in adjoining structures. This also enables a friction connection for the contact sections between the element and linear guide.



Note: Consider measurement C/Interfering contour!

- G: Air connection
- ❶ MCP Series: Air filter
MCPS: M3 port (air connection)
- ❷ MCP Series: M3 port (air connection)
MCPS: Air filter / Plus connection M3.
- ❸ The attachment spring unit on the MCPS is not applicable on the MCP.

Figure 5.9

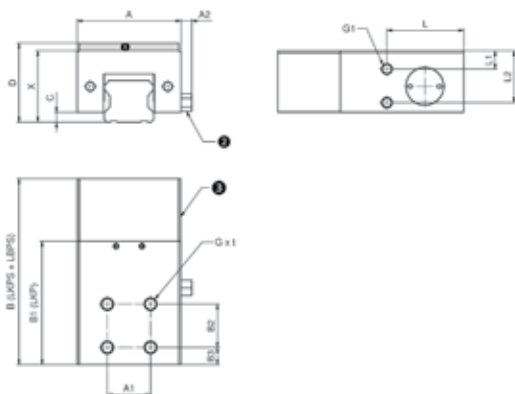
Table 5.9 Pneumatic clamping elements for miniature guides

Size	Carriage type	Clamping element	Holding power [N]		Measure [mm]													Mass [kg]	
			MCP	MCPS	A	A1	B	B1	B2	B3	C	D	X	G	G1	H	H1	MCP	MCPS
09	LGM_09B	MCP(S)0901H	130	80	32,5	9,7	52,5	34	8,25	5,5	2,15	10	M 3	M 2,5	3,3	15	0,070	0,078	0,078
12	LGM_12B	MCP(S)1201A	280	250	37,5	13,2	52,5	34	8,25	5,5	2,95	13	M 3	M 2,5	3,5	16	0,087	0,094	0,094
15	LGM_15B	MCP(S)1501H	320	280	41,5	15,7	52,5	34	8,00	6,0	3,95	16	M 3	M 2,5	3,8	16	0,099	0,105	0,105

5.5.2.3 Compact pneumatic clamping element for standard guides

The clamping elements of the LKP-series close by pneumatic pressure. The clamping elements of the LKPS-series close by spring-loaded energy storage. The integrated wedge slide gear achieves high supporting forces. The pressure medium moves the wedge slide gear in a longitudinal direction.

The resulting transverse movement presses contact sections with high force against the free surfaces of the selected linear guide. The clamping elements of this series are particularly characterized by their compact design.



Note: Consider measurement C/Interfering contour!

Air connections are located on both sides and can be exchanged according to mounting requirements.

Only one connection is necessary for function.

- ❶ Adapting plate PMK (accessory)
- ❷ Air filter
- ❸ Spring unit (LKPS), is not applicable on the MK.LKP

Figure 5.10

Table 5.10 Compact pneumatic clamping elements for standard guides

Size	Carriage type	Clamping element	Adapter plate	Holding power [N]		Dimension [mm]														Mass [kg]							
				LKP	LKPS	A	A1	A2	B	B1	B2	B3	C	D	X	G	G1	L	L1	L2	LKP	LKPS					
15	LGB S15B	LKP(S) 1501AS2		550	400	34	15	--	76	49	8,5	15,0	3,3	24	24	M 4 x 4,5	M3	31,5	4,5	17	0,140	0,180					
	LGB S15F													PLK15-4									28	0,190	0,230		
	LGB H15B																						28			0,230	0,270
20	LGB S20B	LKP(S) 2001AS2		850	650	44	20	--	81	52	7,0	20,0	3,5	28	28	M 5 x 5,5	M 3	33,5	4,5	20,5	0,230	0,270					
	LGB S20F													PLK20-2									30	0,260	0,300		
	LGB H20B																						30			0,310	0,400
25	LGB S25B	LKP(S) 2501AS2		1 100	750	48	20	5	86	57	8,0	20,0	4,5	33	33	M 6 x 6	M 5	35,5	8,5	24	0,310	0,400					
	LGB S25F													PLK25-2									36	0,350	0,440		
	LGB H25F																						34			0,430	0,520
	LGB X25B																						40				
LGB H25B																											

5.6 Lubrication system LU1

5.6.1 Structure

The lubrication system LU1 is developed for the use in combination with grease lubricated lineare guides. In operation, lubrication oil is given by capillary action to the raceways of the profile rail. The function is given in all mounting positions. With the continuous supply of oil, the operation interval of the lubricant inside of the carriage increase substantially.

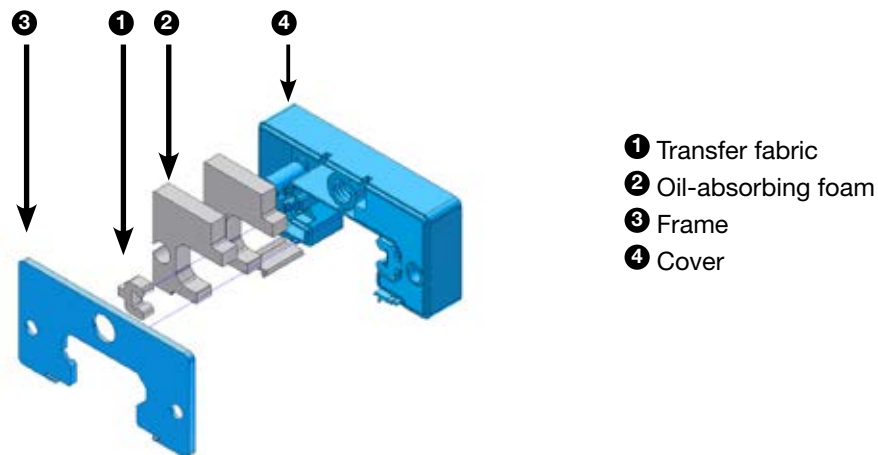


Figure 5.11

The lubrication system LU1 is splitted into two unconnected chambers. By default, the lubrication system LU1 is filled with the high-performance gear and multi-purpose oil Klübersynth® GEM 4 - 220. The combination from the lubrication system LU1 with all sealing options is possible.

5.6.2 Dimension

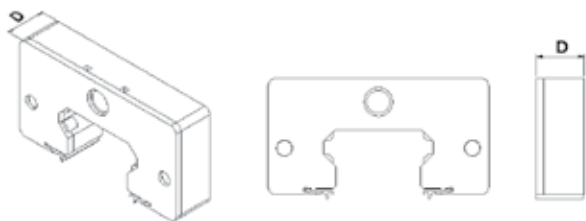


Figure 5.12

Table 5.12

Size	Width D [mm]
LGB15-LU1	10,3
LGB20-LU1	10,3
LGB25-LU1	10,3
LGB30-LU1	10,3
LGB35-LU1	10,7
LGB45-LU1	13,0
LGB55-LU1	13,0

5.6.3 Features

The lubrication system LU1 is designed so that the grease nipples and lubrication connections for the re-lubrication of the carriage with grease can be directly mounted.

This lubrication oil is miscible with all of the NTN-SNR standard greases. However, the greases SNR LUB FOOD and Klübersynth UH 14-151 lose their H1 – registration under this configuration. To refill the lubrication system under normal use is not necessary, but from the top of the cover it is possible. A sideways refill is not provided. Furthermore, the necessary holes could be manufactured by our production. Please contact in this case our NTN-SNR application engineers. It is important that the two chambers of the lubrication system will always be refilled with oil. A filling with other lubrication oils according to customer specifications is possible. It is important that dynamic viscosity according DIN 51 562 T01 from approximately 200 mm²/s is given. Lower viscosity leads to more rapid emptying. Oils with higher viscosity could not be transported in extreme cases.

6. Corrosion protection

NTN-SNR linear guides can be provided in the following versions when special requirements for corrosion protection apply:

Black chrome coating

- Oxide ceramic layer
- Thickness 2...10 µm
- No deformation of the parts
- Resistant to acids, alkalis and solvents
- Relatively soft layer (up to 350 HV), which clears away by rolling over in the area of the raceways
- Color: matt black
- Suitable for applications in the optic industry, medical industry,...

Hard chrome coating

- Galvanic process
- Thickness 2...5 µm
- No deformation of the parts
- Very high hardness of the layer (700...800 HV), good corrosion resistant
- Color: metallic blank
- Suitable for applications in clean rooms, food industry,...

DURALLOY® TDC coating

- Specific thin chrome coating
- Thickness 2,5...4 µm
- No deformation of the parts
- Crack free layer with extreme high hardness (800...1300 HV), very good corrosion resistant
- Color: matt grey
- Suitable for applications in wet areas

We recommend contacting our NTN-SNR application engineers to select a suitable corrosion protection.

7. NTN-SNR linear guides

7.1 Overview

NTN-SNR linear guides are high-quality precision products. They combine customer-orientated product development and high quality requirements. They offer the customer a wide product range for various applications in all areas of industry.

The most important characteristics are:

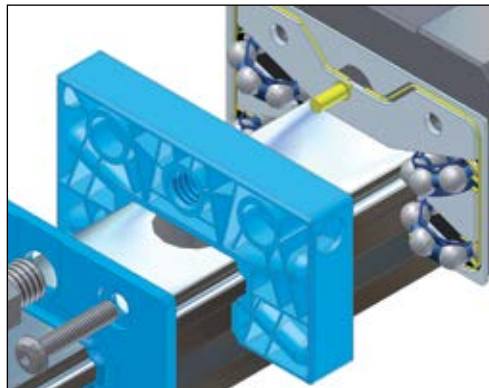
NTN-SNR standard linear guides

- > Arrangement of the race ways at a 45° angle which results in equal load ratings in all main directions
- > Low system friction with a maximum friction coefficient, μ of 0.003 due to circular arc grooves
- > High tolerance compensation and error compensation capability due to DF-arrangement of the race ways
- > Multitude of lubrication connections can be mounted on all sides of the carriage
- > Flange carriages allows screw connection from the top and the bottom
- > All seals in two-lip versions for optimal protection of the carriage against liquid and solid foreign particles
- > Range of sealing options for special applications
- > Linear guides with ball chain and conventional types on one rail
- > Dimensions according to DIN 645-1 and DIN 645-2.



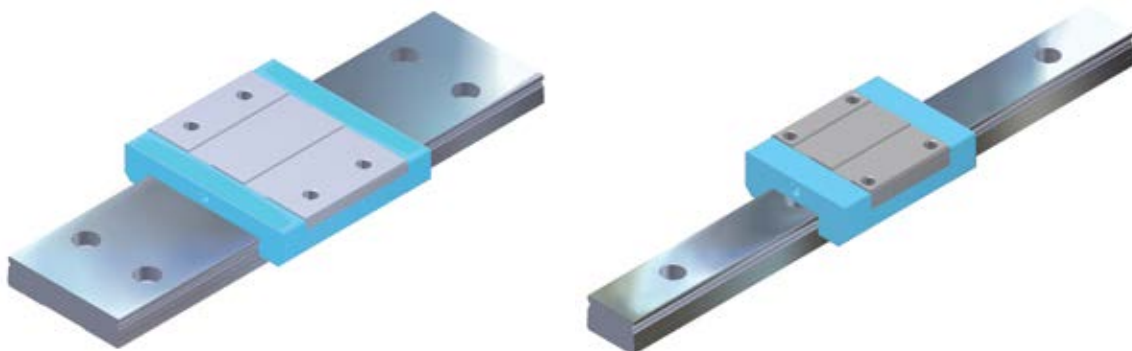
NTN-SNR standard linear guides with ball chains

- > Low noise level
- > Very quiet running due to additional spacer ball at the chain ends
- > Low heat generation
- > Velocity of up to 5 m/s
- > Accelerations of up to 50 m/s²
- > Long-term zero maintenance
- > Long service life
- > Patented ball chain with integrated lubrication reservoirs



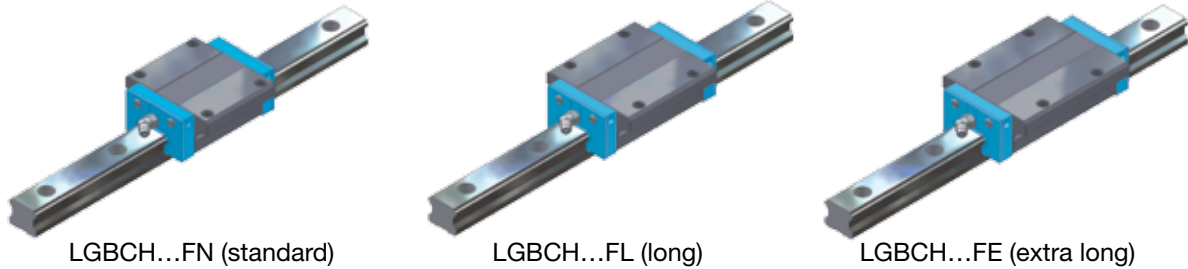
NTN-SNR miniature guides

- > Compact design
- > Profile rail and carriage made of corrosion-resistant material
- > Available in narrow and wide rail versions
- > With ball chain and in conventional type available



Linear guide with ball chain

Carriages with flange, normal design height (p. 86)

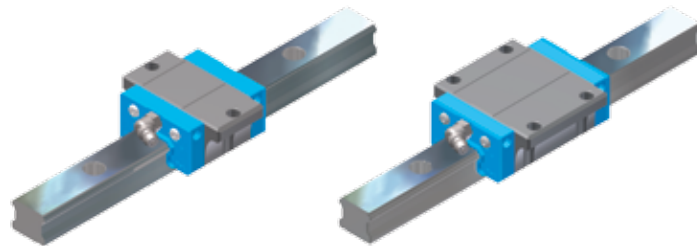


LGBCH...FN (standard)

LGBCH...FL (long)

LGBCH...FE (extra long)

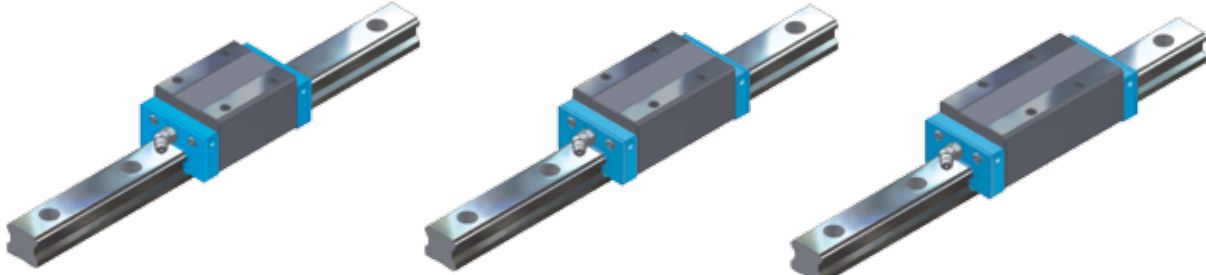
Carriages with flange, flat design height (p. 88)



LGBCS...FS
(short)

LGBCS...FN
(standard)

Carriages in in block design, normal / medium design height (p. 90)

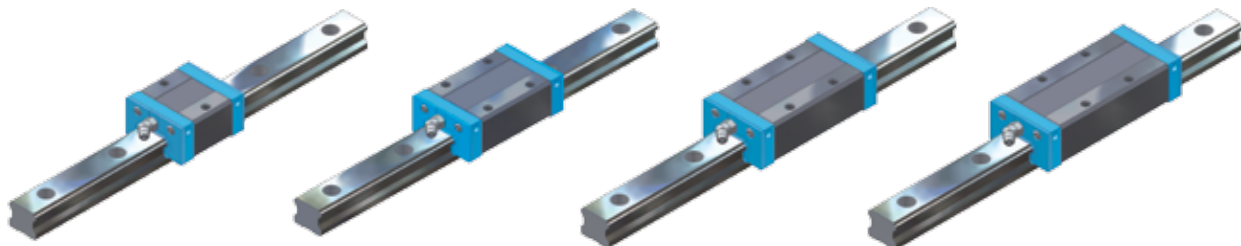


LGBCH / LGBCX...BN (standard)

LGBCH / LGBCX...BL (long)

LGBCH / LGBCX...BE (extra long)

Carriages in block design, flat design height (p. 92)



LGBCS...BS
(short)

LGBCS...BN
(standard)

LGBCS...BL
(long)

LGBCS...BE
(extra long)

Miniature carriages (p. 102)



LGMC...BN
(narrow version, standard)

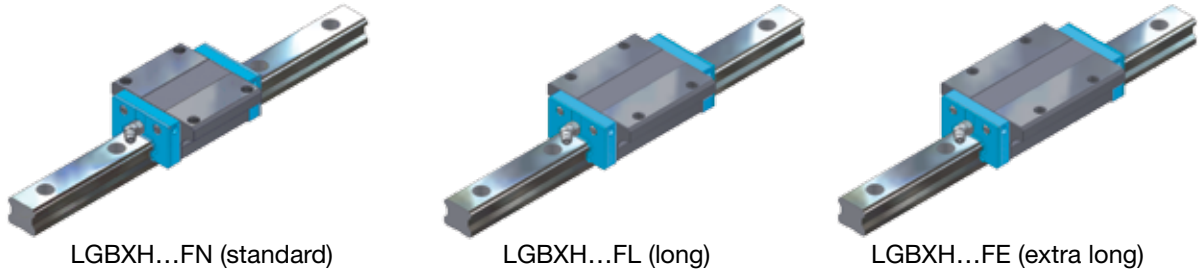
LGMC...BL
(narrow version, long)

LGMC...WN
(wide version, standard)

LGMC...WL
(wide version, long)

Linear guide without ball chain

Carriages with flange, normal design height (p. 94)

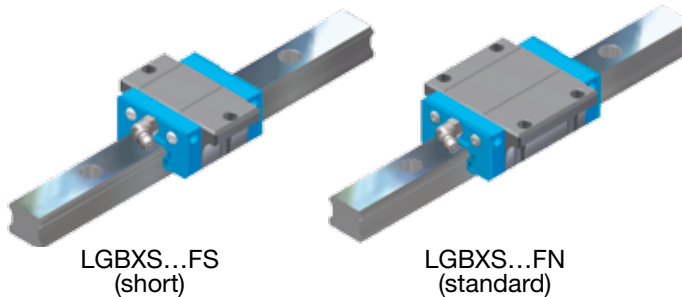


LGBXH...FN (standard)

LGBXH...FL (long)

LGBXH...FE (extra long)

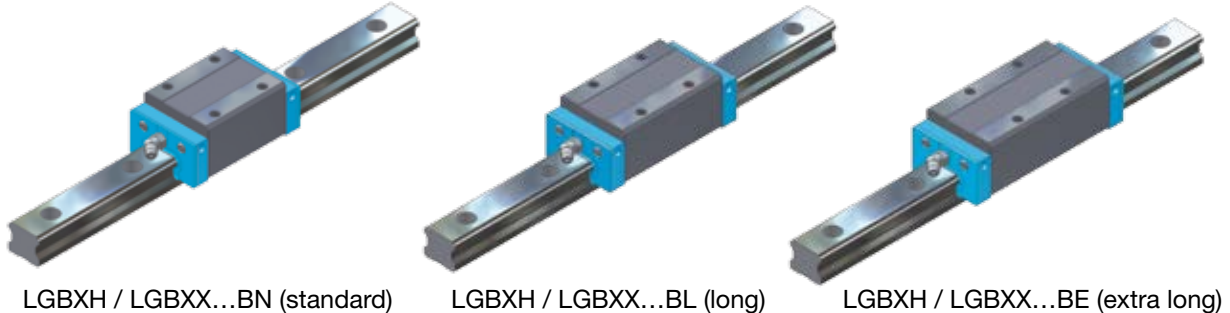
Carriages with flange, flat height (p. 96)



LGBXS...FS
(short)

LGBXS...FN
(standard)

Carriages in block design, normal / medium design height (p. 98)

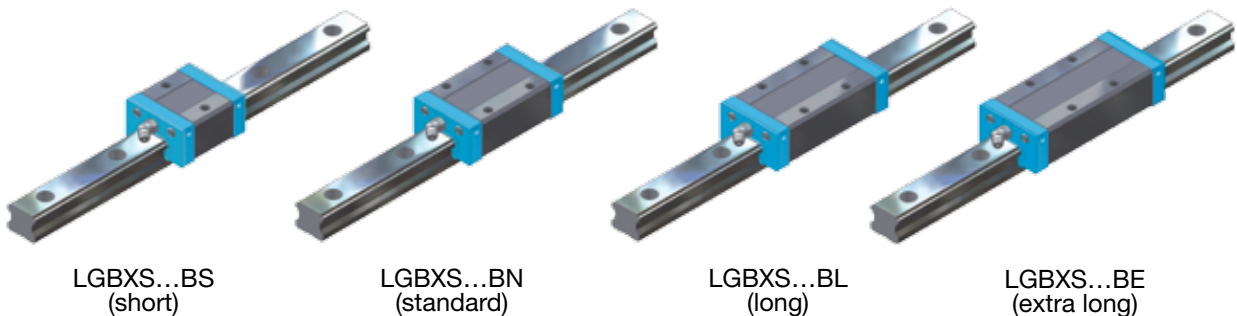


LGBXH / LGBXX...BN (standard)

LGBXH / LGBXX...BL (long)

LGBXH / LGBXX...BE (extra long)

Carriages in block design, flat design height (p. 100)



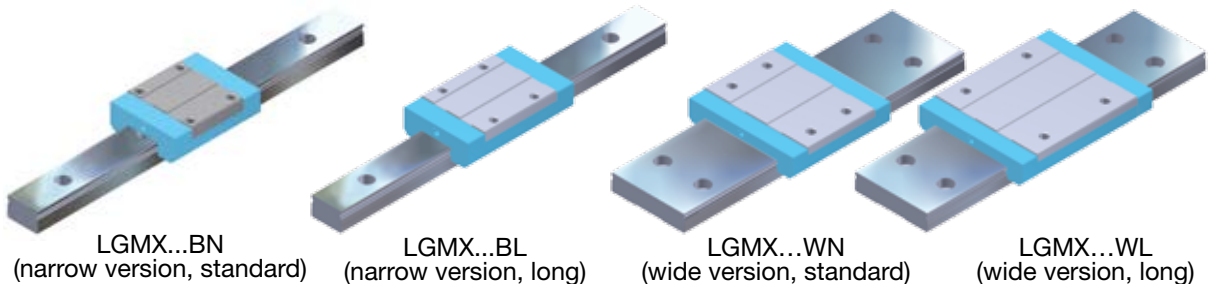
LGBXS...BS
(short)

LGBXS...BN
(standard)

LGBXS...BL
(long)

LGBXS...BE
(extra long)

Miniature carriages (p. 106)



LGMX...BN
(narrow version, standard)

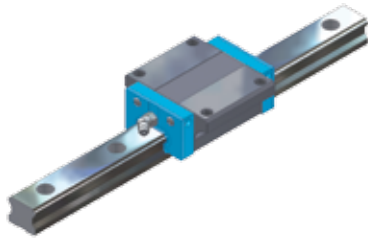
LGMX...BL
(narrow version, long)

LGMX...WN
(wide version, standard)

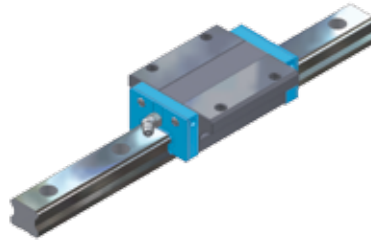
LGMX...WL
(wide version, long)

7.2 LGBCH...F

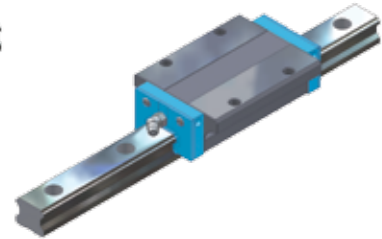
Linear guide with ball chain, carriage in flange design, normal design height



LGBCH...FN, standard



LGBCH...FL, long



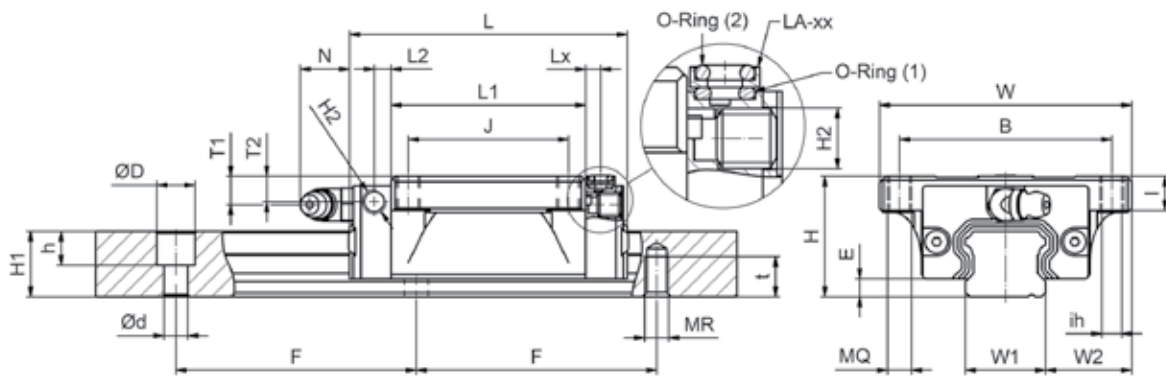
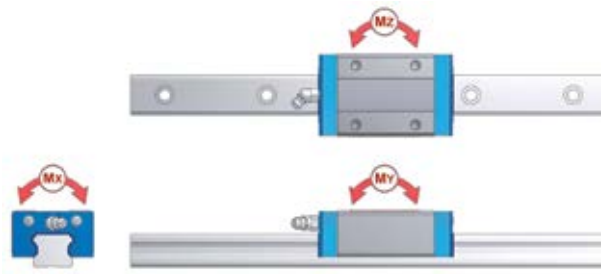
LGBCH...FE, extra long

Example of order code

LGBCH 25 FN 2 SS L 02000 N Z1 - 2 - 0 -20.0 N*

*Explanation to type code in Chapter 8

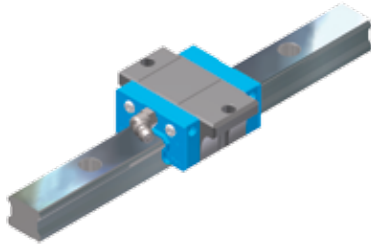
H	System mm					Carriage mm													
	H	W	W2	E	L	B	J	MQ	ih	I	L1	H2	T1	N	T2	L2	L3	Lx	
LGBCH15	FN	24	47	16,0	3,3	58,6	38	30	M 5	4,4	8,0	40,2	M 3 x 0,5	5,5	5,0	4,5	4,20	1,50	3,0
LGBCH15	FL	24	47	16,0	3,3	66,1	38	30	M 5	4,4	8,0	47,7	M 3 x 0,5	5,5	5,0	4,5	4,20	1,50	3,0
LGBCH15	FE	24	47	16,0	3,3	81,1	38	30	M 5	4,4	8,0	62,7	M 3 x 0,5	5,5	5,0	4,5	4,20	1,50	3,0
LGBCH20	FN	30	63	21,5	4,5	69,3	53	40	M 6	5,4	9,0	48,5	M 6 x 1,0	7,1	15,6	6,3	4,25	2,10	3,8
LGBCH20	FL	30	63	21,5	4,5	82,1	53	40	M 6	5,4	9,0	61,3	M 6 x 1,0	7,1	15,6	6,3	4,25	2,10	3,8
LGBCH20	FE	30	63	21,5	4,5	97,3	53	40	M 6	5,4	9,0	76,5	M 6 x 1,0	7,1	15,6	6,3	4,25	2,10	3,8
LGBCH25	FN	36	70	23,5	5,8	79,2	57	45	M 8	7,0	10,0	57,5	M 6 x 1,0	10,2	15,6	9,4	4,65	2,25	5,0
LGBCH25	FL	36	70	23,5	5,8	93,9	57	45	M 8	7,0	10,0	72,2	M 6 x 1,0	10,2	15,6	9,4	4,65	2,25	5,0
LGBCH25	FE	36	70	23,5	5,8	108,6	57	45	M 8	7,0	10,0	86,9	M 6 x 1,0	10,2	15,6	9,4	4,65	2,25	5,0
LGBCH30	FS	42	90	31,0	7,0	64,2	72	--	M 10	8,6	11,0	37,2	M 6 x 1,0	10,0	15,6	5,5	6,00	2,00	5,0
LGBCH30	FN	42	90	31,0	7,0	94,8	72	52	M 10	8,6	11,0	67,8	M 6 x 1,0	10,0	15,6	5,5	6,00	2,00	5,0
LGBCH30	FL	42	90	31,0	7,0	105,0	72	52	M 10	8,6	11,0	78,0	M 6 x 1,0	10,0	15,6	5,5	6,00	2,00	5,0
LGBCH30	FE	42	90	31,0	7,0	130,5	72	52	M 10	8,6	11,0	103,5	M 6 x 1,0	10,0	15,6	5,5	6,00	2,00	5,0
LGBCH35	FS	48	100	33,0	7,5	75,5	82	--	M 10	8,6	12,0	44,5	M 6 x 1,0	11,5	16,0	10,5	7,25	2,00	5,0
LGBCH35	FN	48	100	33,0	7,5	111,5	82	62	M 10	8,6	12,0	80,5	M 6 x 1,0	11,5	16,0	10,5	7,25	2,00	5,0
LGBCH35	FL	48	100	33,0	7,5	123,5	82	62	M 10	8,6	12,0	92,5	M 6 x 1,0	11,5	16,0	10,5	7,25	2,00	5,0
LGBCH35	FE	48	100	33,0	7,5	153,5	82	62	M 10	8,6	12,0	122,5	M 6 x 1,0	11,5	16,0	10,5	7,25	2,00	5,0
LGBCH45	FN	60	120	37,5	8,9	129,0	100	80	M 12	10,6	15,5	94,0	M 8 x 1,25	14,4	16,0	14,5	8,00	2,90	7,5
LGBCH45	FL	60	120	37,5	8,9	145,0	100	80	M 12	10,6	15,5	110,0	M 8 x 1,25	14,4	16,0	14,5	8,00	2,90	7,5
LGBCH45	FE	60	120	37,5	8,9	174,0	100	80	M 12	10,6	15,5	139,0	M 8 x 1,25	14,4	16,0	14,5	8,00	2,90	7,5
LGBCH55	FN	70	140	43,5	12,7	155,0	116	95	M 14	12,6	18,5	116,0	M 8 x 1,25	14,0	16,0	14,5	10,00	2,90	7,5
LGBCH55	FL	70	140	43,5	12,7	193,0	116	95	M 14	12,6	18,5	154,0	M 8 x 1,25	14,0	16,0	14,5	10,00	2,90	7,5
LGBCH55	FE	70	140	43,5	12,7	210,0	116	95	M 14	12,6	18,5	171,0	M 8 x 1,25	14,0	16,0	14,5	10,00	2,90	7,5



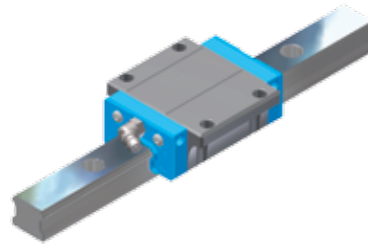
		Rail [mm]							Load rating					Mass			
W1	H1	F	Version L			Version C		kN		kNm			Carriage	kg/ m			
			d	D	h	MR	t	C	C0	MX	MY	MZ			kg	kg/ m	
15	13	60	4,5	7,5	6,0	M 5	8,0	11,67	19,90	0,137	0,120	0,120	0,21	1,28	LG BCH15	FN	
15	13	60	4,5	7,5	6,0	M 5	8,0	14,12	24,05	0,166	0,171	0,171	0,23	1,28	LG BCH15	FL	
15	13	60	4,5	7,5	6,0	M 5	8,0	17,14	31,79	0,220	0,297	0,297	0,29	1,28	LG BCH15	FE	
20	16,3	60	6,0	9,5	8,5	M 6	10,0	17,98	30,96	0,289	0,224	0,224	0,40	2,15	LG BCH20	FN	
20	16,3	60	6,0	9,5	8,5	M 6	10,0	23,30	40,11	0,376	0,366	0,366	0,46	2,15	LG BCH20	FL	
20	16,3	60	6,0	9,5	8,5	M 6	10,0	27,85	49,61	0,464	0,565	0,565	0,61	2,15	LG BCH20	FE	
23	19,2	60	7,0	11,0	9,0	M 6	12,0	25,25	41,73	0,447	0,358	0,358	0,57	2,88	LG BCH25	FN	
23	19,2	60	7,0	11,0	9,0	M 6	12,0	32,44	53,63	0,576	0,577	0,577	0,72	2,88	LG BCH25	FL	
23	19,2	60	7,0	11,0	9,0	M 6	12,0	36,58	64,30	0,691	0,833	0,833	0,89	2,88	LG BCH25	FE	
28	22,8	80	9,0	14,0	12,0	M 8	15,0	18,50	27,51	0,356	0,153	0,153	0,80	4,45	LG BCH30	FS	
28	22,8	80	9,0	14,0	12,0	M 8	15,0	37,33	55,50	0,719	0,560	0,560	1,10	4,45	LG BCH30	FN	
28	22,8	80	9,0	14,0	12,0	M 8	15,0	48,35	71,88	0,931	0,836	0,836	1,34	4,45	LG BCH30	FL	
28	22,8	80	9,0	14,0	12,0	M 8	15,0	53,83	88,18	1,142	1,361	1,361	1,66	4,45	LG BCH30	FE	
34	26,0	80	9,0	14,0	12,0	M 8	17,0	26,72	41,43	0,655	0,275	0,275	1,00	6,25	LG BCH35	FS	
34	26,0	80	9,0	14,0	12,0	M 8	17,0	53,31	82,66	1,307	0,991	0,991	1,50	6,25	LG BCH35	FN	
34	26,0	80	9,0	14,0	12,0	M 8	17,0	66,61	103,29	1,633	1,424	1,424	1,90	6,25	LG BCH35	FL	
34	26,0	80	9,0	14,0	12,0	M 8	17,0	73,29	127,68	2,020	2,330	2,330	2,54	6,25	LG BCH35	FE	
45	31,1	105	14,0	20,0	17,0	M 12	20,0	73,14	111,30	2,353	1,559	1,559	2,27	9,60	LG BCH45	FN	
45	31,1	105	14,0	20,0	17,0	M 12	20,0	86,99	132,39	2,798	2,170	2,170	2,68	9,60	LG BCH45	FL	
45	31,1	105	14,0	20,0	17,0	M 12	20,0	100,52	166,87	3,527	3,455	3,455	3,42	9,60	LG BCH45	FE	
53	38,0	120	16,0	23,0	20,0	M 14	24,0	88,26	136,62	3,385	2,361	2,361	3,44	13,80	LG BCH55	FN	
53	38,0	120	16,0	23,0	20,0	M 14	24,0	119,10	183,14	4,538	4,202	4,202	4,63	13,80	LG BCH55	FL	
53	38,0	120	16,0	23,0	20,0	M 14	24,0	161,43	259,71	6,430	6,617	6,617	5,16	13,80	LG BCH55	FE	

7.3 LGBCS...F

Linear guide with ball chain, carriage in flange design, flat design height



LGBCS...FS, short



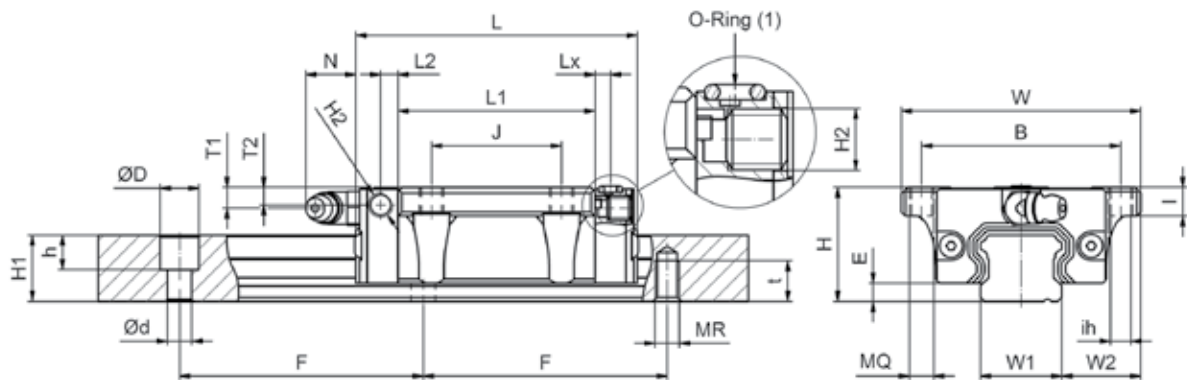
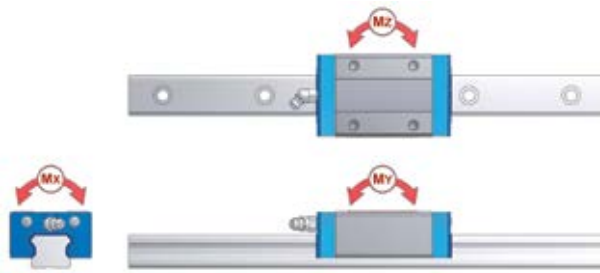
LGBCS...FN, standard

Example of order code

LGBCS 25 FN 2 SS L 02000 N Z1 - 2 - 0 -20.0 N*

*Explanation to type code in Chapter 8

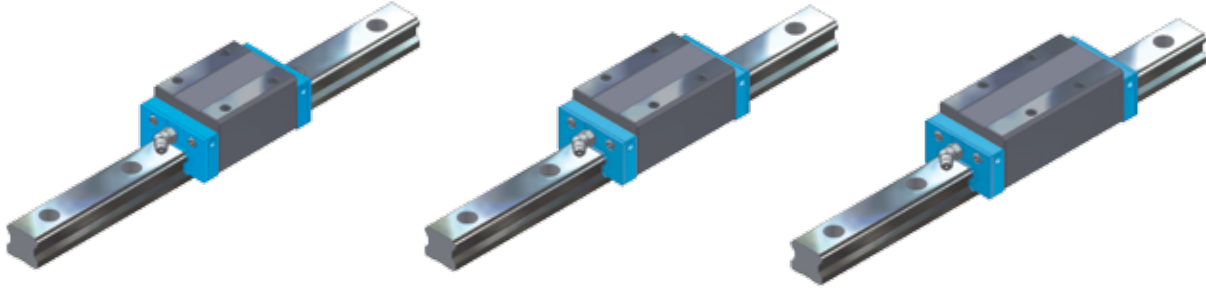
H	System mm					Carriage mm													
	H	W	W2	E	L	B	J	MQ	ih	I	L1	H2	T1	N	T2	L2	L3	Lx	
LGBCS15	FS	24	52	18,5	3,3	40,6	41	--	M 5	4,4	8,0	22,2	M 3 x 0,5	5,5	5,0	4,5	4,20	1,50	3,0
LGBCS15	FN	24	52	18,5	3,3	58,6	41	26	M 5	4,4	8,0	40,2	M 3 x 0,5	5,5	5,0	4,5	4,20	1,50	3,0
LGBCS20	FS	28	59	19,5	4,5	48,3	49	--	M 6	5,4	7,0	27,5	M 6 x 1,0	5,1	15,6	4,3	4,25	2,10	3,8
LGBCS20	FN	28	59	19,5	4,5	69,3	49	32	M 6	5,4	7,0	48,5	M 6 x 1,0	5,1	15,6	4,3	4,25	2,10	3,8
LGBCS25	FS	33	73	25,0	5,8	54,0	60	--	M 8	7,0	7,0	32,3	M 6 x 1,0	7,2	15,6	6,4	4,65	2,25	5,0
LGBCS25	FN	33	73	25,0	5,8	79,2	60	35	M 8	7,0	7,0	57,5	M 6 x 1,0	7,2	15,6	6,4	4,65	2,25	5,0



		Rail [mm]							Load rating					Mass			
		Version L			Version C				kN		kNm			kg	kg/ m		
W1	H1	F	d	D	h	MR	t	C	C0	MX	MY	MZ	Carriage	Rail			
15	13	60	4,5	7,5	6,0	M 5	8,0	5,81	9,90	0,069	0,032	0,032	0,12	1,28	LGBCS15	FS	
15	13	60	4,5	7,5	6,0	M 5	8,0	11,67	19,90	0,137	0,120	0,120	0,19	1,28	LGBCS15	FN	
20	16,3	60	6,0	9,5	8,5	M 6	10,0	9,25	15,93	0,148	0,066	0,066	0,18	2,15	LGBCS20	FS	
20	16,3	60	6,0	9,5	8,5	M 6	10,0	17,98	30,96	0,289	0,224	0,224	0,31	2,15	LGBCS20	FN	
23	19,2	60	7,0	11,0	9,0	M 6	12,0	12,87	21,34	0,230	0,103	0,103	0,33	2,88	LGBCS25	FS	
23	19,2	60	7,0	11,0	9,0	M 6	12,0	25,25	41,73	0,447	0,358	0,358	0,50	2,88	LGBCS25	FN	

7.4 LGBCH...B / LGBCX...B

Linear guide with ball chain, carriages in block design, in normal / medium design height



LGBCH / LGBCX...BN (standard)

LGBCH / LGBCX...BL (long)

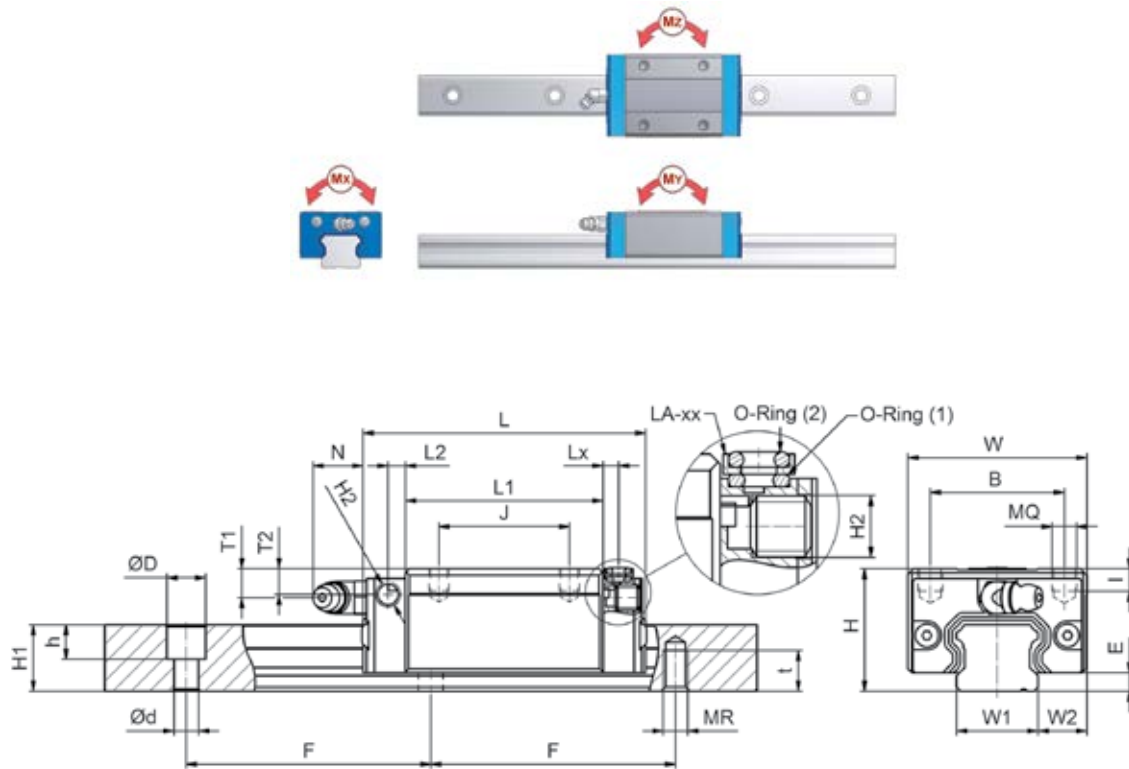
LGBCH / LGBCX...BE (extra long)

Example of order code

LGBCH 25 BN 2 SS L 02000 N Z1 - 2 - 0 -20.0 N*

*Explanation to type code in Chapter 8

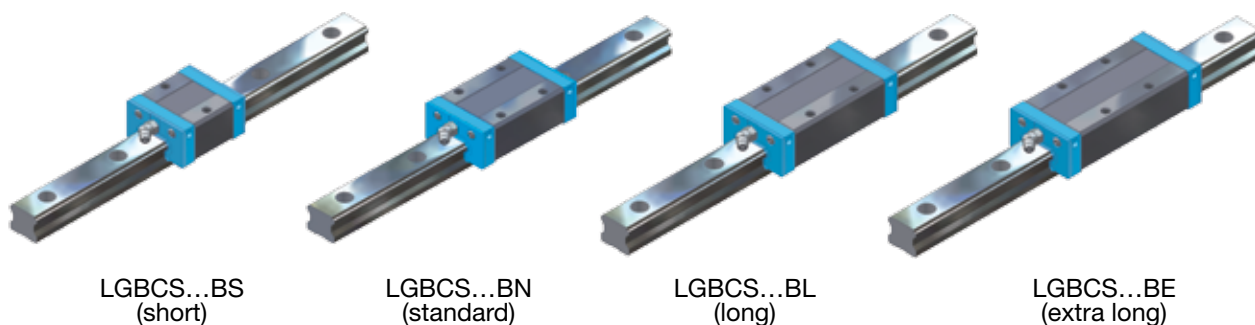
H	System mm					Carriage mm												
	H	W	W2	E	L	B	J	MQ	I	L1	H2	T1	N	T2	L2	L3	Lx	
LGBCH15	BN	28	34	9,5	3,3	58,6	26	26	M 4	6,0	40,2	M 3 x 0,5	9,5	5,0	8,5	4,20	1,50	3,0
LGBCH20	BN	30	44	12,0	4,5	69,3	32	36	M 5	6,5	48,5	M 6 x 1,0	7,1	15,6	6,3	4,25	2,10	3,8
LGBCH20	BL	30	44	12,0	4,5	82,1	32	36	M 5	6,5	61,3	M 6 x 1,0	7,1	15,6	6,3	4,25	2,10	3,8
LGBCH20	BE	30	44	12,0	4,5	97,3	32	50	M 5	6,5	76,5	M 6 x 1,0	7,1	15,6	6,3	4,25	2,10	3,8
LGBCX25	BN	36	48	12,5	5,8	79,2	35	35	M 6	9,0	57,5	M 6 x 1,0	10,2	15,6	9,4	4,65	2,25	5,0
LGBCX25	BL	36	48	12,5	5,8	93,9	35	35	M 6	9,0	72,2	M 6 x 1,0	10,2	15,6	9,4	4,65	2,25	5,0
LGBCX25	BE	36	48	12,5	5,8	108,6	35	50	M 6	9,0	86,9	M 6 x 1,0	10,2	15,6	9,4	4,65	2,25	5,0
LGBCH25	BN	40	48	12,5	5,8	79,2	35	35	M 6	9,0	57,5	M 6 x 1,0	14,2	15,6	13,4	4,65	2,25	5,0
LGBCH25	BL	40	48	12,5	5,8	93,9	35	35	M 6	9,0	72,2	M 6 x 1,0	14,2	15,6	13,4	4,65	2,25	5,0
LGBCH25	BE	40	48	12,5	5,8	108,6	35	50	M 6	9,0	86,9	M 6 x 1,0	14,2	15,6	13,4	4,65	2,25	5,0
LGBCH30	BN	45	60	16,0	7,0	94,8	40	40	M 8	12,0	67,8	M 6 x 1,0	13,0	15,6	8,5	6,00	2,00	5,0
LGBCH30	BL	45	60	16,0	7,0	105,0	40	40	M 8	12,0	78,0	M 6 x 1,0	13,0	15,6	8,5	6,00	2,00	5,0
LGBCH30	BE	45	60	16,0	7,0	130,5	40	60	M 8	12,0	103,5	M 6 x 1,0	13,0	15,6	8,5	6,00	2,00	5,0
LGBCH35	BN	55	70	18,0	7,5	111,5	50	50	M 8	12,0	80,5	M 6 x 1,0	18,5	15,6	13,5	7,25	2,00	5,0
LGBCH35	BL	55	70	18,0	7,5	123,5	50	50	M 8	12,0	92,5	M 6 x 1,0	18,5	15,6	13,5	7,25	2,00	5,0
LGBCH35	BE	55	70	18,0	7,5	153,5	50	72	M 8	12,0	122,5	M 6 x 1,0	18,5	15,6	13,5	7,25	2,00	5,0
LGBCH45	BN	70	86	20,5	8,9	129,0	60	60	M 10	18,0	94,0	M 8 x 1,25	24,5	16,0	24,5	8,00	2,90	7,5
LGBCH45	BL	70	86	20,5	8,9	145,0	60	60	M 10	18,0	110,0	M 8 x 1,25	24,5	16,0	24,5	8,00	2,90	7,5
LGBCH45	BE	70	86	20,5	8,9	174,0	60	80	M 10	18,0	139,0	M 8 x 1,25	24,5	16,0	24,5	8,00	2,90	7,5
LGBCH55	BN	80	100	23,5	12,7	155,0	75	75	M 12	22,0	116,0	M 8 x 1,25	24,0	16,0	24,5	10,00	2,90	7,5
LGBCH55	BL	80	100	23,5	12,7	193,0	75	75	M 12	22,0	154,0	M 8 x 1,25	24,0	16,0	24,5	10,00	2,90	7,5
LGBCH55	BE	80	100	23,5	12,7	210,0	75	95	M 12	22,0	171,0	M 8 x 1,25	24,0	16,0	24,5	10,00	2,90	7,5



		Rail [mm]							Load rating					Mass			
		Version L			Version C				kN		kNm			kg	kg/ m		
W1	H1	F	d	D	h	MR	t	C	C0	MX	MY	MZ	Carriage	Rail			
15	13,0	60	4,5	7,5	6,0	M 5	8,0	11,67	19,90	0,137	0,120	0,120	0,19	1,28	LGBCH15	BN	
20	16,3	60	6,0	9,5	8,5	M 6	10,0	17,98	30,96	0,289	0,224	0,224	0,31	2,15	LGBCH20	BN	
20	16,3	60	6,0	9,5	8,5	M 6	10,0	23,30	40,11	0,376	0,366	0,366	0,36	2,15	LGBCH20	BL	
20	16,3	60	6,0	9,5	8,5	M 6	10,0	27,85	49,61	0,464	0,565	0,565	0,47	2,15	LGBCH20	BE	
23	19,2	60	7,0	11,0	9,0	M 6	12,0	25,25	41,73	0,447	0,358	0,358	0,40	2,88	LGBCH25	BN	
23	19,2	60	7,0	11,0	9,0	M 6	12,0	32,44	53,63	0,576	0,577	0,577	0,54	2,88	LGBCH25	BL	
23	19,2	60	7,0	11,0	9,0	M 6	12,0	36,58	64,30	0,691	0,833	0,833	0,67	2,88	LGBCH25	BE	
23	19,2	60	7,0	11,0	9,0	M 6	12,0	25,25	41,73	0,447	0,358	0,358	0,45	2,88	LGBCH25	BN	
23	19,2	60	7,0	11,0	9,0	M 6	12,0	32,44	53,63	0,576	0,577	0,577	0,66	2,88	LGBCH25	BL	
23	19,2	60	7,0	11,0	9,0	M 6	12,0	36,58	64,30	0,691	0,833	0,833	0,80	2,88	LGBCH25	BE	
28	22,8	80	9,0	14,0	12,0	M 8	15,0	37,33	55,50	0,719	0,560	0,560	0,91	4,45	LGBCH30	BN	
28	22,8	80	9,0	14,0	12,0	M 8	15,0	48,35	71,88	0,931	0,836	0,836	1,04	4,45	LGBCH30	BL	
28	22,8	80	9,0	14,0	12,0	M 8	15,0	53,83	88,18	1,142	1,361	1,361	1,36	4,45	LGBCH30	BE	
34	26,0	80	9,0	14,0	12,0	M 8	17,0	53,31	82,66	1,307	0,991	0,991	1,50	6,25	LGBCH35	BN	
34	26,0	80	9,0	14,0	12,0	M 8	17,0	66,61	103,29	1,633	1,424	1,424	1,80	6,25	LGBCH35	BL	
34	26,0	80	9,0	14,0	12,0	M 8	17,0	73,29	127,68	2,020	2,330	2,330	2,34	6,25	LGBCH35	BE	
45	31,1	105	14,0	20,0	17,0	M 12	20,0	73,14	111,30	2,353	1,559	1,559	2,28	9,60	LGBCH45	BN	
45	31,1	105	14,0	20,0	17,0	M 12	20,0	86,99	132,39	2,798	2,170	2,170	2,67	9,60	LGBCH45	BL	
45	31,1	105	14,0	20,0	17,0	M 12	20,0	100,52	166,87	3,527	3,455	3,455	3,35	9,60	LGBCH45	BE	
53	38,0	120	16,0	23,0	20,0	M 14	24,0	88,26	136,62	3,385	2,361	2,361	3,42	13,80	LGBCH55	BN	
53	38,0	120	16,0	23,0	20,0	M 14	24,0	119,10	183,14	4,538	4,202	4,202	4,57	13,80	LGBCH55	BL	
53	38,0	120	16,0	23,0	20,0	M 14	24,0	161,43	259,71	6,430	6,617	6,617	5,08	13,80	LGBCH55	BE	

7.5 LGBCS...B

Linear guide with ball chain, carriages in block design, flat design height



LGBCS...BS
(short)

LGBCS...BN
(standard)

LGBCS...BL
(long)

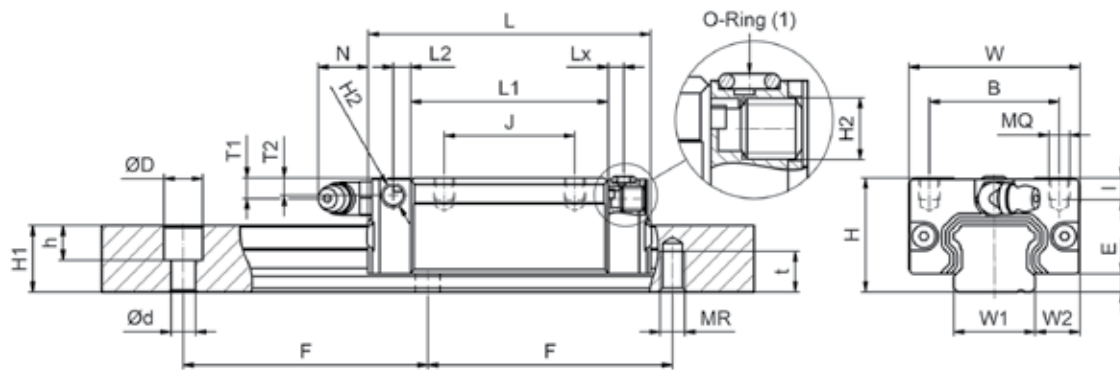
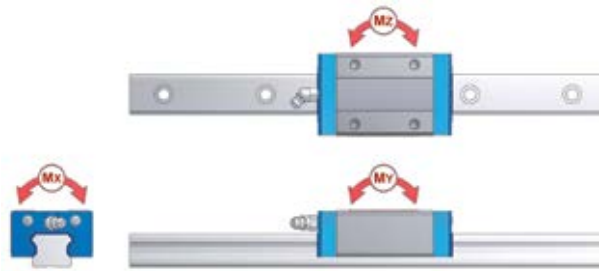
LGBCS...BE
(extra long)

Example of order code

LGBCS 25 BN 2 SS L 02000 N Z1 - 2 - 0 -20.0 N*

*Explanation to type code in Chapter 8

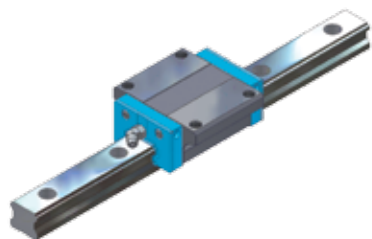
H	System mm					Carriage mm												
	H	W	W2	E	L	B	J	MQ	I	L1	H2	T1	N	T2	L2	L3	Lx	
LGBCS15	BS	24	34	9,5	3,3	40,6	26	--	M 4	4,8	22,2	M 3 x 0,5	5,5	5,0	4,5	4,20	1,50	3,0
LGBCS15	BN	24	34	9,5	3,3	58,6	26	26	M 4	4,8	40,2	M 3 x 0,5	5,5	5,0	4,5	4,20	1,50	3,0
LGBCS15	BL	24	34	9,5	3,3	66,1	26	26	M 4	4,8	47,7	M 3 x 0,5	5,5	5,0	4,5	4,20	1,50	3,0
LGBCS15	BE	24	34	9,5	3,3	81,1	26	34	M 4	4,8	62,7	M 3 x 0,5	5,5	5,0	4,5	4,20	1,50	3,0
LGBCS20	BS	28	42	11,0	4,5	48,3	32	--	M 5	5,5	27,5	M 6 x 1,0	5,1	15,6	4,3	4,25	2,10	3,8
LGBCS20	BN	28	42	11,0	4,5	69,3	32	32	M 5	5,5	48,5	M 6 x 1,0	7,1	15,6	4,3	4,25	2,10	3,8
LGBCS25	BS	33	48	12,5	5,8	54,0	35	--	M 6	6,8	32,3	M 6 x 1,0	7,2	15,6	6,4	4,65	2,25	5,0
LGBCS25	BN	33	48	12,5	5,8	79,2	35	35	M 6	6,8	57,5	M 6 x 1,0	7,2	15,6	6,4	4,65	2,25	5,0
LGBCS30	BS	42	60	16,0	7,0	64,2	40	--	M 8	10,0	37,2	M 6 x 1,0	10,0	15,6	5,5	6,00	2,00	5,0
LGBCS30	BN	42	60	16,0	7,0	94,8	40	40	M 8	10,0	67,8	M 6 x 1,0	10,0	15,6	5,5	6,00	2,00	5,0
LGBCS30	BL	42	60	16,0	7,0	105,0	40	40	M 8	10,0	78,0	M 6 x 1,0	10,0	15,6	5,5	6,00	2,00	5,0
LGBCS30	BE	42	60	16,0	7,0	130,5	40	60	M 8	10,0	103,5	M 6 x 1,0	10,0	15,6	5,5	6,00	2,00	5,0
LGBCS35	BS	48	70	18,0	7,5	75,5	50	--	M 8	10,0	44,5	M 6 x 1,0	11,5	16,0	10,5	7,25	2,00	5,0
LGBCS35	BN	48	70	18,0	7,5	111,5	50	50	M 8	10,0	80,5	M 6 x 1,0	11,5	16,0	10,5	7,25	2,00	5,0
LGBCS35	BL	48	70	18,0	7,5	123,5	50	50	M 8	10,0	92,5	M 6 x 1,0	11,5	16,0	10,5	7,25	2,00	5,0
LGBCS35	BE	48	70	18,0	7,5	153,5	50	72	M 8	10,0	122,5	M 6 x 1,0	11,5	16,0	10,5	7,25	2,00	5,0
LGBCS45	BN	60	86	20,5	8,9	129,0	60	60	M 10	15,5	94,0	M 8 x 1,25	14,4	16,0	14,5	8,00	2,90	7,5
LGBCS45	BL	60	86	20,5	8,9	145,0	60	60	M 10	15,5	110,0	M 8 x 1,25	14,4	16,0	14,5	8,00	2,90	7,5
LGBCS45	BE	60	86	20,5	8,9	174,0	60	80	M 10	15,5	139,0	M 8 x 1,25	14,4	16,0	14,5	8,00	2,90	7,5
LGBCS55	BN	70	100	23,5	12,7	155,0	75	75	M 12	18,0	116,0	M 8 x 1,25	14,0	16,0	14,5	10,00	2,90	7,5
LGBCS55	BL	70	100	23,5	12,7	193,0	75	75	M 12	18,0	154,0	M 8 x 1,25	14,0	16,0	14,5	10,00	2,90	7,5
LGBCS55	BE	70	100	23,5	12,7	210,0	75	95	M 12	18,0	171,0	M 8 x 1,25	14,0	16,0	14,5	10,00	2,90	7,5



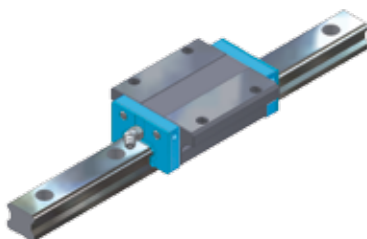
		Rail [mm]							Load rating					Mass			
		Version L			Version C				kN		kNm			kg	kg/ m		
W1	H1	F	d	D	h	MR	t	C	C0	MX	MY	MZ	Carriage	Rail			
15	13,0	60	4,5	7,5	6,0	M 5	8,0	5,81	9,90	0,069	0,032	0,032	0,10	1,28	LGBCS15	BS	
15	13,0	60	4,5	7,5	6,0	M 5	8,0	11,67	19,90	0,137	0,120	0,120	0,17	1,28	LGBCS15	BN	
15	13,0	60	4,5	7,5	6,0	M 5	8,0	14,12	24,05	0,166	0,171	0,171	0,18	1,28	LGBCS15	BL	
15	13,0	60	4,5	7,5	6,0	M 5	8,0	17,14	31,79	0,220	0,297	0,297	0,29	1,28	LGBCS15	BE	
20	16,3	60	6,0	9,5	8,5	M 6	10,0	9,25	15,93	0,148	0,066	0,066	0,17	2,15	LGBCS20	BS	
20	16,3	60	6,0	9,5	8,5	M 6	10,0	17,98	30,96	0,289	0,224	0,224	0,26	2,15	LGBCS20	BN	
23	19,2	60	7,0	11,0	9,0	M 6	12,0	12,87	21,34	0,230	0,103	0,103	0,21	2,88	LGBCS25	BS	
23	19,2	60	7,0	11,0	9,0	M 6	12,0	25,25	41,73	0,447	0,358	0,358	0,38	2,88	LGBCS25	BN	
28	22,8	80	9,0	14,0	12,0	M 8	15,0	18,50	27,51	0,356	0,153	0,153	0,50	4,45	LGBCS30	BS	
28	22,8	80	9,0	14,0	12,0	M 8	15,0	37,33	55,50	0,719	0,560	0,560	0,80	4,45	LGBCS30	BN	
28	22,8	80	9,0	14,0	12,0	M 8	15,0	48,35	71,88	0,931	0,836	0,836	0,94	4,45	LGBCS30	BL	
28	22,8	80	9,0	14,0	12,0	M 8	15,0	53,83	88,18	1,142	1,361	1,361	1,16	4,45	LGBCS30	BE	
34	26,0	80	9,0	14,0	12,0	M 8	17,0	26,72	41,43	0,655	0,275	0,275	0,80	6,25	LGBCS35	BS	
34	26,0	80	9,0	14,0	12,0	M 8	17,0	53,31	82,66	1,307	0,991	0,991	1,20	6,25	LGBCS35	BN	
34	26,0	80	9,0	14,0	12,0	M 8	17,0	66,61	103,29	1,633	1,424	1,424	1,40	6,25	LGBCS35	BL	
34	26,0	80	9,0	14,0	12,0	M 8	17,0	73,29	127,68	2,020	2,330	2,330	1,84	6,25	LGBCS35	BE	
45	31,1	105	14,0	20,0	17,0	M 12	20,0	73,14	111,30	2,353	1,559	1,559	1,64	9,60	LGBCS45	BN	
45	31,1	105	14,0	20,0	17,0	M 12	20,0	86,99	132,39	2,798	2,170	2,170	1,93	9,60	LGBCS45	BL	
45	31,1	105	14,0	20,0	17,0	M 12	20,0	100,52	166,87	3,527	3,455	3,455	2,42	9,60	LGBCS45	BE	
53	38,0	120	16,0	23,0	20,0	M 14	24,0	88,26	136,62	3,385	2,361	2,361	2,67	13,80	LGBCS55	BN	
53	38,0	120	16,0	23,0	20,0	M 14	24,0	119,10	183,14	4,538	4,202	4,202	3,57	13,80	LGBCS55	BL	
53	38,0	120	16,0	23,0	20,0	M 14	24,0	161,43	259,71	6,430	6,617	6,617	3,97	13,80	LGBCS55	BE	

7.6 LGBXH...F

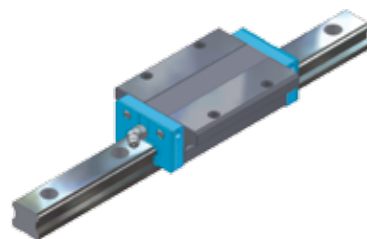
Linear guide without ball chain, carriages in flange design normal design height



LGBXH...FN, standard



LGBXH...FL, long



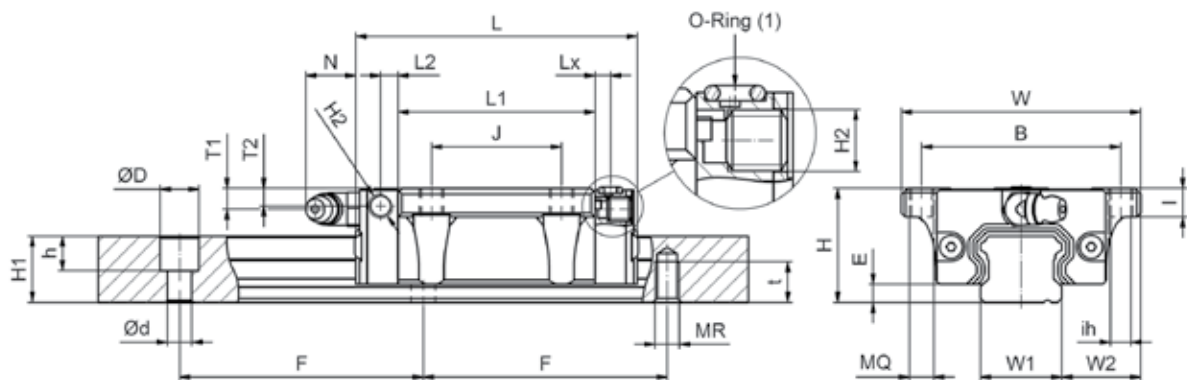
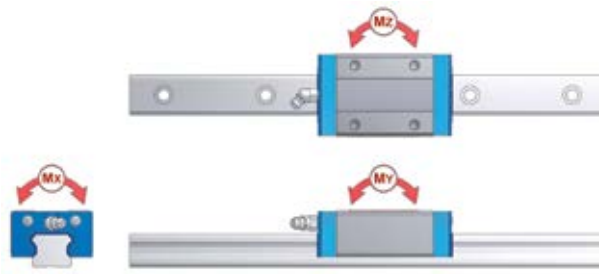
LGBXH...FE, extra long

Example of order code

LGBXH 25 FN 2 SS L 02000 N Z1 - 2 - 0 -20.0 N*

*Explanation to type code in Chapter 8

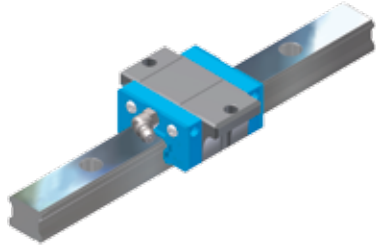
H	System mm					Carriage mm													
	H	W	W2	E	L	B	J	MQ	ih	I	L1	H2	T1	N	T2	L2	L3	Lx	
LGBXH15	FN	24	47	16,0	3,3	58,6	38	30	M 5	4,4	8,0	40,2	M 3 x 0,5	5,5	5,0	4,5	4,20	1,50	3,0
LGBXH15	FL	24	47	16,0	3,3	66,1	38	30	M 5	4,4	8,0	47,7	M 3 x 0,5	5,5	5,0	4,5	4,20	1,50	3,0
LGBXH15	FE	24	47	16,0	3,3	81,1	38	30	M 5	4,4	8,0	62,7	M 3 x 0,5	5,5	5,0	4,5	4,20	1,50	3,0
LGBXH20	FN	30	63	21,5	4,5	69,3	53	40	M 6	5,4	9,0	48,5	M 6 x 1,0	7,1	15,6	6,3	4,25	2,10	3,8
LGBXH20	FL	30	63	21,5	4,5	82,1	53	40	M 6	5,4	9,0	61,3	M 6 x 1,0	7,1	15,6	6,3	4,25	2,10	3,8
LGBXH20	FE	30	63	21,5	4,5	97,3	53	40	M 6	5,4	9,0	76,5	M 6 x 1,0	7,1	15,6	6,3	4,25	2,10	3,8
LGBXH25	FN	36	70	23,5	5,8	79,2	57	45	M 8	7,0	10,0	57,5	M 6 x 1,0	10,2	15,6	9,4	4,65	2,25	5,0
LGBXH25	FL	36	70	23,5	5,8	93,9	57	45	M 8	7,0	10,0	72,2	M 6 x 1,0	10,2	15,6	9,4	4,65	2,25	5,0
LGBXH25	FE	36	70	23,5	5,8	108,6	57	45	M 8	7,0	10,0	86,9	M 6 x 1,0	10,2	15,6	9,4	4,65	2,25	5,0
LGBXH30	FS	42	90	31,0	7,0	64,2	72	--	M 10	8,6	11,0	37,2	M 6 x 1,0	10,0	15,6	5,5	6,00	2,00	5,0
LGBXH30	FN	42	90	31,0	7,0	94,8	72	52	M 10	8,6	11,0	67,8	M 6 x 1,0	10,0	15,6	5,5	6,00	2,00	5,0
LGBXH30	FL	42	90	31,0	7,0	105,0	72	52	M 10	8,6	11,0	78,0	M 6 x 1,0	10,0	15,6	5,5	6,00	2,00	5,0
LGBXH30	FE	42	90	31,0	7,0	130,5	72	52	M 10	8,6	11,0	103,5	M 6 x 1,0	10,0	15,6	5,5	6,00	2,00	5,0
LGBXH35	FS	48	100	33,0	7,5	75,5	82	--	M 10	8,6	12,0	44,5	M 6 x 1,0	11,5	16,0	10,5	7,25	2,00	5,0
LGBXH35	FN	48	100	33,0	7,5	111,5	82	62	M 10	8,6	12,0	80,5	M 6 x 1,0	11,5	16,0	10,5	7,25	2,00	5,0
LGBXH35	FL	48	100	33,0	7,5	123,5	82	62	M 10	8,6	12,0	92,5	M 6 x 1,0	11,5	16,0	10,5	7,25	2,00	5,0
LGBXH35	FE	48	100	33,0	7,5	153,5	82	62	M 10	8,6	12,0	122,5	M 6 x 1,0	11,5	16,0	10,5	7,25	2,00	5,0
LGBXH45	FN	60	120	37,5	8,9	129,0	100	80	M 12	10,6	15,5	94,0	M 8 x 1,25	14,4	16,0	14,5	8,00	2,90	7,5
LGBXH45	FL	60	120	37,5	8,9	145,0	100	80	M 12	10,6	15,5	110,0	M 8 x 1,25	14,4	16,0	14,5	8,00	2,90	7,5
LGBXH45	FE	60	120	37,5	8,9	174,0	100	80	M 12	10,6	15,5	139,0	M 8 x 1,25	14,4	16,0	14,5	8,00	2,90	7,5
LGBXH55	FN	70	140	43,5	12,7	155,0	116	95	M 14	12,6	18,5	116,0	M 8 x 1,25	14,0	16,0	14,5	10,00	2,90	7,5
LGBXH55	FL	70	140	43,5	12,7	193,0	116	95	M 14	12,6	18,5	154,0	M 8 x 1,25	14,0	16,0	14,5	10,00	2,90	7,5
LGBXH55	FE	70	140	43,5	12,7	210,0	116	95	M 14	12,6	18,5	171,0	M 8 x 1,25	14,0	16,0	14,5	10,00	2,90	7,5



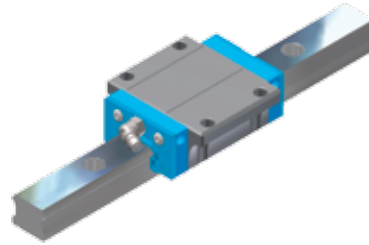
		Rail [mm]							Load rating					Mass			
W1	H1	F	d	Version L			Version C		kN		kNm			Carriage	kg/m		
				D	h	MR	t	C	C0	MX	MY	MZ	FN			FL	FE
15	13	60	4,5	7,5	6,0	M 5	8,0	9,46	19,90	0,137	0,120	0,120	0,21	1,28	LGBXH15	FN	
15	13	60	4,5	7,5	6,0	M 5	8,0	11,39	24,05	0,166	0,171	0,171	0,23	1,28	LGBXH15	FL	
15	13	60	4,5	7,5	6,0	M 5	8,0	13,88	31,79	0,220	0,297	0,297	0,29	1,28	LGBXH15	FE	
20	16,3	60	6,0	9,5	8,5	M 6	10,0	14,56	30,96	0,289	0,224	0,224	0,40	2,15	LGBXH20	FN	
20	16,3	60	6,0	9,5	8,5	M 6	10,0	18,88	40,11	0,376	0,366	0,366	0,46	2,15	LGBXH20	FL	
20	16,3	60	6,0	9,5	8,5	M 6	10,0	22,45	49,61	0,464	0,565	0,565	0,61	2,15	LGBXH20	FE	
23	19,2	60	7,0	11,0	9,0	M 6	12,0	20,44	41,73	0,447	0,358	0,358	0,57	2,88	LGBXH25	FN	
23	19,2	60	7,0	11,0	9,0	M 6	12,0	26,28	53,63	0,576	0,577	0,577	0,72	2,88	LGBXH25	FL	
23	19,2	60	7,0	11,0	9,0	M 6	12,0	29,63	64,30	0,691	0,833	0,833	0,89	2,88	LGBXH25	FE	
28	22,8	80	9,0	14,0	12,0	M 8	15,0	14,99	27,51	0,356	0,153	0,153	0,80	4,45	LGBXH30	FS	
28	22,8	80	9,0	14,0	12,0	M 8	15,0	30,24	55,50	0,719	0,560	0,560	1,10	4,45	LGBXH30	FN	
28	22,8	80	9,0	14,0	12,0	M 8	15,0	39,16	71,88	0,931	0,836	0,836	1,34	4,45	LGBXH30	FL	
28	22,8	80	9,0	14,0	12,0	M 8	15,0	43,60	88,18	1,142	1,361	1,361	1,66	4,45	LGBXH30	FE	
34	26,0	80	9,0	14,0	12,0	M 8	17,0	21,64	41,43	0,655	0,275	0,275	1,00	6,25	LGBXH35	FS	
34	26,0	80	9,0	14,0	12,0	M 8	17,0	44,19	82,66	1,307	0,991	0,991	1,50	6,25	LGBXH35	FN	
34	26,0	80	9,0	14,0	12,0	M 8	17,0	53,96	103,29	1,633	1,424	1,424	1,90	6,25	LGBXH35	FL	
34	26,0	80	9,0	14,0	12,0	M 8	17,0	59,37	127,68	2,020	2,330	2,330	2,54	6,25	LGBXH35	FE	
45	31,1	105	14,0	20,0	17,0	M 12	20,0	59,25	111,30	2,353	1,559	1,559	2,27	9,60	LGBXH45	FN	
45	31,1	105	14,0	20,0	17,0	M 12	20,0	70,47	132,39	2,798	2,170	2,170	2,68	9,60	LGBXH45	FL	
45	31,1	105	14,0	20,0	17,0	M 12	20,0	81,42	166,87	3,527	3,455	3,455	3,42	9,60	LGBXH45	FE	
53	38,0	120	16,0	23,0	20,0	M 14	24,0	71,49	136,62	3,385	2,361	2,361	3,44	13,80	LGBXH55	FN	
53	38,0	120	16,0	23,0	20,0	M 14	24,0	96,46	183,14	4,538	4,202	4,202	4,63	13,80	LGBXH55	FL	
53	38,0	120	16,0	23,0	20,0	M 14	24,0	130,76	259,71	6,430	6,617	6,617	5,16	13,80	LGBXH55	FE	

7.7 LGBXS...F

Linear guide without ball chain, carriage in flange design, flat design height



LGBXS...FS (short)



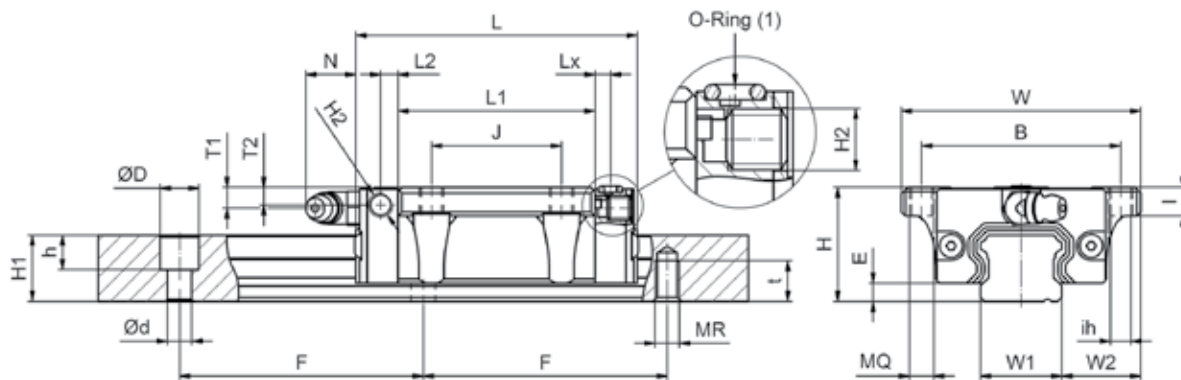
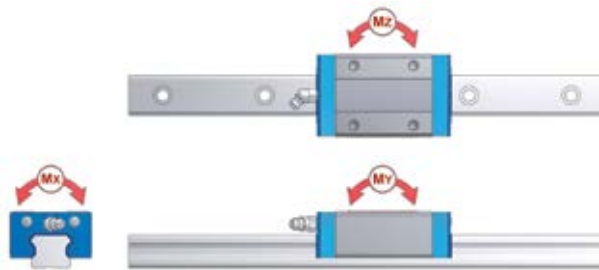
LGBXS...FN, (standard)

Example of order code

LGBXS 25 FN 2 SS L 02000 N Z1 - 2 - 0 -20.0 N*

*Explanation to type code in Chapter 8

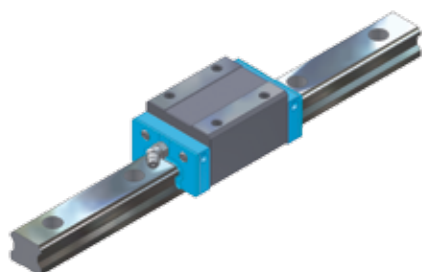
H	System mm					Carriage mm													
	H	W	W2	E	L	B	J	MQ	ih	I	L1	H2	T1	N	T2	L2	L3	Lx	
LGBXS15	FS	24	52	18,5	3,3	40,6	41	--	M 5	4,4	8,0	22,2	M 3 x 0,5	5,5	5,0	4,5	4,20	1,50	3,0
LGBXS15	FN	24	52	18,5	3,3	58,6	41	26	M 5	4,4	8,0	40,2	M 3 x 0,5	5,5	5,0	4,5	4,20	1,50	3,0
LGBXS20	FS	28	59	19,5	4,5	48,3	49	--	M 6	5,4	7,0	27,5	M 6 x 1,0	5,1	15,6	4,3	4,25	2,10	3,8
LGBXS20	FN	28	59	19,5	4,5	69,3	49	32	M 6	5,4	7,0	48,5	M 6 x 1,0	5,1	15,6	4,3	4,25	2,10	3,8
LGBXS25	FS	33	73	25,0	5,8	54,0	60	--	M 8	7,0	7,0	32,3	M 6 x 1,0	7,2	15,6	6,4	4,65	2,25	5,0
LGBXS25	FN	33	73	25,0	5,8	79,2	60	35	M 8	7,0	7,0	57,5	M 6 x 1,0	7,2	15,6	6,4	4,65	2,25	5,0



Rail [mm]								Load rating					Mass			
W1	H1	F	Version L			Version C		kN		kNm			kg	kg/ m		
			d	D	h	MR	t	C	C0	MX	MY	MZ	Carriage	Rail		
15	13	60	4,5	7,5	6,0	M 5	8,0	4,7	9,90	0,069	0,032	0,032	0,12	1,28	LGBXS15	FS
15	13	60	4,5	7,5	6,0	M 5	8,0	9,46	19,90	0,137	0,120	0,120	0,19	1,28	LGBXS15	FN
20	16,3	60	6,0	9,5	8,5	M 6	10,0	7,49	15,93	0,148	0,066	0,066	0,18	2,15	LGBXS20	FS
20	16,3	60	6,0	9,5	8,5	M 6	10,0	14,56	30,96	0,289	0,224	0,224	0,31	2,15	LGBXS20	FN
23	19,2	60	7,0	11,0	9,0	M 6	12,0	10,45	21,34	0,230	0,103	0,103	0,33	2,88	LGBXS25	FS
23	19,2	60	7,0	11,0	9,0	M 6	12,0	20,44	41,73	0,447	0,358	0,358	0,50	2,88	LGBXS25	FN

7.8 LGBXH...B / LGBXX...B

Linear guide without ball chain, carriages in block design, normal / medium design height



LGBXH / LGBXX...BN, standard



LGBXH / LGBXX...BL, long



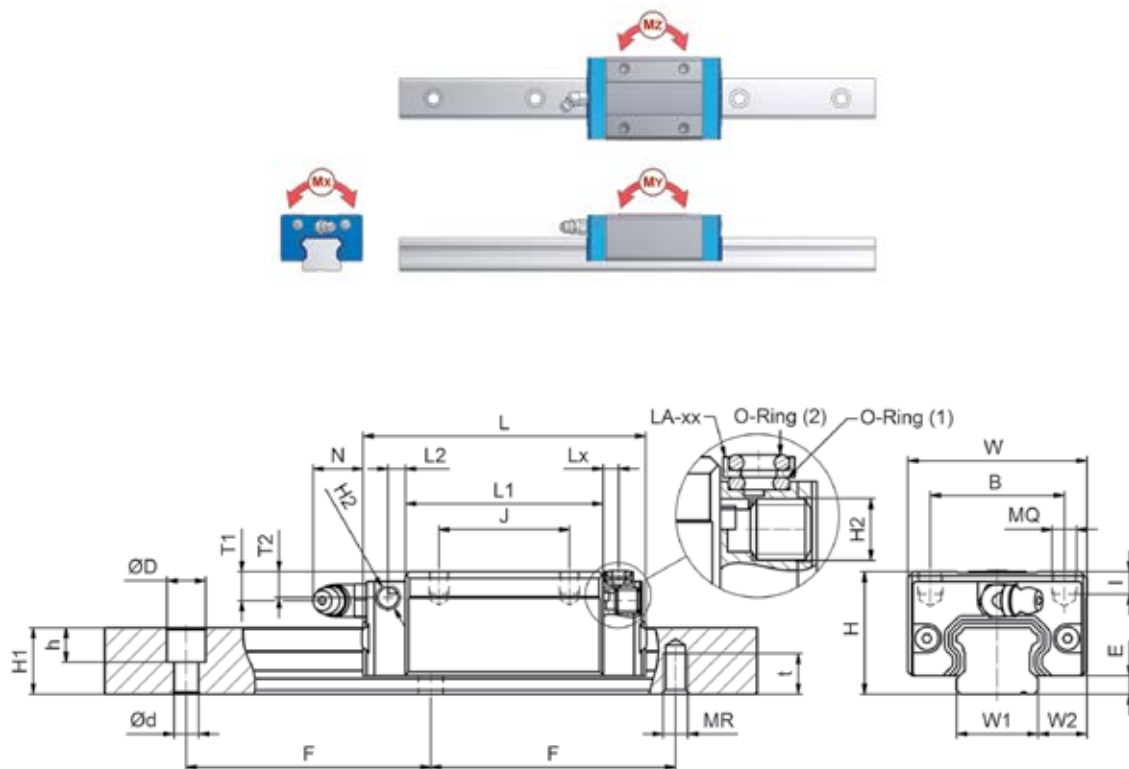
LGBXH / LGBXX...BE, extra long

Example of order code

LGBXH 25 BN 2 SS L 02000 N Z1 - 2 - 0 -20.0 N*

*Explanation to type code in Chapter 8

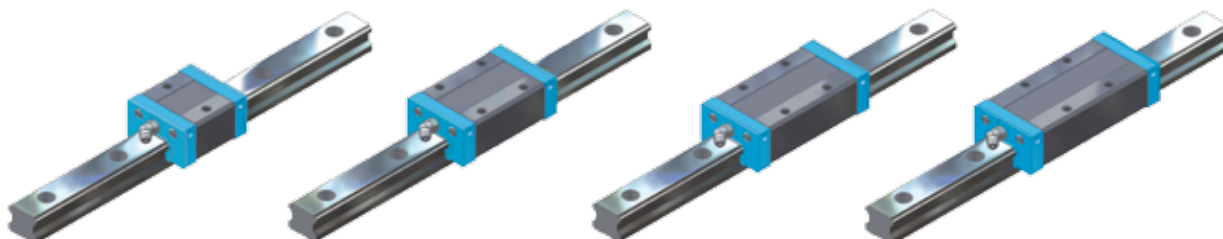
H	System mm					Carriage mm												
	H	W	W2	E	L	B	J	MQ	I	L1	H2	T1	N	T2	L2	L3	Lx	
LGBXH15	BN	28	34	9,5	3,3	58,6	26	26	M 4	6,0	40,2	M 3 x 0,5	9,5	5,0	8,5	4,20	1,50	3,0
LGBXH20	BN	30	44	12,0	4,5	69,3	32	36	M 5	6,5	48,5	M 6 x 1,0	7,1	15,6	6,3	4,25	2,10	3,8
LGBXH20	BL	30	44	12,0	4,5	82,1	32	36	M 5	6,5	61,3	M 6 x 1,0	7,1	15,6	6,3	4,25	2,10	3,8
LGBXH20	BE	30	44	12,0	4,5	97,3	32	50	M 5	6,5	76,5	M 6 x 1,0	7,1	15,6	6,3	4,25	2,10	3,8
LGBXX25	BN	36	48	12,5	5,8	79,2	35	35	M 6	9,0	57,5	M 6 x 1,0	10,2	15,6	9,4	4,65	2,25	5,0
LGBXX25	BL	36	48	12,5	5,8	93,9	35	35	M 6	9,0	72,2	M 6 x 1,0	10,2	15,6	9,4	4,65	2,25	5,0
LGBXX25	BE	36	48	12,5	5,8	108,6	35	50	M 6	9,0	86,9	M 6 x 1,0	10,2	15,6	9,4	4,65	2,25	5,0
LGBXH25	BN	40	48	12,5	5,8	79,2	35	35	M 6	9,0	57,5	M 6 x 1,0	14,2	15,6	13,4	4,65	2,25	5,0
LGBXH25	BL	40	48	12,5	5,8	93,9	35	35	M 6	9,0	72,2	M 6 x 1,0	14,2	15,6	13,4	4,65	2,25	5,0
LGBXH25	BE	40	48	12,5	5,8	108,6	35	50	M 6	9,0	86,9	M 6 x 1,0	14,2	15,6	13,4	4,65	2,25	5,0
LGBXH30	BN	45	60	16,0	7,0	94,8	40	40	M 8	12,0	67,8	M 6 x 1,0	13,0	15,6	8,5	6,00	2,00	5,0
LGBXH30	BL	45	60	16,0	7,0	105,0	40	40	M 8	12,0	78,0	M 6 x 1,0	13,0	15,6	8,5	6,00	2,00	5,0
LGBXH30	BE	45	60	16,0	7,0	130,5	40	60	M 8	12,0	103,5	M 6 x 1,0	13,0	15,6	8,5	6,00	2,00	5,0
LGBXH35	BN	55	70	18,0	7,5	111,5	50	50	M 8	12,0	80,5	M 6 x 1,0	18,5	15,6	13,5	7,25	2,00	5,0
LGBXH35	BL	55	70	18,0	7,5	123,5	50	50	M 8	12,0	92,5	M 6 x 1,0	18,5	15,6	13,5	7,25	2,00	5,0
LGBXH35	BE	55	70	18,0	7,5	153,5	50	72	M 8	12,0	122,5	M 6 x 1,0	18,5	15,6	13,5	7,25	2,00	5,0
LGBXH45	BN	70	86	20,5	8,9	129,0	60	60	M 10	18,0	94,0	M 8 x 1,25	24,5	16,0	24,5	8,00	2,90	7,5
LGBXH45	BL	70	86	20,5	8,9	145,0	60	60	M 10	18,0	110,0	M 8 x 1,25	24,5	16,0	24,5	8,00	2,90	7,5
LGBXH45	BE	70	86	20,5	8,9	174,0	60	80	M 10	18,0	139,0	M 8 x 1,25	24,5	16,0	24,5	8,00	2,90	7,5
LGBXH55	BN	80	100	23,5	12,7	155,0	75	75	M 12	22,0	116,0	M 8 x 1,25	24,0	16,0	24,5	10,00	2,90	7,5
LGBXH55	BL	80	100	23,5	12,7	193,0	75	75	M 12	22,0	154,0	M 8 x 1,25	24,0	16,0	24,5	10,00	2,90	7,5
LGBXH55	BE	80	100	23,5	12,7	210,0	75	95	M 12	22,0	171,0	M 8 x 1,25	24,0	16,0	24,5	10,00	2,90	7,5



Rail [mm]									Load rating					Mass			
W1	H1	F	Version L			Version C		kN		kNm			kg	kg/ m			
			d	D	h	MR	t	C	C0	MX	MY	MZ	Carriage	Rail			
15	13,0	60	4,5	7,5	6,0	M 5	8,0	9,46	19,90	0,137	0,120	0,120	0,19	1,28	LGBXH15	BN	
20	16,3	60	6,0	9,5	8,5	M 6	10,0	14,56	30,96	0,289	0,224	0,224	0,31	2,15	LGBXH20	BN	
20	16,3	60	6,0	9,5	8,5	M 6	10,0	18,88	40,11	0,376	0,366	0,366	0,36	2,15	LGBXH20	BL	
20	16,3	60	6,0	9,5	8,5	M 6	10,0	22,45	49,61	0,464	0,565	0,565	0,47	2,15	LGBXH20	BE	
23	19,2	60	7,0	11,0	9,0	M 6	12,0	20,44	41,73	0,447	0,358	0,358	0,40	2,88	LGBXX25	BN	
23	19,2	60	7,0	11,0	9,0	M 6	12,0	26,28	53,63	0,576	0,577	0,577	0,54	2,88	LGBXX25	BL	
23	19,2	60	7,0	11,0	9,0	M 6	12,0	29,63	64,30	0,691	0,833	0,833	0,67	2,88	LGBXX25	BE	
23	19,2	60	7,0	11,0	9,0	M 6	12,0	20,44	41,73	0,447	0,358	0,358	0,45	2,88	LGBXH25	BN	
23	19,2	60	7,0	11,0	9,0	M 6	12,0	26,28	53,63	0,576	0,577	0,577	0,66	2,88	LGBXH25	BL	
23	19,2	60	7,0	11,0	9,0	M 6	12,0	29,63	64,30	0,691	0,833	0,833	0,80	2,88	LGBXH25	BE	
28	22,8	80	9,0	14,0	12,0	M 8	15,0	30,24	55,50	0,719	0,560	0,560	0,91	4,45	LGBXH30	BN	
28	22,8	80	9,0	14,0	12,0	M 8	15,0	39,16	71,88	0,931	0,836	0,836	1,04	4,45	LGBXH30	BL	
28	22,8	80	9,0	14,0	12,0	M 8	15,0	43,60	88,18	1,142	1,361	1,361	1,36	4,45	LGBXH30	BE	
34	26,0	80	9,0	14,0	12,0	M 8	17,0	44,19	82,66	1,307	0,991	0,991	1,50	6,25	LGBXH35	BN	
34	26,0	80	9,0	14,0	12,0	M 8	17,0	53,96	103,29	1,633	1,424	1,424	1,80	6,25	LGBXH35	BL	
34	26,0	80	9,0	14,0	12,0	M 8	17,0	59,37	127,68	2,020	2,330	2,330	2,34	6,25	LGBXH35	BE	
45	31,1	105	14,0	20,0	17,0	M 12	20,0	59,25	111,30	2,353	1,559	1,559	2,28	9,60	LGBXH45	BN	
45	31,1	105	14,0	20,0	17,0	M 12	20,0	70,47	132,39	2,798	2,170	2,170	2,67	9,60	LGBXH45	BL	
45	31,1	105	14,0	20,0	17,0	M 12	20,0	81,42	166,87	3,527	3,455	3,455	3,35	9,60	LGBXH45	BE	
53	38,0	120	16,0	23,0	20,0	M 14	24,0	71,49	136,62	3,385	2,361	2,361	3,42	13,80	LGBXH55	BN	
53	38,0	120	16,0	23,0	20,0	M 14	24,0	96,46	183,14	4,538	4,202	4,202	4,57	13,80	LGBXH55	BL	
53	38,0	120	16,0	23,0	20,0	M 14	24,0	130,76	259,71	6,430	6,617	6,617	5,08	13,80	LGBXH55	BE	

7.9 LGBXS...B

Linear guide without ball chain, carriages in block design, flat design height



LGBXS...BS, short

LGBXS...BN, standard

LGBXS...BL, long

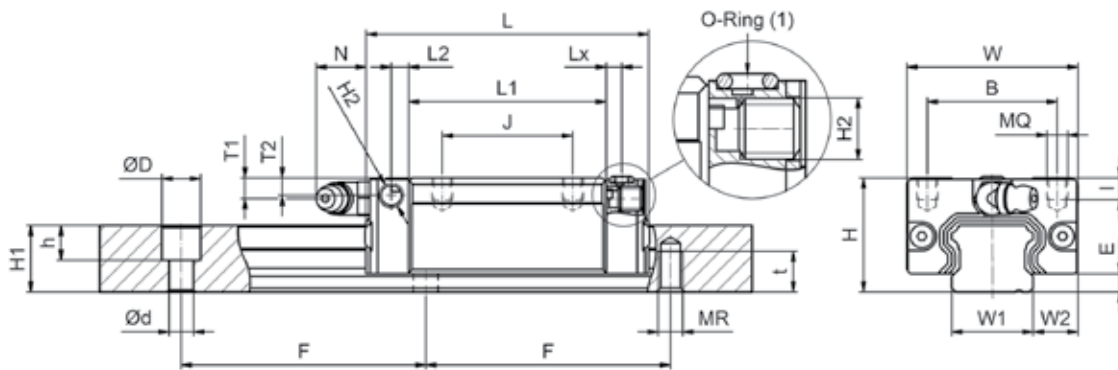
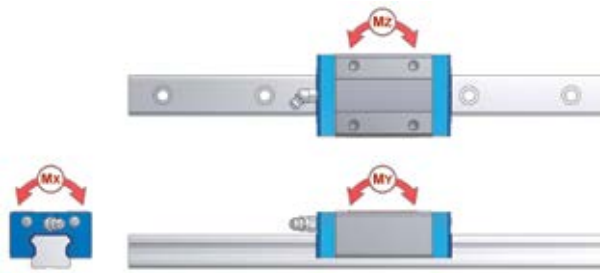
LGBXS...BE, extra long

Example of order code

LGBXS 25 BN 2 SS L 02000 N Z1 - 2 - 0 -20.0 N*

*Explanation to type code in Chapter 8

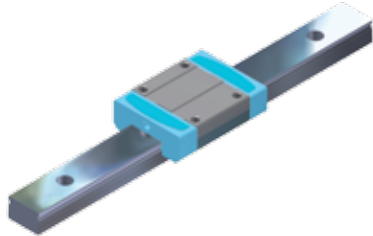
H	System mm					Carriage mm												
	H	W	W2	E	L	B	J	MQ	I	L1	H2	T1	N	T2	L2	L3	Lx	
LGBXS15	BS	24	34	9,5	3,3	40,6	26	--	M 4	4,8	22,2	M 3 x 0,5	5,5	5,0	4,5	4,20	1,50	3,0
LGBXS15	BN	24	34	9,5	3,3	58,6	26	26	M 4	4,8	40,2	M 3 x 0,5	5,5	5,0	4,5	4,20	1,50	3,0
LGBXS15	BL	24	34	9,5	3,3	66,1	26	26	M 4	4,8	47,7	M 3 x 0,5	5,5	5,0	4,5	4,20	1,50	3,0
LGBXS15	BE	24	34	9,5	3,3	81,1	26	34	M 4	4,8	62,7	M 3 x 0,5	5,5	5,0	4,5	4,20	1,50	3,0
LGBXS20	BS	28	42	11,0	4,5	48,3	32	--	M 5	5,5	27,5	M 6 x 1,0	5,1	15,6	4,3	4,25	2,10	3,8
LGBXS20	BN	28	42	11,0	4,5	69,3	32	32	M 5	5,5	48,5	M 6 x 1,0	7,1	15,6	4,3	4,25	2,10	3,8
LGBXS25	BS	33	48	12,5	5,8	54,0	35	--	M 6	6,8	32,3	M 6 x 1,0	7,2	15,6	6,4	4,65	2,25	5,0
LGBXS25	BN	33	48	12,5	5,8	79,2	35	35	M 6	6,8	57,5	M 6 x 1,0	7,2	15,6	6,4	4,65	2,25	5,0
LGBXS30	BS	42	60	16,0	7,0	64,2	40	--	M 8	10,0	37,2	M 6 x 1,0	10,0	15,6	5,5	6,00	2,00	5,0
LGBXS30	BN	42	60	16,0	7,0	94,8	40	40	M 8	10,0	67,8	M 6 x 1,0	10,0	15,6	5,5	6,00	2,00	5,0
LGBXS30	BL	42	60	16,0	7,0	105,0	40	40	M 8	10,0	78,0	M 6 x 1,0	10,0	15,6	5,5	6,00	2,00	5,0
LGBXS30	BE	42	60	16,0	7,0	130,5	40	60	M 8	10,0	103,5	M 6 x 1,0	10,0	15,6	5,5	6,00	2,00	5,0
LGBXS35	BS	48	70	18,0	7,5	75,5	50	--	M 8	10,0	44,5	M 6 x 1,0	11,5	16,0	10,5	7,25	2,00	5,0
LGBXS35	BN	48	70	18,0	7,5	111,5	50	50	M 8	10,0	80,5	M 6 x 1,0	11,5	16,0	10,5	7,25	2,00	5,0
LGBXS35	BL	48	70	18,0	7,5	123,5	50	50	M 8	10,0	92,5	M 6 x 1,0	11,5	16,0	10,5	7,25	2,00	5,0
LGBXS35	BE	48	70	18,0	7,5	153,5	50	72	M 8	10,0	122,5	M 6 x 1,0	11,5	16,0	10,5	7,25	2,00	5,0
LGBXS45	BN	60	86	20,5	8,9	129,0	60	60	M 10	15,5	94,0	M 8 x 1,25	14,4	16,0	14,5	8,00	2,90	7,5
LGBXS45	BL	60	86	20,5	8,9	145,0	60	60	M 10	15,5	110,0	M 8 x 1,25	14,4	16,0	14,5	8,00	2,90	7,5
LGBXS45	BE	60	86	20,5	8,9	174,0	60	80	M 10	15,5	139,0	M 8 x 1,25	14,4	16,0	14,5	8,00	2,90	7,5
LGBXS55	BN	70	100	23,5	12,7	155,0	75	75	M 12	18,0	116,0	M 8 x 1,25	14,0	16,0	14,5	10,00	2,90	7,5
LGBXS55	BL	70	100	23,5	12,7	193,0	75	75	M 12	18,0	154,0	M 8 x 1,25	14,0	16,0	14,5	10,00	2,90	7,5
LGBXS55	BE	70	100	23,5	12,7	210,0	75	95	M 12	18,0	171,0	M 8 x 1,25	14,0	16,0	14,5	10,00	2,90	7,5



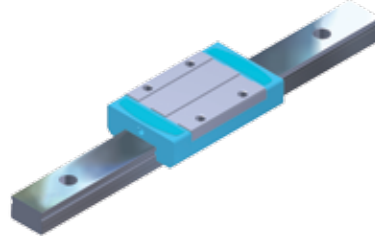
Rail [mm]									Load rating					Mass			
W1	H1	F	Version L			Version C		kN		kNm			kg	kg/ m			
			d	D	h	MR	t	C	C0	MX	MY	MZ	Carriage	Rail			
15	13,0	60	4,5	7,5	6,0	M 5	8,0	4,70	9,90	0,069	0,032	0,032	0,10	1,28	LGBXS15	BS	
15	13,0	60	4,5	7,5	6,0	M 5	8,0	9,46	19,90	0,137	0,120	0,120	0,17	1,28	LGBXS15	BN	
15	13,0	60	4,5	7,5	6,0	M 5	8,0	11,39	24,05	0,166	0,171	0,171	0,18	1,28	LGBXS15	BL	
15	13,0	60	4,5	7,5	6,0	M 5	8,0	13,88	31,79	0,220	0,297	0,297	0,29	1,28	LGBXS15	BE	
20	16,3	60	6,0	9,5	8,5	M 6	10,0	7,49	15,93	0,148	0,066	0,066	0,17	2,15	LGBXS20	BS	
20	16,3	60	6,0	9,5	8,5	M 6	10,0	14,57	30,96	0,289	0,224	0,224	0,22	2,15	LGBXS20	BN	
23	19,2	60	7,0	11,0	9,0	M 6	12,0	10,45	21,34	0,230	0,103	0,103	0,21	2,88	LGBXS25	BS	
23	19,2	60	7,0	11,0	9,0	M 6	12,0	20,44	41,73	0,447	0,358	0,358	0,38	2,88	LGBXS25	BN	
28	22,8	80	9,0	14,0	12,0	M 8	15,0	14,99	27,51	0,356	0,153	0,153	0,50	4,45	LGBXS30	BS	
28	22,8	80	9,0	14,0	12,0	M 8	15,0	30,24	55,50	0,719	0,560	0,560	0,80	4,45	LGBXS30	BN	
28	22,8	80	9,0	14,0	12,0	M 8	15,0	39,16	71,88	0,931	0,836	0,836	0,94	4,45	LGBXS30	BL	
28	22,8	80	9,0	14,0	12,0	M 8	15,0	43,60	88,18	1,142	1,361	1,361	1,16	4,45	LGBXS30	BE	
34	26,0	80	9,0	14,0	12,0	M 8	17,0	21,64	41,43	0,655	0,275	0,275	0,80	6,25	LGBXS35	BS	
34	26,0	80	9,0	14,0	12,0	M 8	17,0	44,19	82,66	1,307	0,991	0,991	1,20	6,25	LGBXS35	BN	
34	26,0	80	9,0	14,0	12,0	M 8	17,0	53,96	103,29	1,633	1,424	1,424	1,40	6,25	LGBXS35	BL	
34	26,0	80	9,0	14,0	12,0	M 8	17,0	59,37	127,68	2,020	2,330	2,330	1,84	6,25	LGBXS35	BE	
45	31,1	105	14,0	20,0	17,0	M 12	20,0	59,25	111,30	2,353	1,559	1,559	1,64	9,60	LGBXS45	BN	
45	31,1	105	14,0	20,0	17,0	M 12	20,0	70,47	132,39	2,798	2,170	2,170	1,93	9,60	LGBXS45	BL	
45	31,1	105	14,0	20,0	17,0	M 12	20,0	81,42	166,87	3,527	3,455	3,455	2,42	9,60	LGBXS45	BE	
53	38,0	120	16,0	23,0	20,0	M 14	24,0	71,49	136,62	3,385	2,361	2,361	2,67	13,80	LGBXS55	BN	
53	38,0	120	16,0	23,0	20,0	M 14	24,0	96,46	183,14	4,538	4,202	4,202	3,57	13,80	LGBXS55	BL	
53	38,0	120	16,0	23,0	20,0	M 14	24,0	130,76	259,71	6,430	6,617	6,617	3,97	13,80	LGBXS55	BE	

7.10 LGMC...B

Miniature guide with ball chain narrow version



LGMC...BN, narrow version, standard



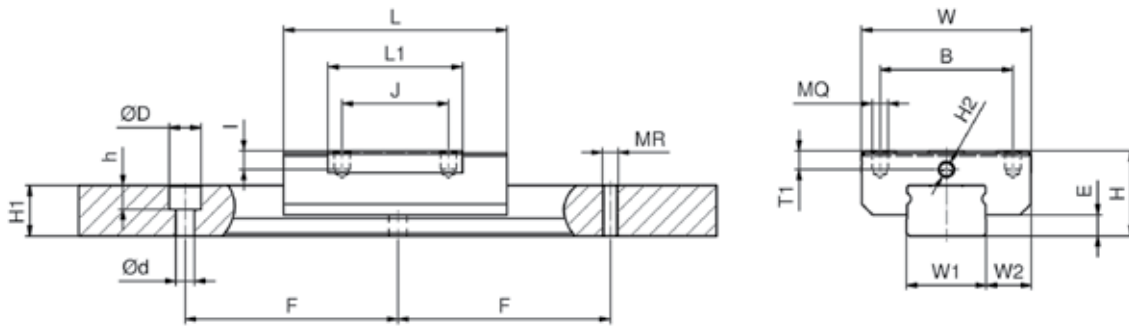
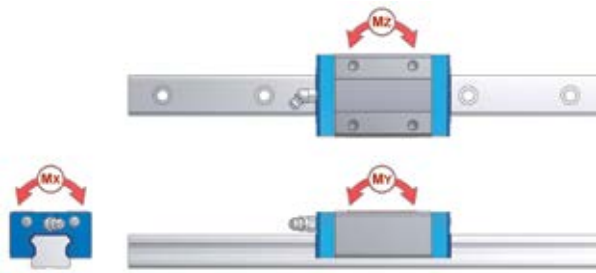
LGMC...BL, narrow version, long

Example of order code

LGMC 12 BN 2 BB L 00195 N Z1 - 2 - 0 -10.0 N*

*Explanation to type code in Chapter 7

H	System mm					Carriage mm								
	H	W	W2	E	L	B	J	MQ	I	L1	H2	T1	N	
LGMC09	BN	10	20	5,5	2,2	30,8	15	10	M 3	2,8	19,5	Ø 1,5	2,4	--
LGMC09	BL	10	20	5,5	2,2	40,5	15	16	M 3	2,8	29,2	Ø 1,5	2,4	--
LGMC12	BN	13	27	7,5	2,0	34,0	20	15	M 3	3,2	20,3	Ø 2,0	3,0	--
LGMC12	BL	13	27	7,5	2,0	47,0	20	20	M 3	3,2	33,3	Ø 2,0	3,0	--
LGMC15	BN	16	32	8,5	4,0	42,0	25	20	M 3	3,5	25,3	M 3 x 0,5	3,5	5
LGMC15	BL	16	32	8,5	4,0	59,8	25	25	M 3	3,5	43,1	M 3 x 0,5	3,5	5



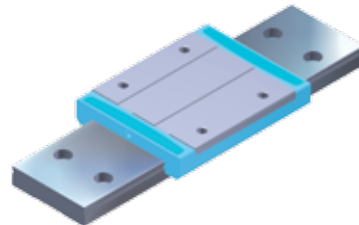
W1	H1	F	WH	Rail [mm]					kN		Load rating kNm			Mass kg		
				d	Version L D	h	Version C MR	t	C	C0	MX	MY	MZ	Carriage	Rail	
9	6,05	20	--	3,5	6,0	3,30	M 4	6,05	2,68	2,28	0,0105	0,0084	0,0084	0,014	0,39	LGMC09 BN
9	6,05	20	--	3,5	6,0	3,30	M 4	6,05	3,47	3,28	0,0149	0,0169	0,0169	0,020	0,39	LGMC09 BL
12	7,25	25	--	3,5	6,0	4,30	M 4	7,25	3,97	3,46	0,0228	0,0118	0,0118	0,029	0,63	LGMC12 BN
12	7,25	25	--	3,5	6,0	4,30	M 4	7,25	5,66	5,21	0,0337	0,0278	0,0278	0,047	0,63	LGMC12 BL
15	9,50	40	--	3,5	6,0	4,50	M 5	9,50	6,60	5,66	0,0397	0,0258	0,0258	0,047	1,05	LGMC15 BN
15	9,50	40	--	3,5	6,0	4,50	M 5	9,50	8,94	7,94	0,0556	0,0546	0,0546	0,078	1,05	LGMC15 BL

7.11 LGMC...W

Miniature guide with ball chain wide version



LGMC...WN, wide version, standard



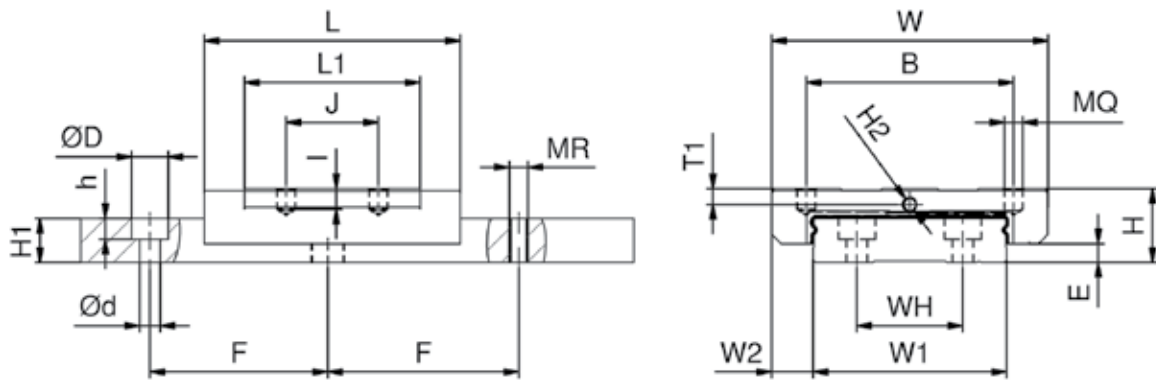
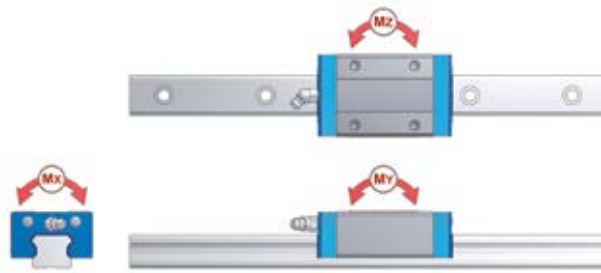
LGMC...WL, wide version, long

Example of order code

LGMC 12 WN 2 BB L 00190 N Z1 - 2 - 0 -15.0 N*

*Explanation to type code in Chapter 8

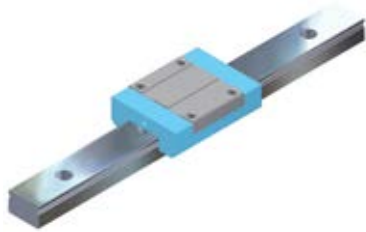
H	System mm					Carriage mm								
	H	W	W2	E	L	B	J	MQ	I	L1	H2	T1	N	
LGMC09	WN	12	30	6,0	3,4	39,0	21	12	M 3	2,8	26,7	Ø 1,5	2,3	--
LGMC09	WL	12	30	6,0	3,4	51,0	23	24	M 3	2,8	38,7	Ø 1,5	2,3	--
LGMC12	WN	14	40	8,0	3,8	44,5	28	15	M 3	3,5	30,5	Ø 2,0	3,0	--
LGMC12	WL	14	40	8,0	3,8	59,1	28	28	M 3	3,5	45,1	Ø 2,0	3,0	--
LGMC15	WN	16	60	9,0	4,0	55,5	45	20	M 4	4,5	38,1	M 3 x 0,5	3,5	5
LGMC15	WL	16	60	9,0	4,0	74,7	45	35	M 4	4,5	57,3	M 3 x 0,5	3,5	5



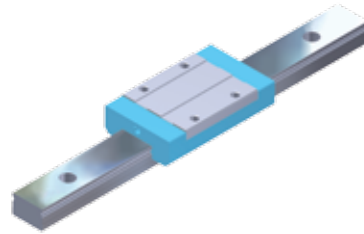
W1	H1	F	WH	Rail [mm]					kN		Load rating kNm			Mass		
				d	Version L D	h	Version C MR	t	C	C0	MX	MY	MZ	kg Carriage	kg/ m Rail	
18	7,50	30	--	3,5	6,0	4,50	M 4	7,50	3,23	3,27	0,0310	0,0149	0,0149	0,030	0,98	LGMC09 WN
18	7,50	30	--	3,5	6,0	4,50	M 4	7,50	4,32	4,27	0,0407	0,0273	0,0273	0,042	0,98	LGMC09 WL
24	8,70	40	--	4,5	8,0	4,50	M 5	8,70	5,41	5,26	0,0655	0,0260	0,0260	0,052	1,53	LGMC12 WN
24	8,70	40	--	4,5	8,0	4,50	M 5	8,70	7,09	6,99	0,0873	0,0481	0,0481	0,076	1,53	LGMC12 WL
42	9,50	40	23	4,5	8,0	4,50	M 5	9,50	9,03	8,48	0,1737	0,0506	0,0506	0,111	2,97	LGMC15 WN
42	9,50	40	23	4,5	8,0	4,50	M 5	9,50	11,31	10,92	0,2233	0,0968	0,0968	0,165	2,97	LGMC15 WL

7.12 LGMX...B

Miniature guide without ball chain narrow version



LGMX...BN, narrow version, standard



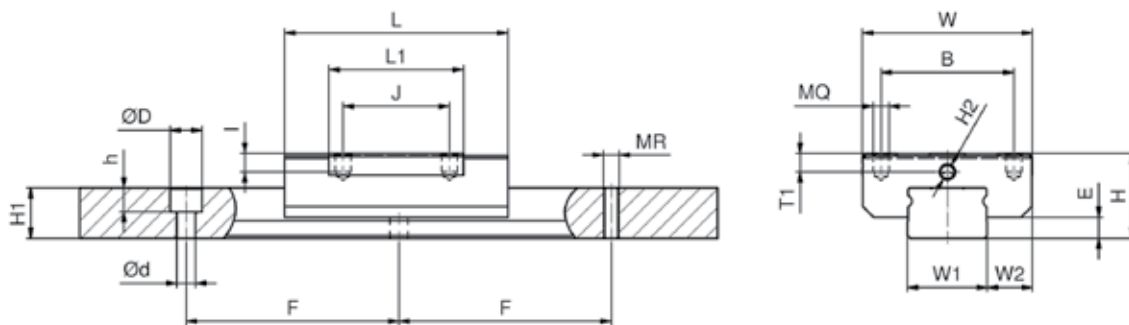
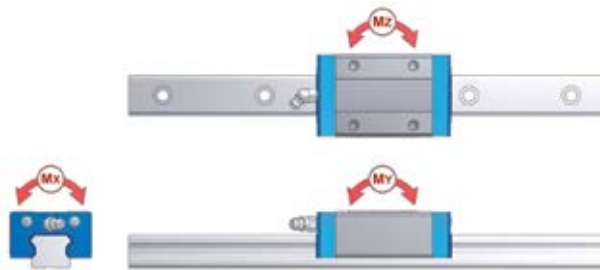
LGMX...BL, narrow version, long

Example of order code

LGMX 12 BN 2 BB L 00195 N Z1 - 2 - 0 -10.0 N*

*Explanation to type code in Chapter 8

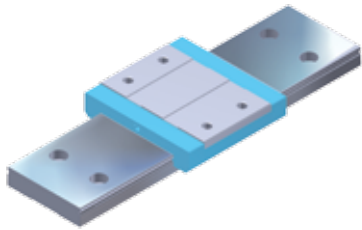
		System mm					Carriage mm							
		H	W	W2	E	L	B	J	MQ	I	L1	H2	T1	N
LGMX07	BN	8	17	5,0	1,5	24,0	12	8	M 2	2,0	13,0	Ø 1,1	1,7	--
LGMX09	BN	10	20	5,5	2,2	30,8	15	10	M 3	2,8	19,5	Ø 1,5	2,4	--
LGMX09	BL	10	20	5,5	2,2	40,5	15	16	M 3	2,8	29,2	Ø 1,5	2,4	--
LGMX12	BN	13	27	7,5	2,0	34,0	20	15	M 3	3,2	20,3	Ø 2,0	3,0	--
LGMX12	BL	13	27	7,5	2,0	47,0	20	20	M 3	3,2	33,3	Ø 2,0	3,0	--
LGMX15	BN	16	32	8,5	4,0	42,0	25	20	M 3	3,5	25,3	M 3 x 0,5	3,5	5
LGMX15	BL	16	32	8,5	4,0	59,8	25	25	M 3	3,5	43,1	M 3 x 0,5	3,5	5



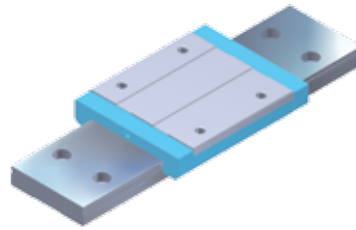
W1	H1	F	WH	Rail [mm]					kN		Load rating kNm			Mass kg		Code
				d	Version L D	h	Version C MR	t	C	C0	MX	MY	MZ	Carriage	Rail	
7	4,70	15	--	2,4	4,4	2,40	M 3	4,70	1,30	1,52	0,0050	0,0031	0,0031	0,010	0,25	LGMX07 BN
9	6,05	20	--	3,5	6,0	3,30	M 4	6,05	2,03	2,28	0,0105	0,0084	0,0084	0,014	0,39	LGMX09 BN
9	6,05	20	--	3,5	6,0	3,30	M 4	6,05	2,78	3,28	0,0149	0,0169	0,0169	0,020	0,39	LGMX09 BL
12	7,25	25	--	3,5	6,0	4,30	M 4	7,25	3,32	3,46	0,0228	0,0118	0,0118	0,029	0,63	LGMX12 BN
12	7,25	25	--	3,5	6,0	4,30	M 4	7,25	4,46	5,21	0,0337	0,0278	0,0278	0,047	0,63	LGMX12 BL
15	9,50	40	--	3,5	6,0	4,50	M 5	9,50	5,51	5,66	0,0397	0,0258	0,0258	0,047	1,05	LGMX15 BN
15	9,50	40	--	3,5	6,0	4,50	M 5	9,50	7,25	7,94	0,0556	0,0546	0,0546	0,078	1,05	LGMX15 BL

7.13 LGMX...W

Miniature guide without ball chain, wide version



LGMX...WN, wide version, standard



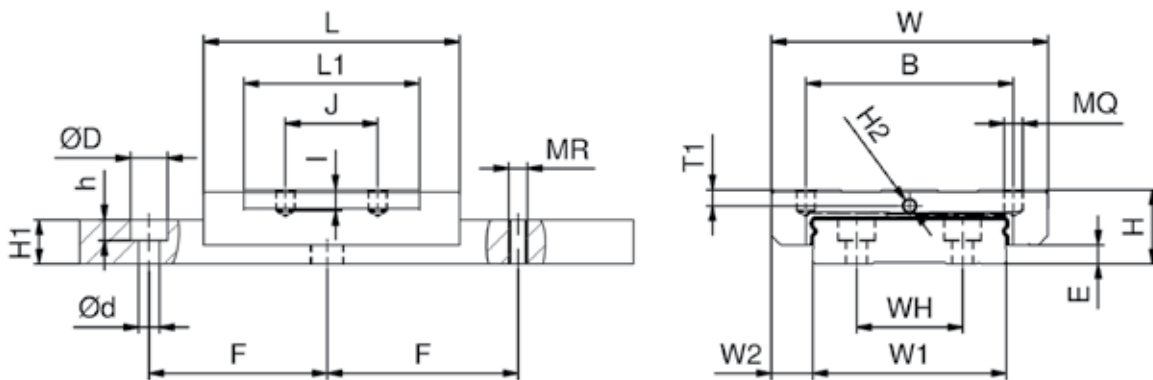
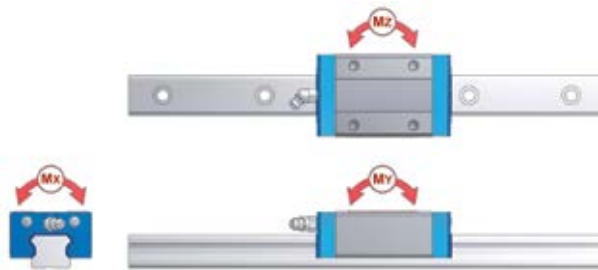
LGMX...WL, wide version, long

Example of order code

LGMX 12 WN 2 BB L 00190 N Z1 - 2 - 0 -15.0 N*

*Explanation to type code in Chapter 8

		System mm					Carriage mm							
		H	W	W2	E	L	B	J	MQ	I	L1	H2	T1	N
LGMX09	WN	12	30	6,0	3,4	39,0	21	12	M 3	2,8	26,7	Ø 1,5	2,3	--
LGMX09	WL	12	30	6,0	3,4	51,0	23	24	M 3	2,8	38,7	Ø 1,5	2,3	--
LGMX12	WN	14	40	8,0	3,8	44,5	28	15	M 3	3,5	30,5	Ø 2,0	3,0	--
LGMX12	WL	14	40	8,0	3,8	59,1	28	28	M 3	3,5	45,1	Ø 2,0	3,0	--
LGMX15	WN	16	60	9,0	4,0	55,5	45	20	M 4	4,5	38,1	M 3 x 0,5	3,5	5
LGMX15	WL	16	60	9,0	4,0	74,7	45	35	M 4	4,5	57,3	M 3 x 0,5	3,5	5



W1	H1	F	WH	Rail [mm]					kN		Load rating kNm			Mass kg		Type
				d	Version L D	Version L h	Version C MR	Version C t	C	C0	MX	MY	MZ	Carriage	Rail	
18	7,50	30	--	3,5	6,0	4,50	M 4	7,50	2,63	3,27	0,0310	0,0149	0,0149	0,030	0,98	LGMX09 WN
18	7,50	30	--	3,5	6,0	4,50	M 4	7,50	3,37	4,27	0,0407	0,0273	0,0273	0,042	0,98	LGMX09 WL
24	8,70	40	--	4,5	8,0	4,50	M 5	8,70	4,36	5,26	0,0655	0,0260	0,0260	0,052	1,53	LGMX12 WN
24	8,70	40	--	4,5	8,0	4,50	M 5	8,70	5,66	6,99	0,0873	0,0481	0,0481	0,076	1,53	LGMX12 WL
42	9,50	40	23	4,5	8,0	4,50	M 5	9,50	7,49	8,48	0,1737	0,0506	0,0506	0,111	2,97	LGMX15 WN
42	9,50	40	23	4,5	8,0	4,50	M 5	9,50	9,03	10,92	0,2233	0,0968	0,0968	0,165	2,97	LGMX15 WL

Rails for NTN-SNR linear guides are produced in standard lengths. Table 7.1 shows the standard length as a function of the design size.

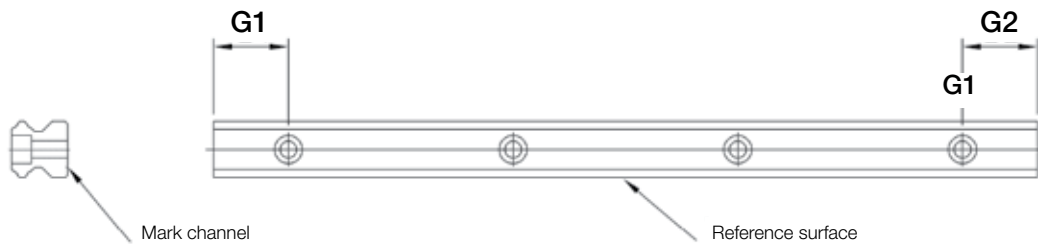
Table 7.1 Standard rail length of NTN-SNR linear guides

Design size	LGBR...						LGMR...				LGMW...			
	15	20	25	30	35	45	55	07	09	12	15	09	12	15
Standard lengths	160	160	160	280	280	360	420	40	55	70	70	50	70	70
	220	220	220	360	360	465	540	55	75	95	110	80	110	110
	280	280	280	440	440	570	660	70	95	120	150	110	150	150
	340	340	340	520	520	675	780	85	115	145	190	140	190	190
	400	400	400	600	600	780	900	100	135	170	230	170	230	230
	460	460	460	680	380	885	1020	115	155	195	270	200	270	270
	520	520	520	760	760	990	1140	130	175	220	310	230	310	310
	580	580	580	840	840	1095	1260	160	195	245	350	260	350	350
	640	640	640	920	920	1200	1380	210	235	270	390	290	390	390
	700	700	700	1000	1000	1305	1500	255	275	295	430	320	430	430
	760	760	760	1080	1080	1410	1620	300	315	345	470	380	470	470
	820	820	820	1160	1160	1515	1740	360	355	395	510	440	550	550
	880	880	880	1240	1240	1620	1860	420	395	445	550	500	630	630
	940	940	940	1320	1320	1725	1980	510	435	495	590	560	710	710
	1000	1000	1000	1400	1400	1830	2100	600	475	545	630	620	790	790
	1060	1060	1060	1480	1480	1935	2220		555	595	670	680	870	870
	1120	1120	1120	1560	1560	2040	2340		635	645	750	740	950	950
	1180	1180	1180	1640	1640	2145	2460		715	695	830	800	1030	1030
	1240	1240	1240	1720	1720	2250	2580		795	745	910	960	1110	1110
	1300	1300	1300	1800	1800	2355	2700		875	795	990	920	1190	1190
	1360	1360	1360	1880	1880	2460	2820			845	1070	980	1270	1270
	1420	1420	1420	1960	1960	2565	2940			945	1150	1040	1350	1350
	1480	1480	1480	2040	2040	2670	3060			995	1230		1430	1430
	1540	1540	1540	2200	2200	2775	3180			1095	1310			
	1600	1600	1600	2360	2360	2880	3300			1195	1390			
	1720	1720	1720	2520	2520	2985	3420			1295				
	1840	1840	1840	2680	2680	3090	3540			1395				
	1960	1960	1960	2840	2840	3195	3660							
	2080	2080	2080	3000	3000	3300	3780							
	2200	2200	2200	3160	3160	3405								
	2320	2320	2320	3320	3320	3510								
	2440	2440	2440	3480	3480	3615								
2560	2560	2560	3640	3640	3720									
2680	2680	2680	3800	3800	3825									
2800	2800	2800												
2920	2920	2920												
3040	3040	3040												
3280	3280	3280												
3520	3520	3520												
3760	3760	3760												
Max. length	4000						900	2000				2000		
F	60	60	60	80	80	105	120	15	20	25	40	30	40	40
G1 = G2	20,0	20,0	20,0	20,0	20,0	22,5	30,0	5,0	7,5	10,0	15,0	10,0	15,0	15,0

Specification of dimensions G1 and G2 is required to determine the position of the first and the last hole in the rail when no standard lengths are used or rails with asymmetrical hole pattern are used. Figure 8.1 shows the definition of the position of dimensions G1 and G2.

Rail arrangement

Suffixes: -1 / -3



Suffixes: -2 / -4

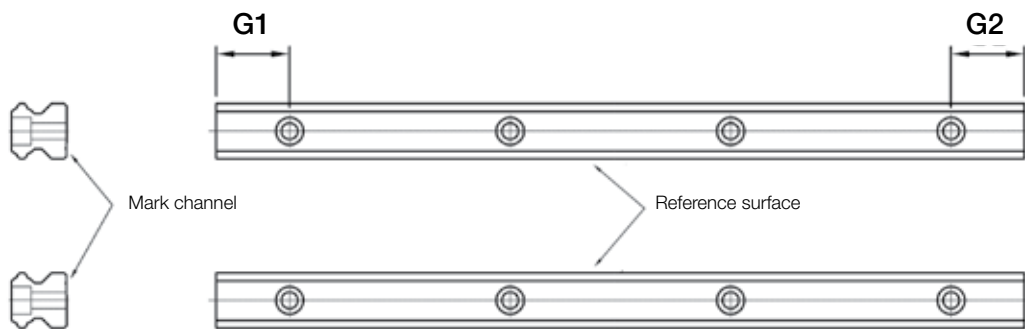


Bild 7.1 Lage der Maße G1, G2 und F

The following versions of linear guide systems can be ordered:

- > Single-segment rail in standard length
- > Single-segment rail in special length, symmetrical ($G1=G2$)
- > Single-segment rail in special length, asymmetrical ($G1 \neq G2$: $G1=...$, $G2=...$)
- > Arbitrarily segmented rail ($G1=G2$). Rails with a length that exceeds the specified maximum standard length for rails delivered in several sections with joints (see Chapter 3.2). The number of sections is defined by NTN-SNR.
- > Segmented rail according to customer specifications. The number of sections is determined by customer specifications. The total length of the rail must be specified when two or several guide segments with joints are ordered.

8. Type code

Order examples for standard systems without options:

Linear guide system:

LGB C H 25 B N 2 SS L 01600 N Z1 - 2 - 0 -20.0 N
 1 2 3 4 5 6 7 8 9 10 11 12 - 13 - 14 15 16

Profile rail:

LGB R 25 L 01600 N 2 - 0 -20.0 N
 1 2 4 9 10 11 13 - 14 15 16

Carriage:

LGB C H 25 B N SS N Z1 - N
 1 2 3 4 5 6 8 11 12 - 16

1	LGB	Series LGB: Standard linear guide LGM: Miniature linear guide
2	C	Version C: Carriage with ball chain X: Conventional carriage W: Profile rail, wide R: Profile rail, narrow
3	H	Design height* H: normal design height S: flat design height X: medium design height <i>* does not apply for miniature guides</i>
4	25	Design size
5	B	Design type of carriage B: Carriage, block design W: Wide carriage, block design F: Carriage, flange design
6	N	Length of the carriage S: Carriage, short L: Carriage, long N: Carriage, standard E: Carriage extra long
7	2	Number of carriages
8	N	Seals SS: Inner, end and side seals (standard sealing) BB: End and side seals EE: Inner, double-end and side seals GG: Inner, double-end and side seals and metal scrapers Additional sealing options see Chapter 5.1.2
9	L	Fastening method for the rail L: Rail with through-holes C: Rail with thread from below
10	01600	Rail length 5-digit specification in [mm]
11	N	Precision N: Normal precision P: P - Precision U: Ultra - Precision H: H - Precision S: Super - Precision
12	Z1	Perload class Z0: No perload Z2: Medium perload ZX: Special perload Z1: Low perload Z3: High perload

Order example for standard system with options:

Linear guide system:

LGB C H 25 B N 2 SS L 01600 N Z1 - 2 - 0 -20.0 S E 02 2 - - 3 -
 1 2 3 4 5 6 7 8 9 10 11 12 13 14 15 16 17 18 19 20 21 22

Profile rail:

LGB R 25 L 01600 N 2 - 0 -20.0 S- 2 -
 1 2 4 9 10 11 13 14 15 16 21 22

Carriage:

LGB C H 25 B N SS N Z1 - S- E 02 2 -
 1 2 3 4 5 6 8 11 12 16 17 18 19 20

13	2	Rail arrangement 1: No information concerning rail arrangement 3: Three rails in parallel	2: Two rails in parallel 4: Four connected rails
14	0	Profile rail segmentation 0: One-segment rail 1: Rail with arbitrary segments 2: Rail segmentation according to drawing	
15	20.0	Starting measure G1 of the rail Definition see Chapter 7.14	
16	N	Special version of the linear guide N: Standard	S: Special version, index follows
17...22		Index for special versions	
17	E	Greases see Table 8.2 and Chapter 4.2.4	
18	02	Lubrication connections see Table 8.1 and Chapter 4.4.1, 4.4.2	
19	2	Material / coatings of the carriages see Table 8.3 and Chapter 6	
20	-	Special versions of the carriages 0: Standard _: Index (A...Z) is given in a case of order	
21	2	Material / coatings of the rails see Table 8.3 and Chapter 6	
22	-	Special version of the rails 0: Standard _: Index (A...Z) is given in a case of order	

Table 8.1 Index of lubrication connections

Lubrication connection (s. chapter 4.4)	Index			
	Miniature guides		Standard guides	
	smaller size 15	size 15	size 15	bigger size 15
End face, grease nipple 67° / locking screw	--	--	--	00
End face, 2 locking screws	--	--	--	01
End face, grease nipple 0° / locking screw	--	02	02	02
End face, grease nipple 45° / locking screw	--	--	--	03
End face, grease nipple 90° / locking screw	--	--	--	04
End face, lubrication extension / locking screw	--	--	--	05
End face, swivel connection / locking screw	--	--	--	06
End face, tube connection, straight / locking screw	--	--	--	07
End face, tube connection 90° / locking screw	--	--	--	08
End face with lubrication hole	09	--	--	--
Lateral on reference side, grease nipple 67° / locking screw	--	--	--	10
Lateral on reference side, 2 locking screws	--	--	--	11
Lateral on reference side, grease nipple 0° / locking screw	--	--	12	12
Lateral on reference side, grease nipple 45° / locking screw	--	--	--	13
Lateral on reference side, grease nipple 90° / locking screw	--	--	--	14
Lateral on reference side, lubrication extension / locking screw	--	--	--	15
Lateral on reference side, swivel connection / locking screw	--	--	--	16
Lateral on reference side, tube connection, straight / locking screw	--	--	--	17
Lateral on reference side, tube connection 90° / locking screw	--	--	--	18
Lateral opposite reference side, grease nipple 67° / locking screw	--	--	--	20
Lateral opposite reference side, 2 locking screws	--	--	--	21
Lateral opposite reference side, grease nipple 0° / locking screw	--	--	22	22
Lateral opposite reference side, grease nipple 45° / locking screw	--	--	--	23
Lateral opposite reference side, grease nipple 90° / locking screw	--	--	--	24
Lateral opposite reference side, lubrication extension / locking screw	--	--	--	25
Lateral opposite reference side, swivel connection / locking screw	--	--	--	26
Lateral opposite reference side, tube connection, straight / locking screw	--	--	--	27
Lateral opposite reference side, tube connection 90° / locking screw	--	--	--	28

XX Standard lubrication connection

Lubrication connection (s. chapter 4.4)	Index			
	Miniature guides		Standard guides	
	smaller size 15	size 15	size 15	bigger size 15
End face, grease nipple 67° / locking screw / LU1 on one side	--	--	--	30
End face, 2 locking screws / LU1 on one side	--	--	--	31
End face, grease nipple 0° / locking screw / LU1 on one side	--	--	32	32
End face, grease nipple 45° / locking screw / LU1 on one side	--	--	--	33
End face, grease nipple 90° / locking screw / LU1 on one side	--	--	--	34
End face, lubrication extension / locking screw / LU1 on one side	--	--	--	35
End face, swivel connection / locking screw / LU1 on one side	--	--	--	36
End face, tube connection, straight / locking screw / LU1 on one side	--	--	--	37
End face, tube connection 90° / locking screw / LU1 on one side	--	--	--	38
Lateral on reference side, grease nipple 67° / locking screw / LU1 on one side	--	--	--	40
Lateral on reference side, 2 locking screws / LU1 on one side	--	--	--	41
Lateral on reference side, grease nipple 0° / locking screw / LU1 on one side	--	--	42	42
Lateral on reference side, grease nipple 45° / locking screw / LU1 on one side	--	--	--	43
Lateral on reference side, grease nipple 90° / locking screw / LU1 on one side	--	--	--	44
Lateral on reference side, lubrication extension / locking screw / LU1 on one side	--	--	--	45
Lateral on reference side, swivel connection / locking screw / LU1 on one side	--	--	--	46
Lateral on reference side, tube connection, straight / locking screw / LU1 on one side	--	--	--	47
Lateral on reference side, tube connection, 90° / locking screw / LU1 on one side	--	--	--	48
Lateral opposite reference side, grease nipple 67° / locking screw / LU1 on one side	--	--	--	50
Lateral opposite reference side, 2 locking screws / LU1 on one side	--	--	--	51
Lateral opposite reference side, grease nipple 0° / locking screw / LU1 on one side	--	--	52	52
Lateral opposite reference side, grease nipple 45° / locking screw / LU1 on one side	--	--	--	53
Lateral opposite reference side, grease nipple 90° / locking screw / LU1 on one side	--	--	--	54
Lateral opposite reference side, lubrication extension / locking screw / LU1 on one side	--	--	--	55
Lateral opposite reference side, swivel connection / locking screw / LU1 on one side	--	--	--	56
Lateral opposite reference side, tube connection, straight / locking screw / LU1 on one side	--	--	--	57
Lateral opposite reference side, tube connection 90° / locking screw / LU1 on one side	--	--	--	58

Lubrication connection (s. chapter 4.4)	Index			
	Miniature guides		Standard guides	
	smaller size 15	size 15	size 15	bigger size 15
End face, grease nipple 67° / locking screw / LU1 on both sides	--	--	--	60
End face, 2 locking screws / LU1 on both sides	--	--	--	61
End face, grease nipple 0° / locking screw / LU1 on both sides	--	--	62	62
End face, grease nipple 45° / locking screw / LU1 on both sides	--	--	--	63
End face, grease nipple 90° / locking screw / LU1 on both sides	--	--	--	64
End face, lubrication extension / locking screw / LU1 on both sides	--	--	--	65
End face, swivel connection / locking screw / LU1 on both sides	--	--	--	66
End face, tube connection, straight / locking screw / LU1 on both sides	--	--	--	67
End face, tube connection 90° / locking screw / LU1 on both sides	--	--	--	68
Lateral on reference side, grease nipple 67° / locking screw / LU1 on both sides	--	--	--	70
Lateral on reference side, 2 locking screws / LU1 on both sides	--	--	--	71
Lateral on reference side grease nipple 0° / locking screw / LU1 on both sides	--	--	72	72
Lateral on reference side, grease nipple 45° / locking screw / LU1 on both sides	--	--	--	73
Lateral on reference side, grease nipple 90° / locking screw / LU1 on both sides	--	--	--	74
Lateral on reference side, lubrication extension / locking screw / LU1 on both sides	--	--	--	75
Lateral on reference side, swivel connection / locking screw / LU1 on both sides	--	--	--	76
Lateral on reference side, tube connection, straight / locking screw / LU1 on both sides	--	--	--	77
Lateral on reference side, tube connection 90° / locking screw / LU1 on both sides	--	--	--	78
Lateral opposite reference side, grease nipple 67° / locking screw / LU1 on both sides	--	--	--	80
Lateral opposite reference side, 2 locking screws / LU1 on both sides	--	--	--	81
Lateral opposite reference side, grease nipple 0° / locking screw / LU1 on both sides	--	--	82	82
Lateral opposite reference side, grease nipple 45° / locking screw / LU1 on both sides	--	--	--	83
Lateral opposite reference side, grease nipple 90° / locking screw / LU1 on both sides	--	--	--	84
Lateral opposite reference side, lubrication extension / locking screw / LU1 on both sides	--	--	--	85
Lateral opposite reference side, swivel connection / locking screw / LU1 on both sides	--	--	--	86
Lateral opposite reference side, tube connection, straight / locking screw / LU1 on both sides	--	--	--	87
Lateral opposite reference side, tube connection 90° / locking screw / LU1 on both sides	--	--	--	88
Lubrication connections according to customer drawing	--	--	99	99

Table 8.2 Index of lubrication greases

Index	Manufacturer	Grease description (see Chapter 4.2.4)
A	NTN-SNR	SNR LUB Heavy Duty (standard grease)
B	Klüber	Without grease, only with Contrakor Fluid H1 preservation oil
C	NTN-SNR	SNR LUB HIGH SPEED+
D	NTN-SNR	SNR LUB HIGH TEMP
E	NTN-SNR	SNR LUB FOOD
F	Klüber	Microlub GL261
G	Klüber	Klübersynth BEM34-32
H	Klüber	Klübersynth UH1 14-151
N	--	Without any greasing
X		Special grease according to customer specifications

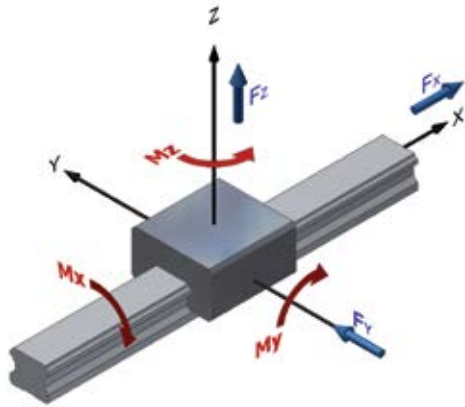
Table 8.3 Index of materials / coatings

Index	Description (see Chapter 6)
0	Standard material
2	Black chrome coating
4	Hard chrome coating
5	DURALLOY® TDC coating

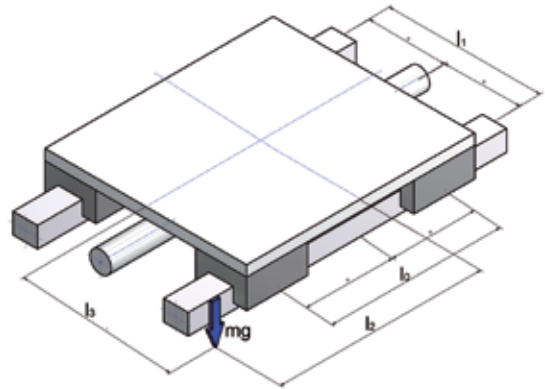
9. Type list

		Page
GRN...	Grease nipple	63, 64
HK...A	Manual clamping element	76
HK...M	Manual clamping element for miniature guides	77
LA-...	Lubrication adapter	66
LBG...-CS	Cover strip	75
LBG...-MT	Mounting tool for cover strip	75
LBG...-SE	Safety element for cover strip	75
LE-...	Lubrication extension	65
LFS	Low Friction Seal	70
LG-CAP...	Plastic rail cap	73
LG-CAP...B	Brass rail cap	73
LGB-BEL...	Bellow for ball guides	74
LGB-BEL...-H-MS	Mounting set for bellows	74
LGB...	Ball Guides	84
LGB...-LU1	Lubrication system LU1	80
LGBC...	Ball carriages with ball chain	86, 102
LGBCH...B	Ball carriages with ball chain, block type, normal height	90
LGBCH...F	Ball carriages with ball chain, flange type, normal height	86
LGBCS...B	Ball carriages with ball chain, block type, flat version	92
LGBCS...F	Ball carriages with ball chain, flange type, flat version	88
LGBCX...B	Ball carriages with ball chain, block type, medium height	90
LGBR...	Narrow rail for ball guides	110
LGBX...	Conventional ball carriages	94, 106
LGBXH...B	Conventional ball carriages, block type, normal height	98
LGBXH...F	Conventional ball carriages, flange type, normal height	94
LGBXS...B	Conventional ball carriages, block type, flat version	100
LGBXS...F	Conventional ball carriages, flange type, flat version	96
LGBXX...B	Conventional ball carriages, block type, medium height	98
LGM...	Miniature guides	84, 102
LGMC...	Miniature carriages with ball chain	102
LGMC...B	Miniature carriages with ball chain, narrow version	102
LGMC...W	Miniature carriages with ball chain, wide version	104
LGMR...	Narrow rail for miniature guides	110
LGMW...	Wide rail for miniature guides	110
LGMX...	Conventional miniature carriages	106
LGMX...B	Conventional miniature carriages, narrow version	106
LGMX...W	Conventional miniature carriages, wide version	108
LH-...	Lubrication tubel connection	65
LKP...	Compact pneumatic clamping element	80
LKPS...	Compact pneumatic safety clamping element	80
LS-...	Lubrication swivel connection	65
MCP...	Pneumatic clamping element for miniature guides	79
MCPS...	Pneumatic safety clamping element for miniature guides	79
MK...	Pneumatic clamping element	78
MKS...	Pneumatic safety clamping element	78
MLS	Multi Layer Seal	70
ORI...	O-Ring	66
PHK...	Adapter plate for manual clamping element	76
PLK...	Adapter plate for compact pneumatic clamping element	79, 80
PMK...	Adapter plate for pneumatic clamping element	78

Coordinate system



Position of the loads



Loads

Load		longitudinal [mm]		horizontal [mm]	vertical [mm]	Travel percentage	Comments
Centre of gravity	[kg]	x_{max}	x_{min}	y	z	[%]	
m1							
m2							
m3							
m4							
m5							
External force		longitudinal [mm]		horizontal [mm]	vertical [mm]	Travel percentage	Comments
Point of action	[N]	x_{max}	x_{min}	y	z	[%]	
Fx		not applicable					
Fy				not applicable			
Fz					not applicable		

Drawing:

11. Index

A		Grease nipple	63
Accessories	70	Guide to queries	117
Amount of lubricant		H	
Initial lubrication	67	Hardness factor	17
Initial operation	67	Heat generation	8
Relubrication	67, 68	Hertz-type compression	14
Re-operation	68	I	
Arrangement	48	Index for special versions	112
B		Initial lubrication	67, 69
Ball chain	8, 82	Installation conditions	50
Bellows	73	Installation instructions	50
C		Installation faults	7
Cage	12	Installation position	22, 49
Circular arc groove	6, 41, 82	Installation surface	50, 51
Clamping- and Braking Elements	76	Installation tolerance	52
Manual claming element	76, 77	Height tolerances	53
Pneumatic claming element	78, 79	Height tolerances in longitudinal direction ..	55
Compact pneumatic Clamping elements	80	Parallelism tolerance	52
Clean room	60	J	
Coating	81, 115	Joint	47, 111
Black chrome coating	81	L	
Duralloy coating ..	81	LFS	70, 71
Hard chrome coating	81	Load factor	19
Contact factor	18	Load ration	41
Contact surfaces	8	Locating edge	45, 50
Coordinate system	15	Low-Friction-Seal	70
Corrosion protection	81	Lubricant	
Corrosion protection oil	50	Properties	57
Cover strip	75	Low-viscosity grease	59
Mounting tool	75	Preservation oils	58, 60
Safety elemet	75	Lubrication grease	60, 80
D		Lubrication oil	58
DB and DF-configuration	7, 40, 82	Lubrication	
Differential slip	6	Influencing factors	57
Dimension G	1105	Relubrication intervals	69
Driving resistance	11, 35, 42, 43	Lubrication film	57
Distance ball	11	Lubrication adapter	65
Driving force	43	Lubrication connections	65, 114
Dynamic load rating	14	Lubrication channel	58
E		Lubrication depot	9, 83
End caps	66	Lubrication film	8
Environmental temperature	18	Lubrication methods	
Equivalent load	20, 23	Grease gun	66
Dynamic	23	Manual grease gun	61
Equivalence factors	20, 21	Lubricant dispenser	61, 67
Error compensation	40	Lubricator LU1	
Excess length	47	LU1	80
F			
Fastening hole	73		
Fastening screws	56		
Fastening torque	56		
Food industry	58		
Friction coefficient	42		
Friction force	41		
G			
Gothic arc groove	6, 41		

M
 Main and auxiliary guide..... 45
 Main load directions 15, 37, 82
 Maximum acceleration 83
 Maximum velocity 83
 MLS
 Multi-Layer-Seal 70
 Mounting-Set 74, 75

N
 Noise reduction 57, 60
 Noise generation 9
NTN-SNR linear guides
 Overview with ball chain 84
 Overview without ball chain 85

O
 Osculation 5, 41

P
 Pharmaceutical industry 58
 Pitching 15
 Point and area contact 5
 Precision classes 38
 Width tolerance 38, 39
 Height tolerance 38, 39
 Parallelism deviation 38, 39
 Preload 35, 36, 40
 Preload classes 35

R
 Race way 5, 57
 Radial clearance 35, 36
 Rail caps 73
 Rail joint see joint
 Reference surface 47
 Reflux holes 9
 Rigidity 35, 37
 Rolling 15
 Rolling elements 6, 8

S
 Seal 70
 Two-lip version 42, 70, 86
 Sealing option 70
 End seal 70
 Length of the carriage 72
 Inner seal 70
 Combinations 71
 Metal scraper 70
 Side seal 70
 LFS 70
 MLS 70
 Sealing resistance 42
 Segmented guide rail 47, 115
 Selection criteria 13
 Service life time 14, 22, 35, 57
 Service life time calculation 16
 Special length 111
 Standards 14, 82
 Standard length 47, 110
 Static safety 14
 Static load rating 13
 Surface pressure 5, 8
 Stick-slip effect 41

T
 Temperature factor 18
 Tribo-corrosion 60
 Torque load 15, 37
 Type code
 Profile rail 112
 Carriage 112
 Linear guide system 112

W
 Wear 57

Y
 Yawing 15

More information concerning our NTN-SNR products for linear motion is provided in our catalogues.



NTN-SNR Linear Motion
Linear modules



NTN-SNR Linear Motion
Ball screws



NTN-SNR Linear Motion
Ball bushings



NTN-SNR Linear Motion
Ball splines



NTN-SNR Linear Motion
Linear axis news



ALMOTION



**WE GET
YOU MOVING!**

ALMOTION B.V.

Nijverheidsweg 14

6662 NG Elst (Gld)

The Netherlands

t +31(0)85 0491 777

e info@almotion.nl

www.almotion.nl

www.lineairegeleiding.nl

www.lineairegeleidingshop.nl

www.linearmotion.nl

