

7.8 LGBXH...B / LGBXX...B

Linear guide without ball chain, carriages in block design, normal / medium design height

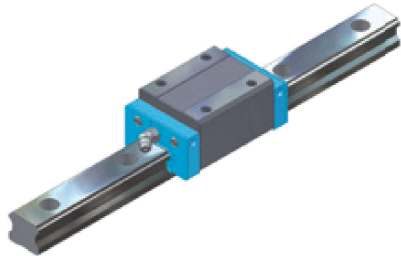

LGBXH / LGBXX...BN, standard

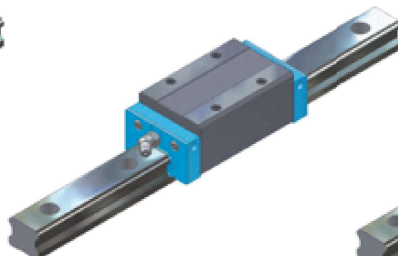

LGBXH / LGBXX...BL, long

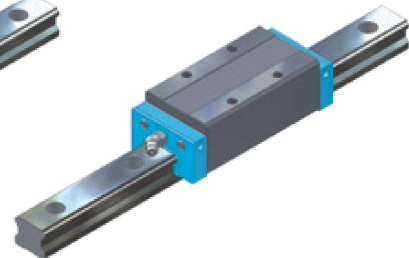

LGBXH / LGBXX...BE, extra long

Example of order code

LGBXH 25 BN 2 SS L 02000 N Z1 - 2 - 0 -20.0 N*

*Explanation to type code in Chapter 8

		System mm					Carriage mm											
		H	W	W2	E	L	B	J	MQ	I	L1	H2	T1	N	T2	L2	H3	Lx
LGBXH15	BN	28	34	9,5	3,4	58,6	26	26	M 4	6,0	40,2	M 3 x 0,5	9,5	5,7	8,5	4,20	M 3 x 0,5	3,0
LGBXH20	BN	30	44	12,0	4,5	70,1	32	36	M 5	6,5	48,5	M 6 x 1,0	7,1	12,3	6,3	4,25	M 6 x 1,0	3,8
LGBXH20	BL	30	44	12,0	4,5	82,9	32	36	M 5	6,5	61,3	M 6 x 1,0	7,1	12,3	6,3	4,25	M 6 x 1,0	3,8
LGBXH20	BE	30	44	12,0	4,5	98,13	32	50	M 5	6,5	76,5	M 6 x 1,0	7,1	12,3	6,3	4,25	M 6 x 1,0	3,8
LGBXX25	BN	36	48	12,5	5,8	79,2	35	35	M 6	9,0	57,5	M 6 x 1,0	10,2	12,2	9,4	4,65	M 6 x 1,0	5,0
LGBXX25	BL	36	48	12,5	5,8	93,9	35	35	M 6	9,0	72,2	M 6 x 1,0	10,2	12,2	9,4	4,65	M 6 x 1,0	5,0
LGBXX25	BE	36	48	12,5	5,8	108,6	35	50	M 6	9,0	86,9	M 6 x 1,0	10,2	12,2	9,4	4,65	M 6 x 1,0	5,0
LGBXH25	BN	40	48	12,5	5,8	79,2	35	35	M 6	9,0	57,5	M 6 x 1,0	14,2	12,2	13,4	4,65	M 6 x 1,0	5,0
LGBXH25	BL	40	48	12,5	5,8	93,9	35	35	M 6	9,0	72,2	M 6 x 1,0	14,2	12,2	13,4	4,65	M 6 x 1,0	5,0
LGBXH25	BE	40	48	12,5	5,8	108,6	35	50	M 6	9,0	86,9	M 6 x 1,0	14,2	12,2	13,4	4,65	M 6 x 1,0	5,0
LGBXH30	BN	45	60	16,0	7,0	94,8	40	40	M 8	12,0	67,8	M 6 x 1,0	13,0	11,7	8,5	6,00	M 6 x 1,0	5,0
LGBXH30	BL	45	60	16,0	7,0	105,0	40	40	M 8	12,0	78,0	M 6 x 1,0	13,0	11,7	8,5	6,00	M 6 x 1,0	5,0
LGBXH30	BE	45	60	16,0	7,0	130,5	40	60	M 8	12,0	103,5	M 6 x 1,0	13,0	11,7	8,5	6,00	M 6 x 1,0	5,0
LGBXH35	BN	55	70	18,0	7,5	111,5	50	50	M 8	12,0	80,5	M 6 x 1,0	18,5	11,5	13,5	7,25	M 6 x 1,0	5,0
LGBXH35	BL	55	70	18,0	7,5	123,5	50	50	M 8	12,0	92,5	M 6 x 1,0	18,5	11,5	13,5	7,25	M 6 x 1,0	5,0
LGBXH35	BE	55	70	18,0	7,5	153,5	50	72	M 8	12,0	122,5	M 6 x 1,0	18,5	11,5	13,5	7,25	M 6 x 1,0	5,0
LGBXH45	BN	70	86	20,5	8,9	129,0	60	60	M 10	18,0	94,0	M 8 x 1,25	24,5	10,8	24,5	8,00	M 8 x 1,25	7,5
LGBXH45	BL	70	86	20,5	8,9	145,0	60	60	M 10	18,0	110,0	M 8 x 1,25	24,5	10,8	24,5	8,00	M 8 x 1,25	7,5
LGBXH45	BE	70	86	20,5	8,9	174,0	60	80	M 10	18,0	139,0	M 8 x 1,25	24,5	10,8	24,5	8,00	M 8 x 1,25	7,5
LGBXH55	BN	80	100	23,5	12,7	155,0	75	75	M 12	22,0	116,0	M 8 x 1,25	24,0	10,8	24,5	10,00	M 8 x 1,25	7,5
LGBXH55	BL	80	100	23,5	12,7	193,0	75	75	M 12	22,0	154,0	M 8 x 1,25	24,0	10,8	24,5	10,00	M 8 x 1,25	7,5
LGBXH55	BE	80	100	23,5	12,7	210,0	75	95	M 12	22,0	171,0	M 8 x 1,25	24,0	10,8	24,5	10,00	M 8 x 1,25	7,5

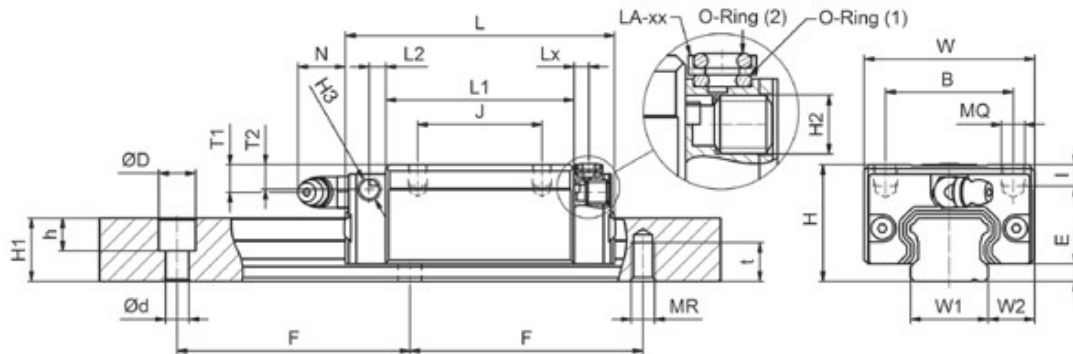
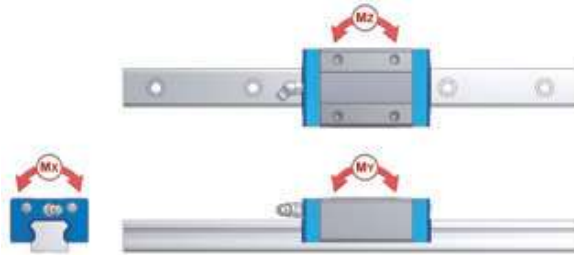

		Rail [mm]							Load rating					Mass			
		Version L					Version C		kN		kNm			kg	kg/ m		
W1	H1	F	d	D	h	MR	t	C	C0	MX	MY	MZ	Carriage	Rail			
15	13,0	60	4,5	7,5	5,5	M 5	8,0	9,46	19,90	0,137	0,120	0,120	0,19	1,28	LGBXH15	BN	
20	16,3	60	6,0	9,5	8,5	M 6	10,0	14,56	30,96	0,289	0,224	0,224	0,31	2,15	LGBXH20	BN	
20	16,3	60	6,0	9,5	8,5	M 6	10,0	18,88	40,11	0,376	0,366	0,366	0,36	2,15	LGBXH20	BL	
20	16,3	60	6,0	9,5	8,5	M 6	10,0	22,45	49,61	0,464	0,565	0,565	0,47	2,15	LGBXH20	BE	
23	19,2	60	7,0	11,0	9,0	M 6	12,0	20,44	41,73	0,447	0,358	0,358	0,40	2,88	LGBXX25	BN	
23	19,2	60	7,0	11,0	9,0	M 6	12,0	26,28	53,63	0,576	0,577	0,577	0,54	2,88	LGBXX25	BL	
23	19,2	60	7,0	11,0	9,0	M 6	12,0	29,63	64,30	0,691	0,833	0,833	0,67	2,88	LGBXX25	BE	
23	19,2	60	7,0	11,0	9,0	M 6	12,0	20,44	41,73	0,447	0,358	0,358	0,45	2,88	LGBXH25	BN	
23	19,2	60	7,0	11,0	9,0	M 6	12,0	26,28	53,63	0,576	0,577	0,577	0,66	2,88	LGBXH25	BL	
23	19,2	60	7,0	11,0	9,0	M 6	12,0	29,63	64,30	0,691	0,833	0,833	0,80	2,88	LGBXH25	BE	
28	22,8	80	9,0	14,0	12,0	M 8	15,0	30,24	55,50	0,719	0,560	0,560	0,91	4,45	LGBXH30	BN	
28	22,8	80	9,0	14,0	12,0	M 8	15,0	39,16	71,88	0,931	0,836	0,836	1,04	4,45	LGBXH30	BL	
28	22,8	80	9,0	14,0	12,0	M 8	15,0	43,60	88,18	1,142	1,361	1,361	1,36	4,45	LGBXH30	BE	
34	26,0	80	9,0	14,0	12,0	M 8	17,0	44,19	82,66	1,307	0,991	0,991	1,50	6,25	LGBXH35	BN	
34	26,0	80	9,0	14,0	12,0	M 8	17,0	53,96	103,29	1,633	1,424	1,424	1,80	6,25	LGBXH35	BL	
34	26,0	80	9,0	14,0	12,0	M 8	17,0	59,37	127,68	2,020	2,330	2,330	2,34	6,25	LGBXH35	BE	
45	31,1	105	14,0	20,0	17,0	M 12	20,0	59,25	111,30	2,353	1,559	1,559	2,28	9,60	LGBXH45	BN	
45	31,1	105	14,0	20,0	17,0	M 12	20,0	70,47	132,39	2,798	2,170	2,170	2,67	9,60	LGBXH45	BL	
45	31,1	105	14,0	20,0	17,0	M 12	20,0	81,42	166,87	3,527	3,455	3,455	3,35	9,60	LGBXH45	BE	
53	38,0	120	16,0	23,0	20,0	M 14	24,0	71,49	136,62	3,385	2,361	2,361	3,42	13,80	LGBXH55	BN	
53	38,0	120	16,0	23,0	20,0	M 14	24,0	96,46	183,14	4,538	4,202	4,202	4,57	13,80	LGBXH55	BL	
53	38,0	120	16,0	23,0	20,0	M 14	24,0	130,76	259,71	6,430	6,617	6,617	5,08	13,80	LGBXH55	BE	