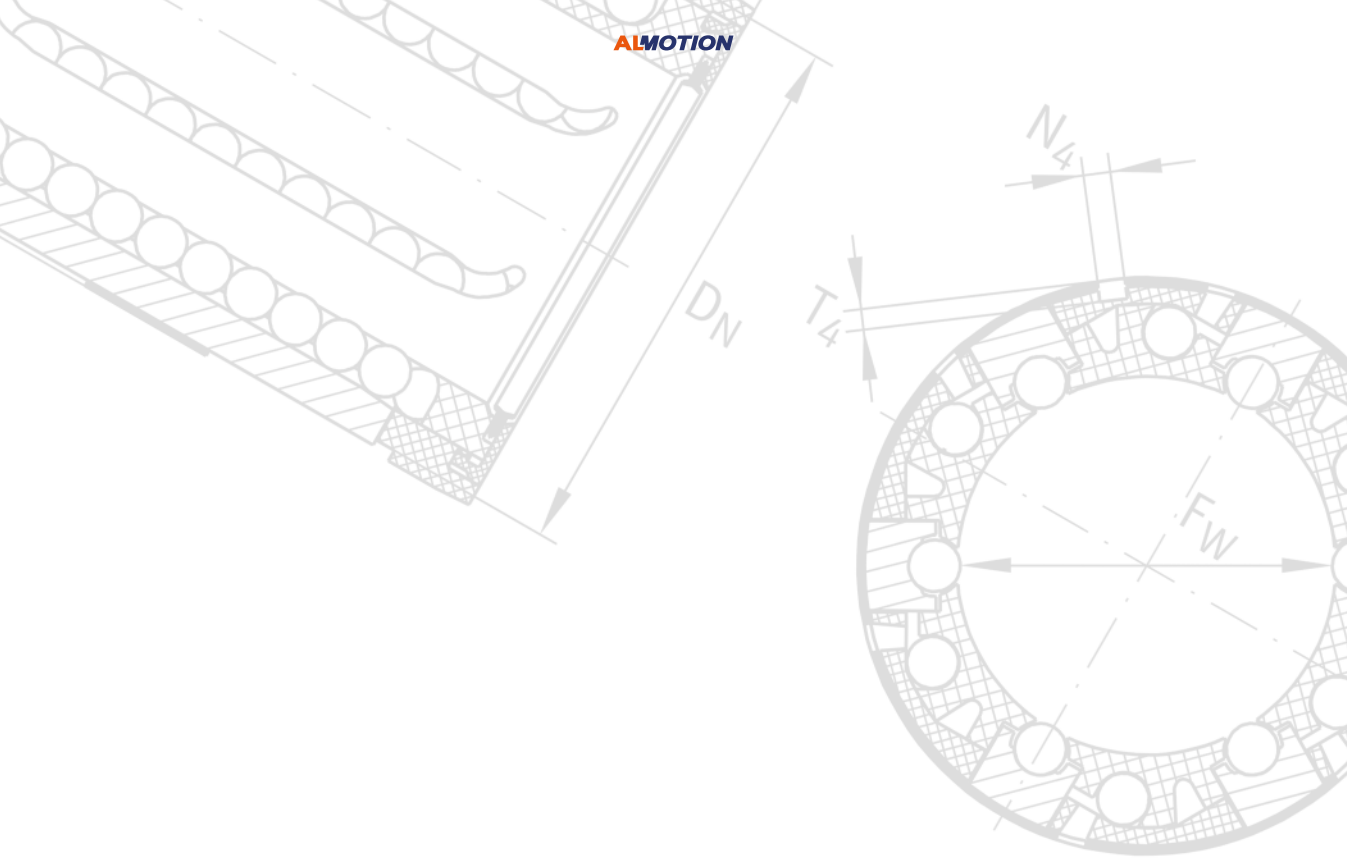


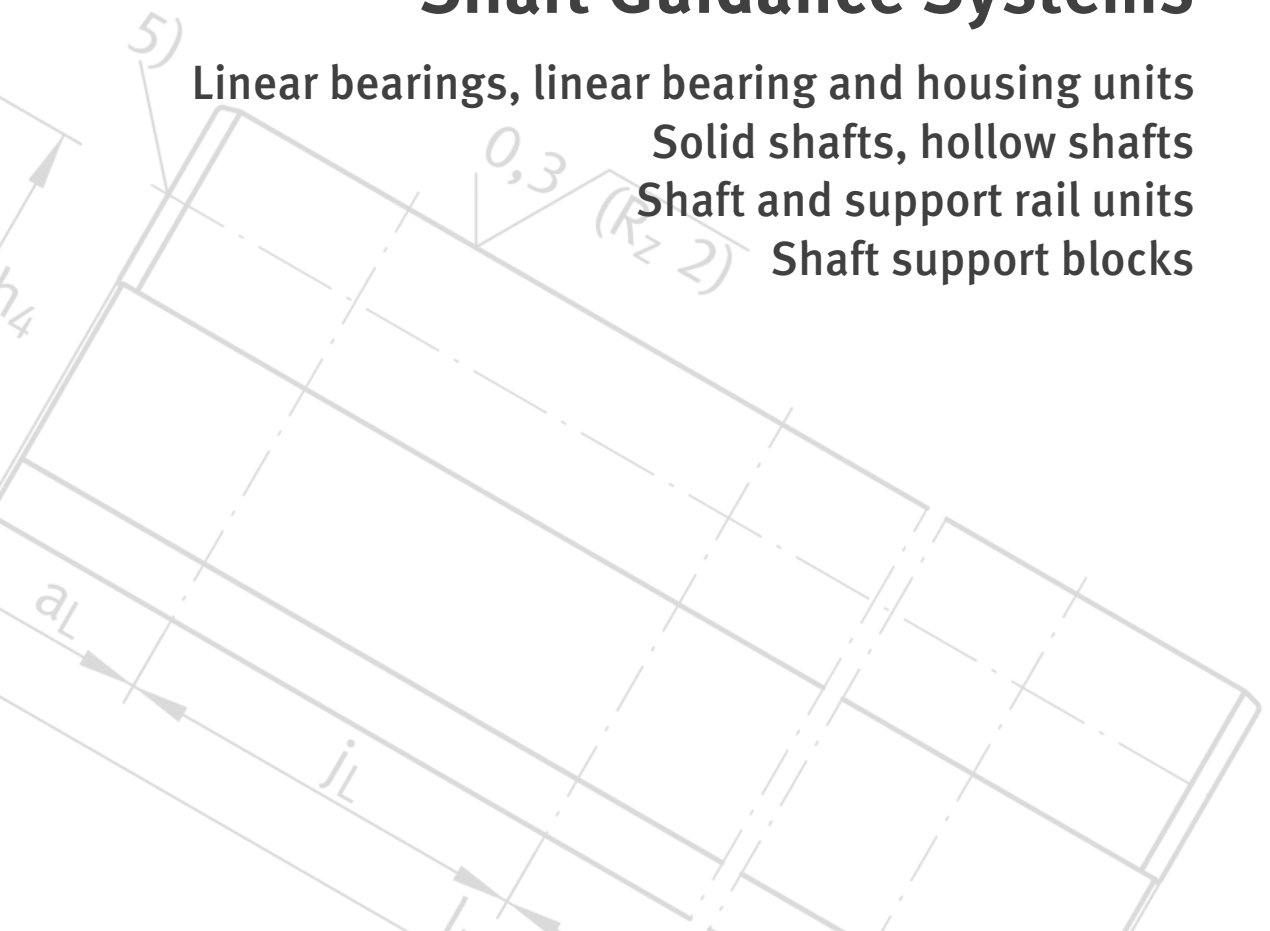
Shaft Guidance Systems

Linear bearings, linear bearing and housing units
Solid shafts, hollow shafts
Shaft and support rail units
Shaft support blocks



Shaft Guidance Systems

- Linear bearings, linear bearing and housing units
- Solid shafts, hollow shafts
- Shaft and support rail units
- Shaft support blocks



All data have been prepared with a great deal of care and checked for their accuracy but no liability can be accepted for any errors or omissions. We reserve the right to make technical modifications.

© Schaeffler Technologies GmbH & Co. KG
Issued: 2014, February

Reproduction in whole or in part without our authorisation is prohibited.

Foreword

Shaft guidance systems comprise shafts or shaft and support rail units combined with low-friction linear ball or plain bearings. The shafts can be either solid or hollow shafts, shaft and support rail units are always solid. For ease of fixing to the adjacent construction, the guidance systems are also available as complete linear bearing and housing units.

Economical due to modular concept

The complete range, structured according to a modular concept, allows particularly application-oriented, technically up-to-date and highly economical linear bearing guidance systems with a long, maintenance-free operating life.

Bearings and units are available in the compact, light, heavy duty, machined and plain bearing range. Each series has highly specific characteristics that precisely define it as suitable for particular applications.

Linear bearings

Linear ball bearings can support high radial loads while having a relatively low mass and allow the construction of linear guidance systems with unlimited travel. The bearings are available in closed versions and with a segment cutout for supported shafts. In some series, the radial clearance can be adjusted. This makes it possible to achieve clearance-free or preloaded guidance systems. Depending on the application, the linear bearings do not have seals or are fitted with contact seals on both sides.

Linear bearing and housing units

In the case of the linear bearing and housing units, the bearing is integrated in a strong, rigid housing. The housings are available in closed, open, slotted and tandem versions. Due to their low total mass, the units are particularly suitable for reduced mass designs with high loads and where higher accelerations and travel velocities are required. As a result of volume production in large quantities, the complete units are normally considerably more economical than customers' own designs.

Contents

	Page
Product index	6
Product overview	10
Shaft guidance systems	
Technical principles	12
Linear bearings, linear bearing and housing units	44
Solid shafts, hollow shafts	104
Shaft and support rail units	128
Shaft support blocks	144
Addresses	156

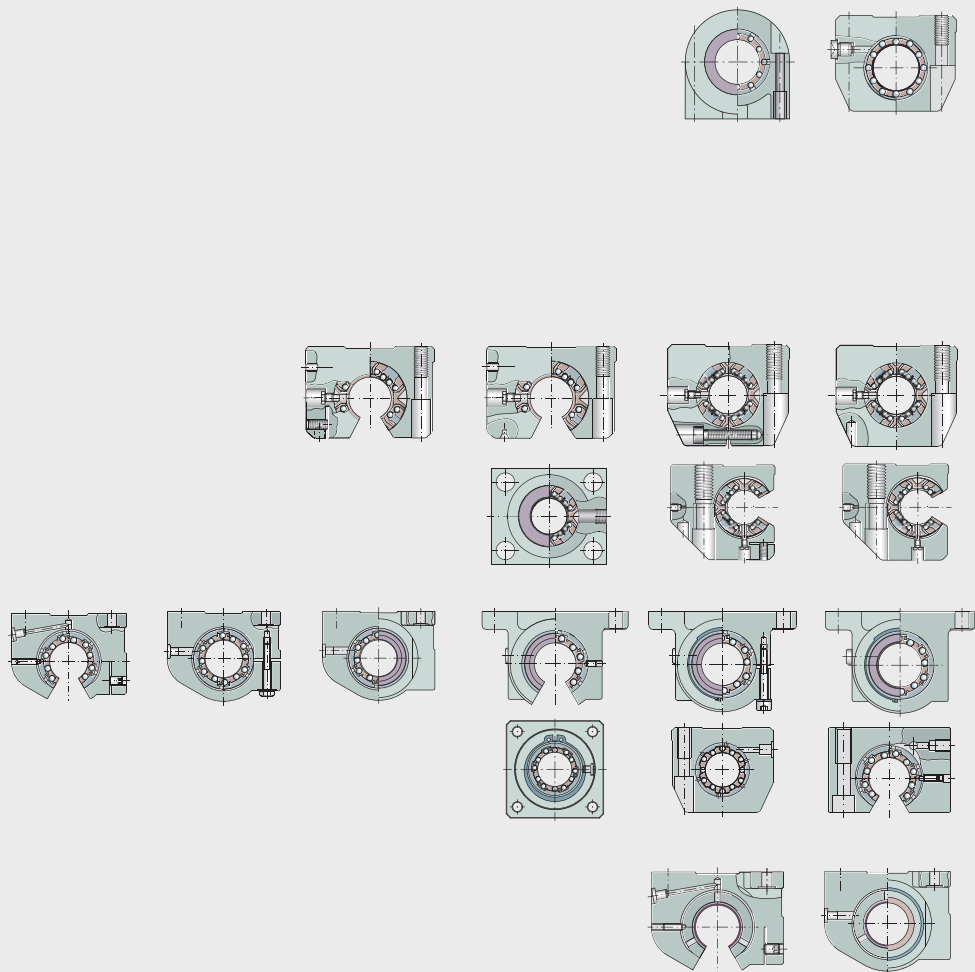
Product index

	Page
KH	Linear ball bearing, compact range..... 48
KGHA..-PP	Linear ball bearing and housing unit, compact range, closed, sealed 48
KGHK..-B-PP-AS	Linear ball bearing and housing unit, compact range, closed, sealed, relubrication facility 48
KTHK..-B-PP-AS	Linear ball bearing and housing unit, compact range, closed, bearings in tandem arrangement, sealed, relubrication facility 48
KN..-B	Linear ball bearing, light range, closed, self-aligning..... 48
KNO..-B	Linear ball bearing, light range, segment cutout, self-aligning 48
KS	Linear ball bearing, heavy duty range, closed, self-aligning..... 49
KSO	Linear ball bearing, heavy duty range, segment cutout, self-aligning 49
KGSC..-PP-AS	Linear ball bearing and housing unit, heavy duty range, segment cutout, sealed, relubrication facility 49
KGSCS..-PP-AS	Linear ball bearing and housing unit, heavy duty range, segment cutout, slotted housing, sealed, relubrication facility 49
KGSNG..-PP-AS	Linear ball bearing and housing unit, heavy duty range, closed, sealed, relubrication facility 49
KGSNO..-PP-AS	Linear ball bearing and housing unit, heavy duty range, segment cutout, sealed, relubrication facility 49
KGSNOS..-PP-AS	Linear ball bearing and housing unit, heavy duty range, segment cutout, slotted housing, sealed, relubrication facility 49
KGSNS..-PP-AS	Linear ball bearing and housing unit, heavy duty range, slotted housing, sealed, relubrication facility 49
KTFS	Linear ball bearing and housing unit, heavy duty range, closed, bearings in tandem arrangement, with centring collar, sealed, relubrication facility 49

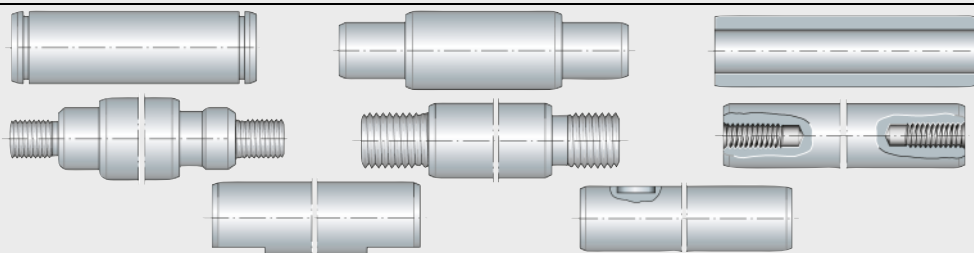
	Page
KTSG..-PP-AS	Linear ball bearing and housing unit, heavy duty range, closed, bearings in tandem arrangement, sealed, relubrication facility..... 49
KTSO..-PP-AS	Linear ball bearing and housing unit, heavy duty range, bearings in tandem arrangement, segment cutout, sealed, relubrication facility..... 49
KTSS..-PP-AS	Linear ball bearing and housing unit, heavy duty range, bearings in tandem arrangement, segment cutout, slotted housing, sealed, relubrication facility 49
KTSS..-PP-AS	Linear ball bearing and housing unit, heavy duty range, closed, bearings in tandem arrangement, slotted housing, sealed, relubrication facility 49
KB	Linear ball bearing, machined range, closed 50
KBO	Linear ball bearing, machined range, closed, segment cutout..... 50
KBS	Linear ball bearing, machined range, slotted 50
KFB...-B-PP-AS	Linear ball bearing and housing unit, machined range, closed, with flange, sealed, relubrication facility..... 51
KGB..-PP-AS	Linear ball bearing and housing unit, machined range, closed, sealed, relubrication facility..... 50
KGBA..-PP-AS	Linear ball bearing and housing unit, machined range, closed, sealed, relubrication facility..... 50
KGBAO..-PP-AS	Linear ball bearing and housing unit, machined range, segment cutout, sealed, relubrication facility 50
KGBAS..-PP-AS	Linear ball bearing and housing unit, machined range, slotted housing, sealed, relubrication facility 50
KGBO..-PP-AS	Linear ball bearing and housing unit, machined range, segment cutout, sealed, relubrication facility 50
KGBS..-PP-AS	Linear ball bearing and housing unit, machined range, slotted housing, sealed, relubrication facility 50

Product index

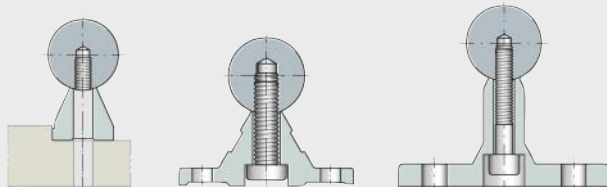
	Page
KTB..-PP-AS	Linear ball bearing and housing unit, machined range, closed, bearings in tandem arrangement, sealed, relubrication facility 50
KTBO..-PP-AS	Linear ball bearing and housing unit, machined range, segment cutout, bearings in tandem arrangement, sealed, relubrication facility 50
PAB..-PP-AS	Linear plain bearing, plain bearing range, closed, sealed, relubrication facility 51
PABO..-PP-AS	Linear plain bearing, plain bearing range, segment cutout, sealed, relubrication facility 51
PAGBA..-PP-AS	Linear plain bearing and housing unit, plain bearing range, closed, sealed, relubrication facility 51
PAGBAO..-PP-AS	Linear plain bearing and housing unit, plain bearing range, segment cutout, sealed, relubrication facility 51
W	Solid shafts 108
WH	Hollow shafts 108
TSNW	Shaft and support rail unit for fixing from above 132
TSNW..-G4	Shaft and support rail unit for fixing from above 132
TSNW..-G5	Shaft and support rail unit for fixing from above 132
TSUW	Shaft and support rail unit for fixing from below 132
TSWW	Shaft and support rail unit for fixing from above 132
TSWWA	Shaft and support rail unit for fixing from above 132
FW..-B	Shaft support block with flange 148
GW	Shaft support block 148
GWA..-B	Shaft support block 148
GWH..-B	Shaft support block 148
GWN..-B	Shaft support block 148



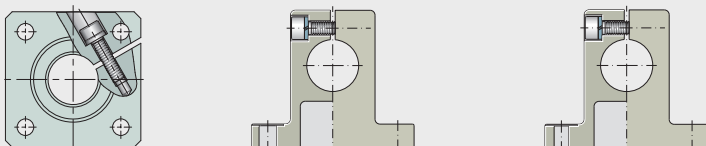
00019C1E



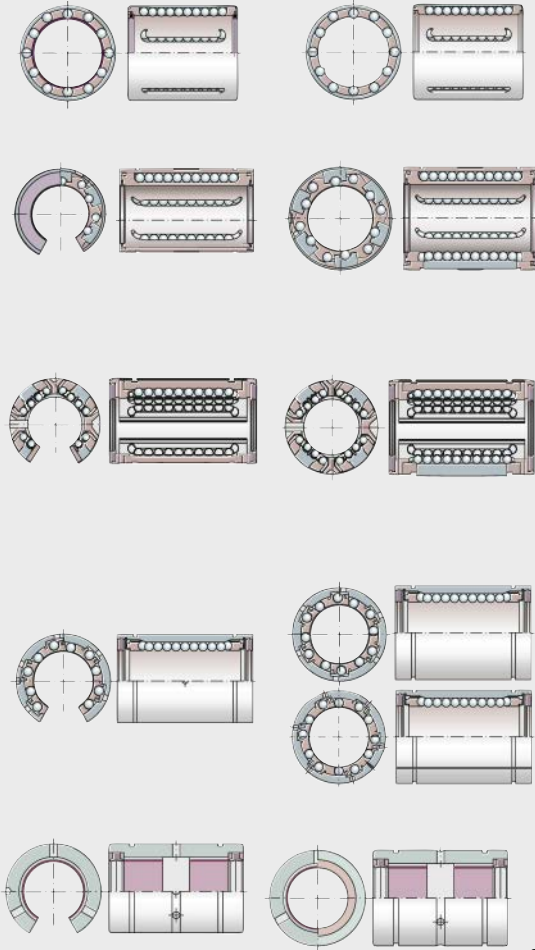
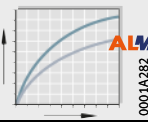
120 586



00019C1F



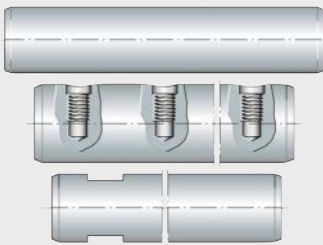
0007FCF2



00019CE0

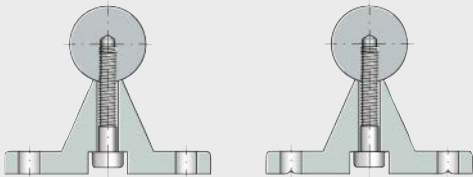
**Linear bearings,
linear bearing and housing units**

- Compact range
- Light range
- Heavy duty range
- Machined range
- Plain bearing range



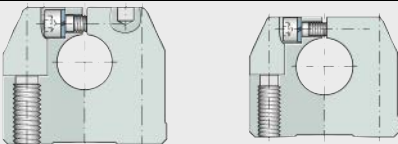
120 585

**Solid shafts
Hollow shafts**



120 587

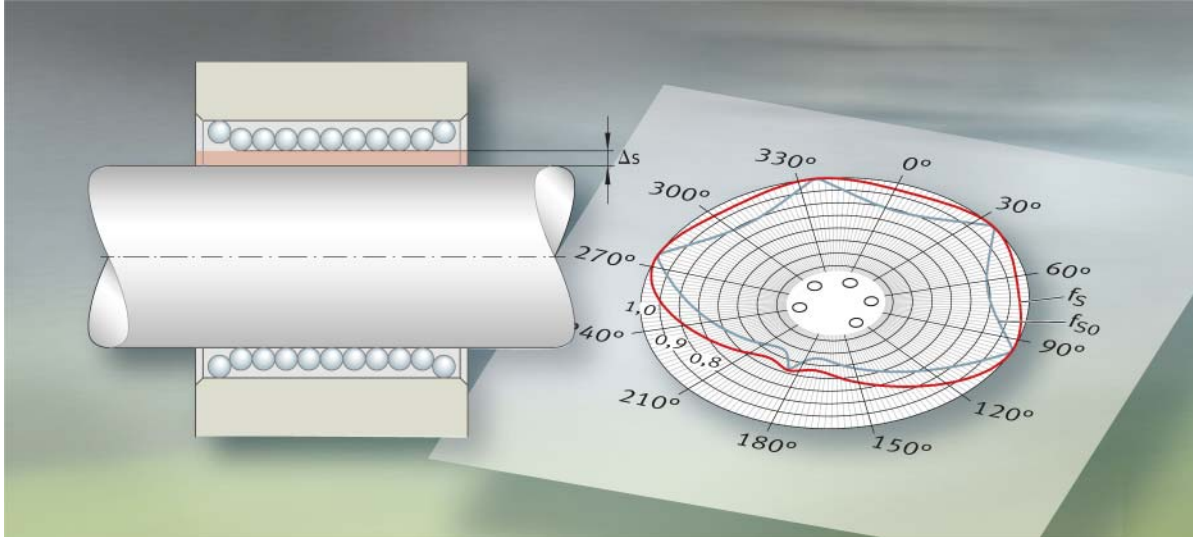
Shaft and support rail units



120 589

Shaft support blocks





Technical principles

- Load carrying capacity and life
- Friction
- Lubrication
- Design of bearing arrangements
- Operating clearance
- Fitting



Technical principles

	Page	
Load carrying capacity and life	Basic rating life	15
	Operating life	16
	Static load safety factor	16
	Influence of the shaft raceway on basic load ratings	17
	Differences in raceway hardness	17
	Load direction and position of the ball rows	18
	Main load direction	18
	Linear ball bearings	19
	Linear ball bearing and housing units	19
	Misalignment of the shaft	25
	Load factors in misalignment	25
	Compensation of misalignments in the light and heavy duty range	26
	Friction	Coefficient of friction
Coefficient of friction in unsealed bearings		27
Lubrication	Grease lubrication	28
	Structure of suitable greases	28
	Initial greasing and operating life	28
	Relubrication of linear ball bearings in housings	29
	Lubrication nipples for housings	30
	Application in special environments	32
	Oil lubrication	32
	Suitable oils	32
Design of bearing arrangements	Location	33
	Linear ball bearings KH	33
	Linear ball bearings KN..-B, KB, KS and plain bearings PAB	33
	Linear ball bearings KNO..-B, KBO and plain bearings PABO	34
	Linear ball bearing and housing units	35
	Sealing	36
	Gap seals or contact seals	36

Technical principles

	Page
Operating clearance	
Tolerance and operating clearance	37
Mounting tolerances and operating clearance	38
Mounting	
Mounting of bearings	39
Linear ball bearings KH	39
Linear ball bearings KN..-B, KNO..-B, KB, KBS, KBO, KS, KSO and linear plain bearings PAB, PABO	40
Alignment of bearings and shafts	41
Bearings arranged in series	41
Bearings arranged in parallel	41
Very long guidance systems with supported shaft	42
Guidance systems with clearance-free or preloaded bearings	42
Parallel shaft and support rail units	42
Setting the operating clearance	43
Setting bearings clearance-free	43
Setting the preload	43
Suspended arrangement of guidance system	43



Load carrying capacity and life

The size of a linear ball bearing is determined by the demands made in terms of load carrying capacity, rating life and operational security.

The load carrying capacity is described in terms of:

- the basic dynamic load rating C
- the basic static load rating C_0 .

The calculation of the basic dynamic and static load ratings given in the dimension tables is based on DIN 636-1.

Basic rating life

The basic rating life L is reached or exceeded by 90 % of a sufficiently large group of apparently identical bearings before the first evidence of material fatigue occurs.

$$L = \left(\frac{C}{P} \right)^3$$

$$L_h = \frac{833}{H \cdot n_{osc}} \cdot \left(\frac{C}{P} \right)^3$$

$$L_h = \frac{1666}{\bar{v}} \cdot \left(\frac{C}{P} \right)^3$$

L	m
Basic rating life L in 100 000 m	
C	N
Basic dynamic load rating	
P	N
Equivalent dynamic bearing load	
L_h	h
Basic rating life in operating hours	
H	m
Single stroke length	
n_{osc}	min^{-1}
Number of return strokes per minute	
\bar{v}	m/min
Mean travel velocity.	

Load carrying capacity and life

Operating life

The operating life is defined as the life actually achieved by a shaft guidance system. It may differ significantly from the calculated life.

The following influences can lead to premature failure through wear or fatigue:

- misalignment between the guideways and guidance elements
- contamination
- inadequate lubrication
- reciprocating motion with very small stroke length (false brinelling)
- vibration during stoppage (false brinelling).

Due to the wide variety of mounting and operating conditions, it is not possible to precisely predetermine the operating life of a shaft guidance system. The safest way to arrive at an appropriate estimate of the operating life is comparison with similar applications.

Static load safety factor

The static load safety factor S_0 indicates the security against impermissible permanent deformations in the bearing and is determined by means of the following equation.

$$S_0 = \frac{C_0}{P_0}$$

S_0 –
Static load safety factor

C_0 N
Basic static load rating

P_0 N
Equivalent static load.



For linear ball bearings KH and KN..-B, the value must be $S_0 \geq 4$.

In relation to guidance accuracy and smooth running, a value of $S_0 \geq 2$ is regarded as permissible. If $S_0 < 2$, please contact us.



Influence of the shaft raceway on the basic load ratings

The basic load ratings in the dimension tables are only valid if a ground (Ra 0,3) and hardened shaft (at least 670 HV) is provided as a raceway.

Differences in raceway hardness

If shafts with a surface hardness lower than 670 HV are used (for example, shafts made from X46 or X90), a hardness factor must be applied, see equations and *Figure 1*.

$$C_H = f_H \cdot C$$

$$C_{OH} = f_{H0} \cdot C_0$$

- C_H N
Effective dynamic load rating
- f_H -
Dynamic hardness factor, *Figure 1*
- C N
Basic dynamic load rating
- C_{OH} N
Effective static load rating
- f_{H0} -
Static hardness factor, *Figure 1*
- C_0 N
Basic static load rating.

f_{H0} = static hardness factor
 f_H = dynamic hardness factor
 HV, HRC = surface hardness

- ① X90
- ② X46

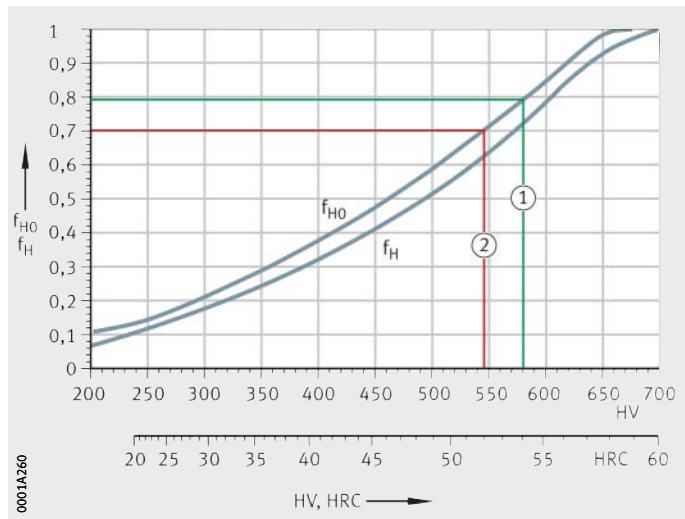


Figure 1
 Static and dynamic hardness factors for lower hardness of raceways

Load carrying capacity and life

Load direction and orientation of the ball rows

The effective load rating of a linear ball bearing is dependent on the position of the load direction in relation to the position of the ball rows:

- The lowest load rating C_{min} and $C_{0 min}$ occurs at the zenith position, *Figure 2*.
- The highest load rating C_{max} and $C_{0 max}$ occurs at the symmetrical position, *Figure 2*.

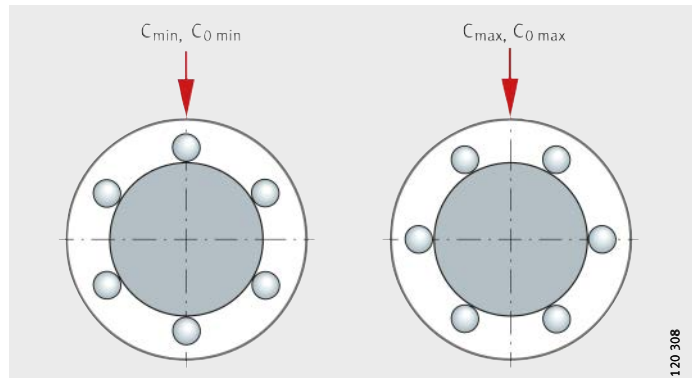
If the bearings are mounted in correct alignment, the maximum load rating can be used. If aligned mounting is not possible or the direction of loading is not defined, the minimum load ratings must be assumed.

Main load direction

For linear ball bearings and linear ball bearing and housing units where the mounting position of the ball rows is defined, the basic load ratings C and C_0 in the main load direction are given, *Figure 3*. For other load directions, the effective load ratings can be determined using the load direction factors in *Figure 4*, page 20, to *Figure 21*, page 24.

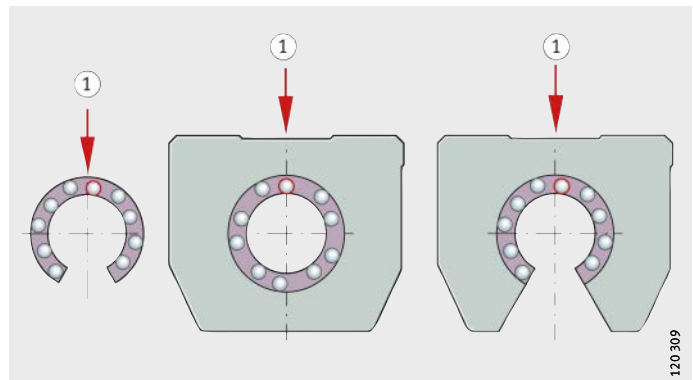
If the mounting position of the ball rows is not defined, the minimum basic load ratings are stated.

Figure 2
Load carrying capacity, dependent on the position of the ball rows



① Main load direction

Figure 3
Main load direction for bearings and housing units





Linear ball bearings

The basic load ratings given in the dimension tables are defined as follows:

- For KH, KN..-B, KS, KB and KBS, the minimum and maximum load ratings apply, *Figure 2*, page 18.
- For KNO..-B, KSO and KBO, the basic load ratings apply in the main load direction. In the case of other load directions, see *Figure 4*, page 20, to *Figure 13*, page 22.

Linear ball bearing and housing units

The basic load ratings given in the dimension tables are defined as follows:

Compact range

For the units KGHK, KTHK, the minimum load rating applies.

Heavy duty range

For the heavy duty range, the basic load rating applies in the main load direction. In the case of other load directions, see *Figure 14* to *Figure 17*, page 23.

Machined range

For the units KGB, KGBA, KTB, KGBS, KGBAS, the minimum load rating applies.

For the open units KGBO, KGBAO, the basic load rating applies in the main load direction. In the case of other load directions, see *Figure 20* to *Figure 21*, page 24.

Load direction factors

The factors in *Figure 4*, page 20, to *Figure 13*, page 22, are applied as follows:

$$C_w = f_s \cdot C$$

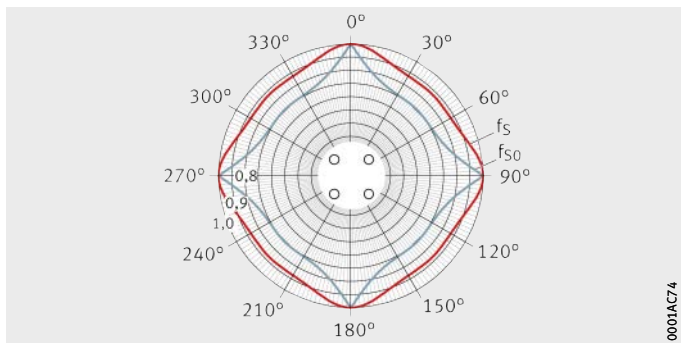
C_w N
Effective dynamic load carrying capacity
 f_s –
Dynamic load factor for load direction
 C N
Basic dynamic load rating.

$$C_{0w} = f_{S0} \cdot C_0$$

C_{0w} N
Effective static load carrying capacity
 f_{S0} –
Static load factor for load direction
 C_0 N
Basic static load rating.

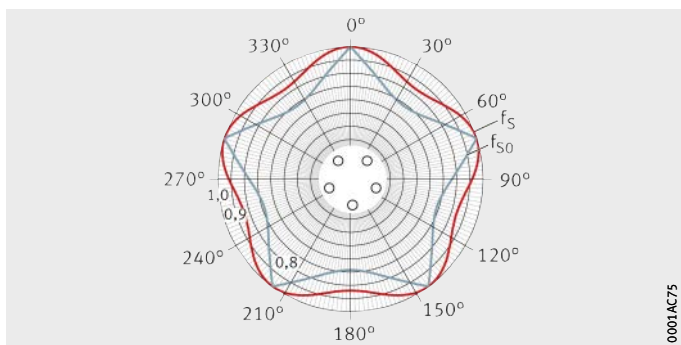
Load carrying capacity and life

Figure 4
Compact range
 Load direction factor
 for KH06, KH08, KH10



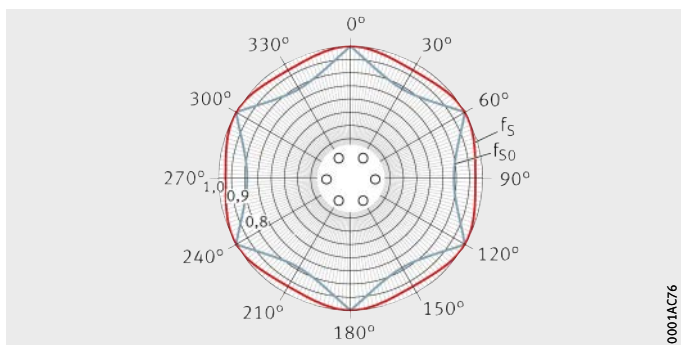
0001AC74

Figure 5
Compact range
 Load direction factor
 for KH12, KH14, KH16



0001AC75

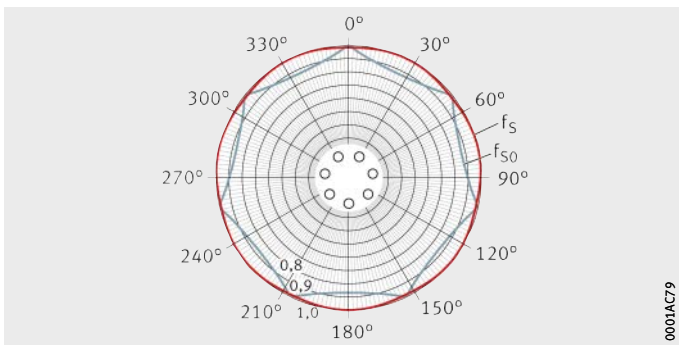
Figure 6
Compact range
 Load direction factor
 for KH20, KH25



0001AC76

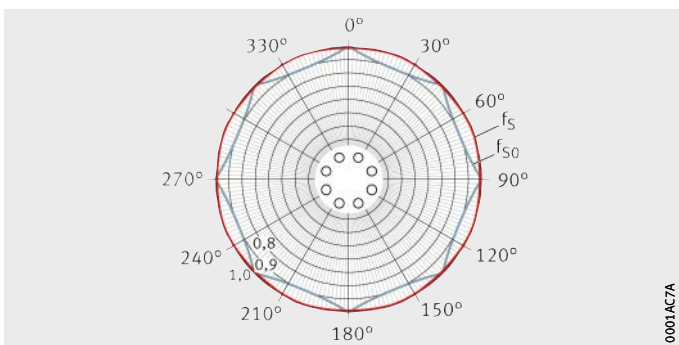


Figure 7
Compact range
 Load direction factor
 for KH30



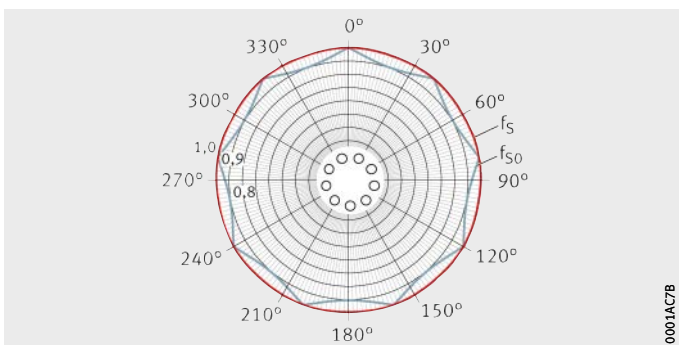
0001AC79

Figure 8
Compact range
 Load direction factor
 for KH40



0001AC7A

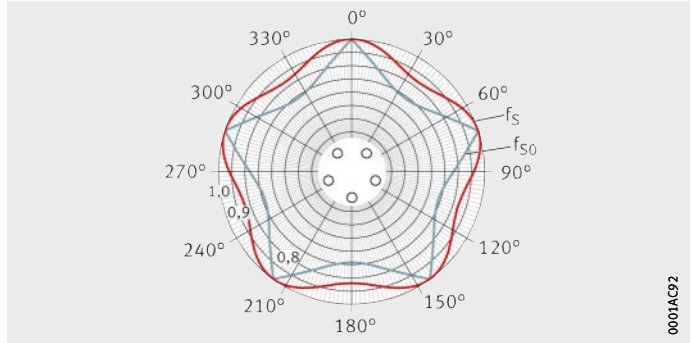
Figure 9
Compact range
 Load direction factor
 for KH50



0001AC7B

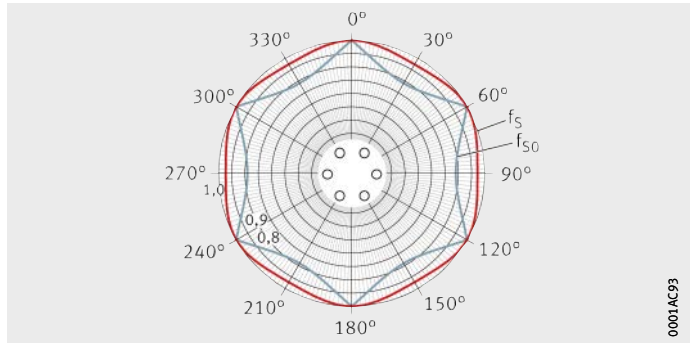
Load carrying capacity and life

Figure 10
Light range
 Load direction factor
 for KN12-B, KN16-B



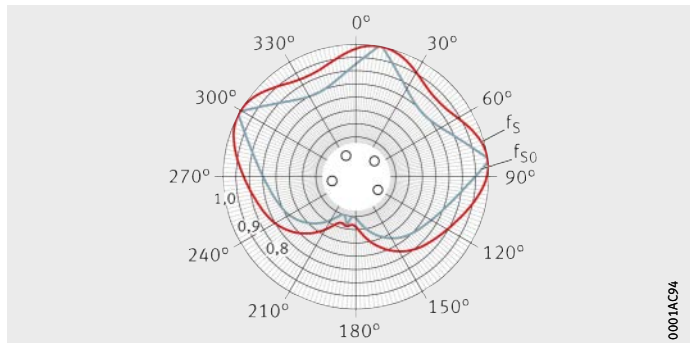
0001AC92

Figure 11
Light range
 Load direction factor
 for KN20-B, KN25-B,
 KN30-B, KN40-B, KN50-B



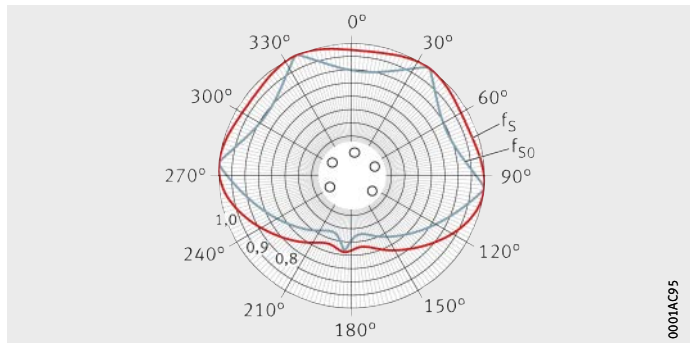
0001AC93

Figure 12
Light range
 Load direction factor
 for KNO12-B, KNO16-B



0001AC94

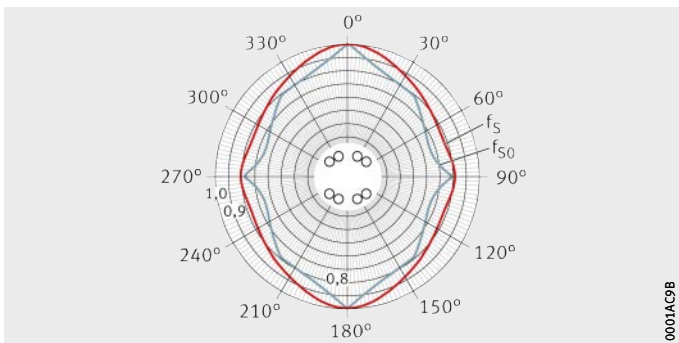
Figure 13
Light range
 Load direction factor
 for KNO20-B, KNO25-B,
 KNO30-B, KNO40-B, KNO50-B



0001AC95

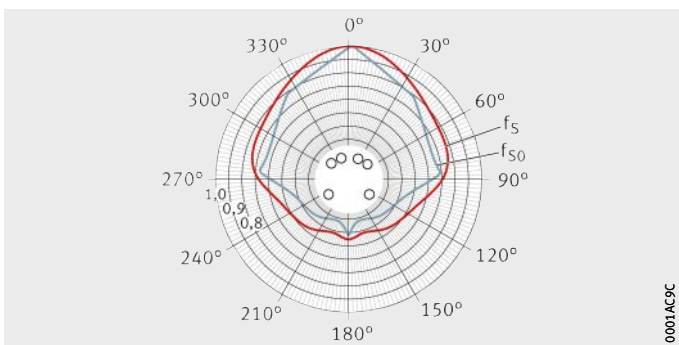


Figure 14
Heavy duty range
 Load direction factor
 for KS12, KS16, KS20, KS25,
 KS30, KS40, KS50



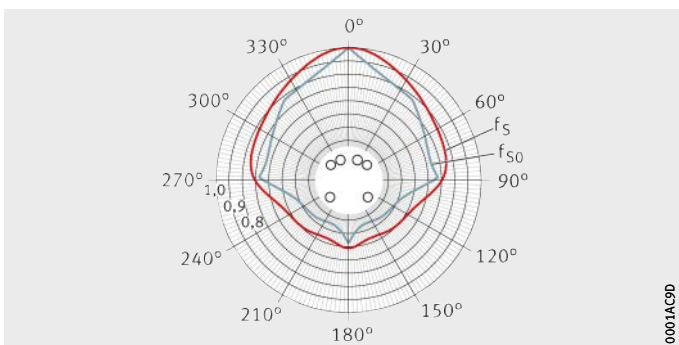
0001AC9B

Figure 15
Heavy duty range
 Load direction factor
 for KS012, KS016



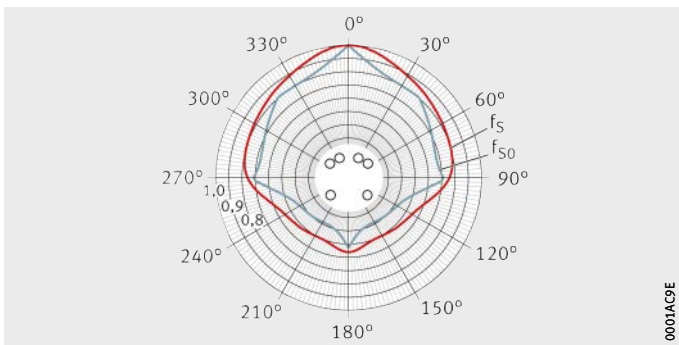
0001AC9C

Figure 16
Heavy duty range
 Load direction factor
 for KS020, KS025



0001AC9D

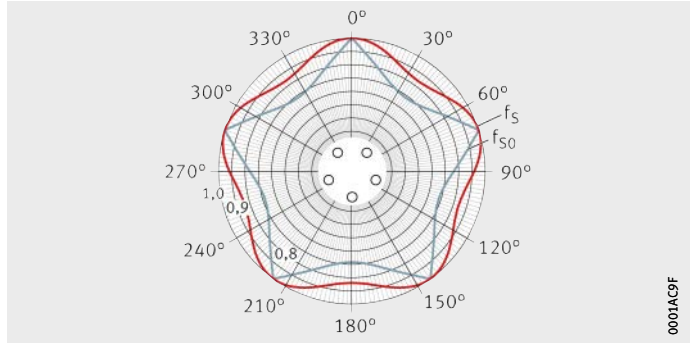
Figure 17
Heavy duty range
 Load direction factor
 for KS030, KS040, KS050



0001AC9E

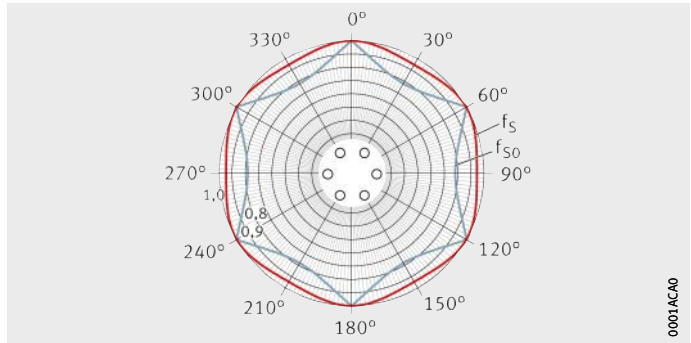
Load carrying capacity and life

Figure 18
Machined range
 Load direction factor
 for KB12, KB16



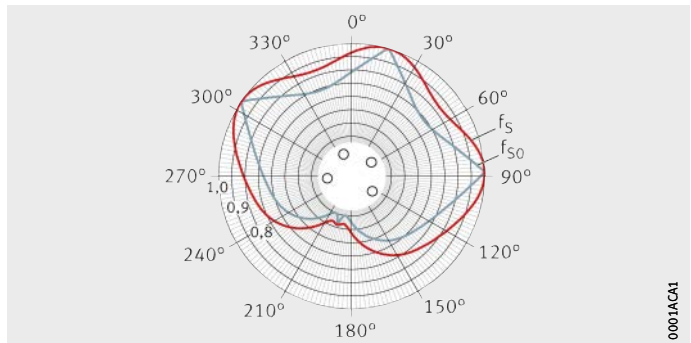
0001AC0F

Figure 19
Machined range
 Load direction factor
 for KB20, KB25,
 KB30, KB40, KB50



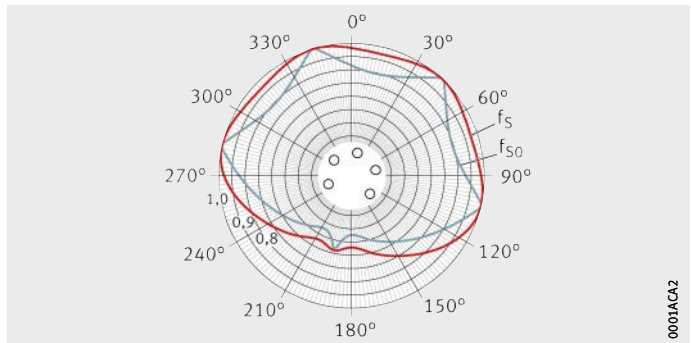
0001AC40

Figure 20
Machined range
 Load direction factor
 for KBO12, KBO16



0001AC41

Figure 21
Machined range
 Load direction factor
 for KBO20, KBO25,
 KBO30, KBO40, KBO50



0001AC42



Misalignment of the shaft

Misalignment of the shaft impairs the running quality and operating life of linear ball bearings. Guidance systems with one shaft should therefore have at least two bearings, while guidance systems with two shafts should have at least three bearings.

Load factors in misalignment

Due to shaft flexing, it is not always possible to avoid misalignment, *Figure 22*. If it is present, load factors for misalignment should be applied, *Figure 23* and *Figure 24*, page 26.

$$P = K_F \cdot F_r$$

$$P_0 = K_{F0} \cdot F_r$$

P, P ₀	N
Equivalent dynamic or static load	
K _F , K _{F0}	–
Dynamic or static load factor for misalignment, <i>Figure 23</i> or <i>Figure 24</i> , page 26	
F _r	N
Maximum radial bearing load	
C, C ₀	N
Basic radial dynamic or static load rating, <i>Figure 23</i> or <i>Figure 24</i> , page 26.	

F_r = radial load
 φ = misalignment

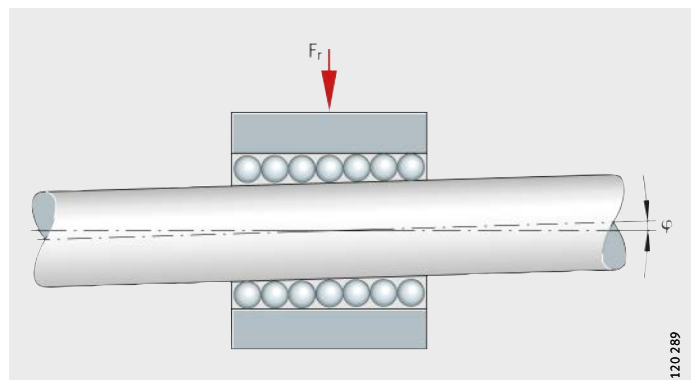


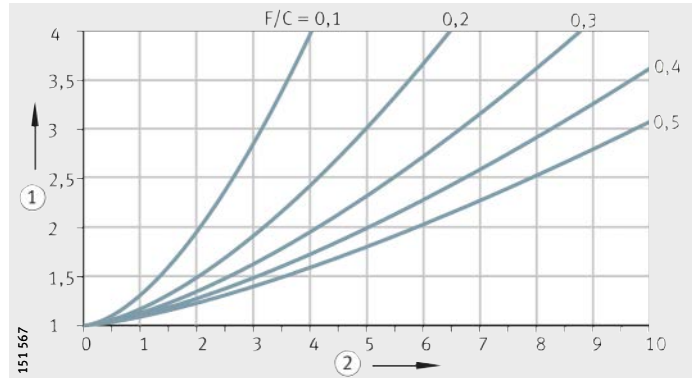
Figure 22
 Misalignment φ of the shaft

120 289

Load carrying capacity and life

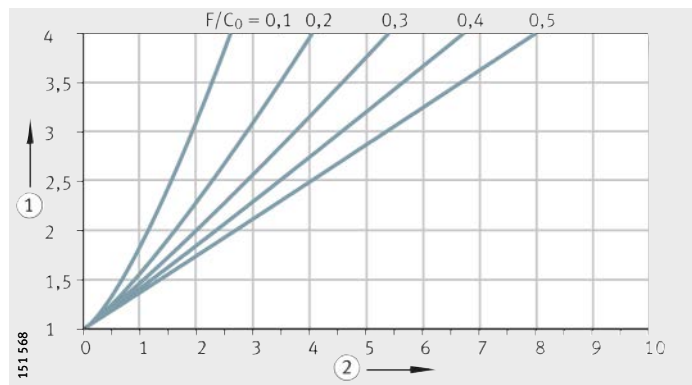
- ① Dynamic load factor K_F
- ② Misalignment φ in angular minutes

Figure 23
Dynamic load factor
for shaft misalignment



- ① Static load factor K_{F0}
- ② Misalignment φ in angular minutes

Figure 24
Static load factor
for shaft misalignment



Compensation of misalignments in the light and heavy duty range

Linear ball bearings KN..-B, KNO..-B, KS and KSO and linear ball bearing and housing units containing these bearings are self-aligning. They can compensate misalignments of up to ± 30 angular minutes (KN..-B and KNO..-B) or ± 40 angular minutes (KS and KSO) without detrimental effect on the load carrying capacity.



Friction

Linear ball bearings are frequently used where high positional accuracy and high efficiency are a priority. The bearings must therefore run without stick-slip and with only low friction.

The linear ball bearings KN...-B, KNO...-B, KS, KSO, KB, KBS, KBO have particularly low friction.

Coefficient of friction

The total friction consists of:

- rolling and sliding friction at the rolling contacts (sliding friction in linear plain bearings)
- friction in the return zones and recirculation guides
- lubricant friction
- seal friction.

The factors on which the coefficient of friction depends may act in a reciprocal manner, may act in a single direction or may counteract each other.

Coefficient of friction in unsealed bearings

The coefficients of friction for unsealed linear bearings with oil lubrication are given in the table.

In the case of linear plain bearings, the coefficient of friction is between 0,02 and 0,2.

Series and coefficient of friction

Series	Coefficient of friction
KH	0,003 – 0,005
KN...-B, KNO...-B	0,001 – 0,0025
KS, KSO	0,001 – 0,0025
KB, KBS, KBO	0,001 – 0,0025

Lubrication

Open linear ball bearings are supplied with a wet or dry preservative and can be lubricated using either grease or oil. The oil-based preservative is compatible and miscible with lubricants with a mineral oil base, which means that it is not generally necessary to wash out the bearings before mounting.

Bearings with a dry preservative must be greased or oiled immediately after they are removed from the packaging.

Grease lubrication

Grease lubrication should be used in preference to oil lubrication, since the grease adheres to the inside of the bearing and thus prevents the ingress of contamination. This sealing effect protects the rolling elements against corrosion.

In addition, the design work involved in providing grease lubrication is less than that for providing oil, since design of the sealing arrangement is less demanding.

Composition of suitable greases

The greases for linear ball bearings have the following composition:

- lithium or lithium complex soap
- base oil: mineral oil or poly-alpha-olefin (PAO)
- special anti-wear additives for loads $C/P < 8$, indicated by "P" in the DIN designation KP2K-30
- consistency to NLGI grade 2 in accordance with DIN 51818.

Initial greasing and operating life

Based on experience, the operating life is achieved when bearings are operated with grease lubrication in normal environmental conditions ($C/P > 10$), at room temperature and at $v \leq 0,6 \cdot v_{\max}$. If it is not possible to achieve these conditions, the bearings must be relubricated.

Sealed linear ball bearings are already adequately greased when delivered and are therefore maintenance-free in many applications.

Initial greasing and relubrication of bearings

The initial greasing and relubrication of linear ball bearings without seals and relubrication holes must be carried out via the shaft. It must be ensured that all rolling elements come into contact with grease during recirculation. The bearing must be moved over at least twice its length during relubrication.

During initial greasing, the bearing fitted on the shaft should be fed with lubricant until this begins to emerge from the bearing.

In the case of the linear ball bearings KH, KN..-B-PP-AS, KS..-PP-AS and PAB..-PP-AS, relubrication can be carried out via holes or openings in the retaining ring or outer ring.



Relubrication interval

The relubrication interval is dependent on many operating conditions such as load, temperature, speed, stroke length, lubricant, environmental conditions and the mounting position.



Precise lubrication intervals should be determined by tests conducted under application conditions.

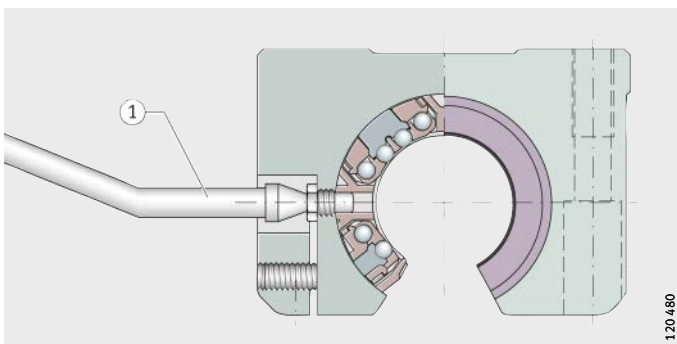
Relubrication of linear ball bearings in housings

If linear ball bearings are mounted in a housing, special nozzle tubes may be required for relubrication, *Figure 1* and *Figure 2*. Sources for nozzle tubes with suitable needle point heads can be requested from us.



Figure 1
Nozzle tube

120 591



① Nozzle tube

Figure 2
Relubrication using nozzle tube

120 480

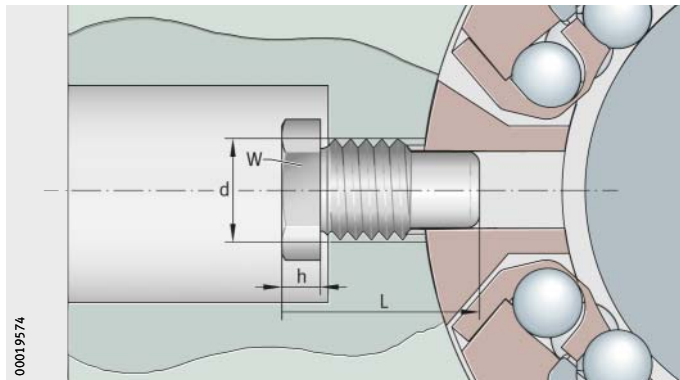
Lubrication

Lubrication nipples for housings

Lubrication nipples for housings with KS are shown in *Figure 3*, suitable DIN lubrication nipples for housings with KN...-B are shown in *Figure 4* and *Figure 5*, page 31, for other housings, see *Figure 6*, page 31. The dimensions are given in the tables.

NIP..MZ

Figure 3
Lubrication nipple for heavy duty range KS

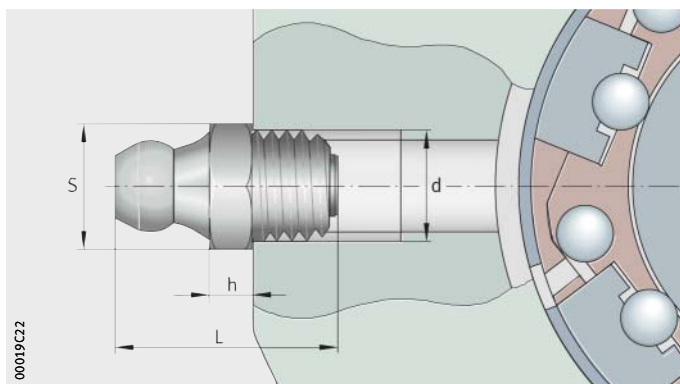


Lubrication nipples

Lubrication nipple	Width across flats W	Dimensions		
		d mm	L mm	h mm
NIP4MZ	5	M4	7,7	1,5
NIP5MZ	6	M5	11,1	2
NIP6MZ	7	M6	14,8	2,5

NIP DIN 71412

Figure 4
Lubrication nipple DIN 71412 type A for light range KN...-B



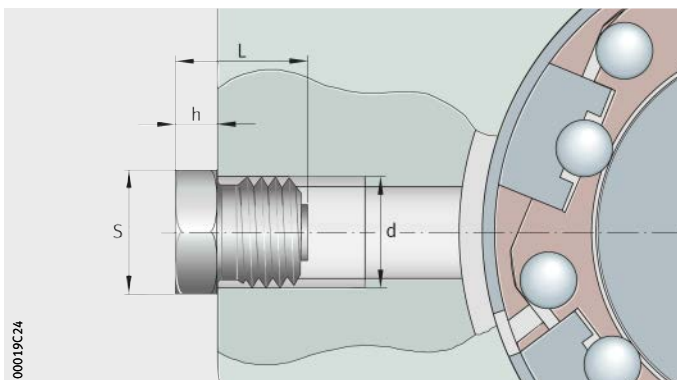
Taper type lubrication nipples

Taper type lubrication nipple	Dimensions			
	S h13 mm	d mm	L mm	h j16 mm
NIP DIN 71412-AM6	7	M6	16	3
NIP DIN 71412-AM8×1	9	M8×1	16	3



NIP DIN 3405

Figure 5
Alternative lubrication nipple DIN 3405 type A for light range KN...B

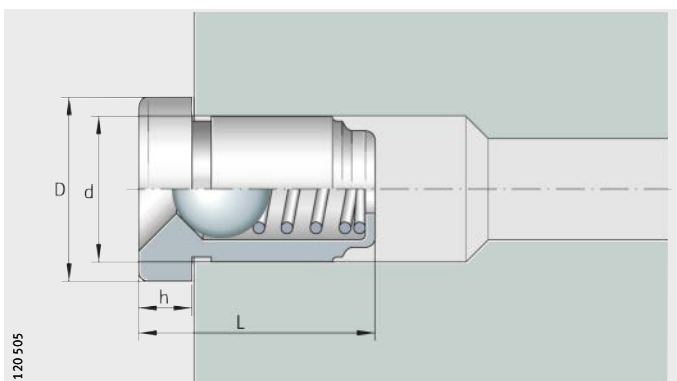


Funnel type lubrication nipples

Funnel type lubrication nipple	Dimensions			
	S h13 mm	d mm	L mm	h j16 mm
NIP DIN 3405-AM6	7	M6	9,5	3
NIP DIN 3405-AM8×1	9	M8×1	9,5	3

NIPA

Figure 6
Lubrication nipple for compact range KH, machined range KB, plain bearing range PAB



Lubrication nipples

Lubrication nipple	Dimensions			
	D mm	d mm	L mm	h mm
NIPA1	6	4	6	1,5
NIPA2	8	6	9	2

Lubrication

Application in special environments

In vacuum applications, lubricants with low vapourisation rates are required in order to maintain the vacuum atmosphere.

In the foodstuffs sector and clean rooms, special requirements are also placed on lubricants in relation to emissions and compatibility. For such environmental conditions, please consult us.

Oil lubrication

Oil lubrication should be used in preference if heat is to be dissipated and contaminants are to be carried out of the bearing by the lubricant.

This advantage should be set against the increased design work required (lubricant feed, sealing).

Suitable oils

As a function of the load case, we recommend the following oils:

- for low to moderate loads ($C/P > 15$):
 - hydraulic oils HL to DIN 51524 and oils CL to DIN 51517 in the viscosity range ISO-VG 10 to ISO-VG 22
- for high loads ($C/P < 8$):
 - hydraulic oils HLP to DIN 51524 and oils CLP to DIN 51517 in the viscosity range ISO-VG 68 to ISO-VG 100.



Design of bearing arrangements

The good running characteristics of shaft guidance systems are dependent not only on the bearings. The geometrical and positional tolerances of the adjacent construction also play a significant role. The higher the accuracy to which the adjacent construction is produced and assembled, the better the running characteristics.

Location

Linear ball bearings KH

Linear ball bearings KH and KH..-PP are pressed into the housing bore. This provides axial and radial location. No additional means of location are required.

Linear ball bearings KN..-B, KB, KS and plain bearings PAB

Linear ball bearings KN..-B, KB, KS and plain bearings PAB require axial location.

Linear ball bearings KB and plain bearings PAB can be located by means of retaining rings or by the adjacent construction, *Figure 1 to Figure 3*, page 34.

Linear ball bearings KN..-B and KS can be located in accordance with *Figure 2* and *Figure 3*, page 34.

Linear ball bearings KN..-B can also be located by means of a screw, *Figure 4*, page 34.



The series KN..-B and KS should not be located by means of shaft retaining rings according to *Figure 1*. This could impair the function of the bearing.

① Retaining rings

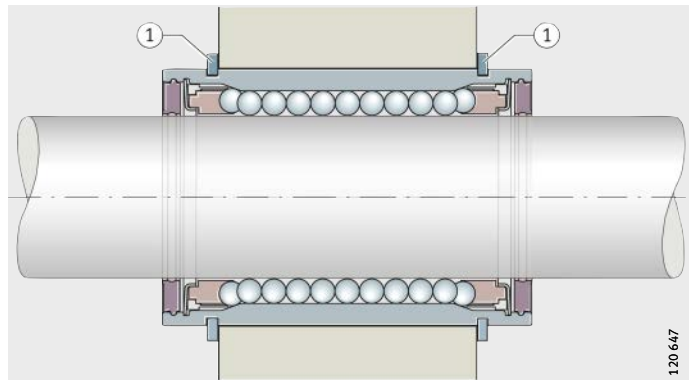


Figure 1
Retaining rings in the bearing slots

① Retaining rings

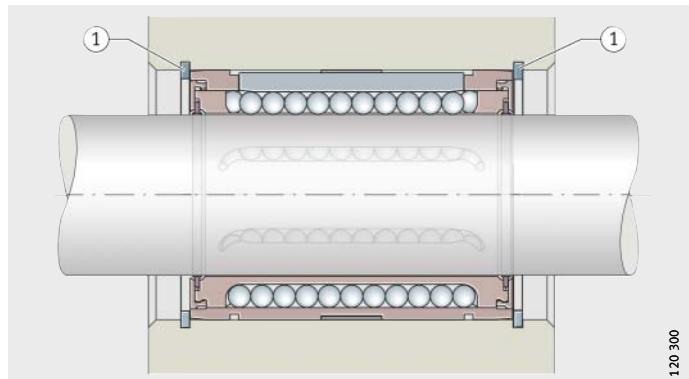


Figure 2
Retaining rings in the housing bore

Design of bearing arrangements

Linear ball bearings KNO..-B, KBO and plain bearings PABO

Linear ball bearings KNO..-B, KBO and plain bearings PABO must be axially located.

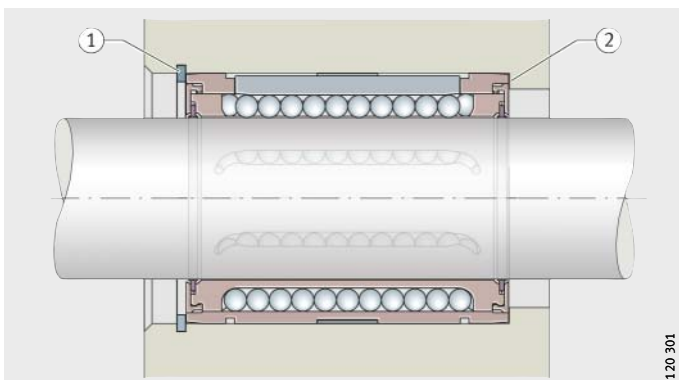
These bearings are located by external means. A dog point screw should preferably be used for location, *Figure 4*. Grub screws are also suitable.



The locating screw must not be allowed to deform the bearing. The screw must be secured against loosening.

- ① Retaining ring
- ② Housing rib

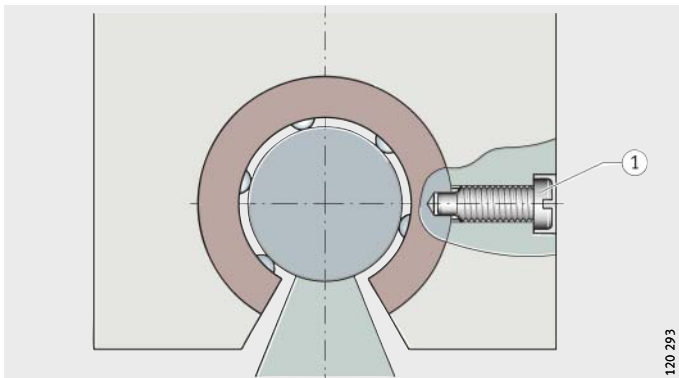
Figure 3
Retaining ring and housing rib



120 301

- ① Dog point retaining screw

Figure 4
Location of the bearing using a screw



120 293



Linear ball bearing and housing units

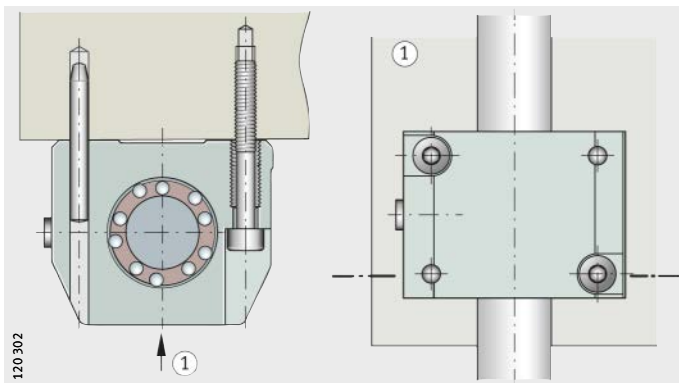
Linear ball bearing and housing units and linear plain bearing units are screw mounted into or through the fixing holes, *Figure 5* and *Figure 6*.

Location of the units by means of dowels is only necessary in rare cases, but can be achieved easily by drilling out the centring holes.

① Bottom view

Figure 5

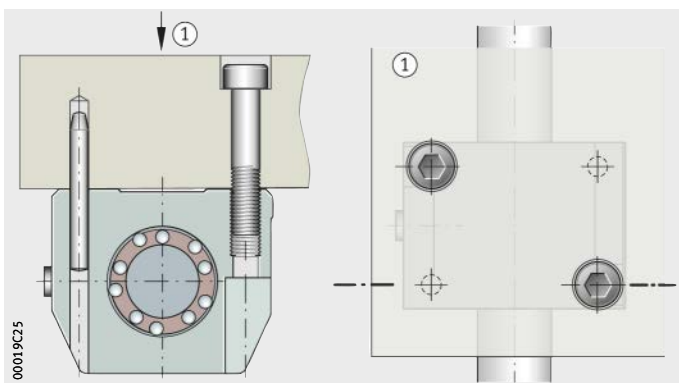
Location of a unit from below



① Top view

Figure 6

Location of a unit from above



Design of bearing arrangements

Sealing

Clean raceways are necessary in order to prevent premature failure of the shaft and bearing. The bearing position should therefore always be sealed.

Gap seals or contact seals

The seals for the bearing series are shown in the table.

Gap seals protect the bearings against coarse contaminants.

Contact seals give protection against fine contaminants and also retain the grease in the bearing.

Linear ball bearings and linear plain bearings with contact seals have the PP, example KH..-PP.



If the bearing and shaft are in a highly aggressive environment, it is recommended that the guidance system should be provided with additional protection by means of bellows or telescopic covers.

Seals for bearings and units

Series ¹⁾	Seal		
	Open design	Gap seals	Contact seals
KH	●	–	●
KN..-B, KNO..-B	–	●	●
KS, KSO	–	●	●
KB, KBO	–	●	●
PAB, PABO	–	–	●

● Available design.

¹⁾ All linear bearing units have contact seals.



Operating clearance

Tolerance and operating clearance

The operating clearance of linear bearings is defined by the selection of shaft and housing tolerance, see tables, page 38.

The operating clearance of linear bearing units is defined either by the shaft or, in the case of slotted housings, is set by means of the adjustment screw.



In the case of non-rigid housings, tests must be carried out in order to achieve the required operating clearance by means of the housing and shaft tolerances.

For adjustment of the operating clearance see page 43.

Tolerance and operating clearance

Linear bearings, linear bearing and housing units	Designation	Tolerance		Operating clearance
		Shaft	Bore	
Compact range	KH	See table, page 38		
	KGHK, KTHK	h6	–	Standard
Light range	KN...-B, KNO...-B	h6	H7	Clearance-free
Heavy duty range	KS, KSO	h6	H7	Clearance-free
	KGSNG, KTSG, KGSNO, KTSO, KGSC, KTFS	h6	–	Slight preload
	KGSNS, KTSS, KGSNOS, KTSOS, KGSCS	–	–	Adjustable by means of screw
Machined range	KB	See table, page 38		
	KBS, KBO			
	KGB, KGBA, KTB, KGBO, KTBO	h6	–	See table, page 38
	KGBS, KGBAS, KGBAO	–	–	Adjustable by means of screw
Plain bearing range	PAB, PABO	h7	H7	Standard
	PAGBA, PAGBAO	h7	–	Standard

Operating clearance

Mounting tolerances and operating clearance

The theoretically possible operating clearance for the individual series is shown in the following tables and *Figure 1*.

Operating clearance for KH, KN...-B, KNO...-B

Mounting tolerance		Operating clearance All sizes	
Shaft	Bore		
h6	H7, K7	Normal operating clearance	Steel/ aluminium
j5	H6, K6	Operating clearance smaller than normal	Steel/ aluminium

Operating clearance for KS, KSO

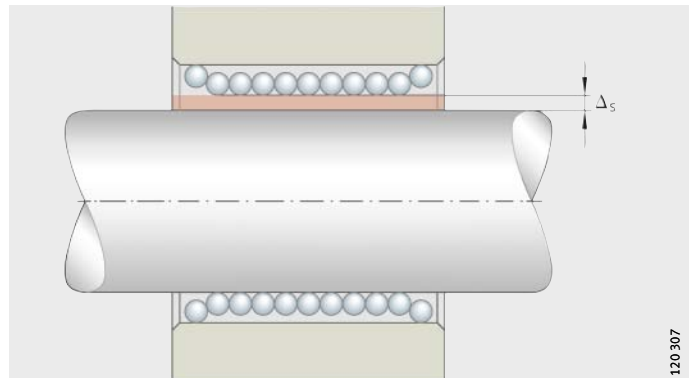
Mounting tolerance		Size and operating clearance						
Shaft	Bore	12 μm	16 μm	20 μm	25 μm	30 μm	40 μm	50 μm
h6	H6	+36 -8	+34 -10	+37 -12	+34 -15	+29 -20	+33 -22	+30 -25
h6	H7	+44 -8	+42 -10	+46 -12	+43 -15	+38 -20	+44 -22	+41 -25
h6	JS6	+29 -14,5	+27,5 -16,5	+29 -20	+26 -23	+21 -28	+23,5 -31,5	+20,5 -34,5

Operating clearance for KB

Mounting tolerance		Size and operating clearance						
Shaft	Bore	12 μm	16 μm	20 μm	25 μm	30 μm	40 μm	50 μm
h6	H6 (H7)	+19 0	+20 -1	+22 -1	+24 -1	+24 -1	+29 -2	+29 -2

Operating clearance for KBS, KBO

Mounting tolerance		Size and operating clearance						
Shaft	Bore	12 μm	16 μm	20 μm	25 μm	30 μm	40 μm	50 μm
h6	H6	+50 0	+51 -1	+60 -1	+62 -1	+62 -1	+74 -2	+74 -2
h6	H7	+58 0	+59 -1	+69 -1	+71 -1	+71 -1	+85 -2	+85 -2
h6	JS6	+43,5 -6,5	+44,5 -7,5	+52 -9	+54 -9	+54 -9	+64,5 -11,5	+64,5 -11,5



Δ_s = operating clearance

Figure 1
Operating clearance



Mounting

The bearings should only be removed from their packaging immediately before mounting. Bearings with dry preservative should be protected against corrosion immediately after removal from the packaging.



The mounting area and the adjacent construction must be clean. Contamination impairs the accuracy and operating life of the guidance systems.

The bearings must not be tilted.

In the case of sealed bearings with a segment cutout, it must be ensured at all costs that the ends of the seal lips are not turned inside out (pay attention to the packing slip).

Mounting of bearings Linear ball bearings KH

Linear ball bearings KH are pressed into the housing bore using a pressing mandrel, *Figure 1*. The mandrel dimensions must be in accordance with *Figure 1*.

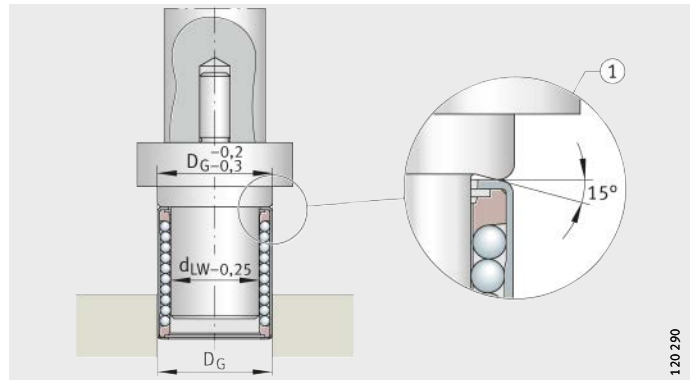
The marked end face of the linear ball bearing should be in contact with the flange of the mandrel.

Linear ball bearings can be mounted more easily if the outside surface is greased.

d_{LW} = shaft diameter
 D_G = housing bore

① Detail

Figure 1
Pressing in
of linear ball bearings KH



Mounting

Linear ball bearings KN..-B, KNO..-B, KB, KBS, KBO, KS, KSO and linear plain bearings PAB, PABO



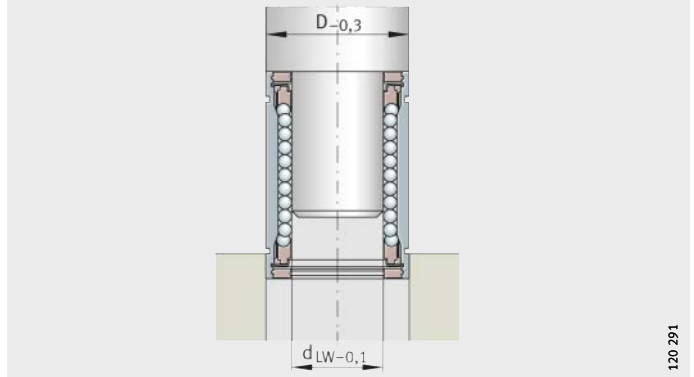
Smaller bearings of these series can be slid into the housing bore by hand. For larger bearings, it is advisable to use a mounting mandrel, *Figure 2*.

The bearings are then located by means of retaining rings or a screw, *Figure 3*.

In the case of all bearings located by means of a screw, it must be ensured that the screw does not deform the bearing and the screw is secured against loosening.

d_{LW} = shaft diameter

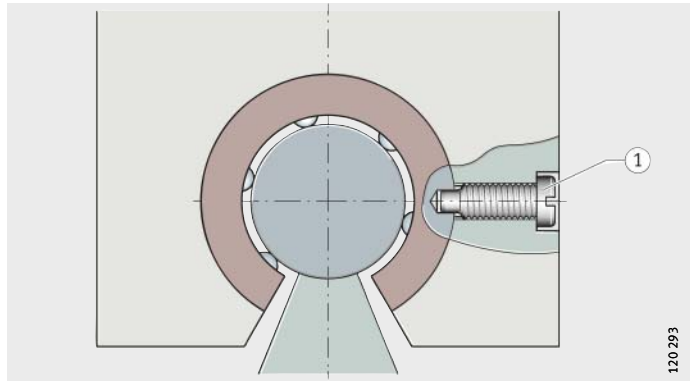
Figure 2
Mounting of linear ball bearings
using fitting mandrel



120 291

① Dog point retaining screw

Figure 3
Location of the bearing
using a screw



120 293



Alignment of bearings and shafts

Bearings arranged in series

Bearings arranged in series should be aligned with a continuous shaft, positioned against a stop and then screw mounted firmly in place.

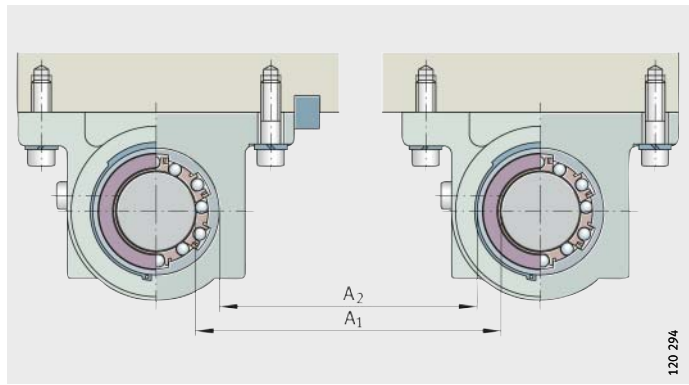
Bearings arranged in parallel

Bearings arranged in parallel are aligned by measuring the spacing between the shafts (A_1) or between the bearing outside diameters (A_2), *Figure 4*. This spacing can also be defined by means of spacers.

The first shaft is set (datum shaft) and screw mounted. The second shaft is aligned by moving the table to achieve the required spacing.

A_1 = spacing between
the shafts
 A_2 = spacing between
the bearing outside diameters

Figure 4
Alignment
of bearings arranged in parallel



Mounting

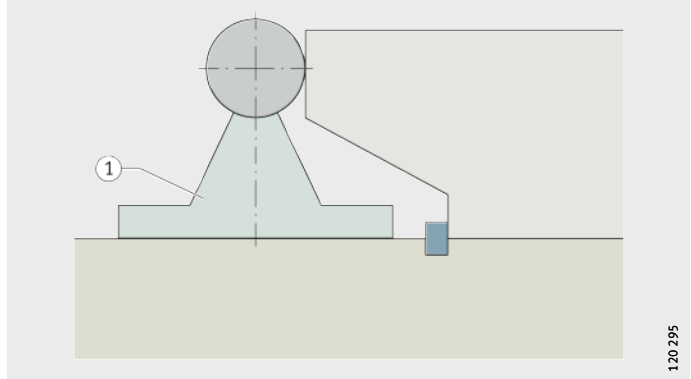
Very long guidance systems with supported shaft

In very long guidance systems with supported shaft, one shaft and support rail unit is first aligned by means of the shaft and screw mounted firmly in place in stages (datum shaft), *Figure 5*.

The procedure described in section Bearings arranged in parallel is then carried out.

① Shaft and support rail unit

Figure 5
Alignment of a shaft and support rail unit by means of the shaft



120 295

Guidance systems with clearance-free or preloaded bearings

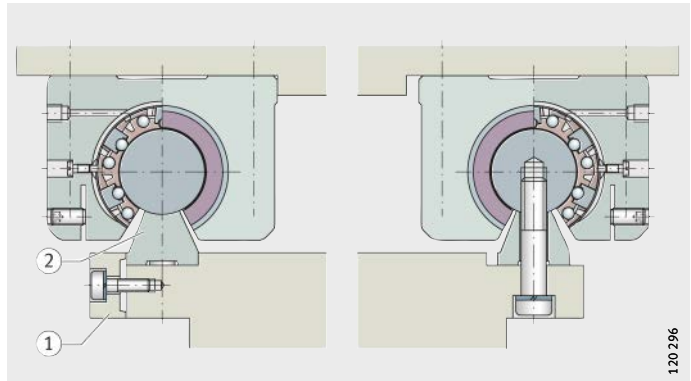
Only one row of bearings arranged in series should be set clearance-free or preloaded. The bearings parallel thereto should have a substantial operating clearance.

Parallel shaft and support rail units

Clamp the datum support rail against a stop, *Figure 6*.

① Stop
② Datum support rail

Figure 6
Clamping of the support rail when using two shaft and support rail units TSUW



120 296



Setting the operating clearance

Setting bearings clearance-free

In the case of linear ball bearings KBS and slotted housings, the operating clearance can be adjusted. The screw must be adjusted until resistance to further rotation can be felt between the shaft and bearing.



The adjusted bearing should not be rotated any further on the shaft.

Setting the preload

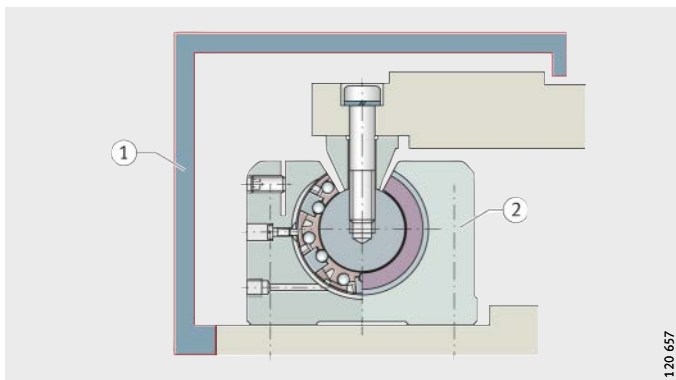
Preloaded bearings are set clearance-free on a master shaft that is smaller than the actual shaft in the application by the amount of the preload dimension.

Suspended arrangement of guidance system



If the guidance system is in a suspended arrangement, a drop guard ① is recommended, *Figure 7*.

- ① Drop guard
- ② Mounting position 180°



120 657

Figure 7
Suspended shaft guidance system
with drop guard



Linear bearings and linear bearing and housing units

Compact range





Light range

Heavy duty range

Machined range

Plain bearing range

Linear bearings and linear bearing and housing units

		Page	
Matrix	Matrix for preselection of linear bearings and linear bearing and housing units.....	46	
Product overview	Linear bearings and linear bearing and housing units.....	48	
	Compact range.....	48	
	Light range.....	48	
	Heavy duty range	49	
	Machined range	50	
	Plain bearing range	51	
Features	Linear bearings.....	52	
	Linear bearing and housing units	53	
	Sealing.....	54	
	Lubrication	55	
	Operating temperature	55	
	Operating limits.....	55	
	Suffixes	55	
	Compact range	56	
	Light range	58	
	Heavy duty range.....	60	
	Machined range	62	
	Plain bearing range.....	64	
Dimension tables	Compact range, linear ball bearings	67	
	Compact range, linear ball bearing and housing units	68	
	Light range, linear ball bearings	74	
	Heavy duty range, linear ball bearings.....	76	
	Heavy duty range, linear ball bearing and housing units	78	
	Machined range, linear ball bearings	90	
	Machined range, linear ball bearing and housing units.....	92	
	Plain bearing range, linear plain bearings	100	
	Plain bearing range, linear plain bearing and housing units	102	

Matrix for preselection of linear bearings and linear bearing and housing units

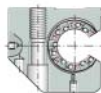
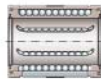
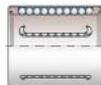
Linear bearings and linear bearing and housing units	For shaft diameter d_{LW} in mm					
	06	08	10	12	14	16
Compact range						
KH, KH...PP	●	●	●	●	●	●
KGHK...PP-AS	●	●	●	●	●	●
KTHK...PP-AS	–	–	–	●	–	●
KGHA...PP	–	–	–	–	–	●
Light range						
KN...B	–	–	–	●	–	●
KN...B-PP						
KNO...B						
KNO...B-PP						
Heavy duty range						
KS, KS...PP	–	–	–	●	–	●
KSO, KSO...PP	–	–	–	●	–	●
KGSNG...PP-AS	–	–	–	●	–	●
KGSNS...PP-AS	–	–	–	●	–	●
KTSG...PP-AS	–	–	–	●	–	●
KTSS...PP-AS	–	–	–	●	–	●
KGSNO...PP-AS	–	–	–	●	–	●
KGSNOS...PP-AS	–	–	–	●	–	●
KTSO...PP-AS	–	–	–	●	–	●
KTSOS...PP-AS	–	–	–	●	–	●
KGSC...PP-AS	–	–	–	●	–	●
KGSCS...PP-AS	–	–	–	●	–	●
KTFS...PP-AS	–	–	–	●	–	●
Machined range						
KB, KBS, KBO	–	–	–	●	–	●
KB...PP, KBS...PP						
KBO...PP						
KB...PP-AS						
KBS...PP-AS						
KBO...PP-AS						
KGB...PP-AS						
KGBS...PP-AS						
KGBO...PP-AS						
KGBA...PP-AS						
KGBAS...PP-AS						
KGBAO...PP-AS						
KFB...B-PP-AS						
KTB...PP-AS						
KTBO...PP-AS						
Plain bearing range						
PAB...PP-AS	–	–	–	●	–	●
PABO...PP-AS						
PAGBA...PP-AS						
PAGBAO...PP-AS						

Definition of symbols
 +++ Very good
 ++ Good
 + Satisfactory
 ● Available for shaft diameter

Linear bearings KH, KN...B, KNO...B, KS, KSO with the suffix PP are sealed on both sides.

Linear bearings with the suffix PP-AS are sealed on both sides and can be relubricated.

					Design		Characteristics					
20	25	30	40	50	Closed	Segment cutout	Feature	Load carrying capacity	Precision	Self-alignment	Adjustable	Description, page
●	●	●	●	●	KH	-	Low section height	+	+	-	-	53, 56
●	●	●	●	●								
●	●	●	●	●								
●	●	●	●	-								
●	●	●	●	●	KN...B	KNO...B	Robust design	+	+	up to ±30	all	53, 58
●	●	●	●	●	KS	KSO	High load capacity	++	++	up to ±40	all	53, 60
●	●	●	●	●								
●	●	●	●	●								
●	●	●	●	●								
●	●	●	-	-								
●	●	●	-	-								
●	●	●	●	●								
●	●	●	●	●								
●	●	●	-	-								
●	●	●	-	-								
●	●	●	-	-								
●	●	●	●	●								
●	●	●	-	-								
●	●	●	●	●	KB	KBO	High precision	+	+++	-	KBS	53, 62
●	●	●	●	●	PAB	PABO	Plain bearings	+++	++	-	-	53, 64



Product overview

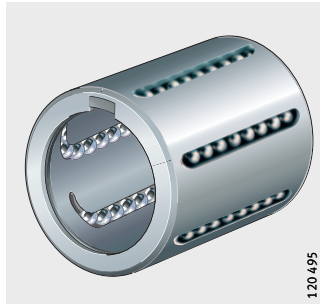
Linear bearings and linear bearing and housing units

Compact range

Linear ball bearings
With and without seals

Features, see page 56

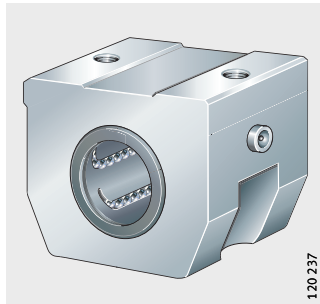
KH, KH...-PP



120 495

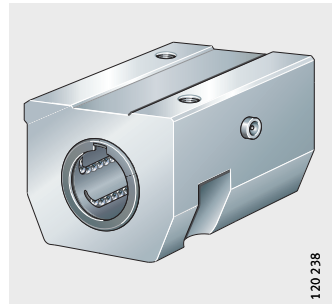
Closed units
Bearings in single or tandem arrangement

KGHK...-B-PP-AS



120 237

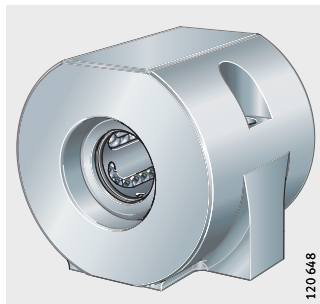
KTHK...-B-PP-AS



120 238

Closed unit

KGHA...-PP



120 648

Light range

Linear ball bearings
Closed or with segment cutout
With and without seals

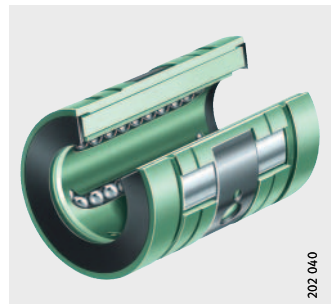
Features, see page 58

KN...-B, KN...-B-PP



202 039

KNO...-B, KNO...-B-PP



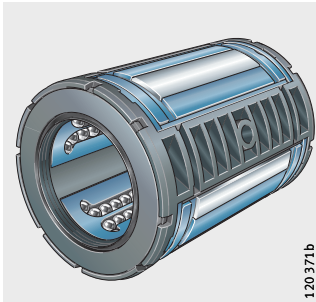
202 040

Heavy duty range

Linear ball bearings
Closed or with segment cutout
With and without seals

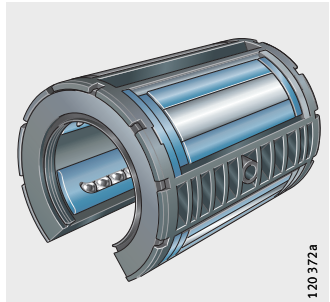
Features, see page 60

KS, KS..-PP



120 371b

KSO, KSO..-PP

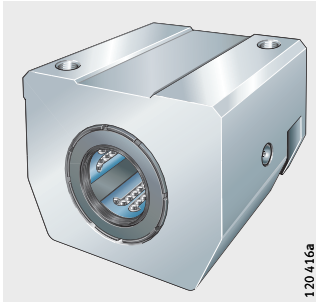


120 372a



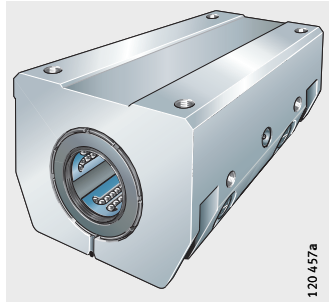
Closed units
Housing closed or slotted
Bearings in single or tandem arrangement

KGSNG...-PP-AS,
KGSNS...-PP-AS



120 416a

KTSG...-PP-AS,
KTSS...-PP-AS

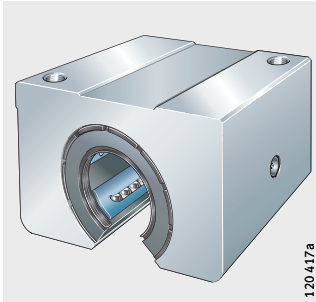


120 457a



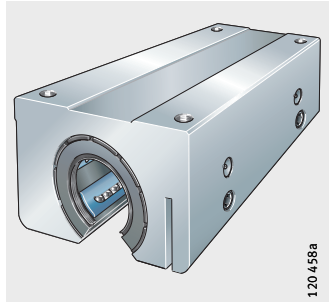
Units
with segment cutout
Housing not slotted or slotted
Bearings in single or tandem arrangement

KGSNO...-PP-AS,
KGSNOS...-PP-AS



120 417a

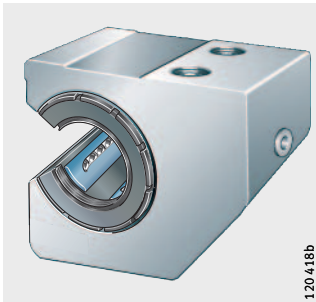
KTSO...-PP-AS,
KTSOS...-PP-AS



120 458a

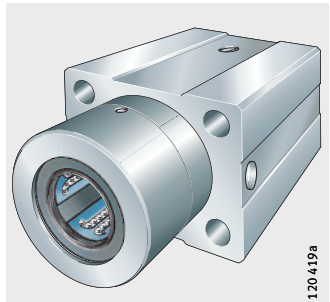
Bearings in single or tandem arrangement
Housing not slotted or slotted
Unit with centring collar

KGSC...-PP-AS,
KGSCS...-PP-AS



120 418b

KTFS



120 419a

Product overview

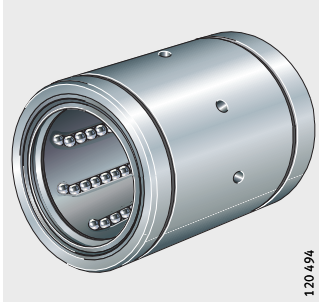
Linear bearings and linear bearing and housing units

Machined range

Linear ball bearings
 Closed or with slot
 With segment cutout
 With and without seals

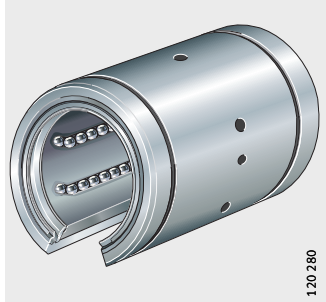
Features, see page 62

KB, KB...-PP, KB...-PP-AS,
 KBS, KBS...-PP, KBS...-PP-AS



120 494

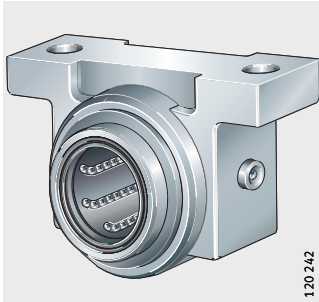
KBO, KBO...-PP, KBO...-PP-AS



120 280

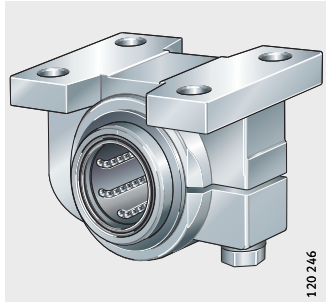
Closed units
 Housing closed or slotted

KGB...-PP-AS,
 KGBS...-PP-AS



120 242

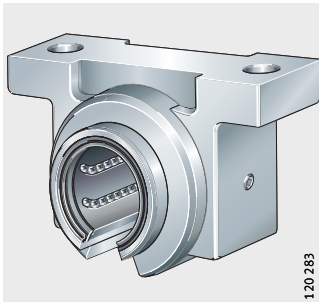
KGBA...-PP-AS,
 KGBAS...-PP-AS



120 246

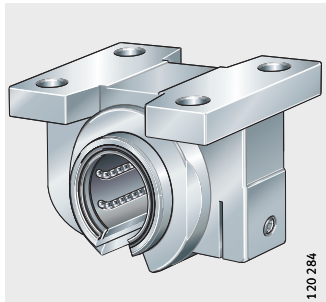
Units with segment cutout
 Housing not slotted or slotted

KGBO...-PP-AS



120 283

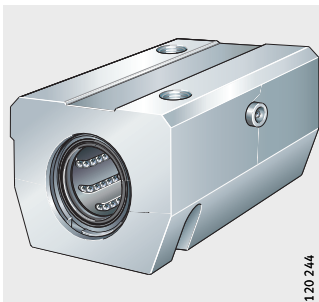
KGBAO...-PP-AS



120 284

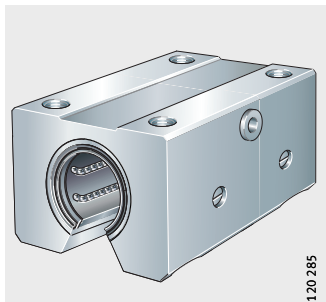
Closed units or units with segment output
 Bearings in tandem arrangement

KTB...-PP-AS



120 244

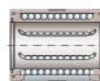
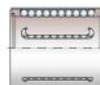
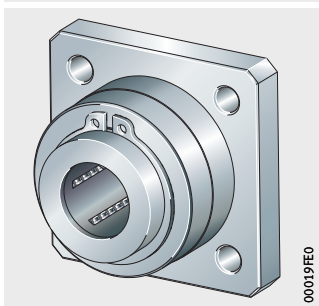
KTBO...-PP-AS



120 285

Closed unit
Housing with flange

KFB..-B-PP-AS

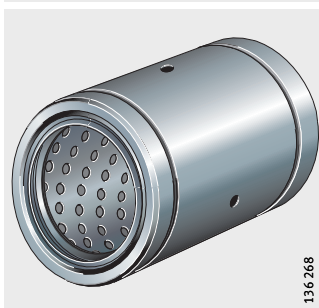


Plain bearing range

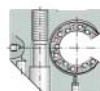
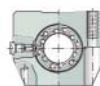
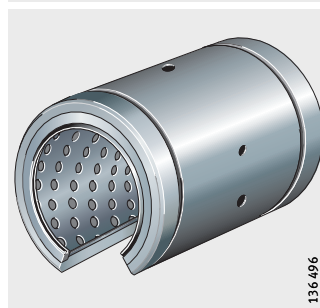
Linear plain bearings
Closed or with segment cutout
Sealed

Features, see page 64

PAB..-PP-AS

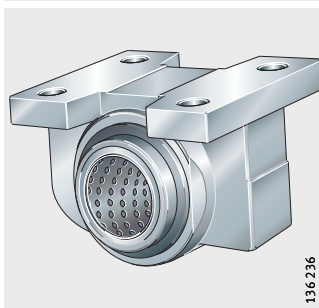


PABO..-PP-AS

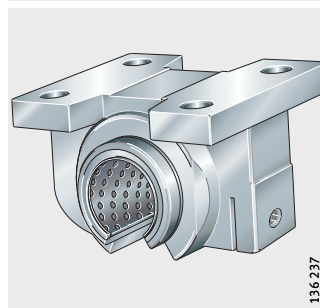


Linear plain bearing and housing units
Closed or with segment cutout

PAGBA..-PP-AS



PAGBAO..-PP-AS



Linear bearings and linear bearing and housing units

Features

Linear bearings and linear bearing and housing units are available in the compact, light, heavy duty, machined and plain bearing range. The bearings can support high loads while having a relatively low mass and allow the construction of linear guidance systems with unlimited travel.

Each series has highly specific characteristics that precisely define it as suitable for particular applications. These may include, for example, requirements for compensation of misalignments, low-friction running, high accelerations and travel velocities or long operating life.

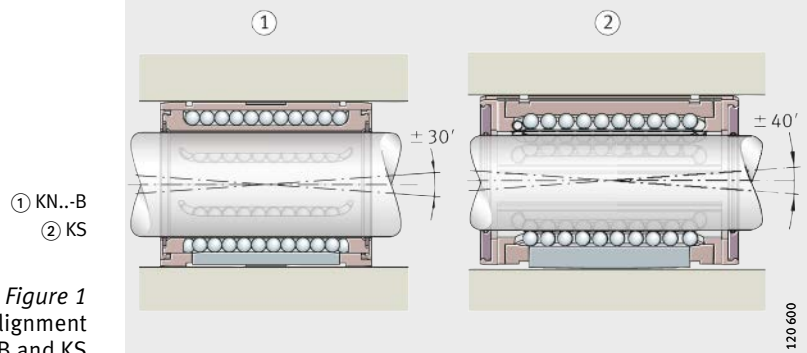
The range, which has been constructed and expanded in accordance with a modular concept, provides the best technical and economic solution, in relation to each application, for bearing arrangements with shaft guidance systems.

Linear bearings

Linear ball bearings and linear plain bearings are available in open or closed designs. The open design has a segment cut out and is intended for supported shafts. Several series allow, in conjunction with the corresponding housings, adjustment of the radial clearance in order to achieve clearance-free or preloaded guidance systems.

Compensation of misalignment

Misalignment can be caused by tolerance defects, mounting errors or inaccuracies in the adjacent construction. Linear ball bearings of the series KN...-B and KNO...-B can compensate static misalignment of up to $\pm 30'$, linear ball bearings of the series KS and KSO can compensate static misalignment of up to $\pm 40'$, *Figure 1*.



Due to the self-alignment function, the balls run without difficulty into the load zone. At the same time, the load distribution over the whole ball row is more uniform. This leads to smoother running, allows higher accelerations and prevents overloading of the individual balls.



Overall, this means that the bearings can achieve higher loads and a longer operating life; if necessary, the adjacent construction can be designed to be smaller and more economical.



In order to fully utilise the basic load ratings given in the dimension table, the shaft raceway must be hardened (670 HV + 165 HV) and ground. The indications in section Design of bearing arrangements must be observed, page 33.



Linear bearing and housing units

Linear ball bearings and plain bearings are also available in conjunction with INA housings as complete bearing units. The linear bearing is located in the housing by means of a radial fixing screw to prevent axial displacement.

The housings are made from a high rigidity, high strength aluminium alloy that allows the full load carrying capacity of the bearings fitted to be utilised. In the machined series, pressure diecast housings are also available.



Due to the comparatively low total mass, the units are particularly suitable for reduced mass designs with high loads and where higher accelerations and travel velocities are required.

Simple location

Threaded or counterbored holes in the housing allow straightforward screw mounting on the adjacent construction, if necessary from below.

For rapid alignment, the housings have a locating edge. This also prevents distortion of the linear bearings when the housings are being mounted.

Centring holes allow rapid additional location of the housings by dowels on the adjacent construction.



Linear bearings and linear bearing and housing units

Housing designs	The housings are available in closed design, with a segment cutout and in open, slotted and tandem versions (with and without a centring collar).
Closed design	In this variant, the bearings and housings are closed. As a result, high precision standard guidance systems with a fixed enveloping circle can be easily achieved.
With segment cutout	Open designs with a segment cutout are used where, in the case of long guidance systems, the shaft must be supported and the bearing arrangement must be highly rigid.
Slotted design	Closed designs and designs with a segment cutout are also available in several series with a slot. Slotted variants are suitable for clearance-free or preloaded guidance systems. The operating clearance is set by means of an adjusting screw.
Tandem design	The tandem version contains two linear bearings. As a result, the units have particularly high load carrying capacity. Tandem ball bearing and housing units are available in open and closed designs. Both variants are also available in the named design with a slot.
With centring collar	For special applications, there is also a tandem version with a centring collar for locating bores to H7.
Highly cost-effective	As a result of volume production in large quantities, the complete units are normally considerably more economical than customers' own designs.
Sealing	The bearings are available in an open version and with contact seals on both sides (suffix PP). The linear bearings of type KH, KN..-B and KB have seals with two seal lips on their end faces; the outer lip prevents the ingress of contamination, the inner lip retains the lubricant in the bearing. The linear bearings of type KS have contact seals with one seal lip.

Lubrication

Due to the initial greasing with a high quality grease and the integral lubricant reservoir, the linear bearings are maintenance-free for many applications; if necessary, however, they can be relubricated. Linear ball bearings can be lubricated, depending on the design, via the openings in the outer ring or radial holes arranged in the centre of the bearing.

In the units, lubrication is carried out via a separate lubrication nipple in the housing; location of the bearing in the housing and the relubrication devices are thus separate from each other.



Operating temperature

The bearings and housings can be used at operating temperatures from -30 °C to +80 °C.



Operating limits

The table shows the operating limits for linear bearings. Once the interrelationships of bearing size and design, load, operating clearance, location of bearings and lubrication have been checked, it may be possible in individual cases to use higher values. In this case, please contact us.



Linear bearing and housing units should be allocated in accordance with the linear bearing fitted.



Dynamic values for linear bearings

Acceleration, velocity	Linear bearing series				
	KH	KN..-B	KB	KS	PAB
Acceleration in m/s ²	50	50	50	100	50
Velocity in m/s	2	up to 5	up to 5	up to 5	up to 3

In the case of linear ball bearings with seals, suffix PP, velocities up to 2 m/s are permissible.



Suffixes

Suffixes for available designs: see table.

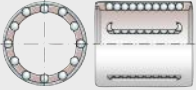

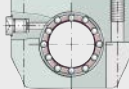
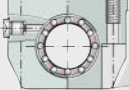

Available designs

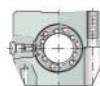
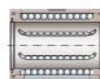
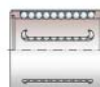
Suffix	Description	Design
PP	Lip seals on both sides	Standard
PPL	Sealing strips on bearings with segment cutout	Available by agreement
AS	Bearing and unit with relubrication facility	Standard

Linear bearings and linear bearing and housing units

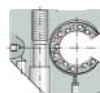
Compact range	<p>Linear ball bearings KH and linear ball bearing and housing units of the compact range have a small radial design envelope and are particularly economical. Their low section height automatically makes them attractive for applications in which only a small amount of radial space is available.</p> <p>Due to the closed design, they are suitable for use on shafts.</p>
Linear ball bearings	<p>The bearings have an outer ring with openings. This contains a ball and cage assembly with a plastic cage. The outer ring is formed and hardened. The balls undergo return travel along the openings in the outer ring.</p>
Seals	<p>The bearings are available in an open version and with lip seals on both sides (suffix PP). The end face seals have two seal lips; the outer lip prevents the ingress of contamination, the inner lip retains the lubricant in the bearing.</p>
Linear ball bearing and housing units	<p>Linear ball bearing and housing units of the compact range are available with one integral bearing and, in the tandem version with particularly high load carrying capacity, with two bearings. The housings are made from high strength aluminium.</p>
Anti-corrosion protection	<p>The housings are two-piece components made from sheet steel with a Corrotect® coating. The bearings and housing parts are packed separately. The bearing is firmly seated once it is mounted in the housing.</p>
Further information	<p>Further information is given on the following pages:</p> <ul style="list-style-type: none">■ dimension tables, see page 67■ shafts, see page 104■ shaft and support rail units, see page 128■ accessories, see page 144.

**Linear ball bearings and
linear ball bearing and
housing units, compact range**

Series ¹⁾	Feature
KH 	<ul style="list-style-type: none"> ■ Linear ball bearings ■ Not sealed
KH...PP 	<ul style="list-style-type: none"> ■ Linear ball bearings ■ Lip seals on both sides
KGHK...PP-AS 	<ul style="list-style-type: none"> ■ Closed design ■ Relubrication facility
KTHK...PP-AS 	<ul style="list-style-type: none"> ■ Closed design ■ Tandem design ■ Relubrication facility
KGHA...PP 	<ul style="list-style-type: none"> ■ Unit ■ Closed design



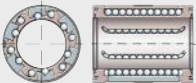
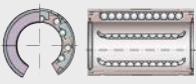
¹⁾ Bearings with the suffix PP have lip seals on both sides.



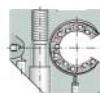
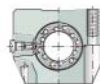
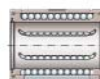
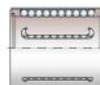
Linear bearings and linear bearing and housing units

- Light range** The light range is available as linear ball bearings KN..-B of a closed design and as linear ball bearings KNO..-B with a segment cutout. In order to compensate misalignments arising from manufacturing tolerances, mounting errors and shaft deflection, the linear bearings of series KN..-B are self-aligning up to $\pm 30'$. Their robust construction allows operation even under aggressive operating conditions. The series KN..-B is of a closed construction and is designed for use on shafts. KNO..-B has a segment cutout and is used with shaft and support rail units.
- Linear ball bearings** Linear ball bearings KN..-B and KNO..-B comprise a plastic cage with inserted raceway plates. The plates are supported in the housing bore by means of a retaining ring. Due to the retaining ring, the plates can “rock” and thus compensate for static misalignments.
- Seals** The bearings are available in an open version and with lip seals on both sides (suffix PP). The end face seals have two seal lips; the outer lip prevents the ingress of contamination, the inner lip retains the lubricant in the bearing.
- Further information** Further information is given on the following pages:
- dimension tables, see page 74
 - shafts, see page 104
 - shaft and support rail units, see page 128
 - accessories, see page 144.

Linear ball bearings, light range

Series ¹⁾	Feature
KN..-B KN..-B-PP 	<ul style="list-style-type: none"> ■ Linear ball bearings ■ Closed design ■ Self-aligning ■ With or without lip seals
KNO..-B KNO..-B-PP 	<ul style="list-style-type: none"> ■ Linear ball bearings ■ With segment cutout ■ Self-aligning ■ With or without lip seals

¹⁾ Bearings with the suffix PP have lip seals on both sides.



Linear bearings and linear bearing and housing units

Heavy duty range	Linear ball bearings of the heavy duty range KS and KSO and the corresponding ball bearing and housing units have particularly high load carrying capacity and have an angular adjustment facility for compensation of misalignments. They have very good running characteristics.
Linear ball bearings	<p>Linear ball bearings KS and KSO comprise a plastic cage with loosely retained segments. The double row segments with crowned raceway plates can realign themselves in all directions and thus compensate misalignments. Since the complete segment undergoes realignment, there is no disruption to the recirculation of the balls. This results in uniformly low displacement resistance.</p> <p>The series KS is of a closed construction and is designed for use on shafts. KSO has a segment cutout and is used in conjunction with shaft and support rail units.</p>
Seals	The bearings are available with contact seals or gap seals. The contact seals on the end faces have two seal lips; the outer lip prevents the ingress of contamination, the inner lip retains the lubricant in the bearing.
Linear ball bearing and housing units	<p>Linear ball bearing and housing units of the heavy duty range are available with one integral bearing and, in the tandem version with particularly high load carrying capacity, with two bearings. The housings are made from high strength aluminium.</p> <p>The housings are available in a closed design, with a segment cutout for supported shafts and with or without a slot. In designs with a slot, the radial clearance can be adjusted by means of an adjusting screw. All series have a locating edge and centring holes for dowel holes. The bearings are sealed on both sides, they have an initial greasing and can be relubricated via a lubrication nipple in the housing.</p>
Further information	<p>Further information is given on the following pages:</p> <ul style="list-style-type: none"> ■ dimension tables, see page 76 ■ shafts, see page 104 ■ shaft and support rail units, see page 128 ■ accessories, see page 144.

Linear ball bearings and linear ball bearing and housing units, heavy duty range

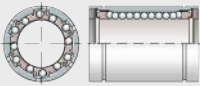
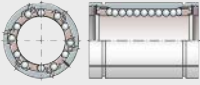
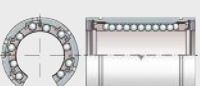



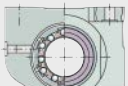
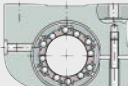
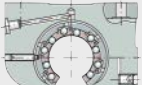
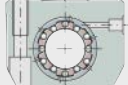

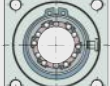
Series ¹⁾		Feature
KS KS...PP		<ul style="list-style-type: none"> Linear ball bearings Self-aligning With or without lip seals
KSO KSO...PP		<ul style="list-style-type: none"> Linear ball bearings With segment cutout Self-aligning With or without lip seals
KGNG...PP-AS		<ul style="list-style-type: none"> Closed design Relubrication facility
KGSNS...PP-AS		<ul style="list-style-type: none"> Closed design Slotted housing Relubrication facility
KTSG...PP-AS		<ul style="list-style-type: none"> Closed design Tandem arrangement Relubrication facility
KTSS...PP-AS		<ul style="list-style-type: none"> Closed design Tandem arrangement Slotted housing Relubrication facility
KGNO...PP-AS		<ul style="list-style-type: none"> With segment cutout Relubrication facility
KGNOS...PP-AS		<ul style="list-style-type: none"> With segment cutout Slotted housing Relubrication facility
KTSO...PP-AS		<ul style="list-style-type: none"> With segment cutout Tandem arrangement Relubrication facility
KTSOS...PP-AS		<ul style="list-style-type: none"> With segment cutout Tandem arrangement Slotted housing Relubrication facility
KGSC...PP-AS		<ul style="list-style-type: none"> Open at side Relubrication facility
KGSCS...PP-AS		<ul style="list-style-type: none"> Open at side Slotted housing Relubrication facility
KTFS...PP-AS		<ul style="list-style-type: none"> With centring collar Tandem arrangement Relubrication facility

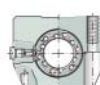
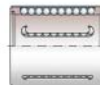
¹⁾ Bearings with the suffix PP have lip seals on both sides.

Linear bearings and linear bearing and housing units

Machined range	Linear ball bearings of the machined range KB, KBS and KBO and the corresponding linear ball bearing and housing units are high precision and particularly rigid. They have excellent running characteristics.
Linear ball bearings	<p>Linear ball bearings KB, KBS and KBO comprise a hardened and ground outer ring in which a ball and cage assembly with a plastic cage is integrated.</p> <p>The balls are guided with high precision throughout the return area by a special spring washer. This ensures that the displacement resistance remains uniformly low even under difficult operating conditions and irrespective of the mounting position.</p> <p>The series KB is of a closed construction and is designed for use on shafts. KBO has a segment cutout and is used in conjunction with shaft and support rail units. KBS has a slot for adjustment of the radial clearance.</p>
Seals	The bearings have contact seals or gap seals.
Linear ball bearing and housing units	<p>Linear ball bearing and housing units of the machined range are available with one integral bearing and, in the tandem version with particularly high load carrying capacity, with two bearings.</p> <p>The housings are made from high strength aluminium or are pressure diecast.</p> <p>The housings are available in a closed design, with a segment cutout for supported shafts and with or without a slot. In designs with a slot, the radial clearance can be adjusted by means of an adjusting screw.</p> <p>All series have a locating edge and centring holes for dowel holes.</p> <p>The bearings are sealed on both sides, they have an initial greasing and can be relubricated via a lubrication nipple in the housing.</p>
Further information	<p>Further information is given on the following pages:</p> <ul style="list-style-type: none"> ■ dimension tables, see page 90 ■ shafts, see page 104 ■ shaft and support rail units, see page 128 ■ accessories, see page 144.

Linear ball bearings and linear ball bearing and housing units, machined range

Series ¹⁾²⁾		Feature
KB KB...PP KB...PP-AS		<ul style="list-style-type: none"> Linear ball bearings With or without lip seals depending on the design Relubrication facility
KBS KBS...PP KBS...PP-AS		<ul style="list-style-type: none"> Linear ball bearings With or without lip seals depending on the design Relubrication facility Slotted design
KBO KBO...PP KBO...PP-AS		<ul style="list-style-type: none"> Linear ball bearings With or without lip seals depending on the design Relubrication facility With segment cutout
KGB...PP-AS		<ul style="list-style-type: none"> Closed design Relubrication facility
KGBS...PP-AS		<ul style="list-style-type: none"> Closed design Slotted housing Relubrication facility
KGBO...PP-AS		<ul style="list-style-type: none"> With segment cutout Relubrication facility
KGBA...PP-AS		<ul style="list-style-type: none"> Closed design Relubrication facility
KGBAS...PP-AS		<ul style="list-style-type: none"> Closed design Slotted housing Relubrication facility
KGBAO...PP-AS		<ul style="list-style-type: none"> With segment cutout Relubrication facility
KTB...PP-AS		<ul style="list-style-type: none"> Closed design Tandem arrangement Relubrication facility
KTBO...PP-AS		<ul style="list-style-type: none"> With segment cutout Tandem arrangement Relubrication facility
KFB...B-PP-AS		<ul style="list-style-type: none"> Closed design Relubrication facility



1) Bearings with the suffix PP have lip seals on both sides.
2) Bearings and units with the suffix AS can be relubricated.

Linear bearings and linear bearing and housing units

Plain bearing range

Linear plain bearings PAB and PABO and the corresponding plain bearing and housing units have very high load carrying capacity, are extremely robust and have particularly low running noise. They have excellent emergency running characteristics.

Linear plain bearings

Linear plain bearings PAB and PABO comprise an outer ring made from high strength aluminium into which plain bearing bushes PAP..-P20 are fixed by adhesive.

The series PAB is of a closed construction and is designed for use on shafts. PABO has a segment cutout and is used in conjunction with shaft and support rail units.



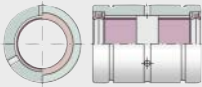
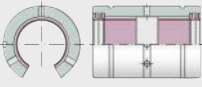

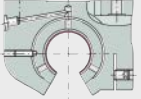
Plain bushes must not be used in conjunction with the special coating Corrotect®. Crevice corrosion may occur that would impair the function of the bearing.

Further information

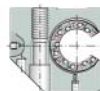
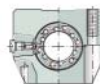
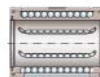
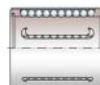
Further information is given on the following pages:

- dimension tables, see page 100
- shafts, see page 104
- shaft and support rail units, see page 128
- accessories, see page 144.

**Linear plain bearings and
linear plain bearing and
housing units,
plain bearing range**

Series ¹⁾		Feature
PAB...-PP-AS		<ul style="list-style-type: none"> ■ Closed design ■ Lip seals on both sides ■ Relubrication facility
PABO...-PP-AS		<ul style="list-style-type: none"> ■ With segment cutout ■ Lip seals on both sides ■ Relubrication facility
PAGBA...-PP-AS		<ul style="list-style-type: none"> ■ Closed design ■ Relubrication facility
PAGBAO...-PP-AS		<ul style="list-style-type: none"> ■ With segment cutout ■ Slotted housing ■ Relubrication facility

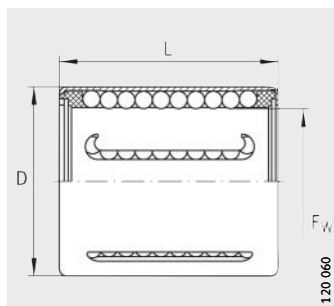
¹⁾ Bearings with the suffix PP have lip seals on both sides.



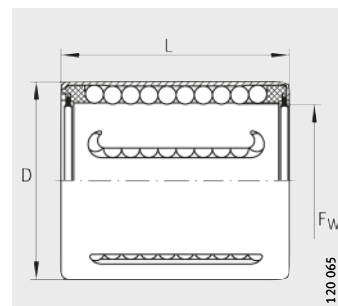
Compact range

Linear ball bearings

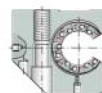
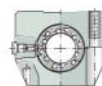
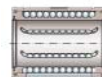
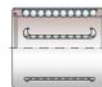
Open or sealed
Relubrication facility



KH



KH...-PP

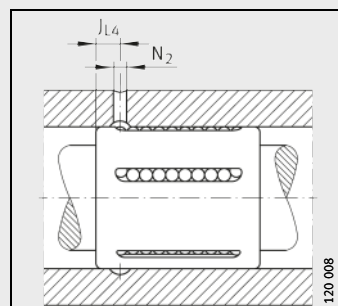


Dimension table · Dimensions in mm

Designation		Mass m g	Dimensions			Mounting dimensions		Basic load ratings ¹⁾			
2)	3)		F _w	D	L	J _{L4}	N ₂	dyn. C _{min} N	stat. C _{0 min} N	dyn. C _{max} N	stat. C _{0 max} N
KH06	KH06-PP	7	6	12	22	4	2	340	240	390	340
KH08	KH08-PP	12	8	15	24	6	2	410	280	475	400
KH10	KH10-PP	14,5	10	17	26	6	2,5	510	370	590	520
KH12	KH12-PP	18,5	12	19	28	6	2,5	670	510	800	740
KH14	KH14-PP	20,5	14	21	28	6	2,5	690	520	830	760
KH16	KH16-PP	27,5	16	24	30	7	2,5	890	620	1060	910
KH20	KH20-PP	32,5	20	28	30	7	2,5	1110	790	1170	1010
KH25	KH25-PP	66	25	35	40	8	2,5	2280	1670	2420	2130
KH30	KH30-PP	95	30	40	50	8	2,5	3300	2700	3300	3100
KH40	KH40-PP	182	40	52	60	9	2,5	5300	4450	5300	4950
KH50	KH50-PP	252	50	62	70	9	2,5	6800	6300	6800	7000

Corrosion-resistant designs have the suffix -RROC.
This must be stated when ordering.

- 1) The basic load ratings are only valid for hardened (670 HV + 165 HV) and ground shaft raceways.
- 2) With preservative.
- 3) With initial greasing, sealed on both sides.

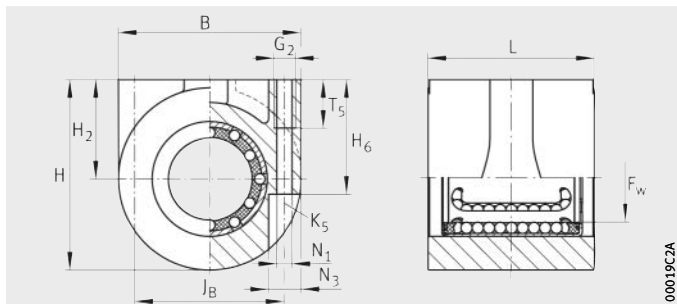


Mounting dimensions

Compact range

Linear ball bearing and housing units

Sealed
Greased



KGHA..-PP

00019C2A

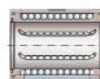
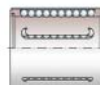
Dimension table - Dimensions in mm

Designation	Mass m ≈g	Dimensions				
		F _w	H ₂ ±0,015	H	B	L +0,5
KGHA16-PP	228	16	20	41	42	37
KGHA20-PP	303	20	25	48,5	47	39
KGHA25-PP	496	25	30	57,5	55	49
KGHA30-PP	860	30	35	67,5	65	59
KGHA40-PP	1 434	40	45	84	78	71

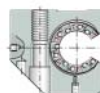
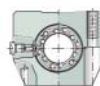
¹⁾ The basic load ratings are only valid for hardened (670 HV + 165 HV) and ground shaft raceways.

²⁾ For fixing screws ISO 4762-8.8.

If there is a possibility of settling, the screws should be secured against rotation.



Mounting dimensions							Basic load ratings ¹⁾	
H ₆	T ₅	J _B ±0,1	G ₂	N ₁	N ₃	K ₅ ²⁾	dyn. C N	stat. C ₀ N
27	15	32	M6	5,1	8,1	M4	890	620
29	15	38	M6	5,1	8,1	M4	1 110	790
35	15	46	M6	5,1	8,1	M4	2 280	1 670
39	20	54	M8	6,7	11,1	M6	3 300	2 700
49	20	66	M8	6,7	11,1	M6	5 300	4 450

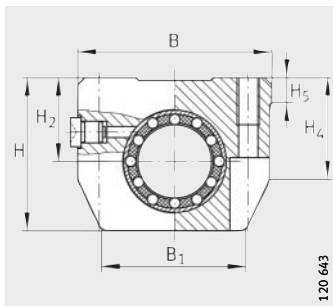


Compact range

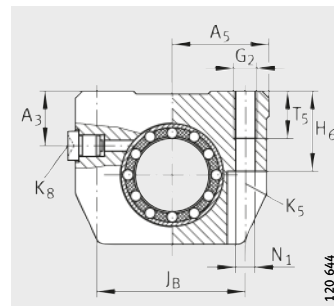
Linear ball bearing and housing units

Sealed

Greased, with relubrication facility



KGHK...-B-PP-AS



KGHK...-B-PP-AS

Dimension table - Dimensions in mm

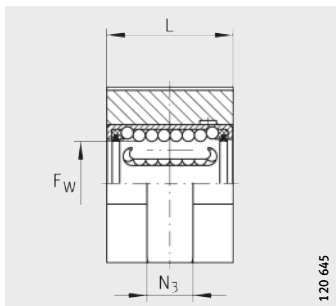
Designation	Mass m ≈g	Dimensions				Mounting dimensions		
		F _w	B	L	H	J _B	B ₁	A ₅
KGHK06-B-PP-AS	40	6	32	22,2	27	±0,15 23	25	16
KGHK08-B-PP-AS	50	8	32	24,2	27	23	25	16
KGHK10-B-PP-AS	70	10	40	26,2	33	29	32	20
KGHK12-B-PP-AS	80	12	40	28,2	33	29	32	20
KGHK14-B-PP-AS	100	14	43	28,2	36,5	34	34	21,5
KGHK16-B-PP-AS	110	16	43	30,2	36,5	34	34	21,5
KGHK20-B-PP-AS	150	20	53	30,2	42,5	40	40	26,5
KGHK25-B-PP-AS	270	25	60	40,2	52,5	48	44	30
KGHK30-B-PP-AS	400	30	67	50,2	60	53	49,6	33,5
KGHK40-B-PP-AS	750	40	87	60,2	73,5	69	63	43,5
KGHK50-B-PP-AS	1 250	50	103	70,2	92	82	74	51,5

1) The basic load ratings are only valid for hardened (670 HV + 165 HV) and ground shaft raceways.

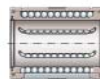
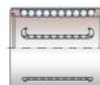
2) For fixing screws ISO 4762-8.8.

If there is a possibility of settling, the screws should be secured against rotation.

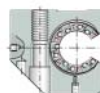
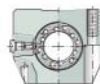
3) Lubrication nipple, see page 31.



KGHK..B-PP-AS



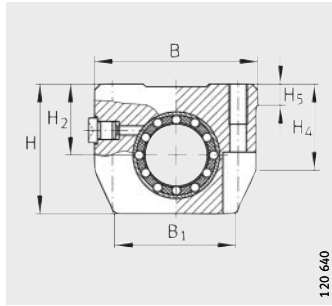
											Basic load ratings ¹⁾	
H ₂ +0,010 -0,014	H ₄	H ₅	T ₅	H ₆	A ₃	G ₂	N ₁	N ₃	K ₅ ²⁾	K ₈ ³⁾	dyn. C N	stat. C ₀ N
13	20,6	5	9	13	9	M4	3,4	7	M3	NIPA1	340	240
14	20,6	5	9	13	9	M4	3,4	7	M3	NIPA1	410	280
16	25,1	5	11	16	11	M5	4,3	10	M4	NIPA1	510	370
17	25,1	5	11	16	11	M5	4,3	10	M4	NIPA1	670	510
18	28,1	6,9	11	18	13	M5	4,3	10	M4	NIPA1	690	520
19	28,1	6,9	11	18	13	M5	4,3	10	M4	NIPA1	890	620
23	29,8	7,4	13	22	15	M6	5,3	11	M5	NIPA2	1 110	790
27	36,6	9,9	18	26	17,5	M8	6,6	15	M6	NIPA2	2 280	1 670
30	42,7	8	18	29	18	M8	6,6	15	M6	NIPA2	3 300	2 700
39	49,7	12,8	22	38	23	M10	8,4	18	M8	NIPA2	5 300	4 450
47	62,3	10,9	26	46	28	M12	10,5	20	M10	NIPA2	6 800	6 300



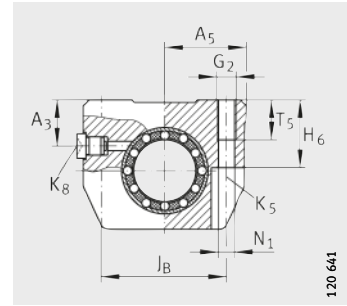
Compact range

Linear ball bearing and housing units

Tandem arrangement
Sealed
Greased,
with relubrication facility



KTHK...-B-PP-AS



KTHK...-B-PP-AS

Dimension table - Dimensions in mm

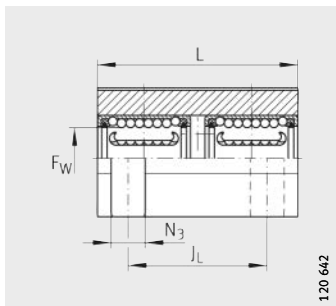
Designation	Mass m ≈g	Dimensions				Mounting dimensions			
		F _w	B	L	H	J _B	B ₁	A ₅	J _L ²⁾
KTHK12-B-PP-AS	170	12	40	60	33	±0,15	32	20	±0,15
KTHK16-B-PP-AS	230	16	43	65	36,5	34	34	21,5	40
KTHK20-B-PP-AS	320	20	53	65	42,5	40	40	26,5	45
KTHK25-B-PP-AS	580	25	60	85	52,5	48	44	30	55
KTHK30-B-PP-AS	850	30	67	105	60	53	49,6	33,5	70
KTHK40-B-PP-AS	1 600	40	87	125	73,5	69	63	43,5	85
KTHK50-B-PP-AS	2 700	50	103	145	92	82	74	51,5	100

1) The basic load ratings are only valid for hardened (670 HV + 165 HV) and ground shaft raceways and where the two linear ball bearings are subjected to equal loading.

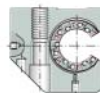
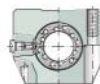
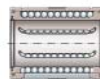
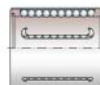
2) Dimension J_L and lubrication hole symmetrical to the bearing length L.

3) For fixing screws ISO 4762-8.8.
If there is a possibility of settling, the screws should be secured against rotation.

4) Lubrication nipple, see page 31.



KTHK..B-PP-AS

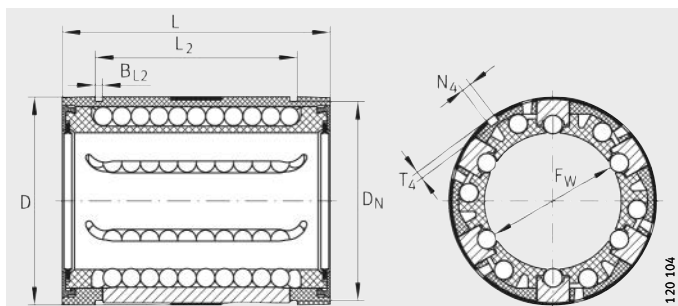


											Basic load ratings ¹⁾	
H ₂ +0,010 -0,014	H ₄	H ₅	T ₅	H ₆	A ₃	G ₂	N ₁	N ₃	K ₅ ³⁾	K ₈ ⁴⁾	dyn. C N	stat. C ₀ N
17	25,1	5	11	16	11	M5	4,3	10	M4	NIPA1	1 090	1 020
19	28,1	6,9	11	18	13	M5	4,3	10	M4	NIPA1	1 440	1 240
23	29,8	7,4	13	22	15	M6	5,3	11	M5	NIPA2	1 800	1 580
27	36,6	9,9	18	26	17,5	M8	6,6	11	M6	NIPA2	3 700	3 350
30	42,7	8	18	29	18	M8	6,6	15	M6	NIPA2	5 400	5 400
39	49,7	12,8	22	38	23	M10	8,4	18	M8	NIPA2	8 600	6 900
47	62,3	10,9	26	46	28	M12	10,5	20	M10	NIPA2	11 000	12 600

Light range

Linear ball bearings

- Self-aligning
- Closed or with segment cutout
- Open or sealed
- Relubrication facility



KN..-B-PP, KN..-B

Dimension table - Dimensions in mm

Designation				Mass m ≈g	Dimensions			Mounting dimensions	
					F _w	D	L	B ₂ ²⁾	L ₂
KN12-B-PP	KN12-B	-	-	20	12	22	32	-	22,6
-	-	KNO12-B-PP	KNO12-B					6,5	-
KN16-B-PP	KN16-B	-	-	30	16	26	36	-	24,6
-	-	KNO16-B-PP	KNO16-B					9	-
KN20-B-PP	KN20-B	-	-	60	20	32	45	-	31,2
-	-	KNO20-B-PP	KNO20-B					9	-
KN25-B-PP	KN25-B	-	-	130	25	40	58	-	43,7
-	-	KNO25-B-PP	KNO25-B					11,5	-
KN30-B-PP	KN30-B	-	-	190	30	47	68	-	51,7
-	-	KNO30-B-PP	KNO30-B					14	-
KN40-B-PP	KN40-B	-	-	350	40	62	80	-	60,3
-	-	KNO40-B-PP	KNO40-B					19	-
KN50-B-PP	KN50-B	-	-	670	50	75	100	-	77,3
-	-	KNO50-B-PP	KNO50-B					22,5	-

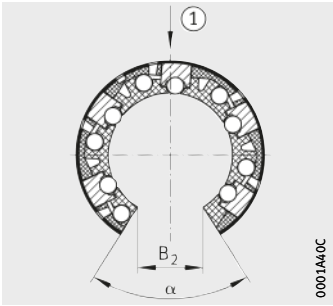
1) The basic load ratings are only valid for hardened (670 HV + 165 HV) and ground shaft raceways.

2) Dimension B₂ on diameter F_w.

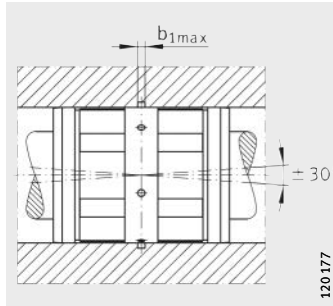
3) Hole position symmetrical to bearing length L.

4) Basic load rating in main load direction.

5) ① Main load direction



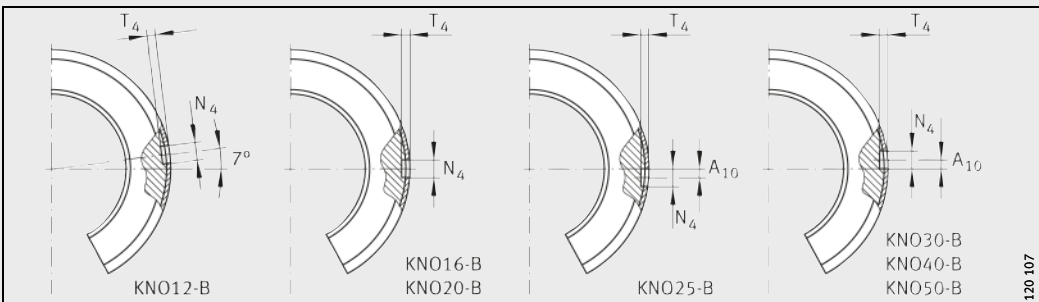
KNO...-B-PP, KNO...-B
① 5)



Self-aligning up to $\pm 30'$



B _{L2}	D _N	T ₄	A ₁₀	N ₄ ³⁾	α °	Ball rows		Basic load ratings ¹⁾			
						b _{1 max}	Quantity	dyn. C _{min} N	stat. C _{0 min} N	dyn. C _{max} N	stat. C _{0 max} N
1,3	21	0,7	-	3	-	1,5	5	730	510	870	740
-	-				66		4	-	-	840 ⁴⁾	640 ⁴⁾
1,3	25	0,7	-	3	-	1,5	5	870	620	1 040	910
-	-				68		4	-	-	1 000 ⁴⁾	750 ⁴⁾
1,6	30,7	0,9	-	3	-	2,5	6	1 730	1 230	1 830	1 570
-	-				55		5	-	-	1 740 ⁴⁾	1 240 ⁴⁾
1,85	38,5	1,4	-	3	-	2,5	6	3 100	2 220	3 250	2 850
-	-		1,5		5		-	-	3 100 ⁴⁾	2 260 ⁴⁾	
1,85	44,7	2,2	-	3	-	2,5	6	3 750	2 850	3 950	3 650
-	-		2		5		-	-	3 750 ⁴⁾	2 850 ⁴⁾	
2,15	59,4	2,2	-	3	-	3	6	6 300	4 350	6 700	5 600
-	-		1,5		5		-	-	6 300 ⁴⁾	4 350 ⁴⁾	
2,65	71,4	2,3	-	5	-	3	6	9 300	6 500	9 800	8 300
-	-		2,5		5		-	-	9 300 ⁴⁾	6 500 ⁴⁾	

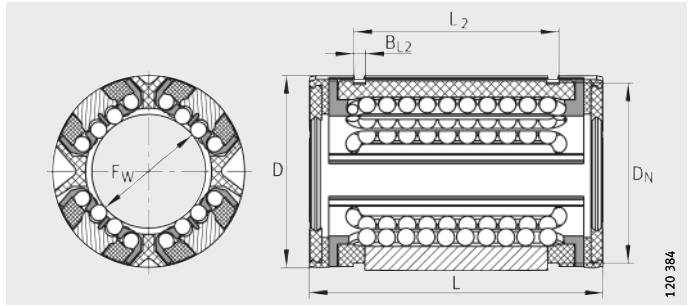


Fixing holes

Heavy duty range

Linear ball bearings

- Self-aligning
- Closed or with segment cutout
- Open or sealed
- Relubrication facility

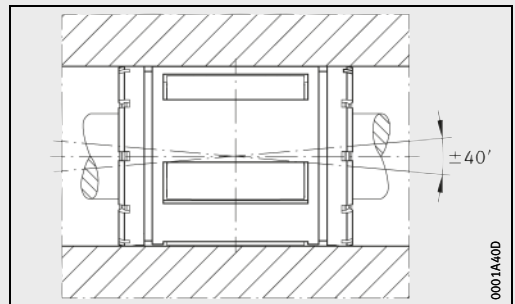


KS, KS..-PP

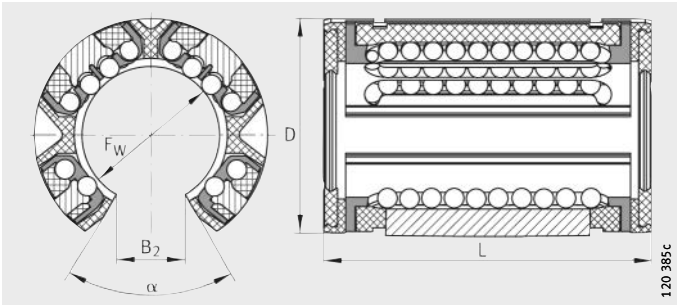
Dimension table - Dimensions in mm

Designation				Mass m ≈g	Dimensions			Mounting dimensions		
3)	4)	3)	4)		F _w	D	L	B ₂ ⁵⁾	L ₂	B _{L2}
KS12	KS12-PP	-	-	18	12	22	32	-	22,6	1,3
-	-	KS012	KS012-PP	13				7,6	-	-
KS16	KS16-PP	-	-	28	16	26	36	-	24,6	1,3
-	-	KS016	KS016-PP	19				10,1	-	-
KS20	KS20-PP	-	-	51	20	32	45	-	31,2	1,6
-	-	KS020	KS020-PP	38				10	-	-
KS25	KS25-PP	-	-	102	25	40	58	-	43,7	1,85
-	-	KS025	KS025-PP	75				12,5	-	-
KS30	KS30-PP	-	-	172	30	47	68	-	51,7	1,85
-	-	KS030	KS030-PP	135				14,3	-	-
KS40	KS40-PP	-	-	335	40	62	80	-	60,3	2,15
-	-	KS040	KS040-PP	259				18,2	-	-
KS50	KS50-PP	-	-	589	50	75	100	-	77,3	2,65
-	-	KS050	KS050-PP	454				22,7	-	-

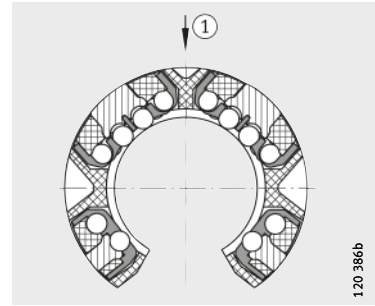
- 1) The basic load ratings are only valid for hardened (670 HV + 165 HV) and ground shaft raceways.
- 2) Basic load rating in main load direction.
- 3) With preservative, gap seals on both sides.
- 4) With initial greasing, contact seals on both sides.
- 5) Dimension B₂ on diameter F_w.
- 6) Hole position symmetrical to bearing length L.
- 7) Only one lubrication and fixing hole each in size 16 and 20.
- 8) ① Main load direction



Self-aligning up to ±40'

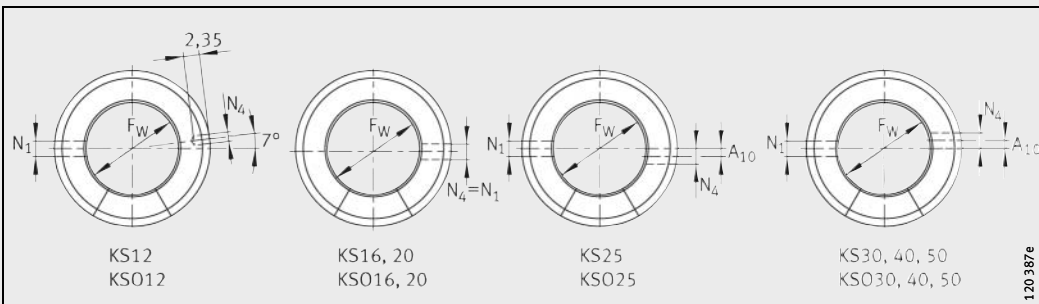


KSO, KSO..-PP



KSO, KSO..-PP
① 8)

D _N	A ₁₀	N ₁ ⁶⁾	N ₄ ⁶⁾	α °	Ball rows Quantity	Basic load ratings ¹⁾			
						dyn. C _{min} N	stat. C _{0 min} N	dyn. C _{max} N	stat. C _{0 max} N
21	-	-	3	-	8	630	600	900	1 100
-		3		78	6	-	-	900 ²⁾	1 100 ²⁾
25	-	3 ⁷⁾	3 ⁷⁾	-	8	1 060	950	1 430	1 550
-				78	6	-	1 430 ²⁾	1 550 ²⁾	
30,7	-	3 ⁷⁾	3 ⁷⁾	-	8	1 780	1 600	2 200	2 310
-				60	6	-	2 200 ²⁾	2 310 ²⁾	
38	1,5	3,5	3	-	8	2 700	2 430	3 950	4 300
-				60	6	-	3 950 ²⁾	4 300 ²⁾	
44,7	2	3,5	3	-	8	4 650	3 970	5 900	6 000
-				57	6	-	5 900 ²⁾	6 000 ²⁾	
59,4	1,5	3,5	3	-	8	8 800	7 200	10 200	9 600
-				54	6	-	10 200 ²⁾	9 600 ²⁾	
71,4	2,5	4,5	5	-	8	12 300	9 700	15 100	13 900
-				54	6	-	15 100 ²⁾	13 900 ²⁾	



Fixing holes⁷⁾

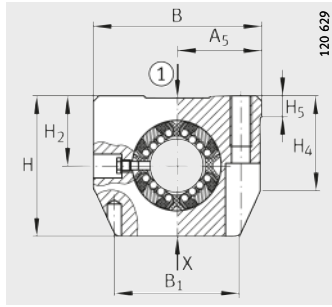
Heavy duty range

Linear ball bearing and housing units

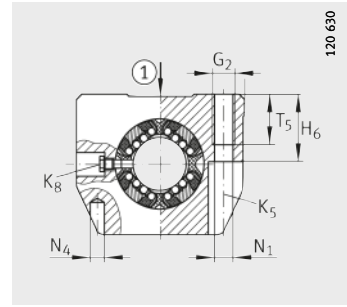
Closed or with slot

Sealed

Greased,
with relubrication facility



KGSNG...PP-AS, KGSNS...PP-AS
① 7)



KGSNG...PP-AS, KGSNS...PP-AS
① 7)

Dimension table - Dimensions in mm

Designation		Mass m ≈g	Dimensions				Mounting dimensions			
			F _W	B	L	H	J _B	B ₁	A ₅	J _L ³⁾
KGSNG12-PP-AS	-	110	12	43	32	35	32	34	21,5	23
-	KGSNS12-PP-AS	100								
KGSNG16-PP-AS	-	220	16	53	37	42	40	40	26,5	26
-	KGSNS16-PP-AS	200								
KGSNG20-PP-AS	-	370	20	60	45	50	45	44	30	32
-	KGSNS20-PP-AS	360								
KGSNG25-PP-AS	-	630	25	78	58	60	60	59,4	39	40
-	KGSNS25-PP-AS	550								
KGSNG30-PP-AS	-	890	30	87	68	70	68	63	43,5	45
-	KGSNS30-PP-AS	730								
KGSNG40-PP-AS	-	1300	40	108	80	90	86	76	54	58
-	KGSNS40-PP-AS	1350								
KGSNG50-PP-AS	-	2200	50	132	100	105	108	90	66	50
-	KGSNS50-PP-AS	2250								

1) The basic load ratings are only valid for hardened (670 HV + 165 HV) and ground shaft raceways.

2) Basic load rating in main load direction.

3) Dimension J_L and lubrication hole symmetrical to the bearing length L.

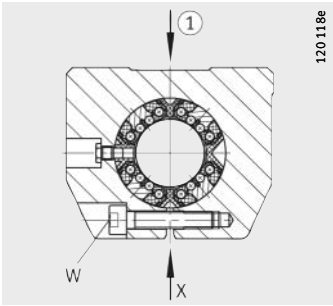
4) Centring for dowel hole.

5) For fixing screws ISO 4762-8.8.

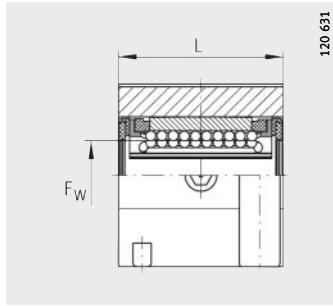
If there is a possibility of settling, the screws should be secured against rotation.

6) Lubrication nipple. Designs and dimensions, see page 30.

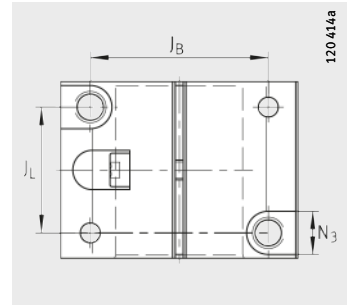
7) ① Main load direction



KGSNS...-PP-AS
① 7)



KGSNG...-PP-AS, KGSNS...-PP-AS



KGSNS...-PP-AS

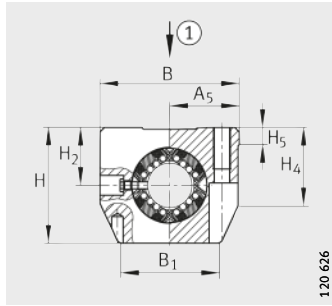


												Ball rows	Basic load ratings ¹⁾²⁾	
H ₂	H ₅	H ₄	T ₅	H ₆	G ₂	N ₁	N ₄ ⁴⁾	N ₃	K ₅ ⁵⁾	K ₈ ³⁾⁶⁾	Width across flats W		Quantity	dyn. C _{max}
+0,008 -0,016													N	N
18	5,4	26,6	11	16,5	M5	4,3	4	8	M4	NIP4MZ	— 2,5	8	900	1 100
22	6,9	29,3	13	21	M6	5,3	4	10	M5	NIP4MZ	— 3	8	1 430	1 550
25	7,4	34,1	18	24	M8	6,6	5	11	M6	NIP4MZ	— 4	8	2 200	2 310
30	8,3	41,5	22	29	M10	8,4	6	15	M8	NIP5MZ	— 5	8	3 950	4 300
35	9,3	46,2	22	34	M10	8,4	6	15	M8	NIP5MZ	— 5	8	5 900	6 000
45	11,7	57,6	26	44	M12	10,5	8	18	M10	NIP5MZ	— 6	8	10 200	9 600
50	10,6	62	35	49	M16	13,5	10	20	M12	NIP6MZ	— 8	8	15 100	13 900

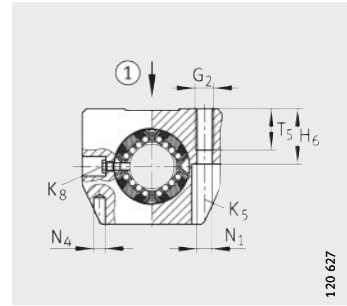
Heavy duty range

Linear ball bearing and housing units

- Tandem arrangement
- Closed or with slot
- Sealed
- Greased,
with relubrication facility



KTSG...-PP-AS, KTSS...-PP-AS
① 7)



KTSG...-PP-AS, KTSS...-PP-AS
① 7)

Dimension table - Dimensions in mm

Designation		Mass m ≈g	Dimensions				Mounting dimensions				
			F _W	B	L	H	J _B	B ₁	A ₅	J _L ³⁾	L ₆ ³⁾
KTSG12-PP-AS	-	210	12	43	70	35	32	34	21,5	56	24
-	KTSS12-PP-AS										
KTSG16-PP-AS	-	380	16	53	78	42	40	40	26,5	64	26
-	KTSS16-PP-AS										
KTSG20-PP-AS	-	550	20	60	96	50	45	44	30	76	33
-	KTSS20-PP-AS										
KTSG25-PP-AS	-	1130	25	78	122	60	60	59,4	39	94	44
-	KTSS25-PP-AS										
KTSG30-PP-AS	-	1780	30	87	142	70	68	63	43,5	106	54
-	KTSS30-PP-AS										

1) The basic load ratings are only valid for hardened (670 HV + 165 HV) and ground shaft raceways.

2) Basic load rating in main load direction.

3) Dimensions J_L, L₆ and lubrication hole symmetrical to the bearing length L.

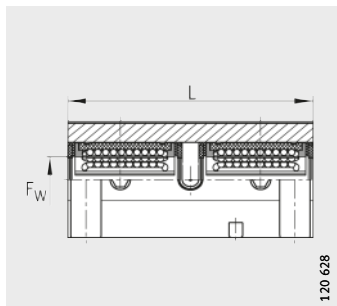
4) Centring for dowel hole.

5) For fixing screws ISO 4762-8.8.

If there is a possibility of settling, the screws should be secured against rotation.

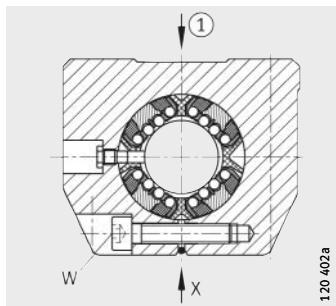
6) Lubrication nipple. Designs and dimensions, see page 30.

7) ① Main load direction



KTSG...-PP-AS, KTSS...-PP-AS

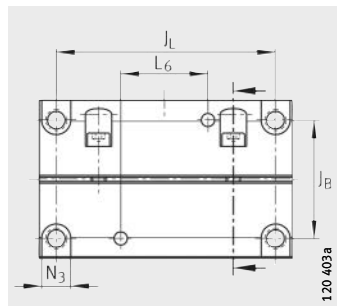
120 628



KTSS...-PP-AS

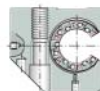
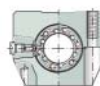
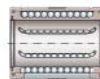
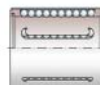
① 7)

120 402a



KTSS...-PP-AS

120 403a

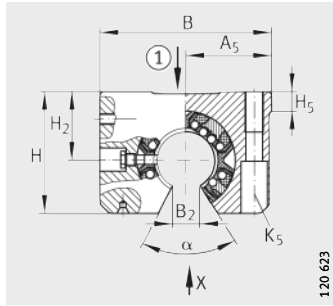


												Ball rows	Basic load ratings ¹⁾²⁾		
H ₂	H ₅	H ₄	T ₅	H ₆	G ₂	N ₁	N ₄ ⁴⁾	N ₃	K ₅ ⁵⁾	K ₈ ³⁾⁶⁾	Width across flats W		Quantity	dyn. C _{max}	stat. C _{0 max}
+0,008 -0,016															
18	5,4	26,6	11	16,5	M5	4,3	4	8	M4	NIP4MZ	- 2,5	8	1 460	2 100	
22	6,9	29,3	13	21	M6	5,3	4	10	M5	NIP4MZ	- 3	8	2 330	3 100	
25	7,4	34,1	18	24	M8	6,6	5	11	M6	NIP4MZ	- 4	8	3 500	4 600	
30	8,3	41,5	22	29	M10	8,4	6	15	M8	NIP5MZ	- 5	8	6 400	8 600	
35	9,3	46,2	22	34	M10	8,4	6	15	M8	NIP5MZ	- 5	8	9 600	12 000	

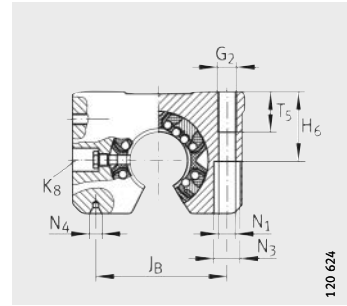
Heavy duty range

Linear ball bearing and housing units

- With segment cutout
- With or without slot
- Sealed
- Greased, with relubrication facility



Starting KGSNO16-PP-AS, KGSNOS16-PP-AS
① 8)



Starting KGSNO16-PP-AS, KGSNOS16-PP-AS

Dimension table · Dimensions in mm

Designation		Mass m ≈g	Dimensions				Mounting dimensions			
			F _w	B	L	H	J _B	A ₅	B ₂ ³⁾	J _L ⁴⁾
KGSNO12-PP-AS	–	80	12	43	32	28	32	21,5	7,6	23
–	KGSNOS12-PP-AS	90								
KGSNO16-PP-AS	–	150	16	53	37	35	40	26,5	10,1	26
–	KGSNOS16-PP-AS	150								
KGSNO20-PP-AS	–	200	20	60	45	42	45	30	10	32
–	KGSNOS20-PP-AS	250								
KGSNO25-PP-AS	–	410	25	78	58	51	60	39	12,5	40
–	KGSNOS25-PP-AS	520								
KGSNO30-PP-AS	–	600	30	87	68	60	68	43,5	14,3	45
–	KGSNOS30-PP-AS	760								
KGSNO40-PP-AS	–	1 100	40	108	80	77	86	54	18,2	58
–	KGSNOS40-PP-AS	1 400								
KGSNO50-PP-AS	–	2 870	50	132	100	88	108	66	22,7	50
–	KGSNOS50-PP-AS	2 670								

1) The basic load ratings are only valid for hardened (670 HV + 165 HV) and ground shaft raceways.

2) Basic load rating in main load direction.

3) Dimension B₂ on diameter F_w.

4) Dimension J_L and lubrication hole symmetrical to the bearing length L.

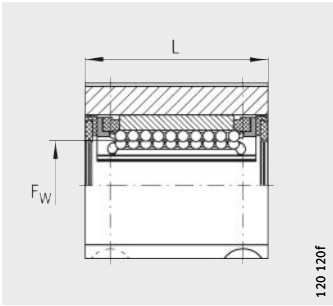
5) Centring hole DIN 332 type A.

6) For fixing screws ISO 4762-8.8.

If there is a possibility of settling, the screws should be secured against rotation.

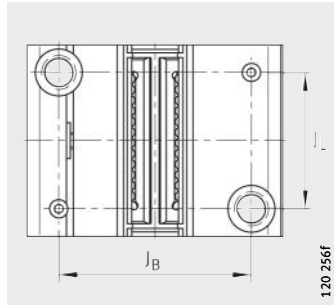
7) Lubrication nipple. Designs and dimensions, see page 30.

8) ① Main load direction



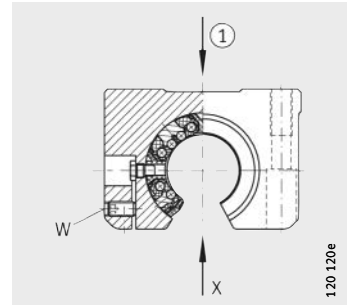
120 120f

KGSNO...-PP-AS, KGSNOS...-PP-AS



120 256f

KGSNOS...-PP-AS
View X

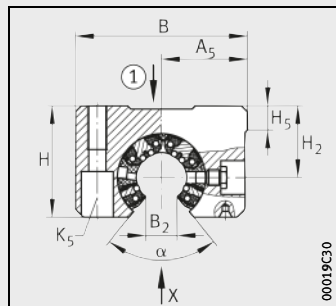


120 120e

Starting KGSNOS16-PP-AS
①⁸⁾

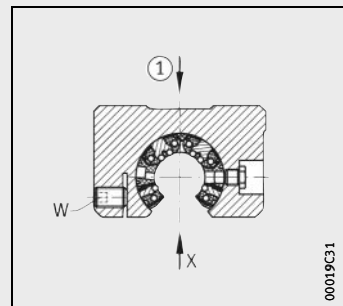


H ₂	H ₅	T ₅	H ₆	G ₂	N ₁	N ₄ ⁵⁾	N ₃	K ₅ ⁶⁾	K ₈ ^{4) 7)}	Width across flats W	α	Ball rows Quantity	Basic load ratings ^{1) 2)}		
													dyn. C _{max} N	stat. C _{0 max} N	
+0,008 -0,016															
18	6,1	11	16,5	M5	4,3	1,6×3,35	8	M4	NIP4MZ	— 2,5	78	6	900	1 100	
22	7,5	13	21	M6	5,3	1,6×3,35	10	M5	NIP4MZ	— 2,5	68	6	1 430	1 550	
25	8	18	24	M8	6,6	2×4,25	11	M6	NIP4MZ	— 2,5	55	6	2 200	2 310	
30	8,8	22	29	M10	8,4	2,5×5,3	15	M8	NIP5MZ	— 3	57	6	3 950	4 300	
35	9,7	22	34	M10	8,4	2,5×5,3	15	M8	NIP5MZ	— 3	57	6	5 900	6 000	
45	12,4	26	44	M12	10,5	3,15×6,7	18	M10	NIP5MZ	— 4	56	6	10 200	9 600	
50	11,1	35	49	M16	13,5	4×8,5	20	M12	NIP5MZ	— 5	54	6	15 100	13 900	



00019C30

KGSNO12-PP-AS,
KGSNOS12-PP-AS



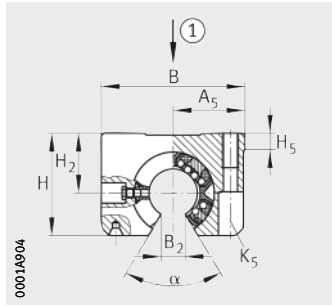
00019C31

KGSNOS12-PP-AS

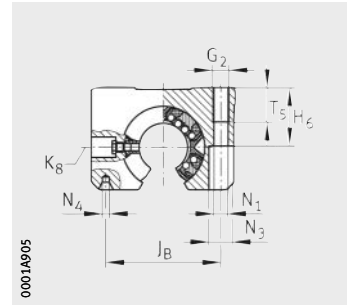
Heavy duty range

Linear ball bearing and housing units

- Tandem arrangement
- With segment cutout
- With or without slot
- Sealed
- Greased, with relubrication facility



KTSO...-PP-AS
① 8)



KTSO...-PP-AS

Dimension table - Dimensions in mm

Designation		Mass m ≈g	Dimensions				Mounting dimensions			
			F _w	B	L	H	J _B	A ₅	B ₂ ³⁾	J _L ⁴⁾
KTSO12-PP-AS	-	190	12	43	70	28	32	21,5	7,6	56
-	KTSO512-PP-AS									
KTSO16-PP-AS	-	320	16	53	78	35	40	26,5	10,1	64
-	KTSO516-PP-AS									
KTSO20-PP-AS	-	520	20	60	96	42	45	30	10	76
-	KTSO520-PP-AS									
KTSO25-PP-AS	-	1060	25	78	122	51	60	39	12,5	94
-	KTSO525-PP-AS									
KTSO30-PP-AS	-	1550	30	87	142	60	68	43,5	14,3	106
-	KTSO530-PP-AS									

1) The basic load ratings are only valid for hardened (670 HV + 165 HV) and ground shaft raceways.

2) Basic load rating in main load direction.

3) Dimension B₂ on diameter F_w.

4) Dimensions J_L, L₆ and lubrication hole symmetrical to the bearing length L.

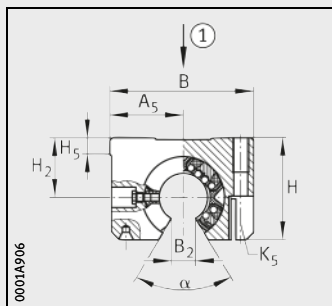
5) Centring hole DIN 332 type A.

6) For fixing screws ISO 4762-8.8.

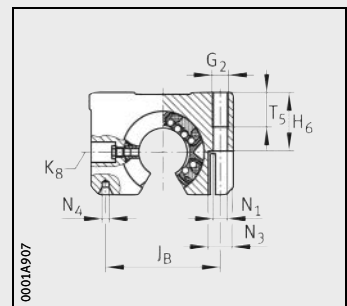
If there is a possibility of settling, the screws should be secured against rotation.

7) Lubrication nipple. Designs and dimensions, see page 30.

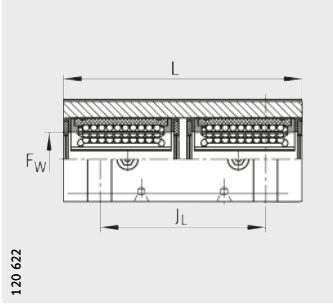
8) ① Main load direction



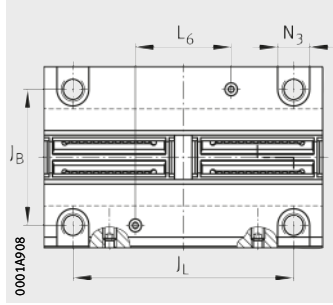
KTSOS...-PP-AS
① 8)



KTSOS...-PP-AS



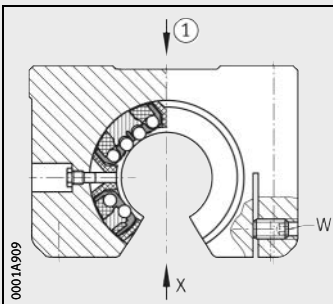
KTSO...-PP-AS, KTSOS...-PP-AS



KTSO...-PP-AS
View X



L ₆ ⁴⁾	H ₂ +0,008 -0,016	H ₅	T ₅	H ₆	G ₂	N ₁	N ₄ ⁵⁾	N ₃	K ₅ ⁶⁾	K ₈ ⁴⁾⁷⁾	Width across flats W	α °	Ball rows Quantity	Basic load ratings ¹⁾²⁾	
														dyn. C _{max} N	stat. C _{0 max} N
24	18	6,1	11	16,5	M5	4,3	1,6×3,35	8	M4	NIP4MZ	— 2,5	66	6	1 460	2 100
26	22	7,5	13	21	M6	5,3	1,6×3,35	10	M5	NIP4MZ	— 2,5	68	6	2 330	3 100
33	25	8	18	24	M8	6,6	2×4,25	11	M6	NIP4MZ	— 2,5	55	6	3 500	4 600
44	30	8,8	22	29	M10	8,4	2,5×5,3	15	M8	NIP5MZ	— 3	57	6	6 400	8 600
54	35	9,7	22	34	M10	8,4	2,5×5,3	15	M8	NIP5MZ	— 3	57	6	9 600	12 000



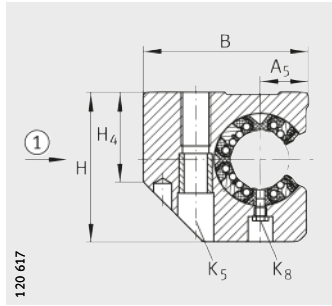
KTSOS...-PP-AS

① 8)

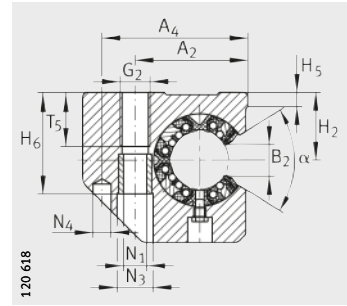
Heavy duty range

Linear ball bearing and housing units

Lateral segment cutout
 With or without slot
 Sealed
 Greased,
 with relubrication facility



KGSC...-PP-AS, KGSCS...-PP-AS
 ① 8)



KGSC...-PP-AS, KGSCS...-PP-AS

Dimension table - Dimensions in mm

Designation		Mass m ≈g	Dimensions				Mounting dimensions					
			F _w	B	L	H	A ₂	A ₄	A ₅	B ₂ ³⁾	J _L ⁴⁾	L ₆ ⁴⁾
KGSC20-PP-AS	-	350	20	60	47	60	39	51	17	10	30	36
-	KGSCS20-PP-AS											
KGSC25-PP-AS	-	680	25	75	58	72	49	64	21	12,5	36	45
-	KGSCS25-PP-AS											
KGSC30-PP-AS	-	1000	30	86	68	82	59	76	25	14,3	42	52
-	KGSCS30-PP-AS											
KGSC40-PP-AS	-	1800	40	110	80	100	75	97	32	18,2	48	60
-	KGSCS40-PP-AS											
KGSC50-PP-AS	-	2900	50	127	100	115	88	109	38	22,7	62	80
-	KGSCS50-PP-AS											

1) The basic load ratings are only valid for hardened (670 HV + 165 HV) and ground shaft raceways.

2) Basic load rating in main load direction.

3) Dimension B₂ on diameter F_w.

4) Dimensions J_L, L₆ and lubrication hole symmetrical to the bearing length L.

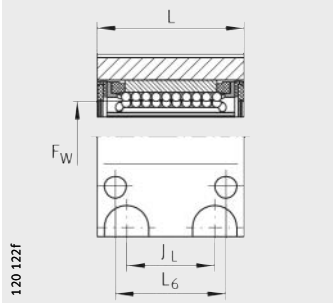
5) Centring for dowel hole.

6) For fixing screws ISO 4762-8.8.

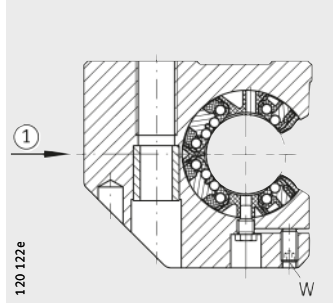
If there is a possibility of settling, the screws should be secured against rotation.

7) Lubrication nipple. Designs and dimensions, see page 30.

8) ① Main load direction



KGSC...-PP-AS, KGSCS...-PP-AS



KGSCS...-PP-AS
①⁸⁾



													Ball rows	Basic load ratings ¹⁾²⁾	
H ₂	H ₅	H ₄	T ₅	H ₆	G ₂	N ₁	N ₄ ⁵⁾	N ₃	K ₅ ⁶⁾	K ₈ ⁴⁾⁷⁾	Width across flats W	α		Quantity	dyn. C _{max}
+0,008 -0,016												°			N
30	8,3	37,5	18	42,6	M10	8,4	6	15	M8	NIP4MZ	— 2,5	55	6	2 200	2 310
35	8,2	45	22	50,6	M12	10,5	8	18	M10	NIP5MZ	— 3	57	6	3 950	4 300
40	9	52	29	55,6	M16	13,5	10	20	M12	NIP5MZ	— 3	57	6	5 900	6 000
45	9,5	60	36	67,6	M20	15,5	12	24	M14	NIP5MZ	— 4	56	6	10 200	9 600
50	8,6	70	36	78,8	M20	17,5	12	26	M16	NIP6MZ	— 5	54	6	15 100	13 900

Heavy duty range

Linear ball bearing and housing units

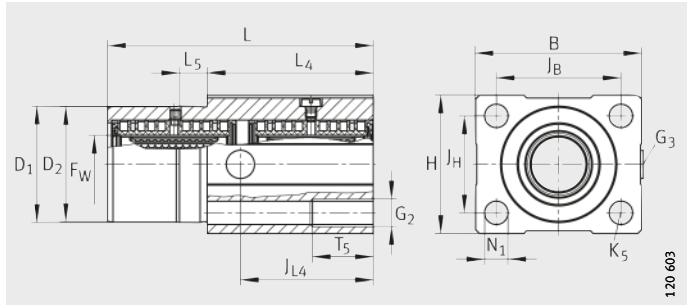
Centring collar

Tandem arrangement

Sealed

Greased,

with relubrication facility



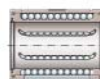
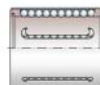
KTFS..-PP-AS

Dimension table - Dimensions in mm

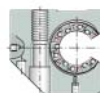
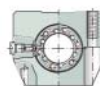
Designation	Mass m ≈g	Dimensions				Mounting dimensions		
		FW	B	L	H	JB ±0,15	L4	L5
KTFS12-PP-AS	180	12	42	70	34	32	46	10
KTFS16-PP-AS	260	16	50	78	40	38	50	10
KTFS20-PP-AS	550	20	60	96	50	45	60	10
KTFS25-PP-AS	700	25	74	122	60	56	73	10
KTFS30-PP-AS	1 100	30	84	142	70	64	82	10

1) The basic load ratings are only valid for hardened (670 HV + 165 HV) and ground shaft raceways.

2) Recommended locating bore for D₁ = H7.



J _{L4}	D ₁ ²⁾ g7	D ₂ -0,1 -0,3	J _H ±0,15	T ₅	G ₂	N ₁	K ₅	G ₃	Ball rows Quantity	Basic load ratings ¹⁾	
										dyn. C _{min} N	stat. C _{0 min} N
35	30	30	24	13	M6	5,3	M5	M8×1	8	1 020	1 200
39	35	35	28	18	M8	6,6	M6	M8×1	8	1 790	1 900
48	42	42	35	22	M10	8,4	M8	M8×1	8	3 100	3 200
61	52	52	42	26	M12	10,5	M10	M8×1	8	4 400	4 850
71	61	61	50	35	M16	13,5	M12	M8×1	8	7 550	7 900



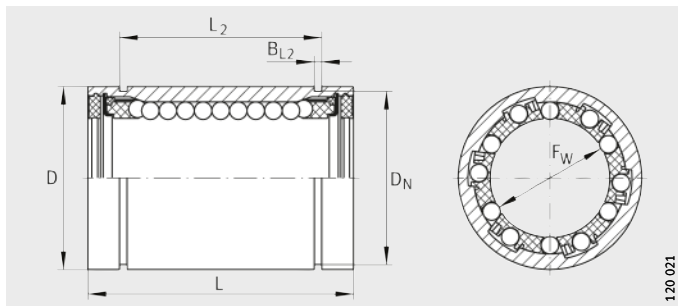
Machined range

Linear ball bearings

Closed, slotted or with segment cutout

Open or sealed

Not greased, greased, with relubrication facility



KB

Dimension table - Dimensions in mm

Designation			Mass m ≈g	Dimensions			Mounting dimensions			
3)	4)	5)		F _w	D ⁶⁾ h5	L h12	B ₂ ⁷⁾	L ₂ H13	B _{L2} ⁸⁾	
				Tolerances ⁶⁾						
KB12	KB12-PP	KB12-PP-AS	40	12	+0,008 0	22	32	-	22,6	1,3
KBS12	KBS12-PP	KBS12-PP-AS						7,7		
KBO12	KBO12-PP	KBO12-PP-AS						30		
KB16	KB16-PP	KB16-PP-AS	50	16	+0,009 -0,001	26	36	-	24,6	1,3
KBS16	KBS16-PP	KBS16-PP-AS						10,1		
KBO16	KBO16-PP	KBO16-PP-AS						40		
KB20	KB20-PP	KB20-PP-AS	90	20	+0,009 -0,001	32	45	-	31,2	1,6
KBS20	KBS20-PP	KBS20-PP-AS						10		
KBO20	KBO20-PP	KBO20-PP-AS						70		
KB25	KB25-PP	KB25-PP-AS	190	25	+0,011 -0,001	40	58	-	43,7	1,85
KBS25	KBS25-PP	KBS25-PP-AS						12,5		
KBO25	KBO25-PP	KBO25-PP-AS						150		
KB30	KB30-PP	KB30-PP-AS	300	30	+0,011 -0,001	47	68	-	51,7	1,85
KBS30	KBS30-PP	KBS30-PP-AS						13,6		
KBO30	KBO30-PP	KBO30-PP-AS						240		
KB40	KB40-PP	KB40-PP-AS	600	40	+0,013 -0,002	62	80	-	60,3	2,15
KBS40	KBS40-PP	KBS40-PP-AS						18,2		
KBO40	KBO40-PP	KBO40-PP-AS						520		
KB50	KB50-PP	KB50-PP-AS	1000	50	+0,013 -0,002	75	100	-	77,3	2,65
KBS50	KBS50-PP	KBS50-PP-AS						22,7		
KBO50	KBO50-PP	KBO50-PP-AS						850		

1) The basic load ratings are only valid for hardened (670 HV + 165 HV) and ground shaft raceways.

2) Basic load rating in main load direction.

3) With preservative.

4) With initial greasing, sealed on both sides.

5) With initial greasing, sealed on both sides, with relubrication facility.

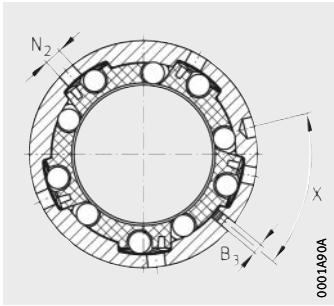
6) The tolerances are only valid for KB.

7) Dimension B₂ on diameter F_w.

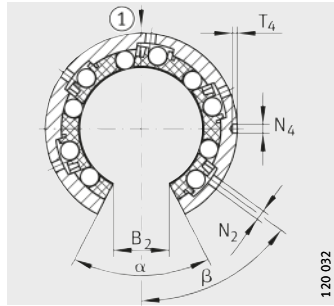
8) Slot dimensions suitable for retaining rings to DIN 471.

9) Hole position symmetrical to bearing length L.

10) ① Main load direction



KBS..-PP-AS



KBO..-PP-AS
① 10)

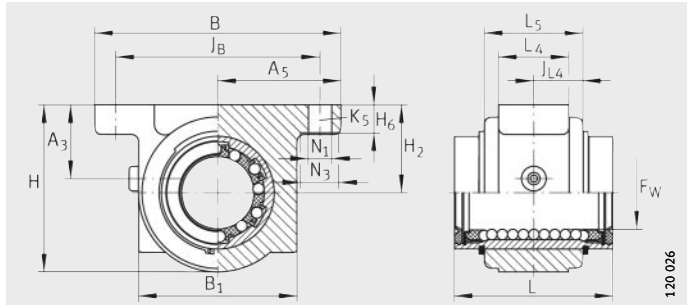


B ₃	D _N ⁸⁾	T ₄	N ₄ ⁹⁾	N ₂	α	β	X	Ball rows Quantity	Basic load ratings ¹⁾			
									dyn. C _{min} N	stat. C _{0 min} N	dyn. C _{max} N	stat. C _{0 max} N
-	21	-	-	1,5	-	-	-	5	540	385	640	570
1		1,2	2,2		78	64	-					
-	24,9	-	-	2	-	-	-	5	710	530	840	780
1		1,2	2,2		78	64	-					
-	30,3	-	-	2	-	-	-	6	1 570	1 230	1 660	1 570
1		1,2	2,2		60	52	-					
-	37,5	-	-	2,5	-	-	-	6	2 800	2 220	2 950	2 850
1		1,5	3		60	53	-					
-	44,5	-	-	2,5	-	-	-	6	3 600	2 850	3 800	3 600
1		1,5	3		54	55	-					
-	59	-	-	3	-	-	-	6	6 000	4 400	6 400	5 600
1		1,5	3		54	54	-					
-	72	-	-	4	-	-	-	6	8 700	6 300	9 200	8 000
1		1,5	3		54	54	-					

Machined range

Linear ball bearing and housing units

Closed, slotted or with segment cutout
Sealed
Greased,
with relubrication facility

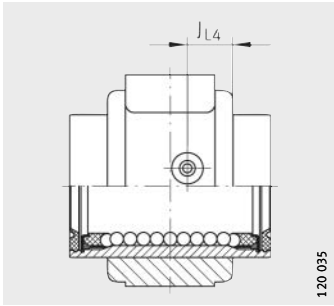


KGB..-PP-AS

Dimension table - Dimensions in mm

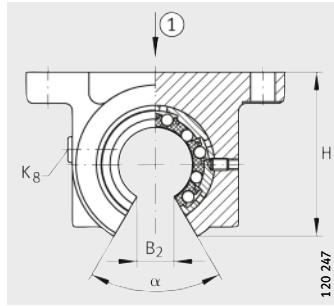
Designation			Mass m ≈g	Dimensions				Mounting dimensions				
				F _W		B	L	H	J _B	B ₁	A ₅	B ₂ ⁴⁾
				Tolerances ⁶⁾		h12						
KGB12-PP-AS	-	-	100	12	+0,008 0	52	32	35,8	42 ±0,15	31,6	26 ±0,02	-
-	KGBS12-PP-AS	-						32				7,7
-	-	KGB012-PP-AS	90									
KGB16-PP-AS	-	-	140	16	+0,009 -0,001	56	36	37,5	46 ±0,15	35	28 ±0,02	-
-	KGBS16-PP-AS	-						33,5				10,1
-	-	KGB016-PP-AS	120									
KGB20-PP-AS	-	-	300	20	+0,009 -0,001	70	45	47,5	58 ±0,15	45	35 ±0,02	-
-	KGBS20-PP-AS	-						45				10
-	-	KGB020-PP-AS	250									
KGB25-PP-AS	-	-	580	25	+0,011 -0,001	80	58	57,5	68 ±0,15	55	40 ±0,02	-
-	KGBS25-PP-AS	-						54,5				12,5
-	-	KGB025-PP-AS	490									
KGB30-PP-AS	-	-	900	30	+0,011 -0,001	88	68	66,5	76 ±0,2	63	44 ±0,02	-
-	KGBS30-PP-AS	-						63,5				13,6
-	-	KGB030-PP-AS	780									
KGB40-PP-AS	-	-	1 430	40	+0,013 -0,002	108	80	83,5	94 ±0,2	77	54 ±0,02	-
-	KGBS40-PP-AS	-						79,5				18,2
-	-	KGB040-PP-AS	1 280									
KGB50-PP-AS	-	-	2 780	50	+0,013 -0,002	135	100	98	116 ±0,2	96	67,5 ±0,02	-
-	KGBS50-PP-AS	-						93				22,7
-	-	KGB050-PP-AS	2 460									

- 1) Designs and dimensions, see page 31.
- 2) The basic load ratings are only valid for hardened (670 HV + 165 HV) and ground shaft raceways.
- 3) Basic load rating in main load direction.
- 4) Dimension B₂ on diameter F_W.
- 5) For fixing screws ISO 4762-8.8.
If there is a possibility of settling, the screws should be secured against rotation.
- 6) The tolerances are valid for KGB..-PP-AS.
- 7) ① Main load direction



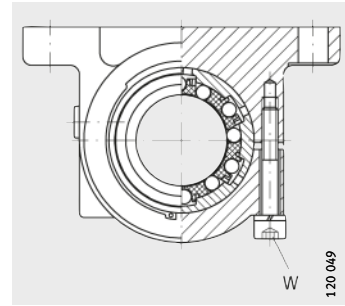
KGBO..-PP-AS

120 035



KGBO, KGBO..-PP-AS
① 7)

120 247



KGBS..-PP-AS

120 049



L ₅	L ₄	J _{L4}	H ₂ ±0,015	A ₃	H ₆	N ₁	N ₃	K ₅ ⁵⁾	α °	Width across flats W	Lubrication nipple ¹⁾ K ₈	Ball rows Quantity	Basic load ratings ²⁾	
													dyn. C N	stat. C ₀ N
20	12	10	20	15	6	5,5	10	M5	-	-	NIPA1	5	540	385
		6,5								78				
22	15	11	20	15	6	5,5	10	M5	-	-	NIPA1	5	710	530
		6,5								78				
28	20	14	25	21	8	6,6	11	M6	-	-	NIPA1	6	1 570	1 230
		9,5								60				
40	28	20	30	23	10	6,6	11	M6	-	-	NIPA1	6	2 800	2 220
		15								60				
48	32	24	35	25	10	6,6	11	M6	-	-	NIPA2	6	3 600	2 850
		19								54				
56	40	28	45	30	12	9	15	M8	-	-	NIPA2	6	6 000	4 400
		23								54				
72	52	36	50	34	14	11	18	M10	-	-	NIPA2	6	8 700	6 300
		28								54				

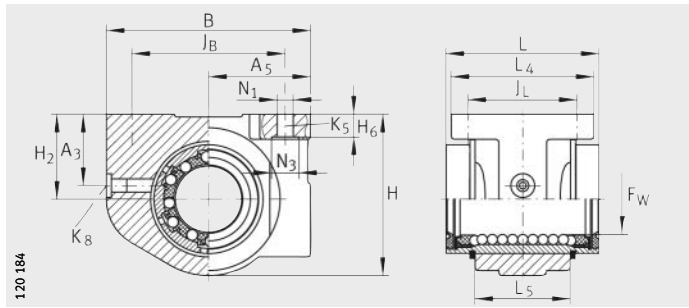
Machined range

Linear ball bearing and housing units

Closed, slotted or with segment cutout

Sealed

Greased, with relubrication facility



KGBA...PP-AS

Dimension table · Dimensions in mm

Designation			Mass m ≈g	Dimensions			Mounting dimensions					
				F _W		B	L	H	J _B	A ₅	B ₂ ⁴⁾	L ₄
				Tolerances ⁷⁾			h12					
KGBA12-PP-AS	–	–	80	12	+0,008 0	42	32	34	32±0,15	21±0,01	–	32
–	KGBAS12-PP-AS	–						30,5			7,7	
–	–	KGBAO12-PP-AS						70			–	
KGBA16-PP-AS	–	–	120	16	+0,009 –0,001	50	36	41	40±0,15	25±0,01	–	35
–	KGBAS16-PP-AS	–						37			10,1	
–	–	KGBAO16-PP-AS						100			–	
KGBA20-PP-AS	–	–	200	20	+0,009 –0,001	60	45	47,5	45±0,15	30±0,01	–	42
–	KGBAS20-PP-AS	–						44,5			10	
–	–	KGBAO20-PP-AS						170			–	
KGBA25-PP-AS	–	–	410	25	+0,011 –0,001	74	58	60	60±0,2	37±0,01	–	54
–	KGBAS25-PP-AS	–						56			12,5	
–	–	KGBAO25-PP-AS						350			–	
KGBA30-PP-AS	–	–	610	30	+0,011 –0,001	84	68	67	68±0,2	42±0,01	–	60
–	KGBAS30-PP-AS	–						63,5			13,6	
–	–	KGBAO30-PP-AS						530			–	
KGBA40-PP-AS	–	–	1 200	40	+0,013 –0,002	108	80	87	86±0,2	54±0,015	–	78
–	KGBAS40-PP-AS	–						82,5			18,2	
–	–	KGBAO40-PP-AS						1 070			–	
KGBA50-PP-AS	–	–	1 880	50	+0,013 –0,002	130	100	98	108±0,2	65±0,015	–	70
–	KGBAS50-PP-AS	–						93			22,7	
–	–	KGBAO50-PP-AS						1 650			–	

1) Designs and dimensions, see page 31.

2) The basic load ratings are only valid for hardened (670 HV + 165 HV) and ground shaft raceways.

3) Basic load rating in main load direction.

4) Dimension B₂ on diameter F_W.

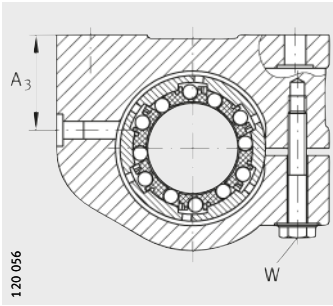
5) For fixing screws ISO 4762-8.8.

If there is a possibility of settling, the screws should be secured against rotation.

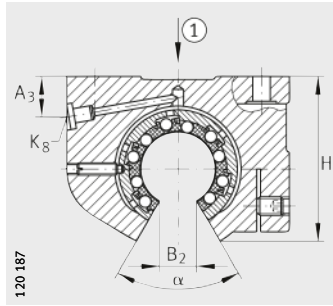
6) Note maximum tightening torques.

7) The tolerances are valid for KGBA...PP-AS.

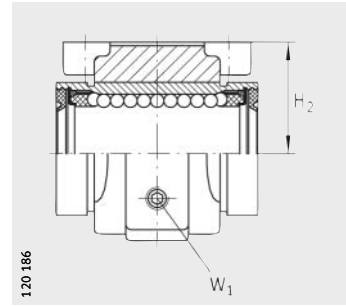
8) ① Main load direction



KGBAS...-PP-AS



KGBAO...-PP-AS
① 8)



KGBAO...-PP-AS

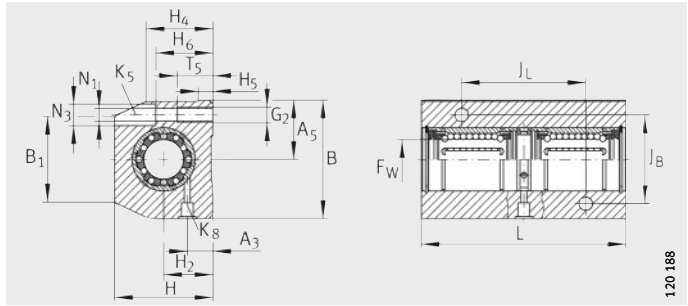
J _L	L ₅	H ₂	A ₃	H ₆ -0,5	N ₁	N ₃	K ₅ ⁵⁾	α °	Width across flats			K ₈	Ball rows Quantity	Basic load ratings ²⁾	
									W	W ₁ ⁶⁾				dyn. C N	stat. C ₀ N
										max. Nm					
23±0,15	20	18±0,01	15	4,8	4,7	8	M4	-	-	-	-	NIPA1	5	540	385
			7,8						7	2	1				
26±0,15	22	22±0,01	15	5,4	4,7	8	M4	-	-	-	-	NIPA1	5	710	530
			10						7	2,5	1,5				
32±0,15	28	25±0,01	21	6,7	4,7	8	M4	-	-	-	-	NIPA1	6	1 570	1 230
			11						7	2,5	1,5				
40±0,2	40	30±0,01	23	7,8	5,7	10	M5	-	-	-	-	NIPA1	6	2 800	2 220
			13						8	3	3				
45±0,2	48	35±0,01	25	8,7	6,8	11	M6	-	-	-	-	NIPA2	6	3 600	2 850
			14						10	3	4				
58±0,2	56	45±0,01	30	11	9,2	15	M8	-	-	-	-	NIPA2	6	6 000	4 400
			18						13	4	5				
50±0,2	72	50±0,015	34	12,5	9,2	15	M8	-	-	-	-	NIPA2	6	8 700	6 300
			19						13	4	7				



Machined range

Linear ball bearing and housing units

- Tandem arrangement
- Closed or with segment cutout
- Sealed
- Greased,
with relubrication facility



KTB...PP-AS

Dimension table - Dimensions in mm

Designation		Mass m ≈g	Dimensions				Mounting dimensions					
			F _W	B	L	H	J _B	A ₅	B ₁	B ₂ ³⁾	J _L ⁴⁾	H ₂
KTB12-PP-AS	-	310	12	43	76	35	30	21,5	34	-	40	18
-	KTBO12-PP-AS	260		+0,008 0		42		30	-	-		
KTB16-PP-AS	-	460	16	53	84	42	36	26,5	40	-	45	22
-	KTBO16-PP-AS	360		+0,009 -0,001		50		35	-	-		
KTB20-PP-AS	-	800	20	60	104	50	45	30	44	-	55	25
-	KTBO20-PP-AS	620		+0,009 -0,001		60		42	-	-		
KTB25-PP-AS	-	1 490	25	78	130	60	54	39	60	-	70	30
-	KTBO25-PP-AS	1 180		+0,011 -0,001		74		51	-	-		
KTB30-PP-AS	-	2 300	30	87	152	70	62	43,5	63	-	85	35
-	KTBO30-PP-AS	1 840		+0,011 -0,001		84		60	-	-		
KTB40-PP-AS	-	3 700	40	108	176	90	80	54	76	-	100	45
-	KTBO40-PP-AS	3 000		+0,013 -0,002		108		77	-	-		
KTB50-PP-AS	-	6 600	50	132	224	105	100	66	90	-	125	50
-	KTBO50-PP-AS	5 100		+0,013 -0,002		130		88	-	-		

1) The basic load ratings are only valid for hardened (670 HV + 165 HV) and ground shaft raceways and where the two linear ball bearings are subjected to equal loading.

2) Basic load rating in main load direction.

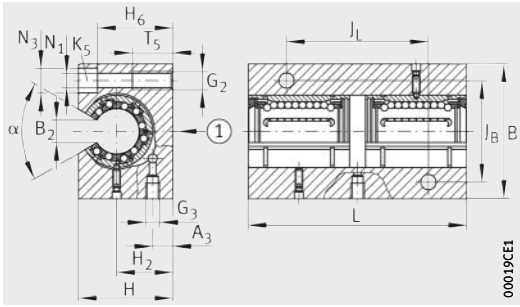
3) Dimension B₂ on diameter F_W.

4) Dimension J_L and lubrication hole symmetrical to the bearing length L.

5) Lubrication nipple. Designs and dimensions, see page 31.

6) The tolerances are valid for KTB...PP-AS.

7) ① Main load direction



KTBO...PP-AS

① 7)



H ₄	A ₃	H ₅	T ₅	H ₆	N ₁	N ₃	G ₂	G ₃	K ₈ ⁵⁾	α	Fixing screws		Basic load ratings ¹⁾	
											K ₅	DIN 6912	dyn.	stat.
													C	C ₀
												ISO 4762	N	N
25,5	10	5,4	13	28	5,3	10	M6	–	NIPA1	–	M5	–	880	770
–	6	–		25				–	M6	–	78	–	M5	980 ²⁾
20	12	6,9	13	35	5,3	10	M6	–	NIPA1	–	M5	–	1 150	1 060
–	8	–		29,5				–	M6	–	78	–	M5	1 290 ²⁾
33	13	7,4	18	37	6,4	11	M8	–	NIPA2	–	M6	–	2 550	2 450
–	9	–		35,5				–	M6	–	60	–	M6	2 600 ²⁾
40	15	8,3	22	49	8,4	15	M10	–	NIPA2	–	M8	–	4 550	4 450
–	9	–		43				–	M8×1	–	60	–	M8	4 650 ²⁾
44,5	16	9,3	26	52	10,5	18	M12	–	NIPA2	–	M10	–	5 900	5 700
–	11	–		50,5				–	M8×1	–	54	–	M10	6 000 ²⁾
56	20	12,4	34	64	13	20	M16	–	NIPA2	–	M12	–	8 800	9 700
–	14	–		66				–	M8×1	–	54	–	M12	9 200 ²⁾
60	20	11,1	34	70	13	20	M16	–	NIPA2	–	M12	–	12 600	14 100
–	14	–		77				–	M8×1	–	54	–	M12	13 200 ²⁾

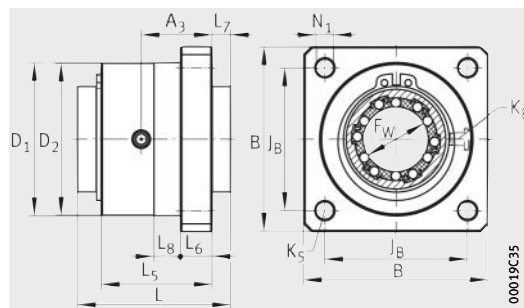
Machined range

Linear ball bearing and housing unit

With flange

Sealed

Greased, with relubrication facility



KFB..-B-PP-AS

Dimension table - Dimensions in mm

Designation	Mass m ≈g	Dimensions				Mounting dimensions			
		F _w		B	L	L ₅	L ₆	L ₇	A ₃
			Tolerances						
KFB12-B-PP-AS	80	12	$\begin{matrix} +0,008 \\ 0 \end{matrix}$	40	32	22	6	4,2	11,5
KFB16-B-PP-AS	120	16	$\begin{matrix} +0,009 \\ -0,001 \end{matrix}$	50	36	24	8	5,2	12,5
KFB20-B-PP-AS	220	20	$\begin{matrix} +0,009 \\ -0,001 \end{matrix}$	60	45	30	10	6,7	15,8
KFB25-B-PP-AS	430	25	$\begin{matrix} +0,011 \\ -0,001 \end{matrix}$	70	58	42	12	7	22
KFB30-B-PP-AS	640	30	$\begin{matrix} +0,011 \\ -0,001 \end{matrix}$	80	68	50	14	8	26
KFB40-B-PP-AS	1 280	40	$\begin{matrix} +0,013 \\ -0,002 \end{matrix}$	100	80	59	16	9,2	30,3
KFB50-B-PP-AS	2 160	50	$\begin{matrix} +0,013 \\ -0,002 \end{matrix}$	130	100	75	18	11,2	38,8

1) The basic load ratings are only valid for hardened (670 HV + 165 HV) and ground shaft raceways.

2) For fixing screws ISO 4762-8.8.

If there is a possibility of settling, the screws should be secured against rotation.

3) Lubrication nipple. Designs and dimensions, see page 31.



N ₁	K _S ²⁾	D ₁ +0,2	D ₂ g7	J _B	L ₈	K ₈ ³⁾	Ball rows	Basic load ratings ¹⁾	
							Quantity	dyn. C N	stat. C ₀ N
5,5	M5	31,5	32	30	10	NIPD3	5	540	385
5,5	M5	37,5	38	35	10	NIPD3	5	710	530
6,6	M6	45,5	46	42	10	NIPD3	6	1 570	1 230
6,6	M6	57,5	58	54	10	NIPA1	6	2 800	2 220
9	M8	65,5	66	60	10	NIPA1	6	3 600	2 850
11	M10	89,5	90	78	10	NIPA1	6	6 000	4 400
11	M10	97,5	98	98	10	NIPA2	6	8 700	6 300



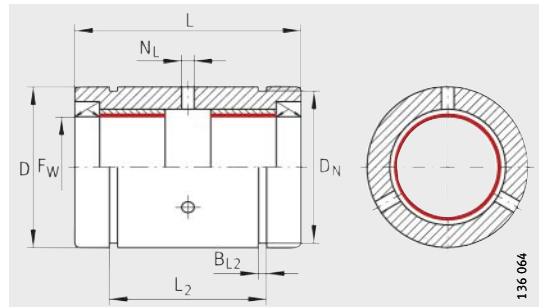
Plain bearing range

Linear plain bearings

Closed or with segment cutout

Sealed

Greased, with relubrication facility



PAB...-PP-AS, PABO...-PP-AS

Dimension table - Dimensions in mm

Designation		Mass m ≈g	Dimensions			Mounting dimensions	
			F _w	D h7 ²⁾	L h12	L ₂ ³⁾ H13	B _{L2} ⁴⁾ H13
PAB12-PP-AS	-	26	12	22	32	22,6	1,3
-	PABO12-PP-AS	21					
PAB16-PP-AS	-	34	16	26	36	24,6	1,3
-	PABO16-PP-AS	28					
PAB20-PP-AS	-	68	20	32	45	31,2	1,6
-	PABO20-PP-AS	58					
PAB25-PP-AS	-	132	25	40	58	43,7	1,85
-	PABO25-PP-AS	113					
PAB30-PP-AS	-	169	30	47	68	51,7	1,85
-	PABO30-PP-AS	143					
PAB40-PP-AS	-	426	40	62	80	60,3	2,15
-	PABO40-PP-AS	362					
PAB50-PP-AS	-	773	50	75	100	77,3	2,65
-	PABO50-PP-AS	657					

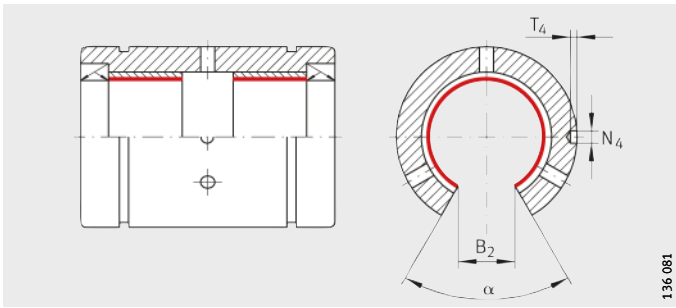
1) The basic static load ratings are not valid if the bearings above are fitted – as shown on the following pages – in housings.

2) The tolerance is only valid for PAB...-PP-AS.

3) Holes symmetrical to bearing length L.

4) Slot dimensions suitable for retaining rings to DIN 471.

5) Dimension B₂ on diameter F_w.



PABO..PP-AS
Segment cutout and fixing hole

D _N	B ₂ ⁵⁾	T ₄	N ₄	N _L H13	α °	Basic load ratings ¹⁾
						stat. C ₀ N
21	–	–	–	2,5	–	60 000
	7,6	1,2	2,2		78	
24,9	–	–	–	2,5	–	96 000
	10,1	1,2	2,2		78	
30,3	–	–	–	2,5	–	150 000
	10	1,2	2,2		60	
37,5	–	–	–	2,5	–	250 000
	12,5	1,5	3		60	
44,5	–	–	–	3	–	375 000
	13,6	1,5	3		54	
59	–	–	–	3	–	600 000
	18,2	1,5	3		54	
72	–	–	–	4	–	1 000 000
	22,7	1,5	3		54	



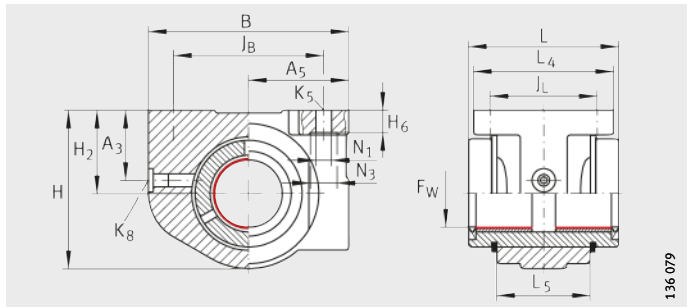
Plain bearing range

Linear plain bearing units

Closed or with segment cutout

Sealed

Greased,
with relubrication facility



PAGBA...PP-AS, PAGBAO...PP-AS

Dimension table - Dimensions in mm

Designation		Mass m ≈g	Dimensions			Mounting dimensions				
			F _W	B	L h12	H	J _B	A ₅	B ₂ ²⁾	L ₄
PAGBA12-PP-AS	-	70	12	42	32	34	32 ± 0,15	21 ± 0,01	-	32
-	PAGBAO12-PP-AS	60				30,5		21	7,6	
PAGBA16-PP-AS	-	110	16	50	36	41	40 ± 0,15	25 ± 0,01	-	35
-	PAGBAO16-PP-AS	90				36,8		25	10,1	
PAGBA20-PP-AS	-	180	20	60	45	47,5	45 ± 0,15	30 ± 0,01	-	42
-	PAGBAO20-PP-AS	160				44,5		30	10	
PAGBA25-PP-AS	-	350	25	74	58	60	60 ± 0,2	37 ± 0,01	-	54
-	PAGBAO25-PP-AS	310				56		37	12,5	
PAGBA30-PP-AS	-	480	30	84	68	67	68 ± 0,2	42 ± 0,01	-	60
-	PAGBAO30-PP-AS	430				63,5		42	13,6	
PAGBA40-PP-AS	-	1 070	40	108	80	87	86 ± 0,2	54 ± 0,015	-	78
-	PAGBAO40-PP-AS	910				82,4		54	18,2	
PAGBA50-PP-AS	-	1 650	50	130	100	98	108 ± 0,2	65 ± 0,015	-	70
-	PAGBAO50-PP-AS	1 460				92,8		65	22,7	

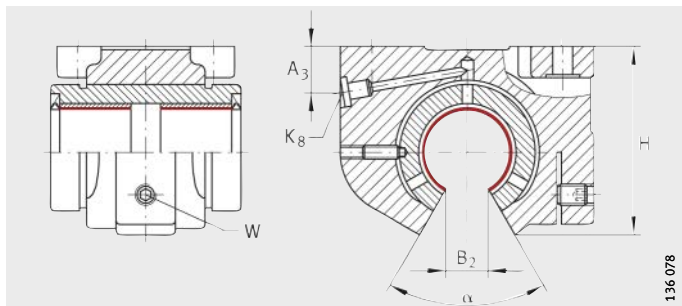
1) Designs and dimensions, see page 31.

2) Dimension B₂ on diameter F_W.

3) For fixing screws ISO 4762-8.8.

If there is a possibility of settling, the screws should be secured against rotation.

4) Note maximum tightening torques.

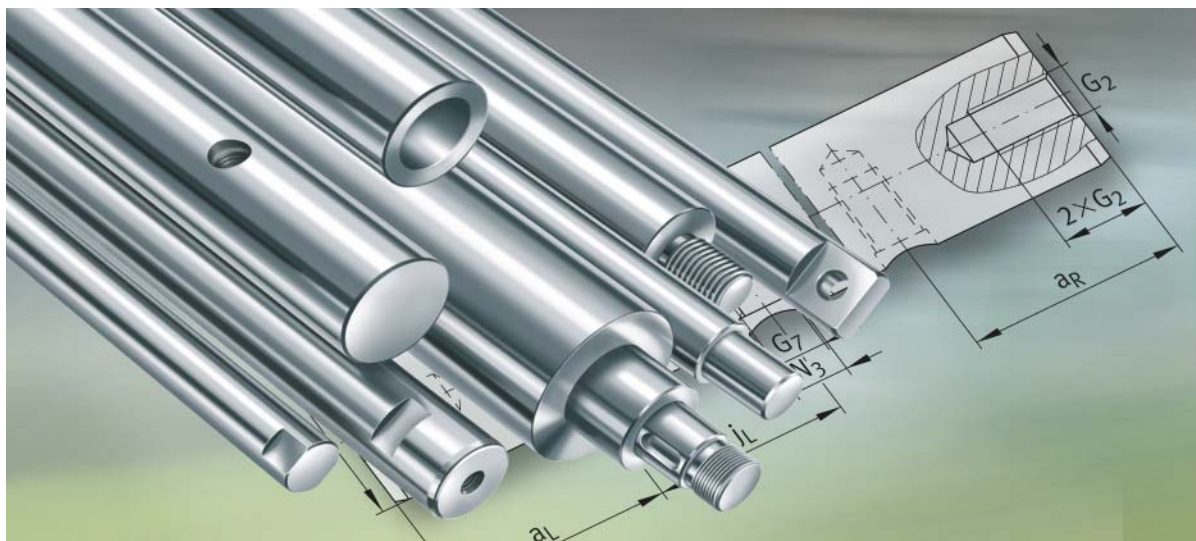


136 078

PAGBAO...PP-AS
Segment cutout

J _L	L ₅	H ₂	A ₃	H ₆	N ₁ ³⁾	N ₃ ³⁾	K ₅	Width across flats W ⁴⁾		α	K ₈	Lubrication nipple ¹⁾
									max. Nm			
23±0,15	20	18±0,01	15	4,8	4,7	8	M4	–	–	–	NIPA1	
		18	7,8					2	1	78		
26±0,15	22	22±0,01	15	5,4	4,7	8	M4	–	–	–	NIPA1	
		22	10					2,5	1,5	78		
32±0,15	28	25±0,01	21	6,7	4,7	8	M4	–	–	–	NIPA1	
		25	11					2,5	1,5	60		
40±0,2	40	30±0,01	23	7,8	5,7	10	M5	–	–	–	NIPA1	
		30	13					3	3	60		
45±0,2	48	35±0,01	25	8,7	6,8	11	M6	–	–	–	NIPA2	
		35	14					3	4	54		
58±0,2	56	45±0,01	30	11	9,2	15	M8	–	–	–	NIPA2	
		45	18					4	5	54		
50±0,2	72	50±0,015	34	12,5	9,2	15	M8	–	–	–	NIPA2	
		50	19					4	7	54		










Solid shafts
Hollow shafts

Solid shafts, hollow shafts

	Page
Matrix	Matrix for preselection of solid and hollow shafts..... 106
Product overview	Solid shafts, hollow shafts..... 108
Features	High precision raceway for economical linear guidance systems 109
	Steels, hardness, surface, tolerances, lengths 109
	Coatings..... 110
	Available materials, coatings, tolerances 112
	Solid shafts with threaded holes..... 113
	Shafts according to customer requirements 114
	Shaft machining, shaft specification 118
Accuracy	Length tolerance..... 120
	Straightness value to ISO 13012..... 120
Ordering example, ordering designation	Solid shaft, without machining 121
	Hollow shaft, without machining..... 121
	Solid shaft, with machining 121
	Solid shaft, according to customer requirements..... 122
	Shaft guidance system 123
Dimension tables	Solid shafts..... 124
	Recommended threaded holes for solid shafts..... 125
	Hollow shafts 126



Matrix for preselection of solid and hollow shafts

Solid shafts and hollow shafts		Shaft diameter d_{LW} mm from ... to	Standard tolerance for shaft
Solid shafts Without threaded holes	W 	4 – 80	h6
Solid shafts With threaded holes	W 	10 – 80	h6
Hollow shafts	WH 	12 – 80	h7
Shafts According to customer requirements	W  	10 – 80	h6, h7

Definition:

- Available by agreement
- Available

1) Not available for all diameters.

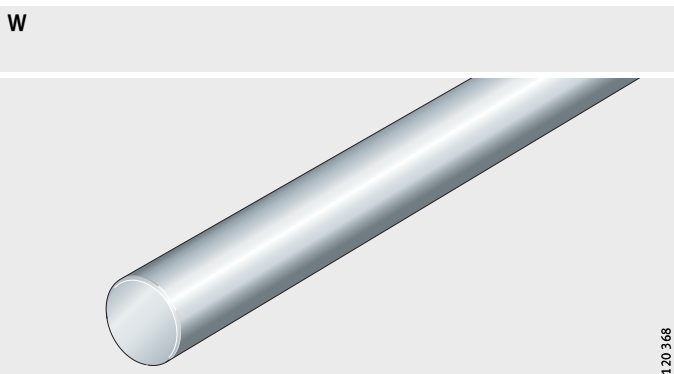
2) For WH, Cf53 or C60.

Special tolerances, only for shafts made from quenched and tempered steel		Steel			Coating ¹⁾		Description
		Quenched and tempered steel ²⁾ Cf53	Corrosion-resistant steel ¹⁾		Hard chromium	Corrotect®	
			X46Cr13	X90CrMoV18			Page
j5	f7	●	■	■	■	■	109
j5	f7	●	■	■	■	■	113
h7	–	●	–	–	■	■	109
j5	f7	●	■	■	■	■	114

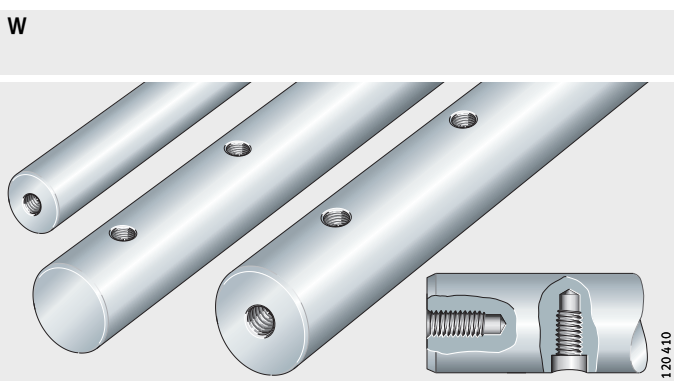


Product overview Solid shafts, hollow shafts

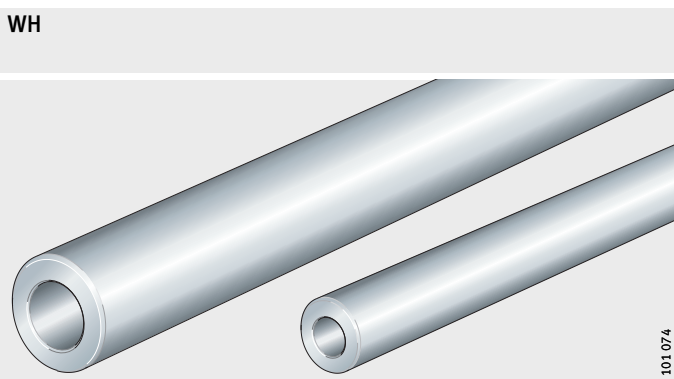
Solid shafts
Without threaded holes



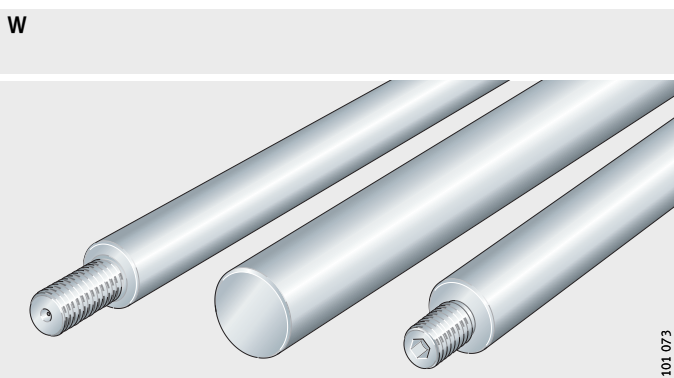
Axial and radial threaded holes



Hollow shafts



Shafts according to customer requirements



Solid shafts, hollow shafts

Features

Solid and hollow shafts are high precision shafts made from quenched and tempered steel to rolling bearing quality and are supplied in metric sizes.

Hollow shafts are particularly suitable for reduced-mass designs. For location, solid shafts can be provided with radial and axial threaded holes or can, by agreement, be produced completely in accordance with a customer drawing, see page 113 to page 117.

High precision raceway for economical linear guidance systems

The material quality of the shafts guarantees high dimensional and geometrical accuracy (roundness, parallelism). Due to their high surface hardness and surface quality, the shafts are highly suitable as precision raceways for linear ball bearings.

High precision shafts are also suitable as guide rods for plain bushes, as stretch and levelling rollers and in the construction of equipment and automatic machinery.

They can be combined with linear ball bearings, yoke type, stud type, ball bearing and profiled track rollers to give linear guidance systems that are rigid, precise, economical and ready to fit, with high load carrying capacity and a long operating life.

Steels, hardness, surface, tolerances, lengths

Shafts made from Cf53 (material number 1.1213) are induction hardened and ground; the surface hardness is 670 HV + 165 HV (59 HRC + 6 HRC).

Hollow shafts are only available made from quenched and tempered steel.

Shafts made from corrosion-resistant steel to ISO 683-17 and EN 10880

As an alternative to quenched and tempered steel, solid shafts are also available in corrosion-resistant steels, for example X46Cr13 (material number 1.4034) or X90CrMoV18 (material number 1.4112). The surface hardness in the case of X46 is 520 HV + 115 HV (52 HRC + 4 HRC). The surface hardness in the case of X90 is 580 HV + 85 HV (54 HRC + 4 HRC).

These steels are particularly suitable for use in the foodstuffs industry, medical equipment and semiconductor technology.

The suffix is X46 or X90.



Due to the hardness curve, shafts made from the materials X46Cr13 and X90CrMoV18 have only limited corrosion resistance on the end faces. This also applies to any soft-annealed areas.



Solid shafts, hollow shafts

Hardness, surface, tolerances, lengths

A uniform hardening depth will ensure a smooth transition from the hardened surface layer to the tough, normally annealed core, which can support bending stresses.

The standard surface is Ra 0,3.

Solid shafts have the normal tolerance h6, while hollow shafts have h7.

High precision shafts are available in single piece lengths up to 6 000 mm. Longer shafts are available by agreement and are assembled (with mortice and tenon joints).

Available steels and tolerances, see page 112.

Coatings

Coatings and hard chromium coating provide optimum anti-wear and anti-corrosion protection for shafts and are optional.

The characteristics of the coatings are also shown in the table Coatings, page 111.

Hard chromium coating – Anti-wear protection

Hard chromium coating is suitable for applications in which a high degree of anti-wear protection is required. The chromium coating also offers good corrosion resistance.

Chromium coated shafts are to tolerance h7.

The thickness of the chromium coating is at least 5 μm , the hardness is 800 HV to 1050 HV.

The suffix is CR.

Corrotect® – Anti-corrosion protection

Corrosion-resistant shafts are coated with the special coating Corrotect® and, for production reasons, have centring or threaded holes in the end faces.

The inside diameter of hollow shafts is not coated.

Corrotect® is resistant to neutral, organic fluids such as oil, brake fluid and petrol. For applications where aqueous salt solutions in the pH range from 5 to 10 are present, Corrotect® is also suitable due to its good resistance.

The suffix is RRF.

Corrotect® reduces the adhesion of weld spatter.

Corrotect® can be worn away by contact seals.

The coating is not permitted for direct contact with foodstuffs and is not suitable in abrasive ambient media.



For application in the food industry, the Schaeffler Group also offers the special coating Corrotect® Cr(VI)-free.

It thus complies with the requirements for RoHS in accordance with EU Directive 2002/95/EC. All other advantages are identical with the standard Corrotect® coating.

The suffix is RROC.

Coatings

Feature	Coating		
	Corrotect®		Hard chromium
	Cr(VI)-containing ¹⁾	CR(VI)-free	
Suffix	RRF	RROC	–
Colour	Black	Colourless, blue to iridescent	Chromium
Coating thickness in µm	0,5 – 5,0	0,5 – 5,0	5,0 – 15,0
Composition	Zinc alloyed with iron and cobalt	Zinc alloyed with iron	Chromium
Coating hardness in HV	300	300	800 – 1 050
Anti-corrosion protection ²⁾ in h	96	96	120
Anti-wear protection	–	–	yes
Maximum shaft length in mm	3 500	3 500	∅ 6 – 8 = 3 900 ∅ ≧ 10 = 5 900
Cr(VI)-free	no	yes	no

1) Cr(VI)-containing parts are not suitable for the food industry.

2) Salt spray test to DIN 50021.



Machined surfaces, end faces and bores may be uncoated.



Solid shafts, hollow shafts

Available materials, coatings, tolerances Solid and hollow shafts

Shaft diameter	Solid shafts					Hollow shafts
	Material					
	Quenched and tempered steel			X46Cr13	X90CrMoV18	Quenched and tempered steel
	Tolerance ³⁾	CR ¹⁾	RRF RROC ²⁾			Tolerance
mm	h6	h7	h6	h6	h6	h7
4	●	–	■	–	●	–
5	●	–	■	–	–	–
6	●	●	■	●	●	–
8	●	●	■	●	●	–
10	●	●	■	●	●	–
12	●	●	■	●	●	●
14	●	●	■	●	●	–
15	●	●	■	●	●	–
16	●	●	■	●	●	●
20	●	●	■	●	●	●
25	●	●	■	●	●	●
30	●	●	■	●	●	●
40	●	●	■	●	●	●
50	●	●	■	●	●	●
60	●	●	■	–	–	●
80	●	●	■	–	–	●

■ Available by agreement.

● Available design.

1) Hard chromium coating, see page 110.

2) Corrotect® coating, see page 110.

3) Other tolerances available by agreement.

Solid shafts with threaded holes






Where shafts are to be supported or connected to other elements, fixing holes are required.

The standard threaded holes for solid shafts are defined as hole patterns B01 to B05 in accordance with the table.

In addition, holes may be made in accordance with a customer drawing with or without threads, *Figure 1*, page 114 to *Figure 13*, page 117.

Ordering examples, see page 121.

Codes for hole patterns

Code		Design of holes
B01		Axial threaded hole on one side
B02		Axial threaded holes on both sides
B03		Radial threaded holes
B04		Radial threaded holes and axial threaded hole on one side
B05		Radial threaded holes and axial threaded holes on both sides

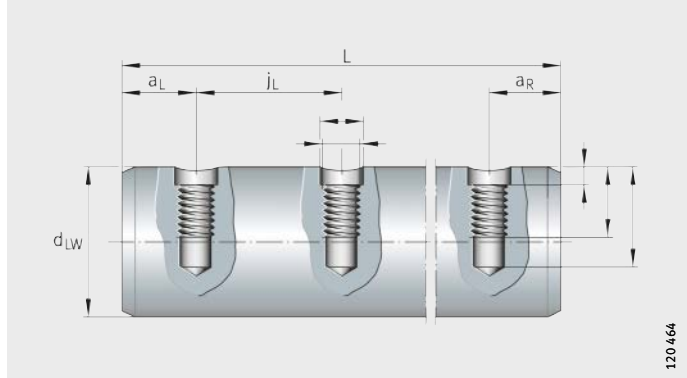


Solid shafts, hollow shafts

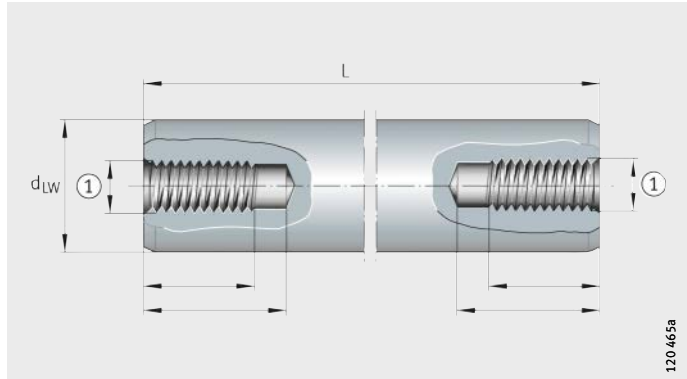
Shafts according to customer requirements

In order to place enquiries for special shafts, please use your own drawing or copy our templates and complete using the required values, *Figure 1 to Figure 13*, page 117.

Figure 1
Radial holes
with and without threads

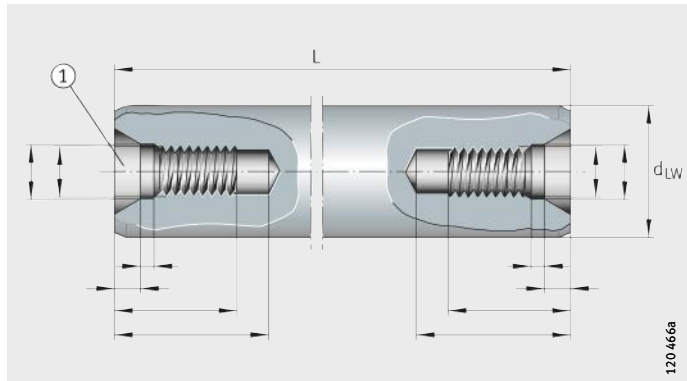


① Diameter to
DIN 336 or DIN 13
Figure 2
Internal threaded hole,
on one or both sides



① For threaded hole with centring hole
DIN 332-D recommended

Figure 3
Internal threaded hole
with centring hole



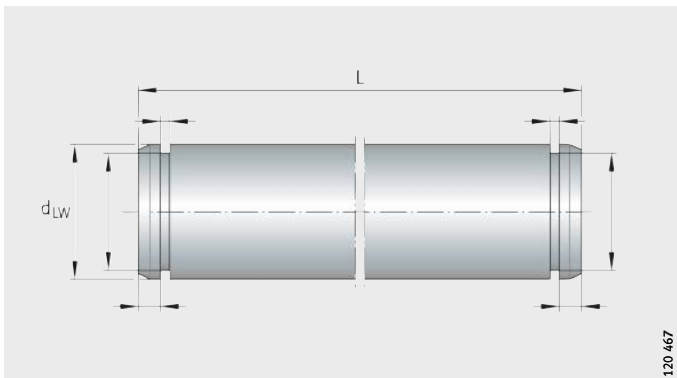


Figure 4
Undercut for retaining ring

120 467

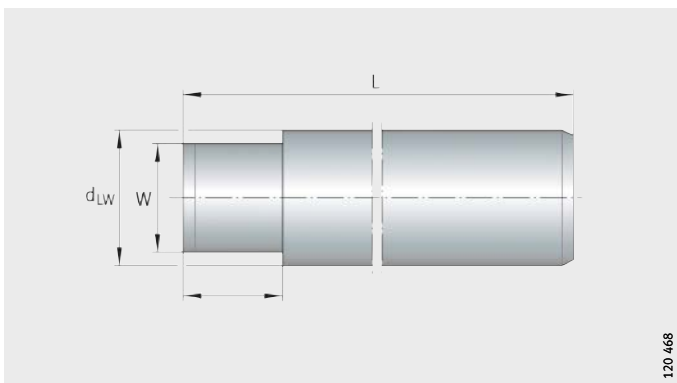
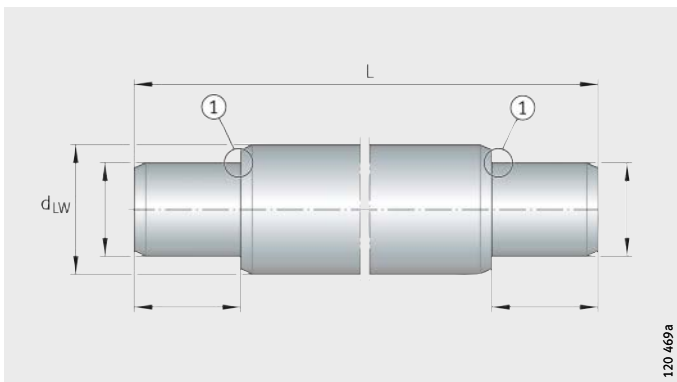


Figure 5
Width across flats W

120 468



① Undercut type F DIN 509 (both sides)

Figure 6
Journal

120 469a

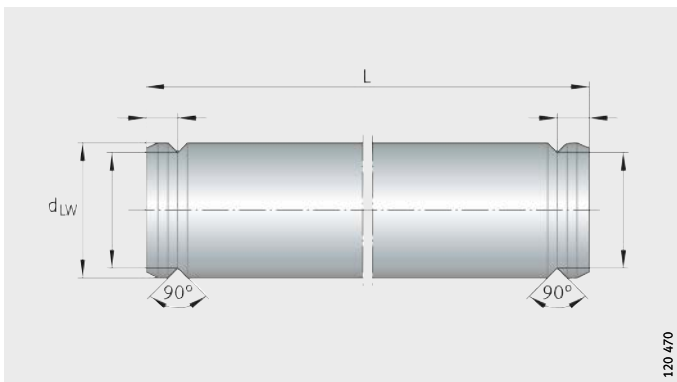


Figure 7
90° undercut

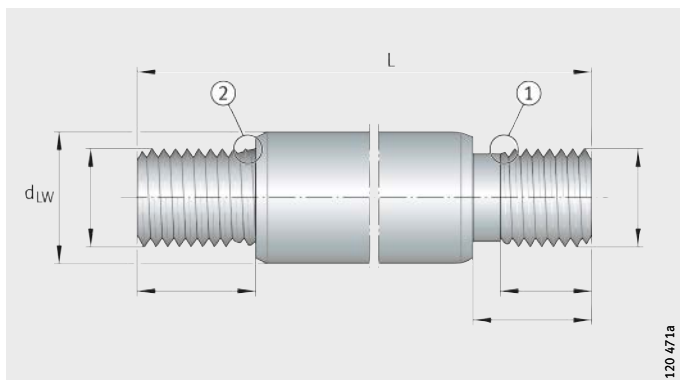
120 470



Solid shafts, hollow shafts

- ① Thread runout to DIN 76-1A, with undercut to DIN 76-A
- ② With undercut, DIN 76-A recommended

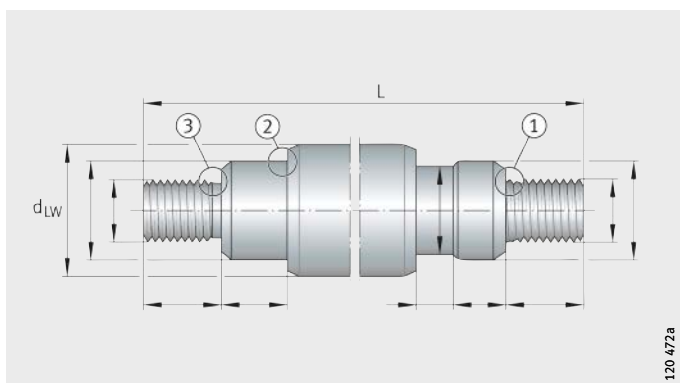
Figure 8
Threaded journal



120 471a

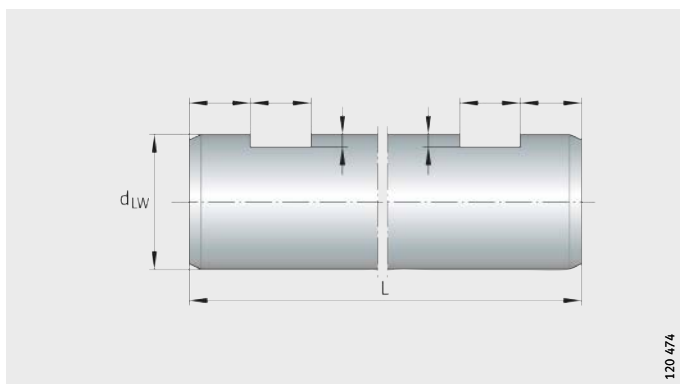
- ① With undercut, DIN 76-A recommended
- ② With undercut type F, DIN 509 recommended
- ③ Thread runout to DIN 76-1A

Figure 9
Journal and threaded journal



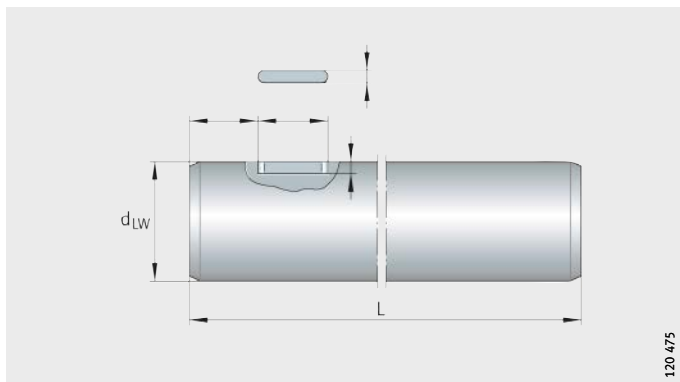
120 472a

Figure 10
Slot



120 474

Figure 11
Keyway



120 475

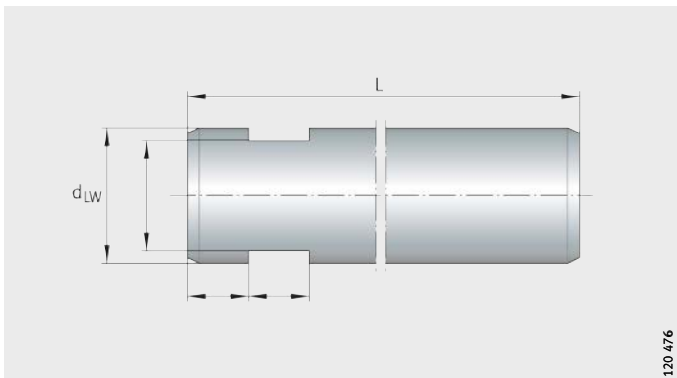


Figure 12
Width across flats

120 476

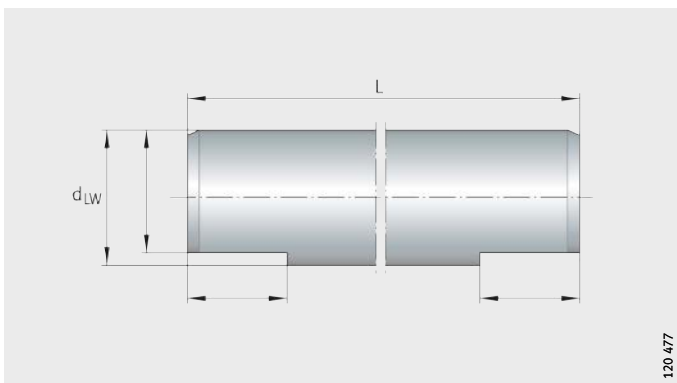


Figure 13
Flattened area

120 477



Solid shafts, hollow shafts

Shaft machining, shaft specification Soft annealed shafts

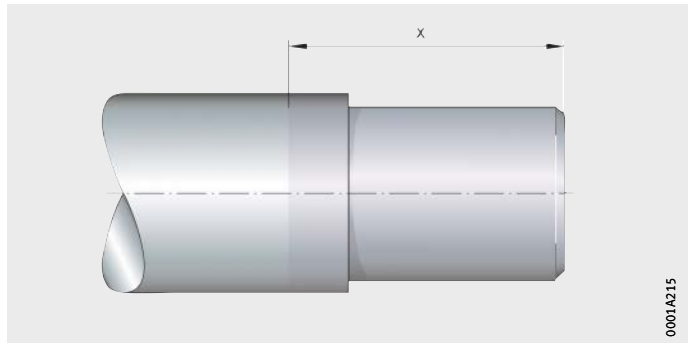
Additional machining (such as journals, flattened areas, external threads) may require soft annealing of the corresponding areas. In this case, slight changes may occur in the dimensional and geometrical tolerances as well as the surface quality of the soft annealed area, *Figure 14*. Material discoloration may occur in the annealed area and there may be residual hardness in the transitional zone.



In the case of corrosion-resistant steels, the X class materials, the anti-corrosion protection is restricted here.

x = soft annealed area

Figure 14
Soft annealed shaft



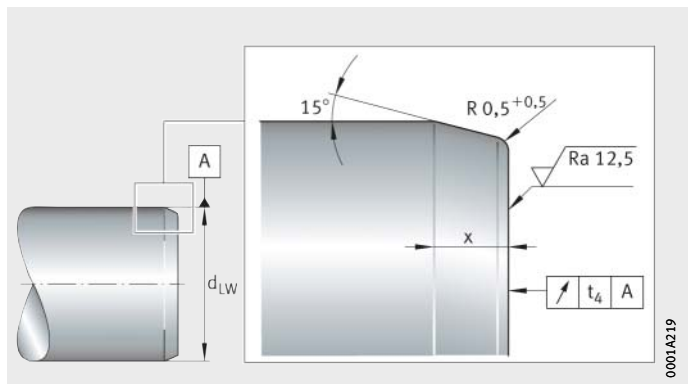
Standard chamfer

After cutting to length, both ends of the shaft are chamfered, *Figure 15* and table. However, they can also be supplied without chamfers as a parting cut, *Figure 16*, page 119.

Chamfer, as a function of shaft diameter

Shaft diameter d_{LW} mm	Chamfer x mm	Axial runout t_4 mm
$d_{LW} \leq 8$	$0,5 \times 45^\circ$	0,2
$8 < d_{LW} \leq 10$	1^{+1}	0,2
$10 < d_{LW} \leq 30$	$1,5^{+1}$	0,3
$30 < d_{LW} \leq 80$	$2,5^{+1}$	0,5

Figure 15
Standard chamfer



Parting cut In the case of a parting cut, the shaft is only cut to length, *Figure 16*. There is no additional machining of the end faces. A burr may be present. The suffix is T.

t_4 = axial runout tolerance, table, page 118

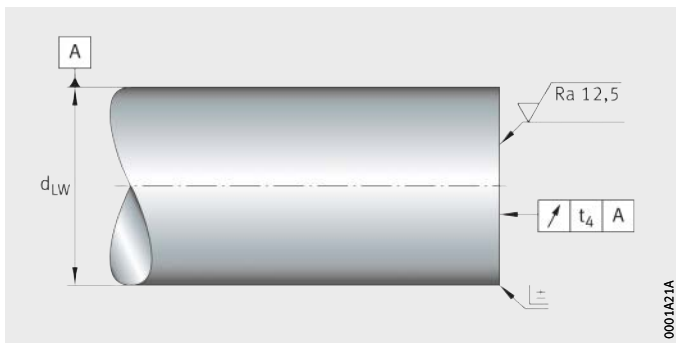


Figure 16
Parting cut

Straightness The standard straightness is shown in *Figure 17*.

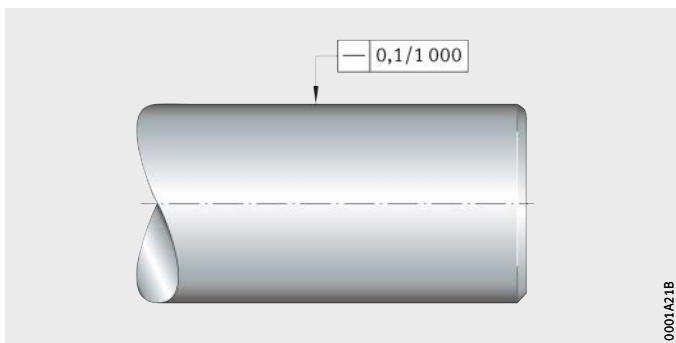


Figure 17
Straightness

Shafts with mortice and tenon joint If the shaft length is in excess of the stock length, the shafts are joined together.

The individual sections of shafts are joined by means of mortice and tenon joints, *Figure 18*. The joints are marked accordingly. Shafts screwed together are available by agreement.

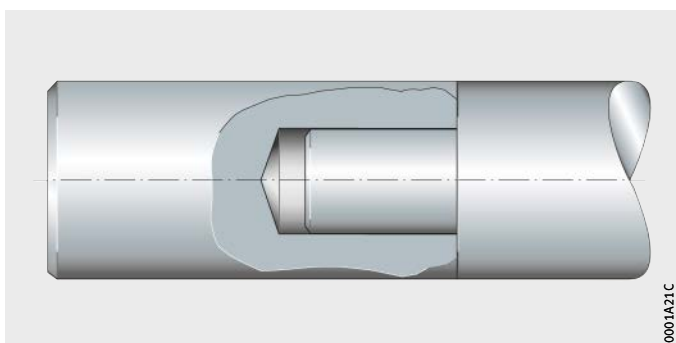


Figure 18
Shaft with mortice and tenon joint



Solid shafts, hollow shafts

Accuracy Length tolerance

Length tolerances are dependent on the shaft length, see table and Figure 19.

Special tolerances are available by agreement.

Tolerance

Shaft length L mm		Tolerance mm
over	incl.	max.
–	400	±0,5
400	1 000	±0,8
1 000	2 000	±1,2
2 000	4 000	±2
4 000	6 000	±3

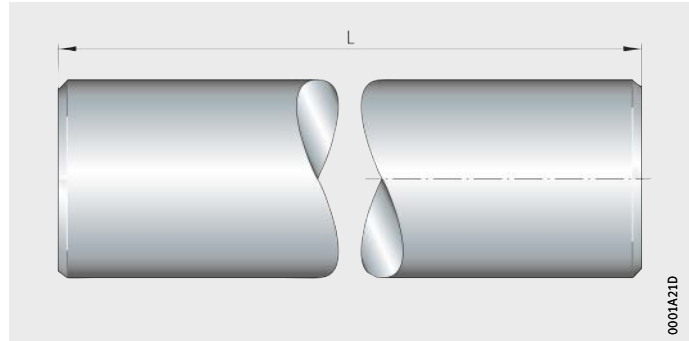


Figure 19
Length tolerance

Straightness value to ISO 13012

The measurement points are separated by a distance of 1 000 mm. Shafts < 1 000 mm have a maximum of two measurement points, Figure 20.

The straightness tolerance is half of the dial gauge value with a shaft revolution of 360°.

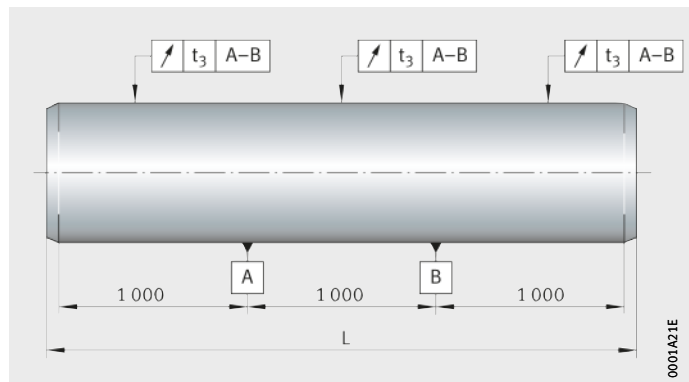


Figure 20
Straightness measurement

**Ordering example,
ordering designation**

Solid shaft, without machining	Type	W
	Shaft diameter d_{LW}	20
	Tolerance	h6
	Material	Cf53
	Coating	–
	Length	1 200
	Parting cut	–
	Standard chamfer	No suffix
Ordering designation	W20/h6-Cf53-1 200	
Hollow shaft, without machining	Type	WH
	Shaft diameter d_{LW}	20
	Tolerance	h7
	Material	C60
	Coating	–
	Length	1 500
	Parting cut	T
	Standard chamfer	–
Ordering designation	WH20/h7-C60-1 500-T	
Solid shaft, with machining	Type	W
	Shaft diameter d_{LW}	30
	Tolerance	h7
	Material	Cf53
	Coating	Cr
	Hole pattern	B05
	Axial threaded hole	M12
	Radial threaded hole	M10
	Hole pitch, radial threaded hole	100
	Length	1 110
	Parting cut	T
	Standard chamfer	–
	Distance a_L	60
Distance a_R	50	
Ordering designation	W30/h7-Cf53-Cr-B05/M12-M10×100-1110-T-60-50	



Solid shafts, hollow shafts

Solid shaft, according to customer requirements

If the standard designations are not sufficient to describe the shaft, please submit a drawing with your enquiry.

Possible ordering designation for standard shafts

Type	W, WH
Shaft diameter d_{LW}	10 to 80
Tolerance ¹⁾	h6, h7
Material ²⁾	Cf53, X46, X90
Coating	Cr, RROC
Hole pattern	B01, B02, B03, B04, B05
Axial threaded hole ³⁾	M3 to M24
Radial threaded hole ³⁾	M4 to M14
Hole pitch, radial threaded hole j_L	Measured from centre point of hole, <i>Figure 21</i>
Length ³⁾	Single piece up to 6 000
Parting cut	T
Standard chamfer	No suffix
Distance a_L	Start of shaft – first hole, <i>Figure 21</i>
Distance a_R	Last hole – end of shaft, <i>Figure 21</i>

1) Available tolerances are dependent on diameter, see dimension table page 124 and page 126.

2) Hollow shafts are only available in Cf53 and C60.

3) Dependent on diameter, see dimension table page 124 to page 126.

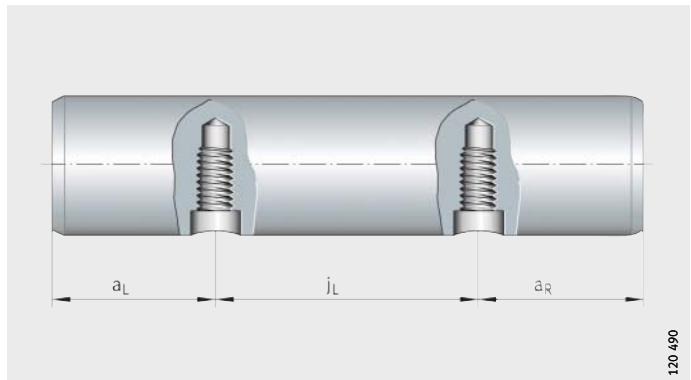


Figure 21
Hole pitch of radial threaded hole j_L

Shaft guidance system

Elements of shaft guidance systems (linear ball bearings, solid and hollow shafts) must be ordered separately.

The ordering designation of an element comprises the designation and additional specific data – where necessary, see ordering designation for shaft with axial threaded hole, linear ball bearing and *Figure 22*.

The designations are given in the dimension tables. The unit is described in greater detail by means of the additional data.

Required A shaft guidance system in a corrosion-resistant design with two sealed and corrosion-resistant linear ball bearings.

Shaft with axial threaded holes	Corrosion-resistant shaft	W20/h6-X90
	Code for hole pattern	B02
	Axial threaded hole	M8
	Shaft length	3 500
Ordering designation	1×W20/h6-X90-B02/M8-3500	
Linear ball bearing	Linear ball bearing	KB
	Size code	20
	Contact seals on both end faces	PP
	Corrotect® coating	RR
	Relubrication facility	AS
Ordering designation	2×KB20-PP-RR-AS	

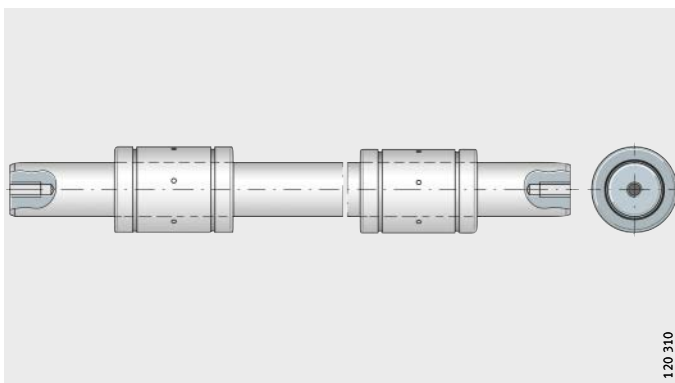
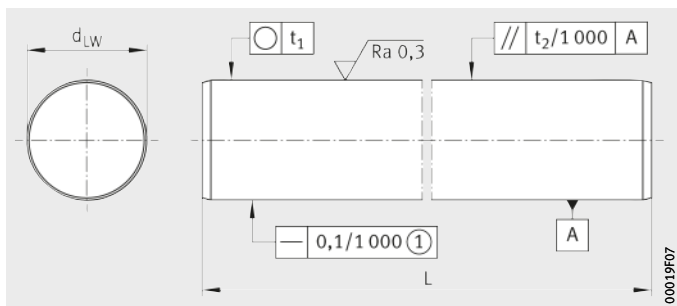


Figure 22
Shaft with axial threaded holes,
two linear ball bearings



Solid shafts



W
①³⁾

Dimension table - Dimensions in mm

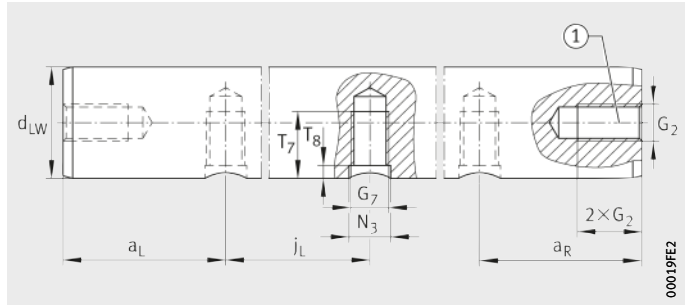
Designation	Mass m ≈kg/m	Dimensions		Tolerance h6 μm	Roundness t ₁ μm	Parallelism t ₂ ¹⁾ μm	Surface hardening depth SHD ²⁾ min.
		d _{LW}	L				
W04	0,1	4	2 500	$\begin{matrix} 0 \\ -8 \end{matrix}$	4	5	0,4
W05	0,15	5	4 000	$\begin{matrix} 0 \\ -8 \end{matrix}$	4	5	0,4
W06	0,22	6	4 000	$\begin{matrix} 0 \\ -8 \end{matrix}$	4	5	0,4
W08	0,39	8	4 000	$\begin{matrix} 0 \\ -9 \end{matrix}$	4	6	0,4
W10	0,62	10	6 000	$\begin{matrix} 0 \\ -9 \end{matrix}$	4	6	0,4
W12	0,89	12	6 000	$\begin{matrix} 0 \\ -11 \end{matrix}$	5	8	0,6
W14	1,21	14	6 000	$\begin{matrix} 0 \\ -11 \end{matrix}$	5	8	0,6
W15	1,39	15	6 000	$\begin{matrix} 0 \\ -11 \end{matrix}$	5	8	0,6
W16	1,58	16	6 000	$\begin{matrix} 0 \\ -11 \end{matrix}$	5	8	0,6
W20	2,47	20	6 000	$\begin{matrix} 0 \\ -13 \end{matrix}$	6	9	0,9
W25	3,85	25	6 000	$\begin{matrix} 0 \\ -13 \end{matrix}$	6	9	0,9
W30	5,55	30	6 000	$\begin{matrix} 0 \\ -13 \end{matrix}$	6	9	0,9
W40	9,87	40	6 000	$\begin{matrix} 0 \\ -16 \end{matrix}$	7	11	1,5
W50	15,41	50	6 000	$\begin{matrix} 0 \\ -16 \end{matrix}$	7	11	1,5
W60	22,2	60	6 000	$\begin{matrix} 0 \\ -19 \end{matrix}$	8	13	2,2
W80	39,45	80	6 000	$\begin{matrix} 0 \\ -19 \end{matrix}$	8	13	2,2

1) Differential diameter measurement.

2) To DIN ISO 13012.

3) ① For shaft length < 400 mm, max. straightness tolerance of 0,04 mm.

Recommended threaded holes for solid shafts



Axial and radial threaded holes
① ②

Dimension table · Dimensions in mm

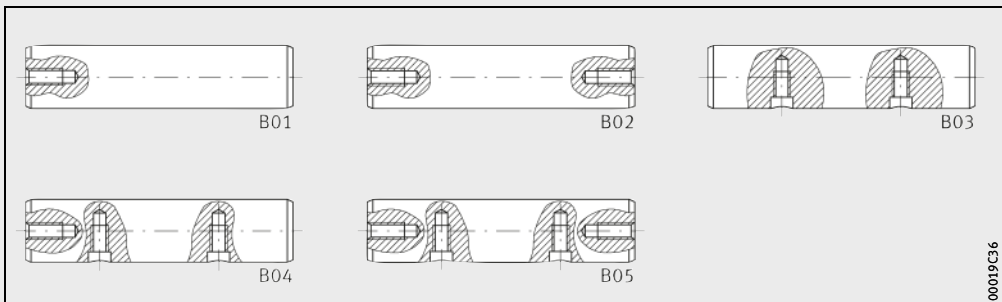
Designation d_{LW}	Axial threaded hole										Radial threaded hole								
	G_2										j_L	$a_{L \min}^{1)}$ Hole pattern B03	$a_{R \min}^{1)}$ Hole pattern B04–B05	T_7	T_8	N_3	G_7		
W08	M3	–	–	–	–	–	–	–	–	–	–	–	–	–	–	–	–		
W10	M3	M4	–	–	–	–	–	–	–	–	–	–	–	–	–	–	–		
W12	–	M4	M5	–	–	–	–	–	–	75	–	120	10	–	7	2	5	M4	
W14	–	M4	M5	M6	–	–	–	–	–	–	–	–	–	–	–	–	–	–	
W15	–	–	M5	M6	M8	–	–	–	–	–	–	–	–	–	–	–	–	–	
W16	–	–	M5	M6	M8	–	–	–	–	75	100	150	15	–	9	2,5	6	M5	
W20	–	–	–	–	–	–	–	–	–	–	–	150	15	–	9	2,5	6	M5	
W20	–	–	–	M6	M8	M10	–	–	–	75	100	150	15	–	11	3	7	M6	
W25	–	–	–	–	–	–	–	–	–	–	–	150	15	–	11	3	7	M6	
W25	–	–	–	–	M8	M10	M12	–	–	75	120	200	15	$3 \cdot G_2 + G_7$	15	3	9	M8	
W30	–	–	–	–	–	–	–	–	–	–	–	150	15	–	11	3	7	M6	
W30	–	–	–	–	–	M10	M12	M16	–	100	150	200	20	–	17	3,5	11	M10	
W40	–	–	–	–	–	M10	M12	M16	–	150	200	300	20	–	19	4	11	M10	
W40	–	–	–	–	–	M10	M12	M16	–	100	–	–	20	–	21	4	13	M12	
W40	–	–	–	–	–	–	–	–	–	–	–	150	20	–	19	4	11	M10	
W50	–	–	–	–	–	–	M12	M16	M20	–	–	200	300	20	–	21	4	13	M12
W50	–	–	–	–	–	–	M12	M16	M20	–	100	–	–	20	–	25	4	15	M14
W60	–	–	–	–	–	–	–	M16	M20	M24	–	–	–	–	–	–	–	–	–
W80	–	–	–	–	–	–	–	M16	M20	M24	–	–	–	–	–	–	–	–	–

1) a_L, a_R are dependent on the length of the shaft.

Calculation, see page 134.

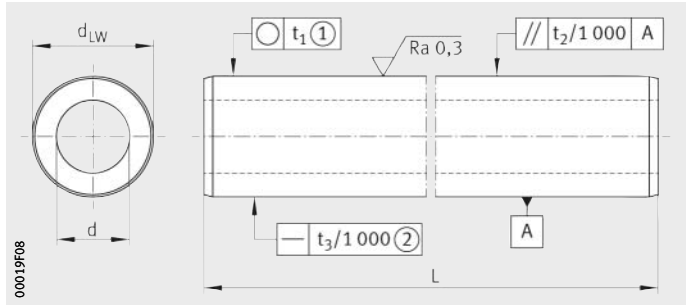
In the case of variants in accordance with codes B04 and B05, the axial threaded holes must be taken into consideration.

2) ① Depending on the hole diameter, the shaft diameter may be larger in the region of the axial hole, as a result of which there may be a deviation from the tolerances.



Codes B01 to B05 for hole patterns

Hollow shafts



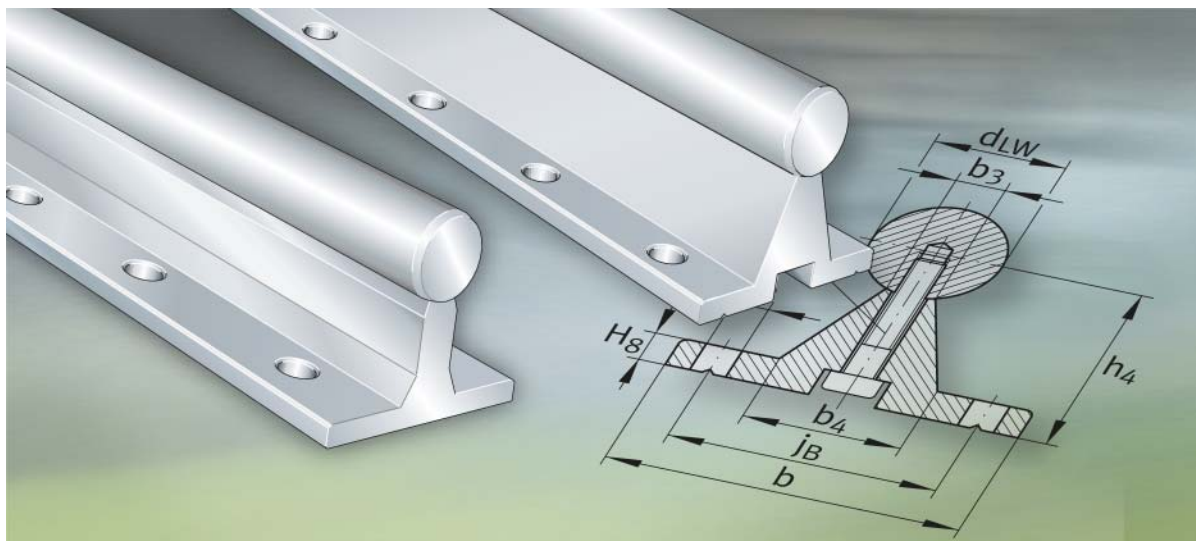
WH
①, ② 4)

Dimension table - Dimensions in mm

Designation	Mass m ≈kg/m	Dimensions		Inside diameter d ¹⁾	Tolerance d _{LW} h7 ³⁾ μm	Parallelism t ₂ μm	Straightness tolerance t ₃ μm	Surface hardening depth SHD ²⁾ min.
		d _{LW}	L max.					
WH12	0,79	12	5 700	4 ±0,45	⁰ ₋₁₈	7	0,3	0,8
WH16	1,26	16	5 700	7 ±0,15	⁰ ₋₁₈	7	0,3	0,8
WH20	1,28	20	6 000	14 ±0,15	⁰ ₋₂₁	9	0,2	1,2
WH25	2,4	25	7 100	15,4±0,15	⁰ ₋₂₁	9	0,2	1,2
WH30	3,55	30	7 100	18 ±0,15	⁰ ₋₂₁	9	0,2	1,5
WH40	5,7	40	7 100	26 ±0,15	⁰ ₋₂₅	11	0,1	1,5
WH50	10,58	50	6 500	28 ±0,25	⁰ ₋₂₅	11	0,1	1,5
WH60	14,2	60	7 300	36 ±0,3	⁰ ₋₃₀	13	0,1	1,5
WH80	20,8	80	7 300	57,4±0,35	⁰ ₋₃₀	13	0,1	2,2

- 1) Difference in the wall thickness relative to the original material ±5%.
- 2) To DIN ISO 13012.
- 3) Diameter tolerance h6 available by agreement.
- 4) ① The roundness corresponds to no more than half the diameter tolerance.
② For shaft length < 500 mm, max. straightness tolerance of 0,1 mm.





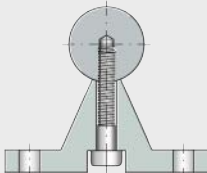
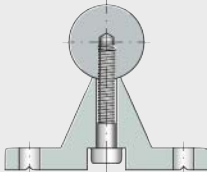
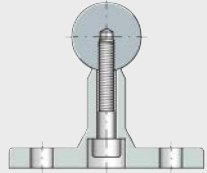
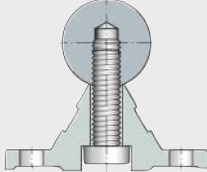
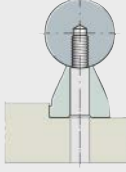
Shaft and support rail units

Shaft and support rail units

	Page
Matrix	Matrix for preselection of shaft and support rail units 130
Product overview	Shaft and support rail units 132
Features	Multi-piece raceway shafts and shaft and support rail units 133
Design and safety guidelines	Hole patterns for shaft and support rail units 134
Accuracy	Length tolerances for shafts and shaft and support rail units 136
Ordering example, ordering designation	Shaft and support rail unit 136 Possible ordering designation for standard shaft and support rail units 136
Dimension tables	Shaft and support rail units 138



Matrix for preselection of shaft and support rail units

Shaft and support rail units	Precision
<p>TSNW</p> 	+++
<p>TSWW</p> 	+++
<p>TSWWA</p> 	+++
<p>TSNW..-G4 TSNW..-G5</p> 	++
<p>TSUW</p> 	+++

Definition:
 +++ Very good
 ++ Good
 ● Available

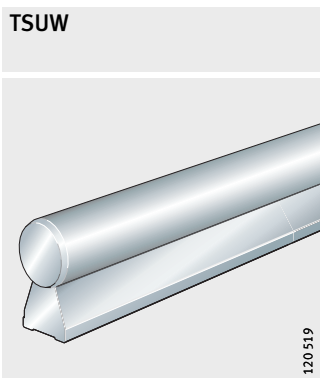
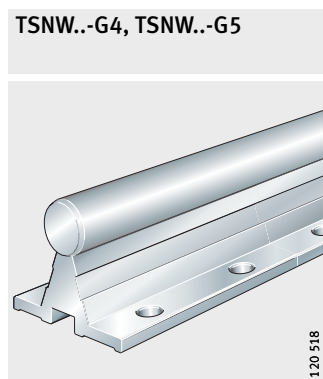
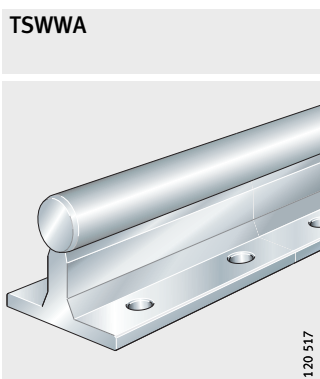
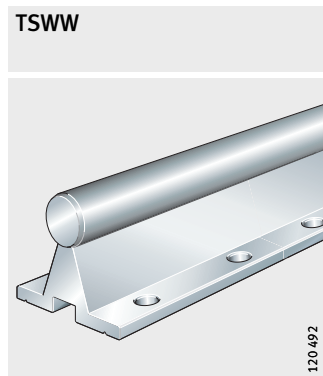
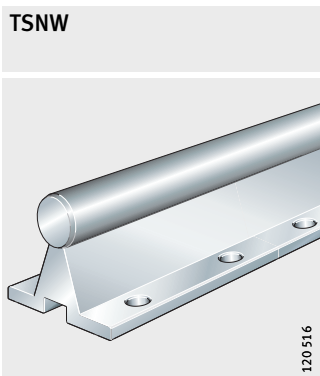
¹⁾ Location by screw mounting from below; threaded hole in the shaft.

Shaft diameter d_{LW} in mm							Features	Location		Description
								Thread	Through hole	
12	16	20	25	30	40	50				Page
●	●	●	●	●	●	●	<ul style="list-style-type: none"> <input type="checkbox"/> For location from above 	–	yes	133
●	●	●	●	●	●	●	<ul style="list-style-type: none"> <input type="checkbox"/> For location from above <input type="checkbox"/> High position of shaft 	–	yes	133
●	●	●	●	●	–	–	<ul style="list-style-type: none"> <input type="checkbox"/> For location from above <input type="checkbox"/> Narrow crosspiece 	–	yes	133
●	●	●	●	●	●	–	<ul style="list-style-type: none"> <input type="checkbox"/> For location from above <input type="checkbox"/> Accuracy class (G4, G5) dependent on shaft diameter <input type="checkbox"/> Economical 	–	yes	133
●	●	●	●	●	●	●	<ul style="list-style-type: none"> <input type="checkbox"/> Threaded holes from below 	¹⁾	–	133



Product overview Shaft and support rail units

Shaft and support rail units



Shaft and support rail units

Features Shaft and support rail units TS..W are composite units comprising a raceway shaft screw mounted to an aluminium support rail. The shaft protrudes approx. 2 mm to 3 mm beyond the end of the support rail at both ends.

The raceway shaft is made from quenched and tempered steel, see page 109. Corrosion-resistant design available by agreement.

Shaft and support rail units are composed of several individual sections depending on their length.

Shafts made from special materials such as those with coatings are available by agreement.

Multi-piece raceway shafts and shaft and support rail units

If the guidance systems are of such a length that shaft and support rail units TS..W cannot be achieved using single-piece shafts, shafts and support rails are supplied as multi-piece units, *Figure 1*. The joint locations on the shaft sections have mortice and tenon joints and are polished.

The joint locations on the shafts and support rails are offset from each other.

The maximum length of single-piece shaft and support rail units is 6 000 mm.

- ① Shaft
- ② Support rail 1
- ③ Support rail 2

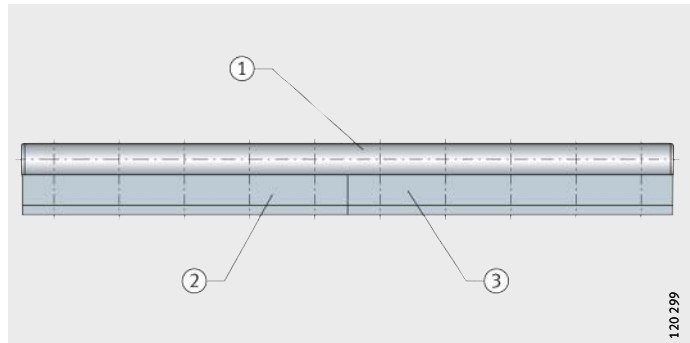


Figure 1
Shaft and support rail unit
with multiple support rail sections



Shaft and support rail units

Design and safety guidelines

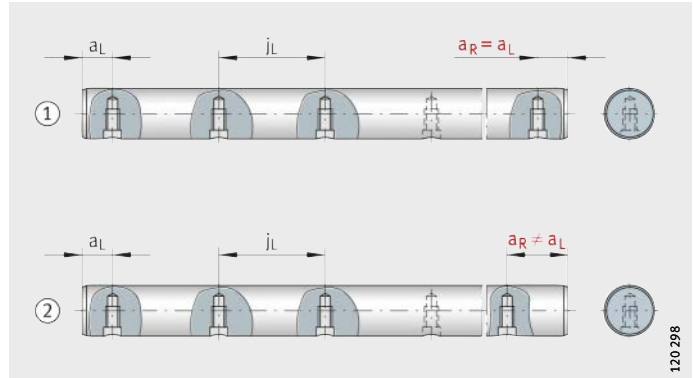
Hole patterns for shaft and support rail units

Unless stated otherwise, raceway shafts and shaft and support rail units are supplied with a symmetrical hole pattern, *Figure 2* to *Figure 4*.

An asymmetrical hole pattern may be available at customer request. In this case, $a_{L\ max} \geq a_L \geq a_{L\ min}$ and $a_{R\ max} \geq a_R \geq a_{R\ min}$.

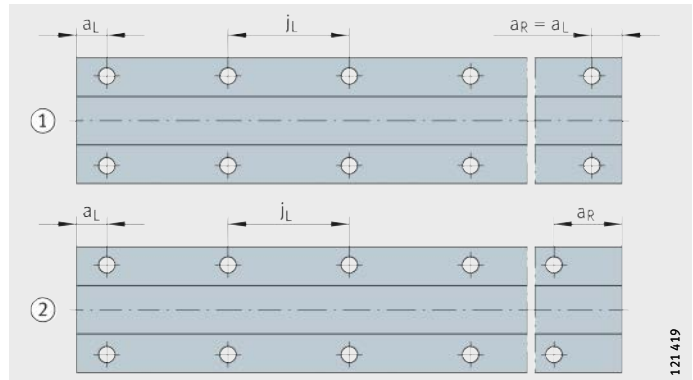
- ① Symmetrical hole pattern
- ② Asymmetrical hole pattern

Figure 2
Hole patterns for shafts with one row of holes



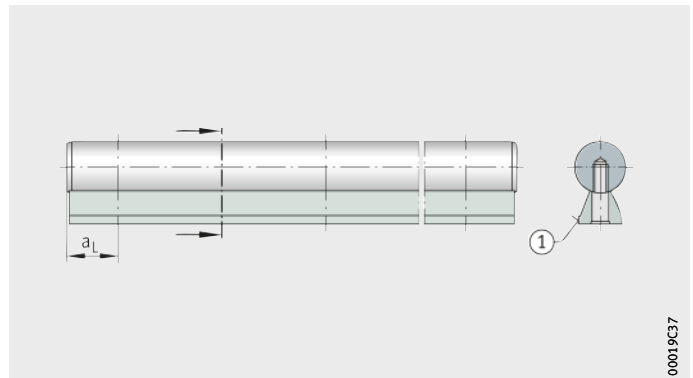
- ① Symmetrical hole pattern
- ② Asymmetrical hole pattern

Figure 3
Hole patterns for support rails with two rows of holes



- ① Support rail

Figure 4
Hole patterns for shaft and support rail unit TSUW



Maximum number of pitches between holes

The number of pitches between holes is the rounded whole number equivalent to:

$$n = \frac{l - 2 \cdot a_{L \min}}{j_L}$$

The distances a_L and a_R are generally determined by:

$$a_L + a_R = l - n \cdot j_L$$

For raceway shafts and shaft and support rail units with a symmetrical hole pattern:

$$a_L = a_R = \frac{1}{2} \cdot (l - n \cdot j_L)$$

Number of holes:

$$x = n + 1$$

- n mm
Maximum possible number of pitches or recommended distance between screws on shaft and support rail units with T-slots
- l mm
Length of shaft and support rail unit
- a_L, a_R mm
Distance between start or end of shaft and support rail unit and nearest hole
- $a_{L \min}, a_{R \min}$ mm
Minimum values for a_L, a_R according to dimension tables
- $a_{L \max}, a_{R \max}$ mm
Maximum values for a_L, a_R according to dimension tables
- j_L mm
Distance between holes
- x mm
Number of holes on shaft and support rail units with T-slots: number of screws.



If the minimum and maximum values for a_L and a_R are not observed, the counterbores of the holes may be intersected. The position a_L for shaft and support rail unit TSUW is shown in *Figure 4*, page 134.



Shaft and support rail units

Accuracy Length tolerances for shafts and shaft and support rail units

The length tolerances are shown in the table.

Tolerances

Length of shaft or shaft and support rail unit L mm	Length tolerance mm
Single-piece and multi-piece raceway shaft and support rail units	$\pm 0,1\%$ of total length
$L \leq 400$	$\pm 0,5$
$400 < L \leq 1\,000$	$\pm 0,8$
$1\,000 < L \leq 2\,000$	$\pm 1,2$
$2\,000 < L \leq 4\,000$	± 2
$4\,000 < L \leq 6\,000$	± 3

Ordering example, ordering designation

Shaft and support rail unit

Type	TSNW
Shaft diameter d_{LW}	25
Length	1 253
Distance a_L	26
Distance a_R	27
Corrosion-resistant design	Available by agreement

Ordering designation

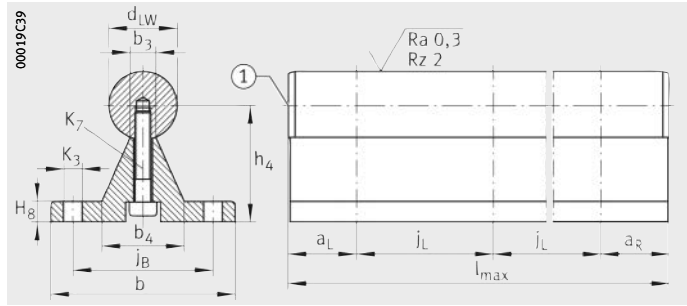
TSNW25-1253-26-27

Possible ordering designation for standard shaft and support rail units

Type	TSWW, TSNW, TSUW, TSWWA
Shaft diameter d_{LW}	12 to 50
Length	1 200
Distance a_L	Start of shaft – first hole
Distance a_R	Last hole – end of shaft
Corrosion-resistant design	Available by agreement



Shaft and support rail units



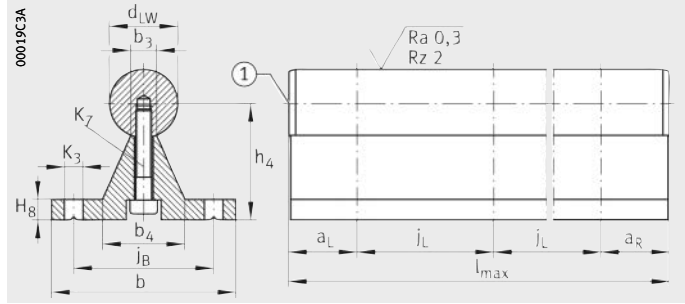
TSNW
①⁵⁾

Dimension table - Dimensions in mm

Designation	Mass m ≈g/m	Dimensions				Mounting dimensions									
		d _{LW} h ₆	b	h ₄ ¹⁾ ±0,02	l _{max} ²⁾ ±3	b ₃	b ₄	j _B	j _L	a _L /a _R ³⁾		H ₈	K ₃ ⁴⁾	K ₇ ISO 4762	
										min.	max.				
TSNW12	1 670	12	40	22	6 000	5	17	29	75	20	69	5	4,5	M4×18	
TSNW16	2 950	16	45	26	6 000	6,8	22,4	33	100	20	93	5	5,5	M5×22	
TSNW20	3 950	20	52	32	6 000	7,5	26,3	37	100	20	92	6	6,6	M6×25	
TSNW25	5 600	25	57	36	6 000	9,8	30	42	120	20	110	6	6,6	M8×30	
TSNW30	7 880	30	69	42	6 000	11	33,4	51	150	20	139	7	9	M10×35	
TSNW40	12 830	40	73	50	6 000	14,5	39,4	55	200	20	189	8	9	M10×35	
TSNW50	19 380	50	84	60	6 000	18,5	45,2	63	200	20	188	9	11	M12×40	

- 1) In relation to the nominal shaft diameter, measured whilst clamped.
- 2) Maximum length of single-piece shaft and support rail units; longer shaft and support rail units, see page 133. Depending on the length of the shaft and support rail unit, the support rail is composed of several individual sections.
- 3) Dimensions a_L/a_R are dependent on the length of the shaft and support rail unit. Calculation, see page 135.
- 4) For fixing screws DIN 7984. If there is a possibility of settling, the screws should be secured against rotation.
- 5) ① The shaft may if necessary protrude on both sides beyond the support rail by approx. 3 mm.

Shaft and support rail units



TSWW
① 5)

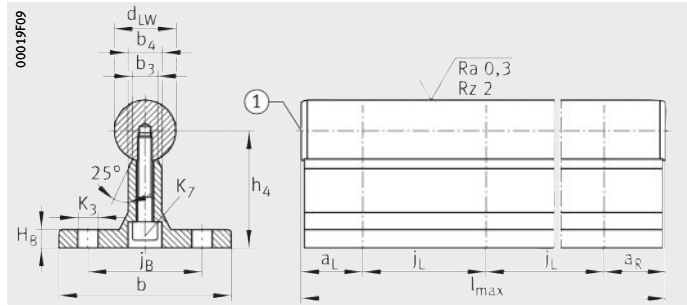
Dimension table · Dimensions in mm

Designation	Mass m ≈g/m	Dimensions				Mounting dimensions								
		d _{LW} h6	b	h ₄ ¹⁾ ±0,02	l _{max} ²⁾ ±3	b ₃	b ₄	j _B	j _L	a _L /a _R ³⁾		H ₈	K ₃ ⁴⁾	K ₇ ISO 4762
										min.	max.			
TSWW12	1 670	12	40	22	6 000	5	17	29	120	20	114	5	4,5	M4×18
TSWW16	3 150	16	54	32	6 000	6,8	24,7	41	150	20	143	6	5,5	M5×25
TSWW20	4 030	20	54	34,02	6 000	7,8	24,7	41	150	20	143	6	5,5	M5×25
TSWW25	5 900	25	65	39,66	6 000	9,3	30,3	51	150	20	142	6	6,6	M6×30
TSWW30	7 580	30	65	42,19	6 000	9,3	30,3	51	150	20	142	6	6,6	M6×30
TSWW40	14 250	40	85	60	6 000	16,3	46	65	150	20	139	10	9	M10×45
TSWW50	19 750	50	85	65,06	6 000	16,3	46	65	150	20	139	10	9	M10×45

- 1) In relation to the nominal shaft diameter, measured whilst clamped.
- 2) Maximum length of single-piece shaft and support rail units; longer shaft and support rail units, see page 133. Depending on the length of the shaft and support rail unit, the support rail is composed of several individual sections.
- 3) Dimensions a_L/a_R are dependent on the length of the shaft and support rail unit. Calculation, see page 135.
- 4) For fixing screws ISO 4762 or ISO 4017 (TSWW12, DIN 7984). If there is a possibility of settling, the screws should be secured against rotation.
- 5) ① The shaft may if necessary protrude on both sides beyond the support rail by approx. 3 mm.



Shaft and support rail units



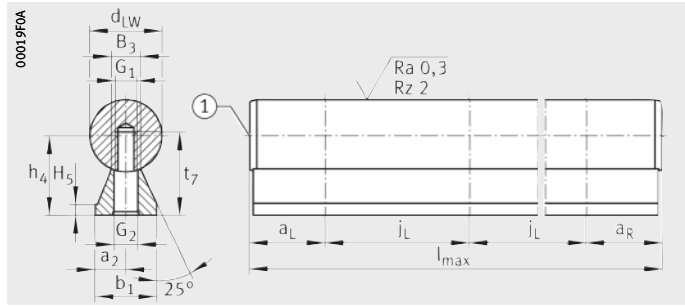
TSWWA
① ⑥

Dimension table - Dimensions in mm

Designation	Mass m ≈g/m	Dimensions				Mounting dimensions								
		d _{LW} h6	b	h ₄ ¹⁾ ±0,02	l _{max} ²⁾ ±3	b ₃	b ₄	j _B	j _L	a _L /a _R ³⁾		H ₈	K ₃ ⁴⁾	K ₇ ISO 4762
										min.	max.			
TSWWA12	1 930	12	43	28	6 000	5,4	9	29	75	20	69	5	4,5	M4×25 ⁵⁾
TSWWA16	2 800	16	48	30	6 000	7	10	33	100	20	93	5	5,5	M5×25
TSWWA20	4 120	20	56	38	6 000	8,2	11	37	100	20	92	6	6,6	M6×30
TSWWA25	5 830	25	60	42	6 000	10,4	14	42	120	20	110	6	6,6	M8×30
TSWWA30	8 500	30	74	53	6 000	11	14	51	150	20	139	8	9	M10×40

- 1) In relation to the nominal shaft diameter, measured whilst clamped.
- 2) Maximum length of single-piece shaft and support rail units; longer shaft and support rail units, see page 133.
Depending on the length of the shaft and support rail unit, the support rail is composed of several individual sections.
- 3) Dimensions a_L/a_R are dependent on the length of the shaft and support rail unit.
Calculation, see page 135.
- 4) For fixing screws ISO 4762 or ISO 4017.
If there is a possibility of settling, the fixing screws should be secured against rotation.
- 5) Screws DIN 7984.
- 6) ① The shaft protrudes on both sides beyond the support rail by approx. 2 mm.

Shaft and support rail units



TSUW
① 4)

Dimension table · Dimensions in mm

Designation	Mass m ≈g/m	Dimensions					Mounting dimensions							
		d _{LW}	b ₁	h ₄ ¹⁾	l _{max} ²⁾	a ₂	B ₃	j _L	a _L /a _R ³⁾		H ₅	G ₁	G ₂	t ₇
		h6		±0,02	±3				min.	max.				
TSUW12	1 100	12	11	14,5	6 000	5,5	5	75	20	70	3	M4	4,5	15,5
TSUW16	1 880	16	14	18	6 000	7	6,8	75	20	70	3	M5	5,5	19
TSUW20	2 920	20	17	22	6 000	8,5	7,8	75	20	69	3	M6	6,6	23
TSUW25	4 420	25	21	26	6 000	10,5	9,8	75	20	68	3	M8	9	28,5
TSUW30	6 220	30	23	30	6 000	11,5	11	100	20	92	3	M10	11	31,5
TSUW40	11 030	40	30	39	6 000	15	14,5	100	20	91	4	M12	13,5	39,5
TSUW50	16 980	50	35	46	6 000	17,5	18,5	100	20	90	5	M14	15,5	46

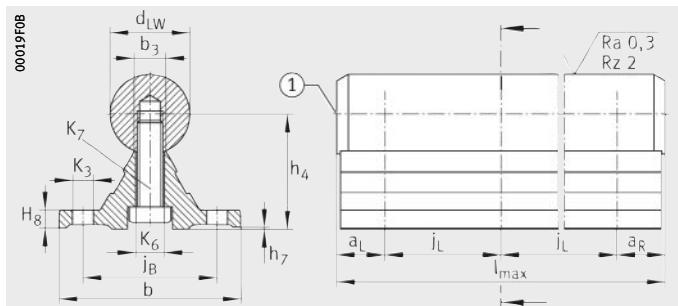
Attention!

The shaft and support rail are supplied unassembled.

- 1) In relation to the nominal shaft diameter, measured whilst clamped.
- 2) Maximum length of single-piece shaft and support rail units; longer shaft and support rail units, see page 133. Depending on the length of the shaft and support rail unit, the support rail is composed of several individual sections.
- 3) Dimensions a_L/a_R are dependent on the length of the shaft and support rail unit. Calculation, see page 135.
- 4) ① The shaft protrudes on both sides beyond the support rail by approx. 2 mm.



Shaft and support rail units



TSNW..-G4, TSNW..-G5

① ⑥

Dimension table - Dimensions in mm

Designation	Mass m ≈g/m	Dimensions				Mounting dimensions		
		d _{LW}	b	h ₄ ¹⁾	l _{max} ²⁾	b ₃	j _B	j _L
		h6			±2			
TSNW12-G4	1 600	12	40	22±0,1	4 000	5	29	75
TSNW16-G4	2 500	16	45	26±0,1	4 000	6,8	33	100
TSNW20-G4	3 800	20	52	32±0,1	4 000	7,8	37	100
TSNW25-G4	5 300	25	57	36±0,1	4 000	9,8	42	120
TSNW30-G5	7 500	30	69	42±0,15	4 000	11	51	150
TSNW40-G5	12 400	40	73	50±0,15	4 000	14,5	55	200

1) In relation to the nominal shaft diameter, measured whilst clamped.

2) Maximum length of single-piece shaft and support rail units.

3) Dimensions a_L/a_R are dependent on the length of the shaft and support rail unit. Calculation, see page 135.

4) For fixing screws DIN 7964.

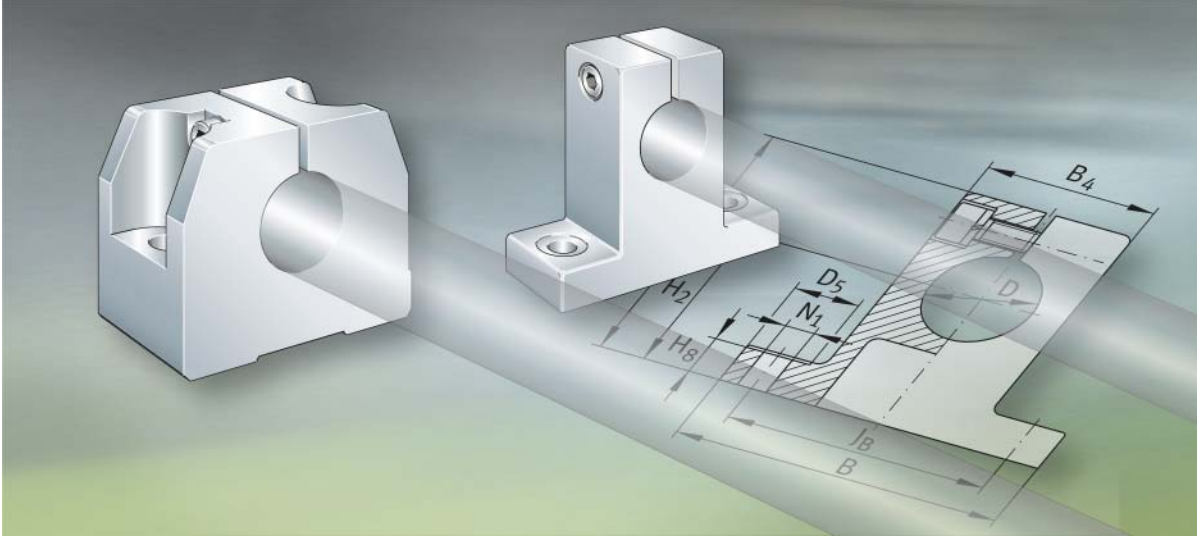
If there is a possibility of settling, the screws should be secured against rotation.

5) Maximum variation of dimension h₄, measured on the same shaft and support rail unit over a length of 1 000 mm.

6) ① The shaft protrudes on both sides beyond the support rail by approx. 2 mm.

a _L /a _R ³⁾		H ₈	h ₇	K ₃ ⁴⁾	K ₆	K ₇	Variation of h ₄ ⁵⁾	
							Accuracy class	Variation mm
min.	max.					ISO 4762		
20	69	5	0,2	4,5	4,5	M4×18	G4	0,03
20	93	5	0,2	5,5	5,5	M5×22	G4	0,03
20	92	6	0,2	6,6	6,6	M6×25	G4	0,03
20	110	6	0,3	6,6	9	M8×30	G4	0,03
20	139	7	0,3	9	11	M10×30	G5	0,04
20	189	8	0,3	9	11	M10×35	G5	0,04





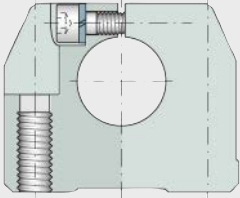
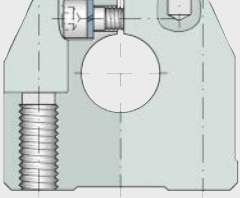
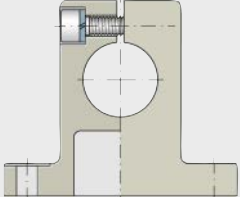
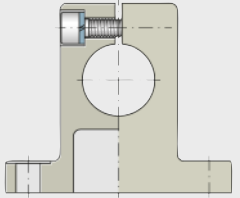
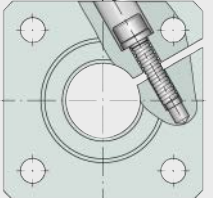
Shaft support blocks

Shaft support blocks

	Page
Matrix	Matrix for preselection of shaft support blocks 146
Product overview	Shaft support blocks 148
Features 149
Dimension tables	Shaft support blocks 150
	Shaft support block with flange 154



Matrix for preselection of shaft support blocks

Shaft support blocks	Material
<p>GWH...-B</p> 	Aluminium
<p>GWN...-B</p> 	Aluminium
<p>GW</p> 	Diecast zinc
<p>GWA...-B</p> 	Diecast zinc
<p>FW...-B</p> 	Aluminium

Definition:

- Available for stated shaft diameter d_{LW}

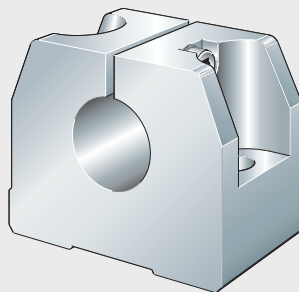
For shaft diameter d_{LW} in mm											Features	Location		Description
06	08	10	12	14	16	20	25	30	40	50		Thread	Through hole	
●	●	●	●	●	●	●	●	●	●	●	Low position of shaft	yes	yes	149
-	-	-	●	-	●	●	●	●	●	●	Suitable for dowelling	yes	yes	149
-	-	●	●	●	●	●	●	●	●	●	Space-saving design	-	yes	149
-	-	●	●	-	●	●	●	●	●	●	For larger fixing screws Space-saving design	-	yes	149
-	-	-	●	-	●	●	●	●	●	●	Suitable for dowelling	yes	yes	149



Product overview Shaft support blocks

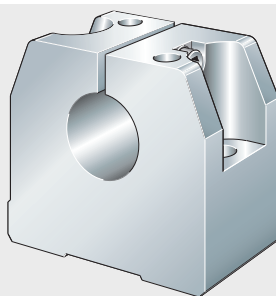
Shaft support blocks

GWH..-B



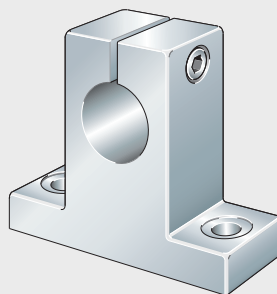
120 461

GWN..-B



120 462

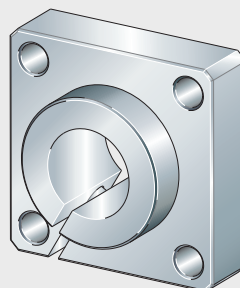
GW, GWA..-B



120 460

Shaft support block with flange

FW..-B



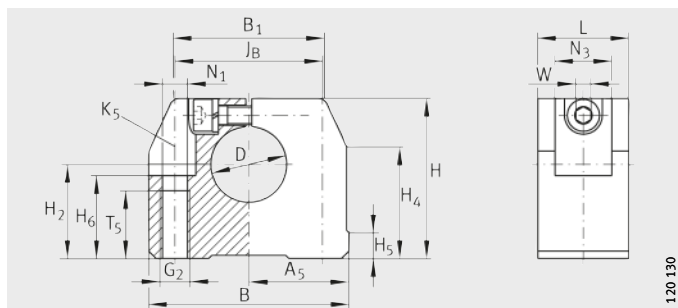
00019DF

Shaft support blocks

- Features** Shaft support blocks are used to support shafts and locate the ends of the shaft.
- They are suitable for all the solid and hollow shafts in this catalogue.
- They are made from either an aluminium alloy or pressure diecast zinc.
- Series GWA...B is identical in design to series GW but is suitable for larger fixing screws.
- Depending on the series, the shaft support blocks have through holes or threaded holes.



Shaft support blocks



GWH..-B

Dimension table - Dimensions in mm

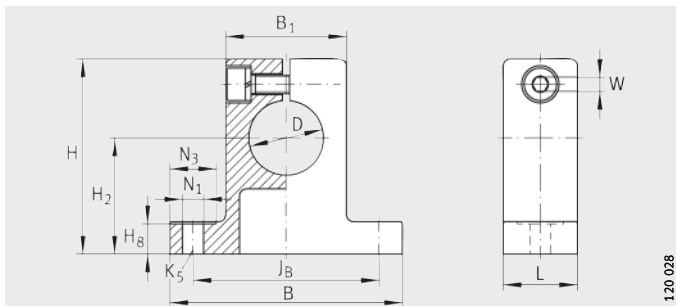
Designation	Mass m ≈g	Dimensions				Mounting dimensions													
		D H8	B	L	H	J _B ±0,15	A ₅	B ₁	H ₂ ±0,01	H ₄	H ₅	T ₅	H ₆	G ₂	N ₁	N ₃	K ₅ ¹⁾	W ²⁾	
GWH06-B	30	6	32	16	27	22	16	25	15	20,6	5	11	13	M5	4,3	10	M4	2,5	
GWH08-B	30	8	32	16	27	22	16	25	16	20,6	5	11	13	M5	4,3	10	M4	2,5	
GWH10-B	50	10	40	18	33	27	20	32	18	25,1	5	13	16	M6	5,3	11	M5	3	
GWH12-B	50	12	40	18	33	27	20	32	19	25,1	5	13	16	M6	5,3	11	M5	3	
GWH14-B	70	14	43	20	36,5	32	21,5	34	20	28,1	6,9	13	18	M6	5,3	11	M5	3	
GWH16-B	70	16	43	20	36,5	32	21,5	34	22	28,1	6,9	13	22	M6	5,3	11	M5	3	
GWH20-B	120	20	53	24	42,5	39	26,5	40	25	29,8	7,4	18	22	M8	6,6	15	M6	4	
GWH25-B	170	25	60	28	52,5	44	30	44	31	36,6	9,9	22	26	M10	8,4	18	M8	5	
GWH30-B	220	30	67	30	60	49	33,5	49,5	34	42,7	8	22	29	M10	8,4	18	M8	5	
GWH40-B	480	40	87	40	73,5	66	43,5	63	42	49,7	12,8	26	38	M12	10,5	20	M10	6	
GWH50-B	820	50	103	50	92	80	51,5	74	50	62,3	10,9	34	46	M16	13,5	24	M12	8	

¹⁾ For fixing screws ISO 4762-8.8.

If there is a possibility of settling, the screws should be secured against rotation.

²⁾ Width across flats.

Shaft support blocks



GW, GWA..-B

120 028

Dimension table · Dimensions in mm

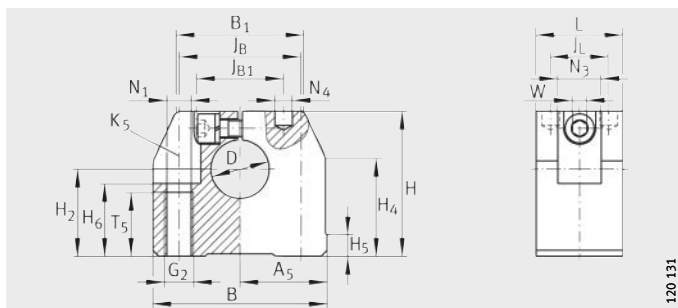
Designation	Mass m ≈g	Dimensions				Mounting dimensions							
		D	B	L	H	JB	B1	H2	H8	N1 ¹⁾	N3	K5	Width across flats W
GW10	30	10	37	11	30	28±0,15	18	17	5	3,4	8	M3	2,5
GWA10-B										4,5	9	M4	
GW12	40	12	42	12	35	32±0,15	20	20	5,5	4,5	10	M4	3
GWA12-B										5,5	11	M5	
GW14	60	14	46	14	38	36±0,15	23	22	6	4,5	10	M4	3
GWA14-B										5,5	11	M5	
GW16	80	16	50	16	42	40±0,15	26	25	6,5	4,5	10	M4	3
GWA16-B										5,5	11	M5	
GW20	150	20	60	20	50	45±0,15	32	30	7,5	4,5	10	M4	3
GWA20-B										5,5	11	M5	
GW25	260	25	74	25	58	60±0,15	38	35	8,5	5,5	11	M5	4
GWA25-B										6,6	13	M6	
GW30	380	30	84	28	68	68±0,2	45	40	9,5	6,6	13	M6	5
GWA30-B										9	18	M8	
GW40	670	40	108	32	86	86±0,2	56	50	12	9,1	18	M8	6
GWA40-B										11,1	22	M10	
GW50	1 380	50	130	40	100	108±0,2	80	60	14	9	18	M8	6
GWA50-B										11	22	M10	

¹⁾ For fixing screws ISO 4762-8.8.

If there is a possibility of settling, the screws should be secured against rotation.



Shaft support blocks



120 131

GWN..-B

Dimension table - Dimensions in mm

Designation	Mass m	Dimensions				Mounting dimensions				
		D	B	L	H	J _B	J _{B1}	B ₁	A ₅	J _L
	≈g	H8							±0,01	
GWN12-B	60	12	43	20	35	30±0,15	20	34	21,5	13
GWN16-B	100	16	53	24	42	38±0,15	26	40	26,5	16
GWN20-B	170	20	60	30	50	42±0,15	30	44	30	20
GWN25-B	330	25	78	38	60	56±0,15	40	60	39	25
GWN30-B	450	30	87	40	70	64±0,15	45	63	43,5	26
GWN40-B	850	40	108	48	90	82±0,15	65	76	54	32
GWN50-B	1 400	50	132	58	105	100±0,2	70	90	66	36

¹⁾ Centring for dowel hole.

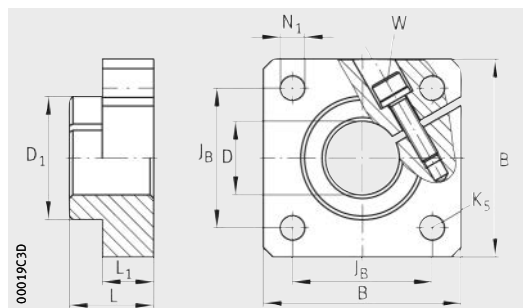
²⁾ For fixing screws ISO 4762-8.8.

If there is a possibility of settling, the screws should be secured against rotation.

H ₂ ±0,01	H ₄	H ₅	T ₅	H ₆	G ₂	N ₁	N ₄ ¹⁾	N ₃	K ₅ ²⁾	Width across flats W
20	26,6	5,4	13	16,5	M6	5,3	4	10	M5	3
25	26,6	5,4	18	21	M8	6,6	5	11	M6	4
30	34,1	7,4	22	25	M10	8,4	6	15	M8	5
35	41,5	8,3	26	30	M12	10,5	8	18	M10	6
40	46,2	9,3	26	34	M12	10,5	8	18	M10	6
50	57,6	11,7	34	44	M16	13,5	10	20	M12	8
60	62	10,6	43	49	M20	17,5	12	26	M16	10



Shaft support block with flange



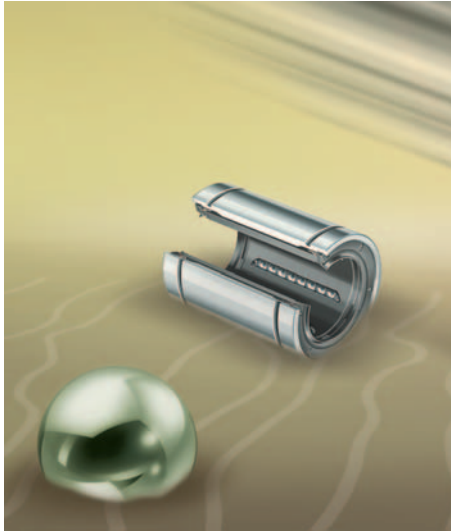
FW-B

Dimension table - Dimensions in mm

Designation	Mass m ≈g	Dimensions			Mounting dimensions					
		D H8	B	L	L ₁	D ₁	N ₁ H13	K ₅ ¹⁾	J _B	Width across flats W
FW12-B	50	12	40	20	12	23,5	5,5	M5	30	3
FW16-B	80	16	50	20	12	27,5	5,5	M5	35	3
FW20-B	100	20	50	23	14	33,5	6,6	M6	38	4
FW25-B	160	25	60	25	16	42	6,6	M6	42	5
FW30-B	260	30	70	30	19	49,5	9	M8	54	6
FW40-B	700	40	100	40	26	65	11	M10	68	8
FW50-B	900	50	100	50	36	75	11	M10	75	8

¹⁾ For fixing screws ISO 4762-8.8.

If there is a possibility of settling, the screws should be secured against rotation.



Schaeffer Technologies GmbH & Co. KG

Linear Technology Division
Berliner Straße 134
66424 Homburg/Saar (Germany)
Internet www.ina.com
E-mail info.linear@schaeffler.com

In Germany:

Phone 0180 5003872
Fax 0180 5003873

From other countries:

Phone +49 6841 701-0
Fax +49 6841 701-2625

ALMOTION B.V.

Nijverheidsweg 14
6662 NG Elst (Gld)
The Netherlands

t +31(0)85 0491 777

e info@almotion.nl

www.almotion.nl

www.lineairegeleiding.nl

www.lineairegeleidingshop.nl

www.linearmotion.nl