

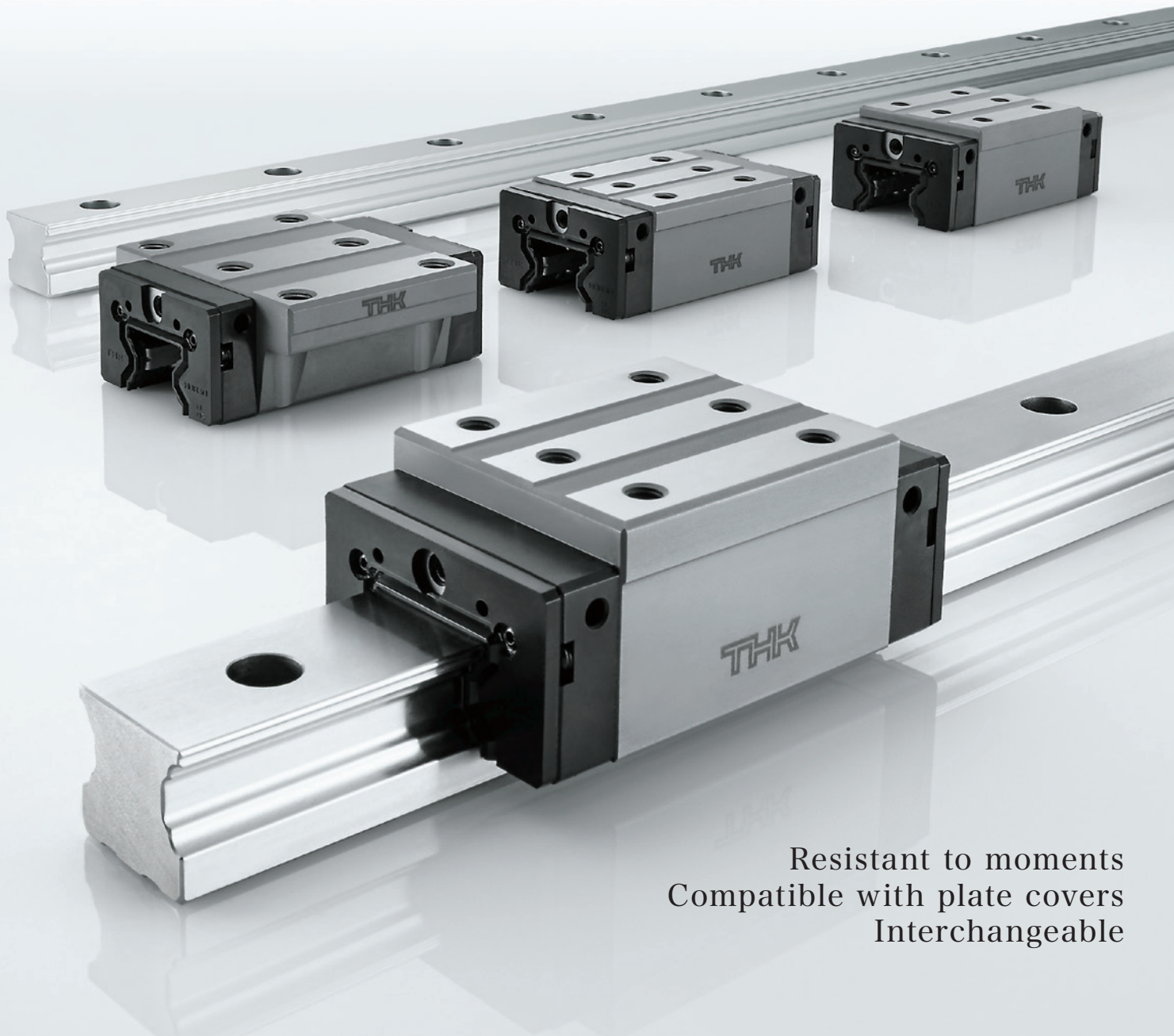

NEW

Suited for Single Rail Applications

HDR



Resistant to moments
Compatible with plate covers
Interchangeable

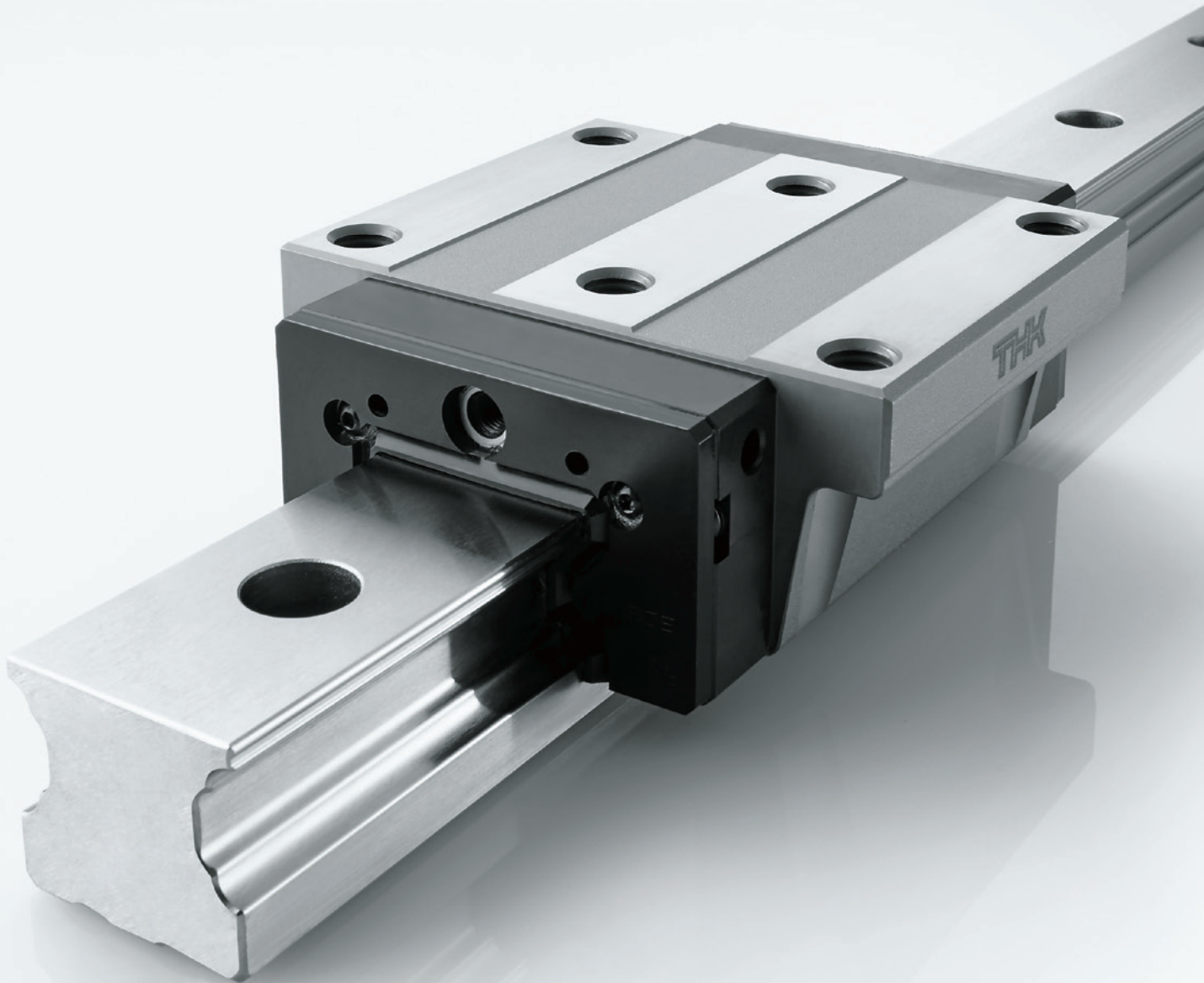

Model HDR

LM Guide

Suited for Single Rail Applications

Feature 1 Suited for Single Rail Applications p. 3

The Model HDR was designed to be used even in tables configured for one LM Guide. It enables single-axis tables to be compact and lightweight.

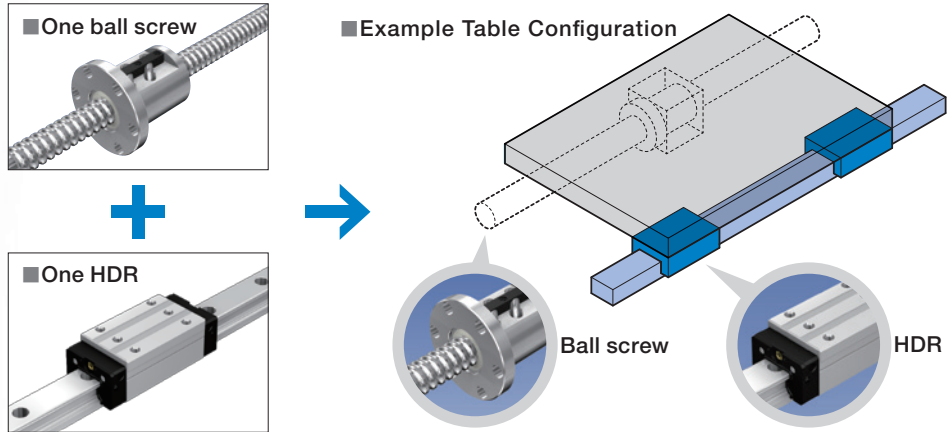

Feature 2 LM Rail Surface Protected from Foreign Materials p. 4

The ball raceways of the Model HDR are featured on the sides of the LM rail, making it difficult for foreign materials to reach them.

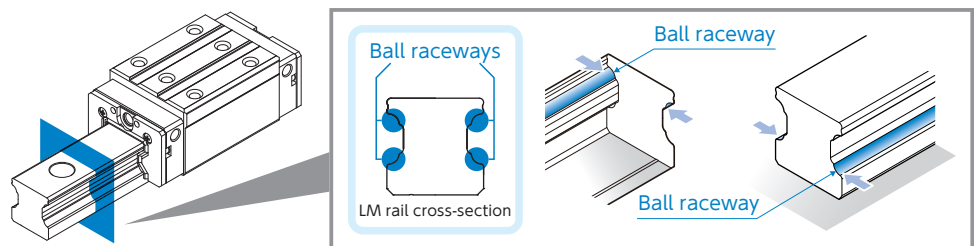

To use the product more safely, plate covers can also be installed to improve the contamination protection performance.

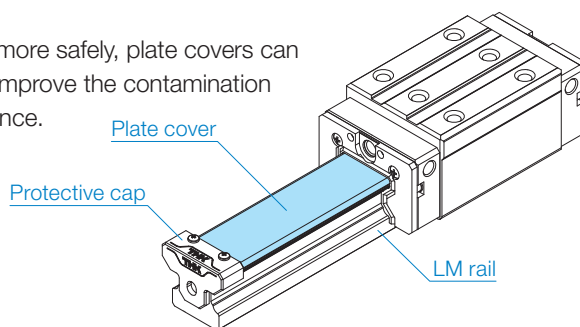

Feature 3 LM Blocks and LM Rails Available Separately p. 23

The Model HDR features a lineup of interchangeable LM blocks and LM rails that can be combined freely as long as they have the same model number. See p. 23 for details.



LM Guide Model HDR

Feature 1 Suited for Single Rail Applications

High Rigidity in the Rolling Direction

The Model HDR features a rigid design that can be used even in tables configured for one LM Guide. It enables single-axis tables to be compact and lightweight.

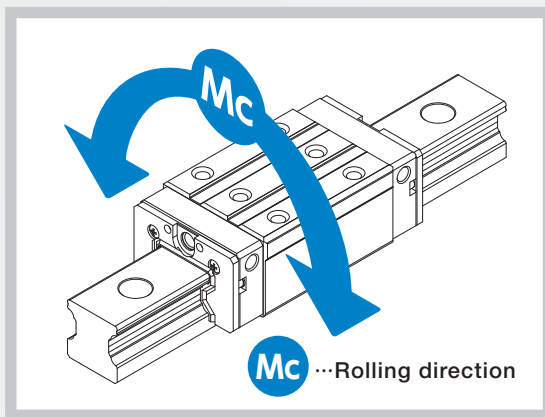

Example Table Configuration

One ball screw + One HDR

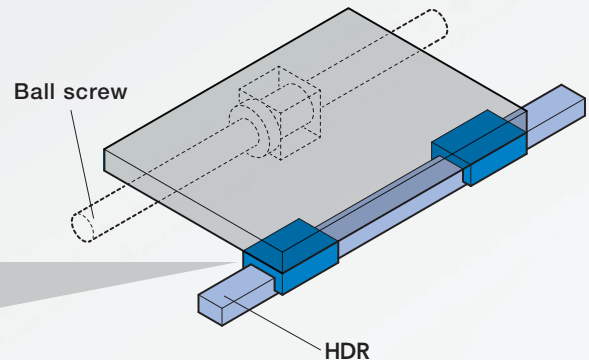

Ideal Applications

Horizontal

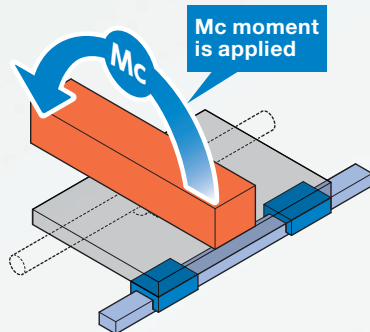

Wall-Mounted

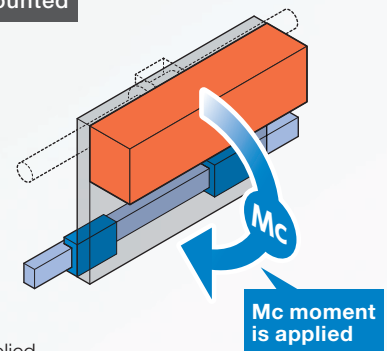

The Model HDR is ideal for applications where a constant M_c moment will be applied, such as configurations where an object will hang over the side of the table, or where the table is wall-mounted.

Other Single-Axis Configurations Where the Model HDR Excels

Vertical

When you need a vertical table configuration that is lighter and more compact.

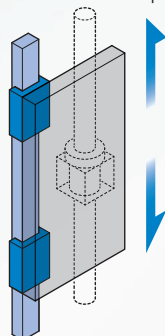

Inverted

When you need a thin design that can still reduce horizontal vibrations.

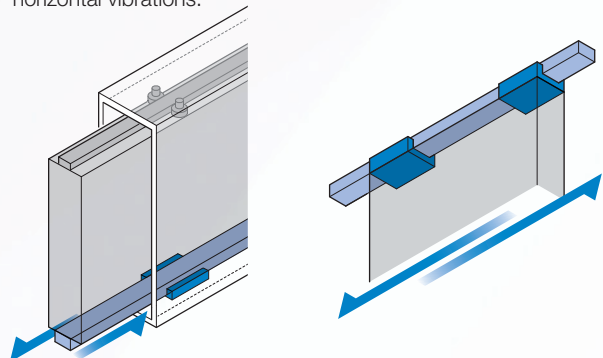

Feature 2 LM Rail Surface Protected from Foreign Materials

The ball raceways of the Model HDR are featured on the sides of the LM rail, making it difficult for foreign materials to reach them.

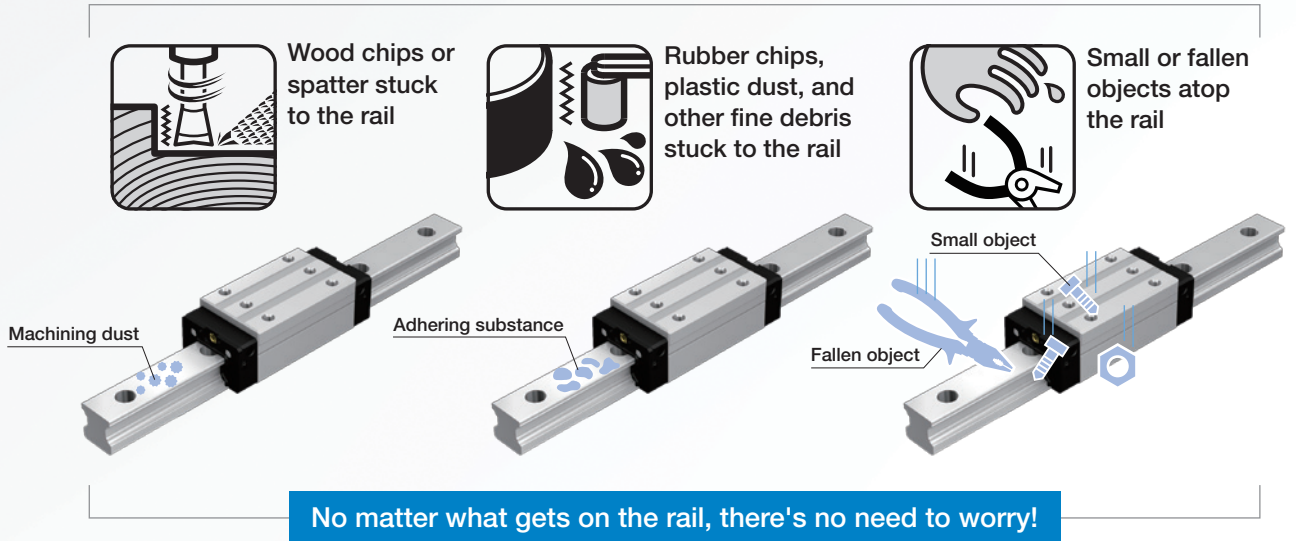

Applications where foreign materials might stick to the LM rail surface include:

- ! Woodworking machine that may produce wood chips
- ! Tire manufacturing machines where rubber might get on the rail
- ! Resin molding machines where resin may get on the rail

To use the product more safely, plate covers can also be installed to improve the contamination protection performance.

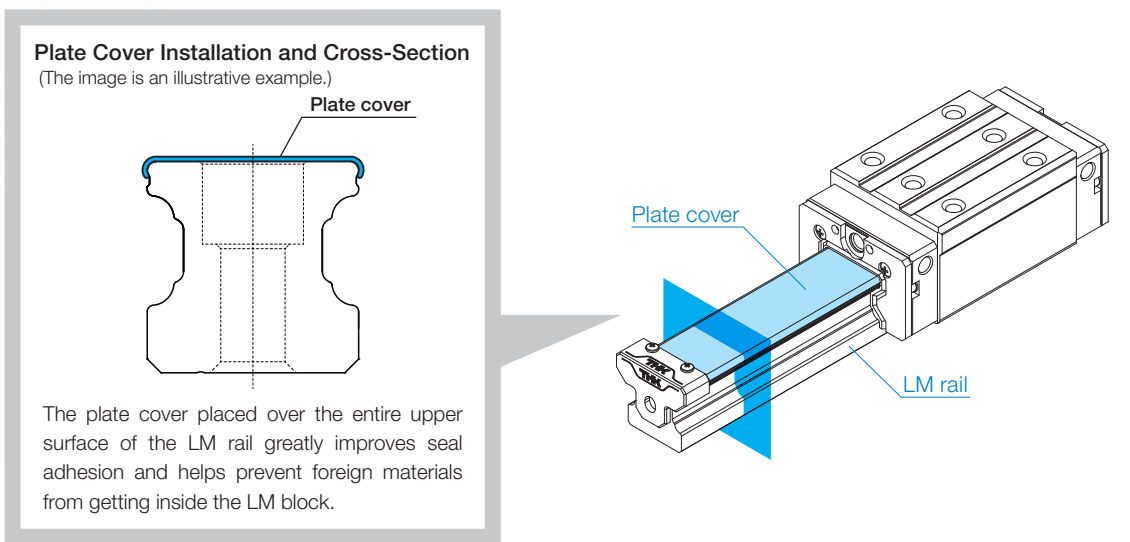

LM Guide Model HDR

Structure of the HDR

The Model HDR features raceways on the sides of the LM rail, which come into contact with the balls at a 45° angle. This design is resistant to tilt in the rolling direction.

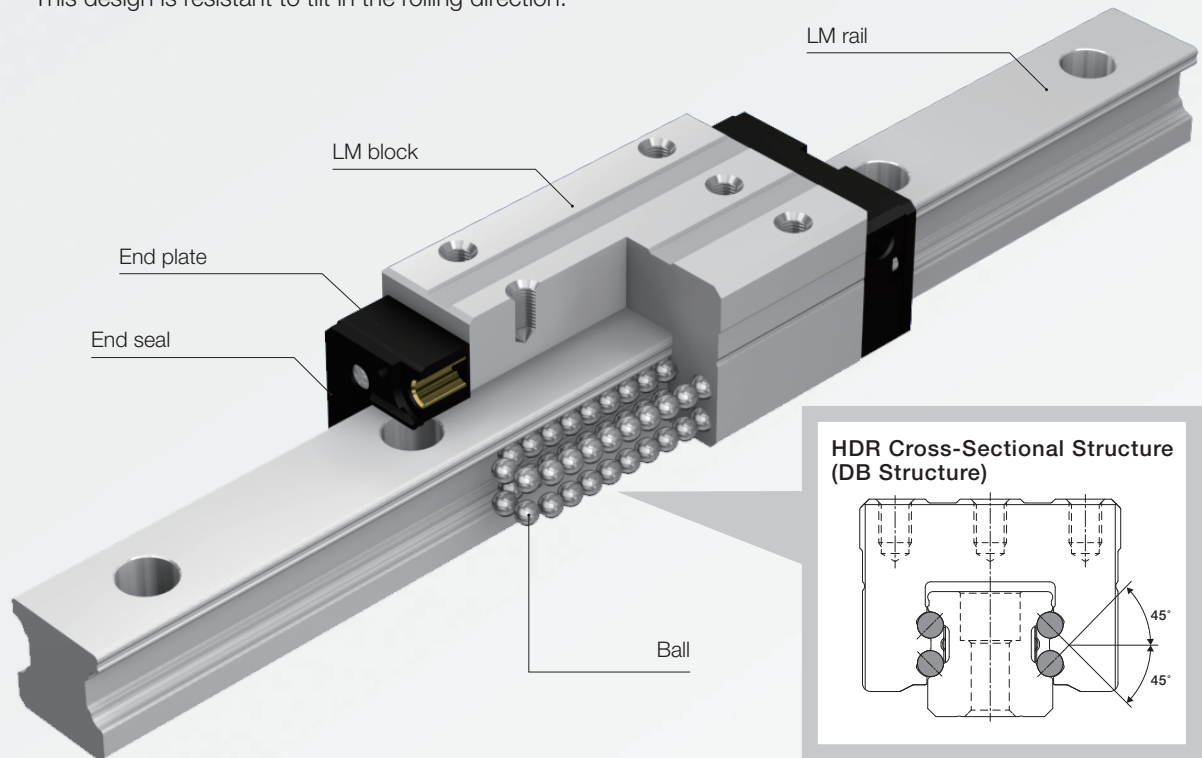

DB Structure (Back-to-Back)

This contact structure is designed so that the raceways fully support the balls even when an M_c moment is applied. As a result, this design is highly rigid and resistant to tilt in the rolling direction. It is often used in conjunction with angular ball bearings when the moment load is high.

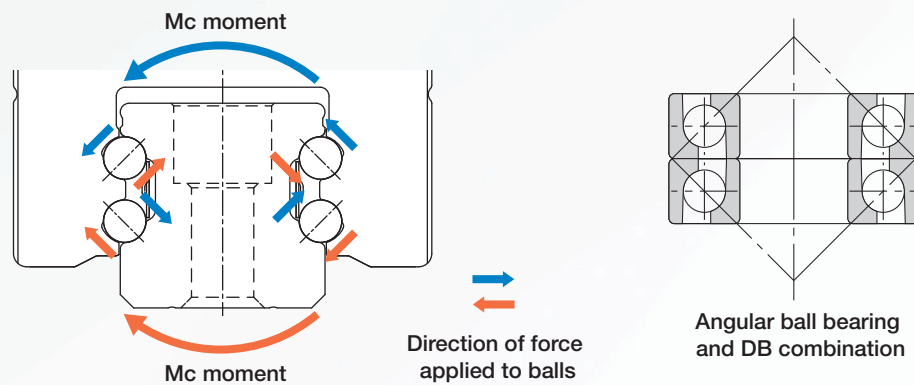

4-Way Equal Load

The Model HDR is designed to equally bear loads applied to the LM block from four directions.
 (Four directions: radial, reverse radial, left, and right)
 As a result, this model can be used in any orientation, enabling a wide variety of applications.

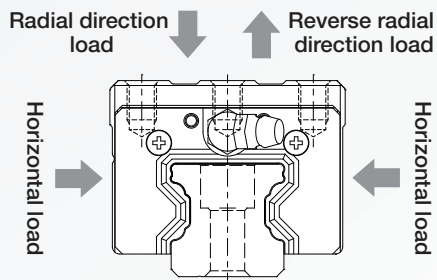

The same load can be supported from all four directions.

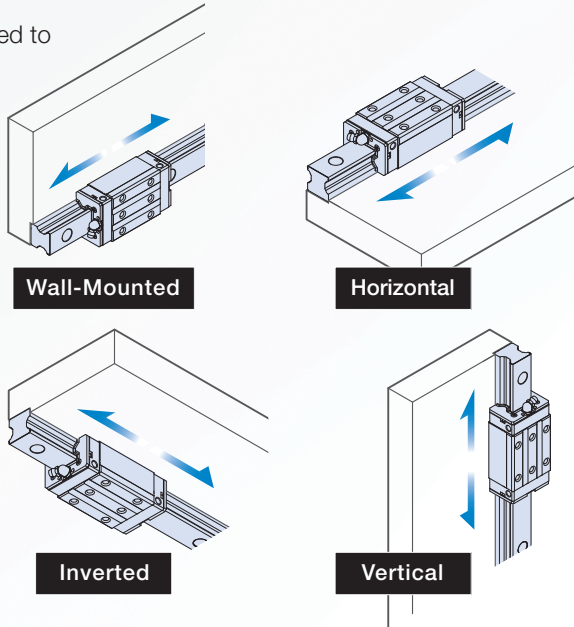

The Model HDR is equally suited for use in a horizontal orientation and any other orientation. The images are illustrative examples of LM Guide installations.

Globally Standard Dimensions

The dimensions of the HDR-C/LC, HDR-R/LR, and HDR-V/LV conform to ISO standards (ISO 12090-1:2011 Rolling Bearings). Three types of ISO-standard LM blocks and two types of LM rails are also available, creating a total lineup of six types.

HDR-C/LC	HDR-R/LR	HDR-V/LV
<p>Standard Type (C)</p> <p>Long Type (LC)</p>	<p>Standard Type (R)</p> <p>Long Type (LR)</p>	<p>Standard Type (V)</p> <p>Long Type (LV)</p>
<p>The flange of this LM block has tapped holes. This type can be mounted from the top or the bottom.</p>	<p>With this type, the LM block has a smaller width (W) and tapped holes. It is ideal for compact designs.</p>	<p>This type has an R/LR block with a shorter height and a more compact design.</p>

The dimensions conform to those of the current Model HSR, including the external dimensions, mounting holes, and mounting hole pitch.

Lineup

This model comes in eight sizes ranging from 15 to 65, and a lineup of ten block types is available: C/LC, R/LR, V/LV, UV/UW, and US/UT.

Block type		HDR15	HDR20	HDR25	HDR30	HDR35	HDR45	HDR55	HDR65
Standard type	C	○	○	○	○	○	○	○	○
	R	○	○	○	○	○	○	○	○
	V	○	—	○	○	○	○	○	—
	UV	—	○	○	—	—	—	—	—
	US	—	○	○	—	—	—	—	—
Long type	LC	○	○	○	○	○	○	○	○
	LR	○	○	○	○	○	○	○	○
	LV	○	—	○	○	○	○	○	—
Short type	UV	—	○	○	—	—	—	—	—
	US	—	○	○	—	—	—	—	—

○: Available, —: Not available

HDR-C/LC

The flange of this LM block has tapped holes. This type can be mounted from the top or the bottom.

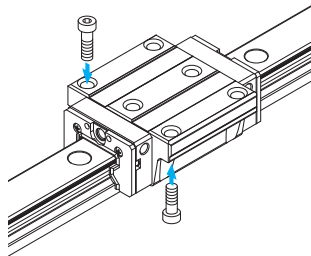

HDR-R/LR

With this type, the LM block has a smaller width (W) and tapped holes. It is ideal for compact designs.

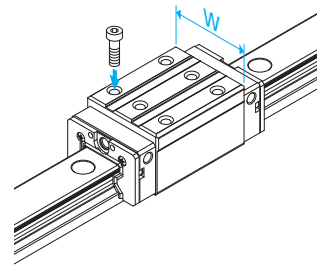

HDR-V/LV

This type has a shorter height (M) than the R/LR and a more compact design.

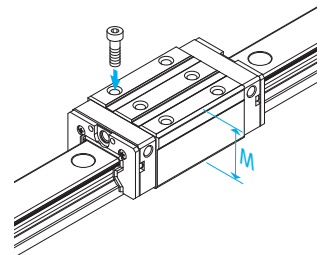

HDR-UV/UW

This type conforms to the height (M) and block width (W) of the compact-type Model SR-V/W, which features a low cross-sectional height. The M dimension is even shorter than that of the V/LV.

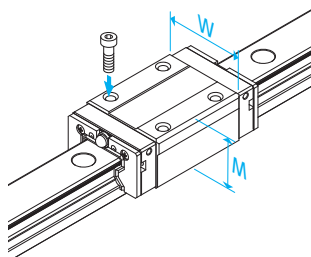

HDR-US/UT

This type conforms to the height (M) and block width (W) of the compact-type Model SR-SB/TB, which features a low cross-sectional height. The M dimension is even shorter than that of the C/LC.

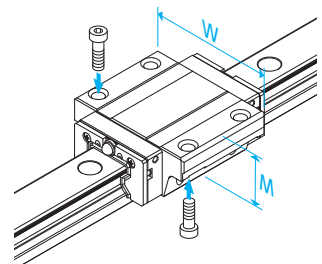

Contamination Protection Accessories

It is necessary to prevent foreign materials from getting inside the product, as it will lead to abnormal wear and a shortened service life. If it is likely that foreign materials will get inside, it is important to select an effective sealing or contamination protection device suited to the environmental conditions.

Seals

End seals made of synthetic rubber that are highly resistant to wear and side seals that further improve dust-proofing effectiveness are available. Use the symbols in the table to the right to specify if you need a contamination protection accessory.

Option Compatibility

Symbol	Contamination protection accessories
UU	End seals
SS	End seals + side seals
DD	Double seals + side seals
ZZ	End seals + side seals + metal scrapers
KK	Double seals + side seals + metal scrapers

End Seal

Used in locations exposed to dust

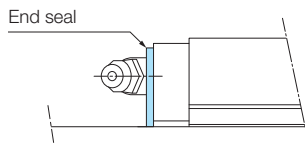

Side Seal

Used in locations where dust may enter the LM block from the side or bottom surfaces, such as vertical, horizontal, and inverted configurations

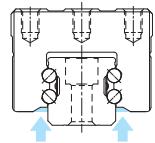

Double Seals

Used in locations exposed to excessive dust or cutting chips

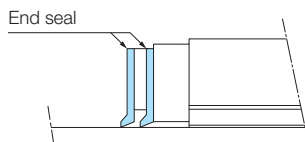

Metal Scraper (Non-Contact)

Used in locations where welding spatter may adhere to the LM rail

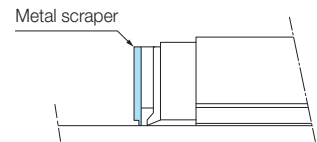

Seal Resistance Value

See the table to the right for the maximum seal resistance of SS seals per LM block when the product is lubricated.

* For the overall lengths of LM blocks with seals attached, see p. 9.

Maximum Seal Resistance

Unit: N

Model series	Seal symbol	Maximum seal resistance
HDR15	SS	7.7
HDR20		10.4
HDR25		11.7
HDR30		15.5
HDR35		19.7
HDR45		23.7
HDR55		25.5
HDR65		30.3

Laminated Contact Scraper LaCS

For locations with an adverse environment, Laminated Contact Scraper LaCS is available. LaCS removes minute foreign material adhering to the LM rail in multiple stages and prevents it from entering the LM block with a laminated contact structure (3-layer scraper).

Option Compatibility

Symbol	Contamination protection accessories
SSHH	End seals + side seals + LaCS
DDHH	Double seals + side seals + LaCS
ZZHH	End seals + side seals + metal scrapers + LaCS
KKHH	Double seals + side seals + metal scrapers + LaCS

Features

- Since the three layers of scrapers fully contact the LM rail, LaCS is highly capable of removing minute foreign material.
- Low friction resistance is achieved through the use of oil-impregnated, self-lubricating synthetic foam rubber.

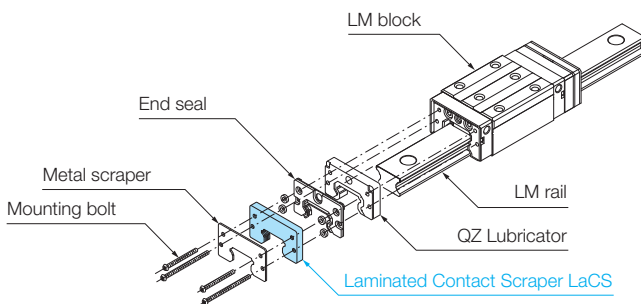

Exterior Drawing

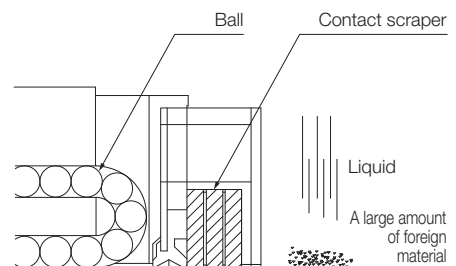

Structural Drawing

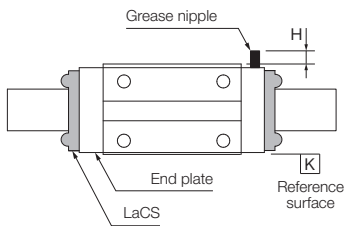

Location for mounting the side grease nipple

Dimensional Increase with a Grease Nipple

Model series	Side greasing	
	H* (mm)	Nipple type
HDR15	4.4	PB107
HDR20	4.3	PB107
HDR20U	4.4	PB107
HDR25	7.05	A-M6F
HDR25U	4.4	PB107
HDR30	7.1	A-M6F
HDR35	7.1	A-M6F
HDR45	7.1	A-M6F
HDR55	7.1	A-M6F
HDR65	6.1	A-M6F

* If HDR 15 and 20 have KK specifications, the grease nipple cannot be installed from the front. Please specify side installation.

Maximum Resistance Value when LaCS is Applied

Model series	Maximum sliding resistance* (N)
HDR15	6.2
HDR20	7.9
HDR20U	6.1
HDR25	8.7
HDR25U	10.2
HDR30	11.9
HDR35	12.5
HDR45	25.9
HDR55	31.3
HDR65	32.7

* This represents only the resistance of the LaCS and excludes resistance from the LM block and seals.

Overall LM Block Length with LaCS and Seals Attached

Unit: mm

Model series	Standard overall length (SS)	UU	DD	ZZ	KK	SSHH	DDHH	ZZHH	KKHH
HDR15	61.4	61.4	65.8	65.2	69.6	77	81.4	78.2	82.6
HDR15L	74.9	74.9	79.3	78.7	83.1	90.5	94.9	91.7	96.1
HDR20	74.9	74.9	80.1	80.7	85.9	91.3	96.5	93.7	98.9
HDR20L	90.7	90.7	95.9	96.5	101.7	107.1	112.3	109.5	114.7
HDR20UV/US	43.8	49	54.2	54.8	60	65.4	70.6	67.8	73
HDR20UW/UT	63.6	68.8	74	74.6	79.8	85.2	90.4	87.6	92.8
HDR25	87.6	87.6	92.8	93.4	98.6	105	110.2	107.4	112.6
HDR25L	104.5	104.5	109.7	110.3	115.5	121.9	127.1	124.3	129.5
HDR25UV/US	51.8	57	62.2	62.8	68	74.4	79.6	76.8	82
HDR25UW/UT	75.7	80.9	86.1	86.7	91.9	98.3	103.5	100.7	105.9
HDR30	102.1	102.1	108.7	107.8	114.4	123.4	130	125.8	132.4
HDR30L	124.1	124.1	130.7	129.8	136.4	145.4	152	147.8	154.4
HDR35	116.5	116.5	123.5	122.2	129.2	137.8	144.8	140.2	147.2
HDR35L	139.5	139.5	146.5	145.2	152.2	160.8	167.8	163.2	170.2
HDR45	145.6	145.6	152.6	153.2	160.2	171.0	178.0	174.2	181.2
HDR45L	177.3	177.3	184.3	184.9	191.9	202.7	209.7	205.9	212.9
HDR55	179.2	179.2	186.2	186.8	193.8	204.6	211.6	207.8	214.8
HDR55L	217.3	217.3	224.3	224.9	231.9	242.7	249.7	245.9	252.9
HDR65	199.2	199.2	206.6	206.8	214.2	228.6	236.0	231.8	239.2
HDR65L	258.8	258.8	266.2	266.4	273.8	288.2	295.6	291.4	298.8

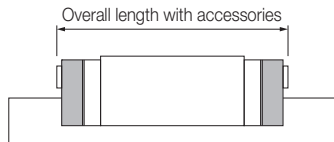

Plate Cover

A plate cover can be placed over the entire upper surface of the LM rail to better prevent foreign materials from getting inside the LM block.

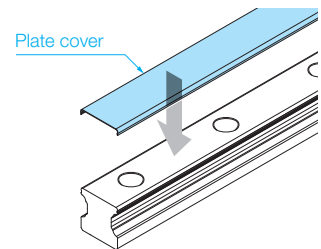
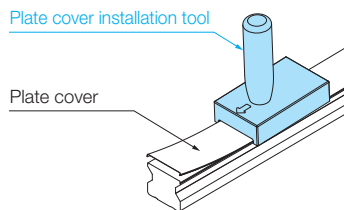

Plate cover installation tool

A plate cover installation tool and removing/mounting jig are available to make the plate cover installation process easier. Contact THK for details.

Note 1) Please order the plate cover installation tool separately.
Note 2) Each tool can be used for more than one size (see the table).



Model Number Coding

WPC-AT 15/20

Model No.
(HDR15 to 65)

Plate Cover Installation Tool Compatibility

Model No.	Model series
HDR15, HDR20	WPC-AT15/20
HDR25, HDR30, HDR35	WPC-AT25/30/35
HDR45, HDR55, HDR65	WPC-AT45/55/65

Protective Cap

Protective caps are included when a product is ordered with a plate cover. Using the protective caps will prevent injuries caused by coming in contact with the end of the plate cover.

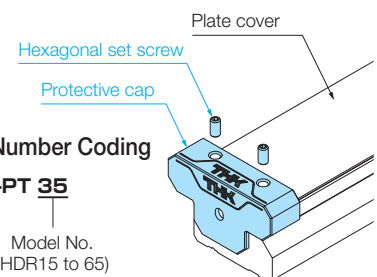

Model Number Coding

WPC-PT 35

Model No.
(HDR15 to 65)

Plate Cover Roll

An extra-long plate cover is available for you to store on-site and use for maintenance and replacements when necessary.
 Note) Please order protective caps separately.

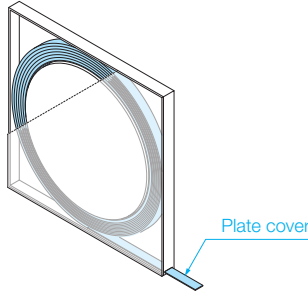

Plate cover roll introduction and installation guide (video)



<https://www.thk.com/video/wpc/en>

Model Number Coding

WPC35 - 90M

Model No. (#15 to 65) Length (90 m)

■ Dedicated Cap for LM Rail Mounting Holes

Using dedicated caps to cover the LM rail mounting holes helps prevent foreign material from entering the mounting holes and LM block.

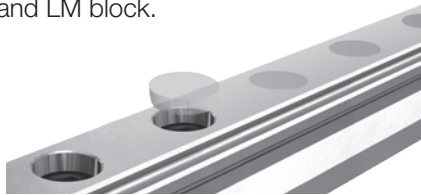

Option Compatibility

Applicable model	C cap	CV cap	GC cap
15	○	—	—
20	—	○	○
25	—	○	○
30	—	○	○
35	—	○	○
45	—	○	○
55	—	○	○
65	—	○	○

CV Caps/C Caps

The caps are made of a special synthetic resin. The CV cap is the successor to the C cap, and its new structure makes it easier to insert.

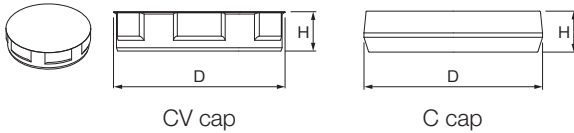

Applicable model	Cap model	Bolts used	Main dimensions (mm)	
			D	H
15	C4	M4	7.9	1.0
20	CV5	M5	9.8	2.6
25	CV6	M6	11.4	2.6
30 35	CV8	M8	14.4	3.3
45	CV12	M12	20.4	3.4
55	CV14	M14	23.4	5.5
65	CV16	M16	26.4	5.6

GC cap

GC caps are made of metal. (They are RoHS compliant.)
 GC caps adhere closer to the counterbore than CV caps and C caps, so there is no clearance once they are inserted.

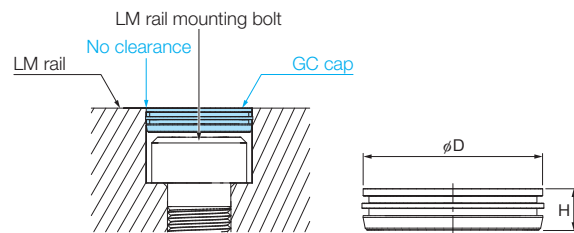

Applicable model	Cap model	Bolts used	Main dimensions (mm)	
			D	H
20	GC5	M5	9.86	2.5
25	GC6	M6	11.36	2.5
30 35	GC8	M8	14.36	3.5
45	GC12	M12	20.36	4.6
55	GC14	M14	23.36	5.0
65	GC16	M16	26.36	5.0

Note 1) GC caps are only sold with an LM Guide. They are not sold separately. The LM Guide model number code will have "GC" at the end when it is delivered.

Model Number Coding

HDR25 LV 2 UU CO + 1200L P GC

GC caps attached

- Note 2) GC caps cannot be used with LM rails that have undergone surface treatment.
- Note 3) LM rail mounting holes for GC caps are special. (The mouth is not chamfered.)
- Note 4) Be careful not to injure your hand when inserting GC caps.
- Note 5) Be sure to make the GC caps level with the upper surface of the LM rail and clean (wipe) that surface after insertion.
- Note 6) Contact THK if this product will be used in special environments such as in a vacuum, or at very low or high temperatures.

Lubrication

Standard Grease

AFB-LF Grease is a general-purpose grease that provides excellent extreme pressure resistance and mechanical stability through the use of a refined mineral oil base oil and a lithium-based consistency enhancer.

*Non-standard greases are also available. Contact THK for details.

AFB-LF Representative Physical Properties

Item	Representative property	Testing method
Consistency enhancer	Lithium-based	
Base oil	Refined mineral oil	
Base oil kinematic viscosity: mm ² /s (40°C)	170	JIS K 2220 23
Worked penetration (25°C, 60 W)	275	JIS K 2220 7
Mixing stability (100,000 W)	345	JIS K 2220 15
Dropping point: °C	193	JIS K 2220 8
Evaporation volume: mass% (99°C, 22 h)	0.4	JIS K 2220 10
Oil separation rate: mass% (100°C, 24 h)	0.6	JIS K 2220 11
Copper plate corrosion (B method, 100°C, 24 h)	Passed	JIS K 2220 9
Low-temperature torque: mN·m (-20°C)	Starting	130
	Rotational	51
4-ball testing (welding load): N	3089	ASTM D2596
Operating temperature range: °C	-15 to 100	
Color	Yellowish brown	

QZ Lubricator

The QZ Lubricator feeds the right amount of lubricant to the LM rail raceway. This allows an oil film to be constantly formed between the balls and the raceway and significantly extends the lubrication maintenance interval. The QZ Lubricator is made primarily of three components: (1) a highly oil-impregnated fiber net (which stores lubricant), (2) a high-density fiber net (which applies the lubricant to the raceways), and (3) an oil control plate (which adjusts the amount of oil being applied). The lubricant is supplied from within the QZ Lubricator using the basic principle of capillary action, as used in felt-tip pens.

Option Compatibility

Symbol	Contamination protection accessories
QZUU	End seals + QZ
QZSS	End seals + side seals + QZ
QZDD	Double seals + side seals + QZ
QZZZ	End seals + side seals + metal scrapers + QZ
QZKK	Double seals + side seals + metal scrapers + QZ
QZSSHH	End seals + side seals + LaCS + QZ
QZDDHH	Double seals + side seals + LaCS + QZ
QZZZHH	End seals + side seals + metal scrapers + LaCS + QZ
QZKKHH	Double seals + side seals + metal scrapers + LaCS + QZ

Features

- Since it compensates for oil loss, the lubrication maintenance interval can be significantly extended.
- It is an eco-friendly lubrication system that does not contaminate the surrounding area, as it feeds the right amount of lubricant to the ball raceway.

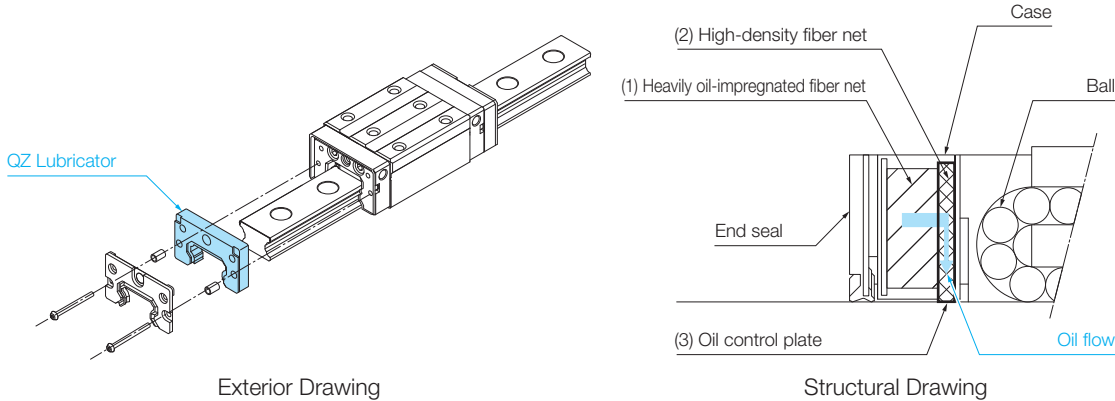

Overall LM Block Length Dimension with QZ Lubricator and Seals Attached Unit: mm

Model series	Standard overall length (SS)	QZUU	QZSS	QZDD	QZZZ	QZKK	QZSSH	QZDDH	QZZZH	QZKHH
HDR15	61.4	81.4	81.4	85.8	85.2	89.6	97	101.4	98.2	102.6
HDR15L	74.9	94.9	94.9	99.3	98.7	103.1	110.5	114.9	111.7	116.1
HDR20	74.9	94.9	94.9	100.1	100.7	105.9	111.3	116.5	113.7	118.9
HDR20L	90.7	110.7	110.7	115.9	116.5	121.7	127.1	132.3	129.5	134.7
HDR20UV/US	43.8	69	69	74.2	74.8	80	85.4	90.6	87.8	93
HDR20UW/UT	63.6	88.8	88.8	94	94.6	99.8	105.2	110.4	107.6	112.8
HDR25	87.6	107.6	107.6	112.8	113.4	118.6	125	130.2	127.4	132.6
HDR25L	104.5	124.5	124.5	129.7	130.3	135.5	141.9	147.1	144.3	149.5
HDR25UV/US	51.8	77	77	82.2	82.8	88	94.4	99.6	96.8	102
HDR25UW/UT	75.7	100.9	100.9	106.1	106.7	111.9	118.3	123.5	120.7	125.9
HDR30	102.1	122.1	122.1	128.7	127.8	134.4	143.4	150	145.8	152.4
HDR30L	124.1	144.1	144.1	150.7	149.8	156.4	165.4	172	167.8	174.4
HDR35	116.5	136.5	136.5	143.5	142.2	149.2	157.8	164.8	160.2	167.2
HDR35L	139.5	159.5	159.5	166.5	165.2	172.2	180.8	187.8	183.2	190.2
HDR45	145.6	175.6	175.6	182.6	183.2	190.2	201.0	208.0	204.2	211.2
HDR45L	177.3	207.3	207.3	214.3	214.9	221.9	232.7	239.7	235.9	242.9
HDR55	179.2	209.2	209.2	216.2	216.8	223.8	234.6	241.6	237.8	244.8
HDR55L	217.3	247.3	247.3	254.3	254.9	261.9	272.7	279.7	275.9	282.9
HDR65	199.2	229.2	229.2	236.6	236.8	244.2	258.6	266.0	261.8	269.2
HDR65L	258.8	288.8	288.8	296.2	296.4	303.8	318.2	325.6	321.4	328.8

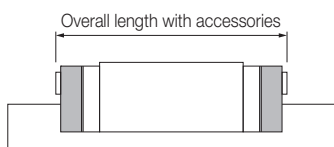

Radial Clearance Specifications

The radial clearance significantly affects the running accuracy, load resistance, and rigidity. Therefore, it is necessary to select a clearance that is appropriate for the application. An appropriate radial clearance will prevent vibrations and impacts from occurring when the device is running, as well as improve the service life and accuracy of the LM Guide. The Model HDR has three types of radial clearance (preload): normal, light preload, and medium preload.

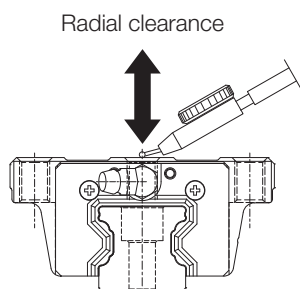

Radial Clearance Specifications Unit: μm

Model No.	Normal	Light preload	Medium preload
	No symbol	C1	C0
15	-6.0 to 0	-10 to -6.0	—
20	-8.0 to 0	-14 to -8.0	-18 to -14
20U	-9.0 to 0	-14 to -9.0	-18 to -14
25	-9.0 to 0	-16 to -11	-21 to -16
25U	-10 to 0	-17 to -13	-22 to -17
30	-11 to 0	-18 to -13	-22 to -18
35	-13 to 0	-20 to -15	-25 to -20
45	-18 to 0	-29 to -22	-37 to -29
55	-20 to 0	-34 to -27	-42 to -34
65	-23 to 0	-39 to -28	-49 to -39

Accuracy Standards

The accuracy of the LM Guide is specified for each model in terms of the dimensional tolerance for height and width, the difference between height and width in a pair, and running parallelism.

The Model HDR has five types of accuracy standards: normal grade, high accuracy grade, precision grade, super precision grade, and ultra precision grade.

■ Difference in Height M

Indicates the difference between the minimum and maximum values of height (M) of each LM Guide used on the same plane in combination.

■ Difference in Width W₂

Indicates a difference between the minimum and maximum values of the width (W₂) between each of the LM blocks, mounted on one LM rail in combination, and the LM rail.

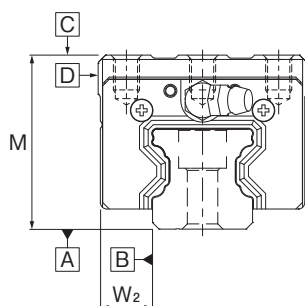

■ Running Parallelism

Refers to the tolerance for parallelism between the LM block and the LM rail datum surface when the LM block travels the whole length of the LM rail bolted to a reference surface.

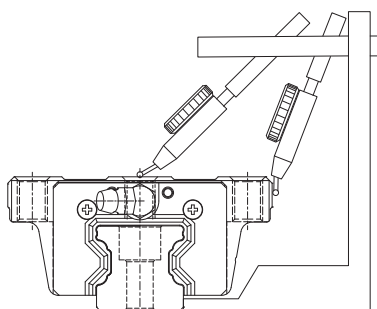

Accuracy Standards

Unit: mm

Model No.	Item	Normal grade	High accuracy grade	Precision grade	Super precision grade	Ultra precision grade
		No symbol	H	P	SP	UP
15 20	Dimensional tolerance in height (M)	±0.07	±0.03	0 -0.03	0 -0.015	0 -0.008
	Difference in height (M)	0.02	0.01	0.006	0.004	0.003
	Dimensional tolerance in width W ₂	±0.06	±0.03	0 -0.02	0 -0.015	0 -0.008
	Difference in width W ₂	0.02	0.01	0.006	0.004	0.003
	Running parallelism of surface C against surface A	See the table below for LM rail length and running parallelism by accuracy standard				
	Running parallelism of surface D against surface B	See the table below for LM rail length and running parallelism by accuracy standard				
25 30 35	Dimensional tolerance in height (M)	±0.08	±0.04	0 -0.04	0 -0.02	0 -0.01
	Difference in height (M)	0.02	0.015	0.007	0.005	0.003
	Dimensional tolerance in width W ₂	±0.07	±0.03	0 -0.03	0 -0.015	0 -0.01
	Difference in width W ₂	0.025	0.015	0.007	0.005	0.003
	Running parallelism of surface C against surface A	See the table below for LM rail length and running parallelism by accuracy standard				
	Running parallelism of surface D against surface B	See the table below for LM rail length and running parallelism by accuracy standard				
45 55	Dimensional tolerance in height (M)	±0.08	±0.04	0 -0.05	0 -0.03	0 -0.015
	Difference in height (M)	0.025	0.015	0.007	0.005	0.003
	Dimensional tolerance in width W ₂	±0.07	±0.04	0 -0.04	0 -0.025	0 -0.015
	Difference in width W ₂	0.03	0.015	0.007	0.005	0.003
	Running parallelism of surface C against surface A	See the table below for LM rail length and running parallelism by accuracy standard				
	Running parallelism of surface D against surface B	See the table below for LM rail length and running parallelism by accuracy standard				
65	Dimensional tolerance in height (M)	±0.08	±0.04	0 -0.05	0 -0.04	0 -0.03
	Difference in height (M)	0.03	0.02	0.01	0.007	0.005
	Dimensional tolerance in width W ₂	±0.08	±0.04	0 -0.05	0 -0.04	0 -0.03
	Difference in width W ₂	0.03	0.02	0.01	0.007	0.005
	Running parallelism of surface C against surface A	See the table below for LM rail length and running parallelism by accuracy standard				
	Running parallelism of surface D against surface B	See the table below for LM rail length and running parallelism by accuracy standard				

LM Rail Length and Running Parallelism by Accuracy Standard

Unit: μm

LM rail length (mm)		Running parallelism value				
Above	Or less	Normal grade	High accuracy grade	Precision grade	Super precision grade	Ultra precision grade
—	50	5	3	2	1.5	1
50	80	5	3	2	1.5	1
80	125	5	3	2	1.5	1
125	200	5	3.5	2	1.5	1
200	250	6	4	2.5	1.5	1
250	315	7	4.5	3	1.5	1
315	400	8	5	3.5	2	1.5
400	500	9	6	4.5	2.5	1.5
500	630	11	7	5	3	2
630	800	12	8.5	6	3.5	2
800	1000	13	9	6.5	4	2.5
1000	1250	15	11	7.5	4.5	3
1250	1600	16	12	8	5	4
1600	2000	18	13	8.5	5.5	4.5
2000	2500	20	14	9.5	6	5
2500	3090	21	16	11	6.5	5.5

Standard and Maximum Lengths of the LM Rail

The standard and maximum lengths of Model HDR LM rails are shown in the following table. If the maximum length of the desired LM rail exceeds these values, joint rails will be used. Contact THK for details. For special rail lengths, it is recommended to use a value corresponding to the G, g dimensions from the table. As the G, g dimensions increase, that portion becomes less stable, and the accuracy may be negatively affected.

* If joint rails are not allowed, and a length greater than the maximum values is required, contact THK.

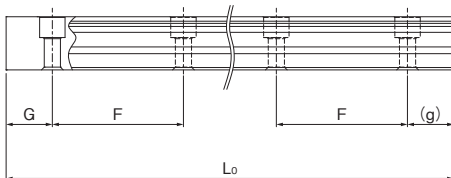

Standard and Maximum Lengths of the LM Rail

Unit: mm

Model series	HDR15	HDR20	HDR25	HDR30	HDR35	HDR45	HDR55	HDR65
LM rail standard length (L ₀)	160	160	220	280	280	570	780	1270
	220	220	280	360	360	675	900	1570
	280	280	340	440	440	780	1020	2020
	340	340	400	520	520	885	1140	2620
	400	400	460	600	600	990	1260	—
	460	460	520	680	680	1095	1380	—
	520	520	580	760	760	1200	1500	—
	580	580	640	840	840	1305	1620	—
	640	640	700	920	920	1410	1740	—
	700	700	760	1000	1000	1515	1860	—
	760	760	820	1080	1080	1620	1980	—
	820	820	940	1160	1160	1725	2100	—
	940	940	1000	1240	1240	1830	2220	—
	1000	1000	1060	1320	1320	1935	2340	—
	1060	1060	1120	1400	1400	2040	2460	—
	1120	1120	1180	1480	1480	2145	2580	—
	1180	1180	1240	1560	1560	2250	2700	—
	1240	1240	1300	1640	1640	2355	2820	—
	1360	1360	1360	1720	1720	2460	2940	—
	1480	1480	1420	1800	1800	2565	3060	—
	1600	1600	1480	1880	1880	2670	—	—
	—	1720	1540	1960	1960	2775	—	—
	—	1840	1600	2040	2040	2880	—	—
	—	1960	1720	2200	2200	2985	—	—
—	2080	1840	2360	2360	3090	—	—	
—	2200	1960	2520	2520	—	—	—	
—	—	2080	2680	2680	—	—	—	
—	—	2200	2840	2840	—	—	—	
—	—	2320	3000	3000	—	—	—	
—	—	2440	—	—	—	—	—	
Standard pitch	60	60	60	80	80	105	120	150
G, g dimension	20	20	20	20	20	22.5	30	35
Maximum length	3000	3000	3000	3000	3000	3090	3060	3000

Shoulder Height of the Mounting Base and the Corner Radius

The mounting base for the LM rail and LM block has a reference surface on the side face to allow easy installation. The height of the datum shoulder varies based on the model. See below for details. The corner of the mounting shoulder must be machined to have a recess, or machined to be smaller than the corner radius r, to prevent interference with the chamfer of the LM rail or the LM block. The corner radius r varies based on the model. See below for details.

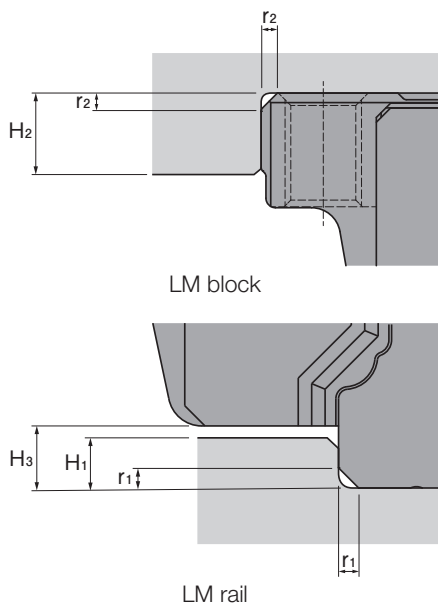

Shoulder Height of the Mounting Base and the Corner Radius

Unit: mm

Model series	LM rail corner radius r ₁ (max)	LM block corner radius r ₂ (max)	LM rail shoulder height H ₁	LM block shoulder height H ₂	H ₃
HDR15	0.5	0.5	3	4	3.8
HDR20	0.5	0.5	3.5	5	4.5
HDR20U	0.5	0.5	3.5	5	5.4
HDR25	1	1	3.6	5	4.6
HDR25U	1	1	3.6	5	5.5
HDR30	1	1	4.7	5	5.7
HDR35	1	1	5.2	6	6.2
HDR45	1	1	8	8	9.5
HDR55	1.5	1.5	10	10	12
HDR65	1.5	1.5	10	10	12.7

Specification Table

HDR-C/LC

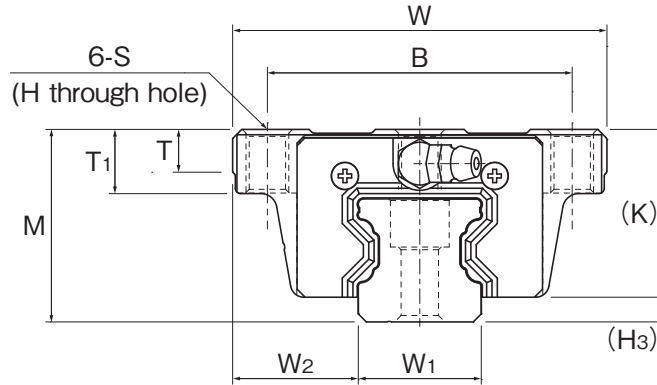

Model No.	External dimensions							LM block dimensions										Pilot hole for side nipple			
	Height	Width	Length	Pitch	Pitch	Pitch	Mounting hole	H	L ₁	T	T ₁	K	N	E	Grease nipple	e ₀	f ₀	D ₀	H ₃		
HDR15	C	24	47	61.4	38	30	26	M5	4.4	40	5.9	9.9	20.2	3.5	3.4	PB107	3.5	3.6	2.9	3.8	
	LC	24	47	74.9	38	30	26	M5	4.4	53.5	5.9	9.9	20.2	3.5	3.4	PB107	3.5	3.6	2.9	3.8	
HDR20	C	30	63	74.9	53	40	35	M6	5.4	51.7	7.2	9.9	25.5	4.7	3	PB107	3.0	4.7	2.9	4.5	
	LC	30	63	90.7	53	40	35	M6	5.4	67.5	7.2	9.9	25.5	4.7	3	PB107	3.0	4.7	2.9	4.5	
HDR25	C	36	70	87.6	57	45	40	M8	6.8	60	8	11.9	31.4	6.4	10	B-M6F	5.1	6.6	5.2	4.6	
	LC	36	70	104.5	57	45	40	M8	6.8	76.9	8	11.9	31.4	6.4	10	B-M6F	5.1	6.6	5.2	4.6	
HDR30	C	42	90	102.1	72	52	44	M10	8.5	70.5	8	14.9	36.3	7.5	9.5	B-M6F	4.8	7.5	5.2	5.7	
	LC	42	90	124.1	72	52	44	M10	8.5	92.5	8	14.9	36.3	7.5	9.5	B-M6F	4.8	7.5	5.2	5.7	
HDR35	C	48	100	116.5	82	62	52	M10	8.5	80.5	11.5	14.9	41.8	9.5	9.3	B-M6F	5.6	9.5	5.2	6.2	
	LC	48	100	139.5	82	62	52	M10	8.5	103.5	11.5	14.9	41.8	9.5	9.3	B-M6F	5.6	9.5	5.2	6.2	
HDR45	C	60	120	145.6	100	80	60	M12	10.5	104.2	14.1	17.9	50.5	10.5	14.3	B-PT1/8	8	10.5	5.2	9.5	
	LC	60	120	177.3	100	80	60	M12	10.5	135.9	14.1	17.9	50.5	10.5	14.3	B-PT1/8	8	10.5	5.2	9.5	
HDR55	C	70	140	179.2	116	95	70	M14	12.5	134.2	16	20.9	58	12	14.3	B-PT1/8	9	12	5.2	12	
	LC	70	140	217.3	116	95	70	M14	12.5	172.3	16	20.9	58	12	14.3	B-PT1/8	9	12	5.2	12	
HDR65	C	90	170	199.2	142	110	82	M16	14.5	144.8	18.8	23.9	77.3	19	14.3	B-PT1/8	10	19	5.2	12.7	
	LC	90	170	258.8	142	110	82	M16	14.5	204.4	18.8	23.9	77.3	19	14.3	B-PT1/8	10	19	5.2	12.7	

Model Number Coding

Specify the highlighted codes. *Specify each item for the models in the catalog.

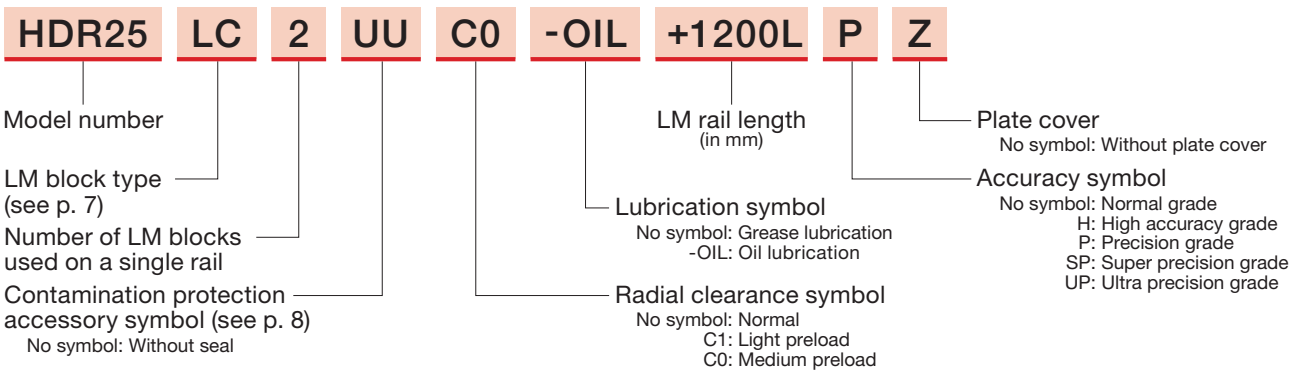

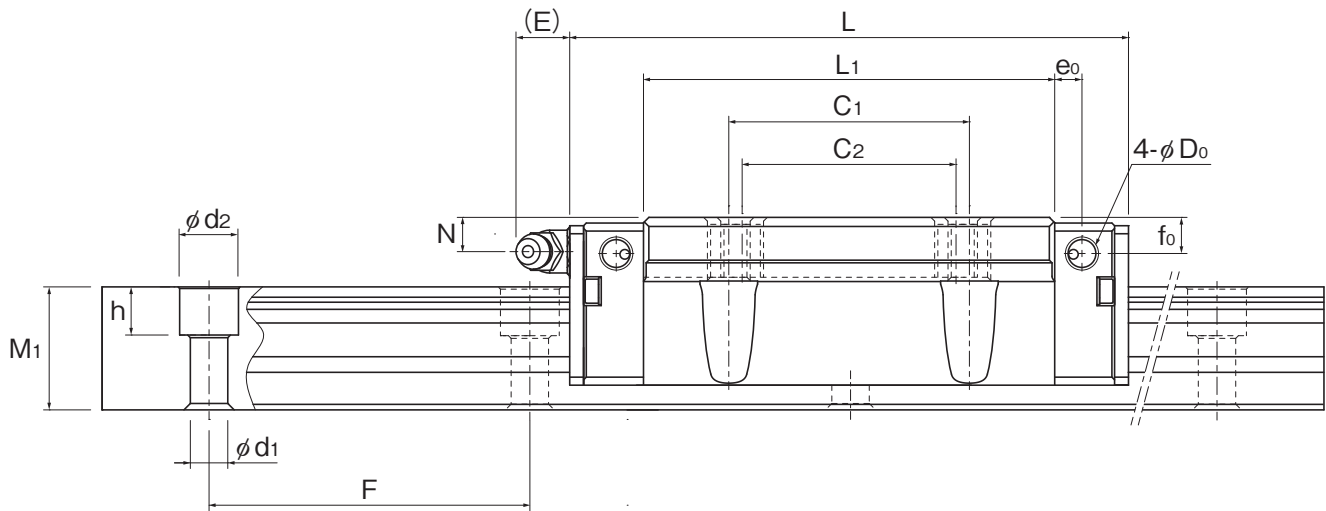

Unit: mm

	LM rail dimensions					Basic load rating (kN)		Static permissible moment* (kN·m)				Weight		
	Width	W_2	Height	Pitch	Mounting hole	C	C_0	M_A		M_B		M_C	LM block kg	LM rail kg/m
	W_1 0 -0.05		M_1	F	$d_1 \times d_2 \times h$			1 block	2 blocks	1 block	2 blocks			
	15	16	15.6	60	4.5 × 7.5 × 5.3	10.9	15.7	0.098	0.601	0.098	0.601	0.155	0.21	1.5
	15	16	15.6	60	4.5 × 7.5 × 5.3	13.7	21.7	0.182	0.984	0.182	0.984	0.215	0.28	
	20	21.5	20.1	60	6 × 9.5 × 8.5	19.8	27.4	0.227	1.27	0.227	1.27	0.348	0.46	2.5
	20	21.5	20.1	60	6 × 9.5 × 8.5	23.9	35.8	0.378	1.97	0.378	1.97	0.456	0.59	
	23	23.5	23	60	7 × 11 × 9	29.2	39.5	0.392	2.13	0.392	2.13	0.574	0.71	3.4
	23	23.5	23	60	7 × 11 × 9	33.8	48.6	0.582	3.09	0.582	3.09	0.707	0.90	
	28	31	26	80	9 × 14 × 12	40.5	53.7	0.623	3.38	0.623	3.38	0.956	1.25	4.8
	28	31	26	80	9 × 14 × 12	48.9	70.2	1.04	5.26	1.04	5.26	1.25	1.61	
	34	33	30	80	9 × 14 × 12	53.9	70.2	0.93	5.03	0.93	5.03	1.54	1.76	6.5
	34	33	30	80	9 × 14 × 12	62.4	86.4	1.38	7.32	1.38	7.32	1.9	2.23	
	45	37.5	37	105	14 × 20 × 17	86.9	110	1.82	9.82	1.82	9.82	3	3.08	10.8
	45	37.5	37	105	14 × 20 × 17	105	143	3.03	15.3	3.03	15.3	3.93	4.00	
	53	43.5	43	120	16 × 23 × 20	135	170	3.61	18.6	3.61	18.6	5.51	5.21	14.8
	53	43.5	43	120	16 × 23 × 20	161	219	5.84	28.5	5.84	28.5	7.09	6.66	
	63	53.5	54	150	18 × 26 × 22	195	228	5.27	28	5.27	28	8.79	9.38	22.3
	63	53.5	54	150	18 × 26 × 22	249	323	10.2	50.3	10.2	50.3	12.5	13.15	

*Static permissible moment 1 block: Static permissible moment value with 1 LM block
2 blocks: Static permissible moment value with 2 LM blocks in close contact with each other

Specification Table

HDR-R/LR

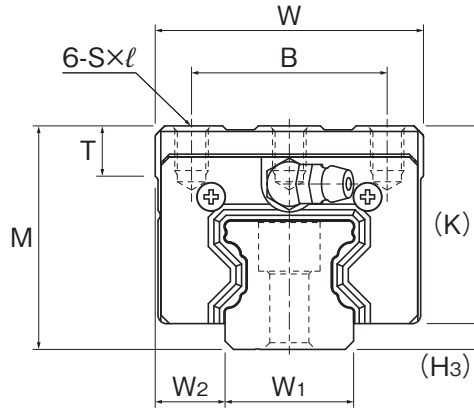

Model No.	External dimensions			LM block dimensions								Pilot hole for side nipple					
	Height M	Width W	Length L	Pitch B	Pitch C	Mounting hole S×ℓ	L ₁	T	K	N	E	Grease nipple	e ₀	f ₀	D ₀	H ₃	
HDR15	R	28	34	61.4	26	26	M4×5	40	6	24.2	7.5	3.4	PB107	3.5	7.6	2.9	3.8
	LR	28	34	74.9	26	26	M4×5	53.5	6	24.2	7.5	3.4	PB107	3.5	7.6	2.9	3.8
HDR20	R	30	44	74.9	32	36	M5×6	51.7	8	25.5	4.7	3	PB107	3.0	4.7	2.9	4.5
	LR	30	44	90.7	32	50	M5×6	67.5	8	25.5	4.7	3	PB107	3.0	4.7	2.9	4.5
HDR25	R	40	48	87.6	35	35	M6×8	60	9	35.4	10.4	10	B-M6F	5.1	10.6	5.2	4.6
	LR	40	48	104.5	35	50	M6×8	76.9	9	35.4	10.4	10	B-M6F	5.1	10.6	5.2	4.6
HDR30	R	45	60	102.1	40	40	M8×10	70.5	9	39.3	10.5	9.5	B-M6F	4.8	10.5	5.2	5.7
	LR	45	60	124.1	40	60	M8×10	92.5	9	39.3	10.5	9.5	B-M6F	4.8	10.5	5.2	5.7
HDR35	R	55	70	116.5	50	50	M8×12	80.5	11.8	48.8	16.5	9.3	B-M6F	5.6	16.5	5.2	6.2
	LR	55	70	139.5	50	72	M8×12	103.5	11.8	48.8	16.5	9.3	B-M6F	5.6	16.5	5.2	6.2
HDR45	R	70	86	145.6	60	60	M10×17	104.2	15	60.5	20.5	14.3	B-PT1/8	8	20.5	5.2	9.5
	LR	70	86	177.3	60	80	M10×17	135.9	15	60.5	20.5	14.3	B-PT1/8	8	20.5	5.2	9.5
HDR55	R	80	100	179.2	75	75	M12×18	134.2	20.5	68	22	14.3	B-PT1/8	9	22	5.2	12
	LR	80	100	217.3	75	95	M12×18	172.3	20.5	68	22	14.3	B-PT1/8	9	22	5.2	12
HDR65	R	90	126	199.2	76	70	M16×20	144.8	23	77.3	19	14.3	B-PT1/8	10	19	5.2	12.7
	LR	90	126	258.8	76	120	M16×20	204.4	23	77.3	19	14.3	B-PT1/8	10	19	5.2	12.7

Model Number Coding

Specify the highlighted codes. *Specify each item for the models in the catalog.

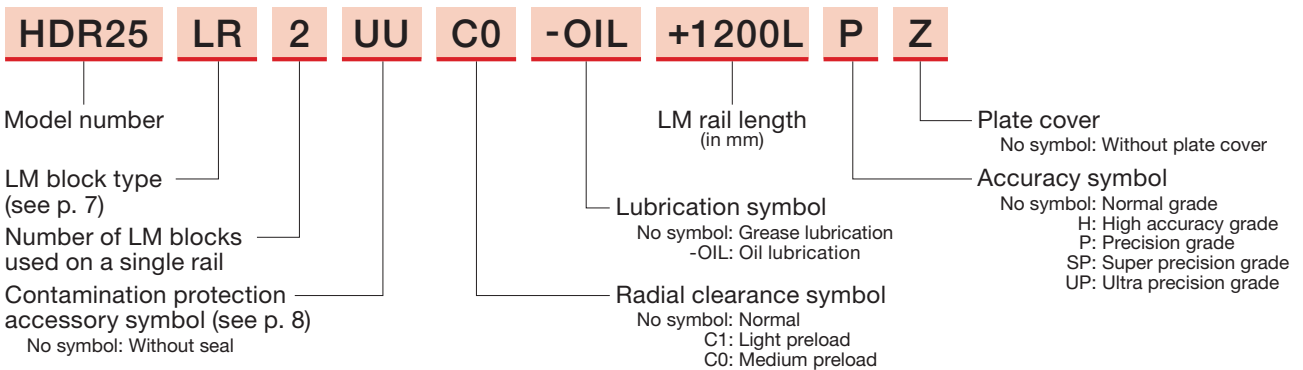

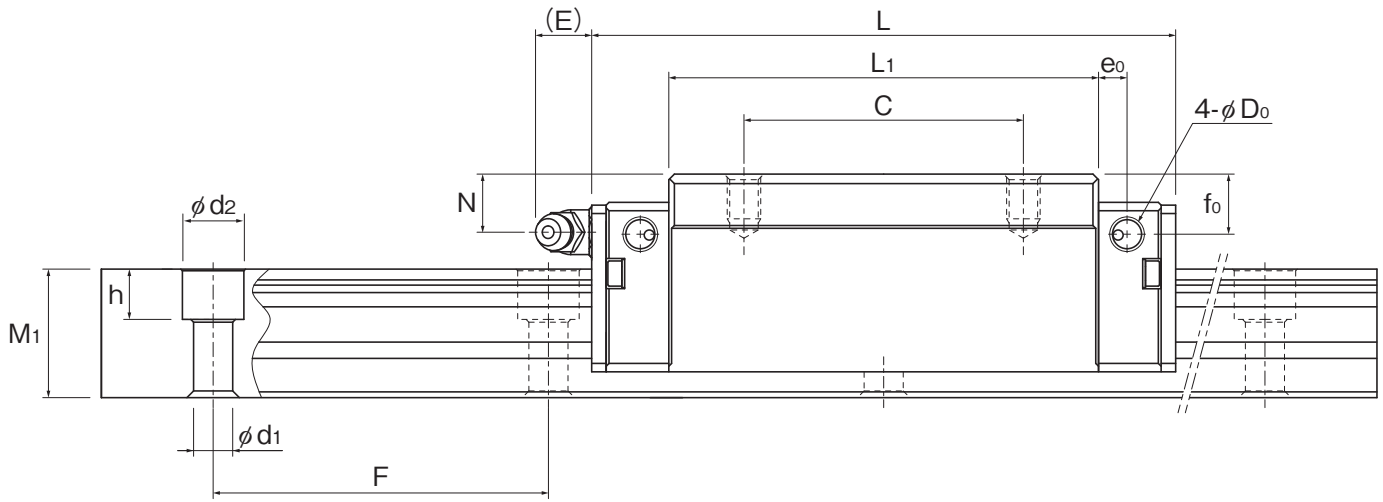

Unit: mm

	LM rail dimensions					Basic load rating (kN)		Static permissible moment* (kN·m)				Weight		
	Width	Height	Pitch	Mounting hole	C	C ₀	M _A		M _B		M _C	LM block kg	LM rail kg/m	
	W ₁ 0 -0.05	W ₂	M ₁	F			d ₁ × d ₂ × h	1 block	2 blocks	1 block				2 blocks
	15	9.5	15.6	60	4.5 × 7.5 × 5.3	10.9	15.7	0.098	0.601	0.098	0.601	0.155	0.19	1.5
	15	9.5	15.6	60	4.5 × 7.5 × 5.3	13.7	21.7	0.182	0.984	0.182	0.984	0.215	0.28	
	20	12	20.1	60	6 × 9.5 × 8.5	19.8	27.4	0.227	1.27	0.227	1.27	0.348	0.36	2.5
	20	12	20.1	60	6 × 9.5 × 8.5	23.9	35.8	0.378	1.97	0.378	1.97	0.456	0.42	
	23	12.5	23	60	7 × 11 × 9	29.2	39.5	0.392	2.13	0.392	2.13	0.574	0.64	3.4
	23	12.5	23	60	7 × 11 × 9	33.8	48.6	0.582	3.09	0.582	3.09	0.707	0.74	
	28	16	26	80	9 × 14 × 12	40.5	53.7	0.623	3.38	0.623	3.38	0.956	1.06	4.8
	28	16	26	80	9 × 14 × 12	48.9	70.2	1.04	5.26	1.04	5.26	1.25	1.37	
	34	18	30	80	9 × 14 × 12	53.9	70.2	0.93	5.03	0.93	5.03	1.54	1.75	6.5
	34	18	30	80	9 × 14 × 12	62.4	86.4	1.38	7.32	1.38	7.32	1.9	2.04	
	45	20.5	37	105	14 × 20 × 17	86.9	110	1.82	9.82	1.82	9.82	3	3.16	10.8
	45	20.5	37	105	14 × 20 × 17	105	143	3.03	15.3	3.03	15.3	3.93	4.07	
	53	23.5	43	120	16 × 23 × 20	135	170	3.61	18.6	3.61	18.6	5.51	5.28	14.8
	53	23.5	43	120	16 × 23 × 20	161	219	5.84	28.5	5.84	28.5	7.09	6.72	
	63	31.5	54	150	18 × 26 × 22	195	228	5.27	28	5.27	28	8.79	8.03	22.3
	63	31.5	54	150	18 × 26 × 22	249	323	10.2	50.3	10.2	50.3	12.5	11.17	

*Static permissible moment 1 block: Static permissible moment value with 1 LM block
2 blocks: Static permissible moment value with 2 LM blocks in close contact with each other

Specification Table

HDR-V/LV

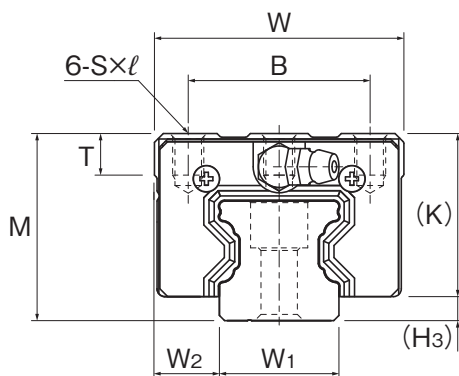

Model No.	External dimensions			LM block dimensions								Pilot hole for side nipple					
	Height M	Width W	Length L	Pitch B	Pitch C	Mounting hole S x l	L ₁	T	K	N	E	Grease nipple	e ₀	f ₀	D ₀	H ₃	
HDR15	V	24	34	61.4	26	26	M4 x 4	40	5.9	20.2	3.5	3.4	PB107	3.5	3.6	2.9	3.8
	LV	24	34	74.9	26	26	M4 x 4	53.5	5.9	20.2	3.5	3.4	PB107	3.5	3.6	2.9	3.8
HDR25	V	36	48	87.6	35	35	M6 x 8	60	8	31.4	6.4	10	B-M6F	5.1	6.6	5.2	4.6
	LV	36	48	104.5	35	50	M6 x 8	76.9	8	31.4	6.4	10	B-M6F	5.1	6.6	5.2	4.6
HDR30	V	42	60	102.1	40	40	M8 x 10	70.5	8	36.3	7.5	9.5	B-M6F	4.8	7.5	5.2	5.7
	LV	42	60	124.1	40	60	M8 x 10	92.5	8	36.3	7.5	9.5	B-M6F	4.8	7.5	5.2	5.7
HDR35	V	48	70	116.5	50	50	M8 x 12	80.5	11.5	41.8	9.5	9.3	B-M6F	5.6	9.5	5.2	6.2
	LV	48	70	139.5	50	72	M8 x 12	103.5	11.5	41.8	9.5	9.3	B-M6F	5.6	9.5	5.2	6.2
HDR45	V	60	86	145.6	60	60	M10 x 15	104.2	14.9	50.5	10.5	14.3	B-PT1/8	8	10.5	5.2	9.5
	LV	60	86	177.3	60	80	M10 x 15	135.9	14.9	50.5	10.5	14.3	B-PT1/8	8	10.5	5.2	9.5
HDR55	V	70	100	179.2	75	75	M12 x 15	134.2	19.4	58	12	14.3	B-PT1/8	9	12	5.2	12
	LV	70	100	217.3	75	95	M12 x 15	172.3	19.4	58	12	14.3	B-PT1/8	9	12	5.2	12

Model Number Coding

Specify the highlighted codes. *Specify each item for the models in the catalog.

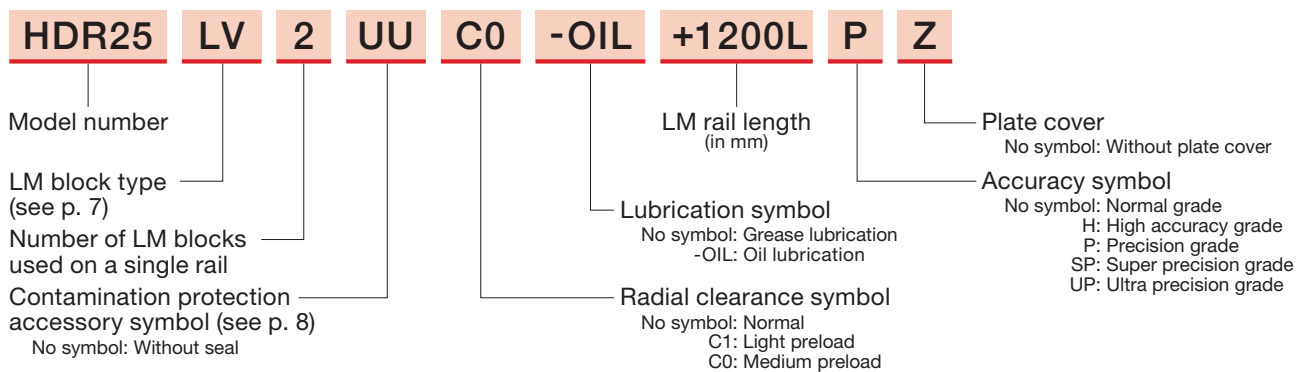

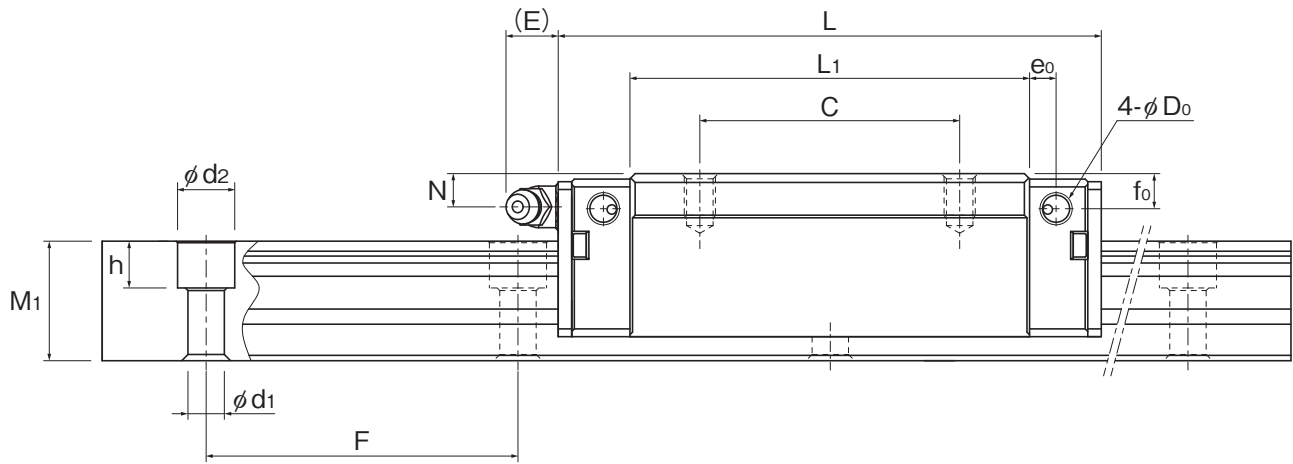

Unit: mm

	LM rail dimensions					Basic load rating (kN)		Static permissible moment* (kN·m)				Weight		
	Width	Height	Pitch	Mounting hole	C	C ₀	M _A		M _B		M _C	LM block kg	LM rail kg/m	
	W ₁ 0 -0.05	W ₂	M ₁	F			d ₁ × d ₂ × h	1 block	2 blocks	1 block				2 blocks
	15	9.5	15.6	60	4.5 × 7.5 × 5.3	10.9	15.7	0.098	0.601	0.098	0.601	0.155	0.15	1.5
	15	9.5	15.6	60	4.5 × 7.5 × 5.3	13.7	21.7	0.182	0.984	0.182	0.984	0.215	0.20	
	23	12.5	23	60	7 × 11 × 9	29.2	39.5	0.392	2.13	0.392	2.13	0.574	0.51	3.4
	23	12.5	23	60	7 × 11 × 9	33.8	48.6	0.582	3.09	0.582	3.09	0.707	0.62	
	28	16	26	80	9 × 14 × 12	40.5	53.7	0.623	3.38	0.623	3.38	0.956	0.74	4.8
	28	16	26	80	9 × 14 × 12	48.9	70.2	1.04	5.26	1.04	5.26	1.25	1.00	
	34	18	30	80	9 × 14 × 12	53.9	70.2	0.93	5.03	0.93	5.03	1.54	1.34	6.5
	34	18	30	80	9 × 14 × 12	62.4	86.4	1.38	7.32	1.38	7.32	1.9	1.65	
	45	20.5	37	105	14 × 20 × 17	86.9	110	1.82	9.82	1.82	9.82	3	2.47	10.8
	45	20.5	37	105	14 × 20 × 17	105	143	3.03	15.3	3.03	15.3	3.93	3.17	
	53	23.5	43	120	16 × 23 × 20	135	170	3.61	18.6	3.61	18.6	5.51	4.25	14.8
	53	23.5	43	120	16 × 23 × 20	161	219	5.84	28.5	5.84	28.5	7.09	5.40	

*Static permissible moment 1 block: Static permissible moment value with 1 LM block
2 blocks: Static permissible moment value with 2 LM blocks in close contact with each other

Specification Table

HDR-UV/UW

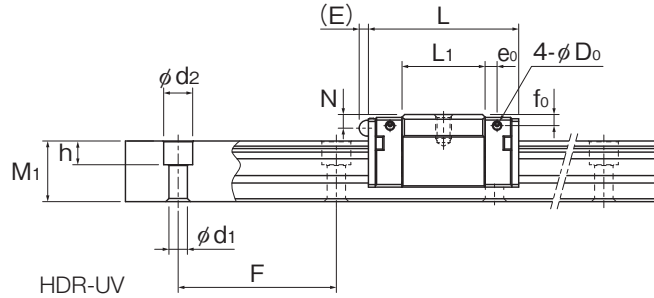
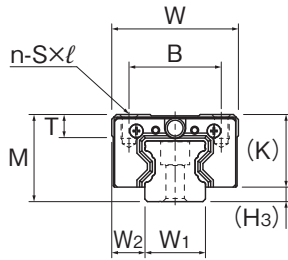

Model No.		External dimensions					n	LM block dimensions						Pilot hole for side nipple				
		Height M	Width W	Length L	Pitch B	Pitch C		Mounting hole S×ℓ	L ₁	T	K	N	E	Grease nipple	e ₀	f ₀	D ₀	H ₃
HDR20	UV	28	42	49	32	-	2	M5×7	26.3	8	22.6	3.8	3	PB107	3.55	3.56	2.9	5.4
	UW	28	42	68.8	32	32	4	M5×7	46.1	8	22.6	3.8	3	PB107	3.55	3.56	2.9	5.4
HDR25	UV	33	48	57	35	-	2	M6×9	31.5	8	27.5	5.1	3.5	PB1021B	4.55	4.16	2.9	5.5
	UW	33	48	80.9	35	35	4	M6×9	55.4	8	27.5	5.1	3.5	PB1021B	4.55	4.16	2.9	5.5

HDR-US/UT

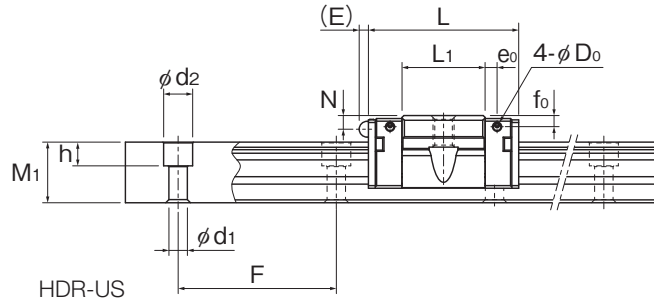
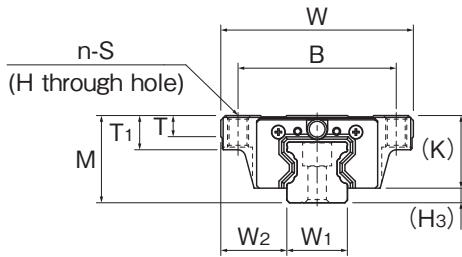

Model No.		External dimensions					n	H	LM block dimensions						Pilot hole for side nipple					
		Height M	Width W	Length L	Pitch B	Pitch C			Mounting hole S	L ₁	T	T ₁	K	N	E	Grease nipple	e ₀	f ₀	D ₀	H ₃
HDR20	US	28	59	49	49	-	2	5.4	M6	26.3	7.2	9.9	22.6	3.8	3	PB107	3.55	3.56	2.9	5.4
	UT	28	59	68.8	49	32	4	5.4	M6	46.1	7.2	9.9	22.6	3.8	3	PB107	3.55	3.56	2.9	5.4
HDR25	US	33	73	57	60	-	2	6.8	M8	31.5	8	11.9	27.5	5.1	3.5	PB1021B	4.55	4.16	2.9	5.5
	UT	33	73	80.9	60	35	4	6.8	M8	55.4	8	11.9	27.5	5.1	3.5	PB1021B	4.55	4.16	2.9	5.5

Model Number Coding

Specify the highlighted codes. *Specify each item for the models in the catalog.

HDR25	UW	2	UU	C0	-OIL	+1200L	P	Z
Model number	LM block type (see p. 7)	Number of LM blocks used on a single rail	Contamination protection accessory symbol (see p. 8) No symbol: Without seal	Radial clearance symbol No symbol: Normal C1: Light preload C0: Medium preload	Lubrication symbol No symbol: Grease lubrication -OIL: Oil lubrication	LM rail length (in mm)	Accuracy symbol No symbol: Normal grade H: High accuracy grade P: Precision grade SP: Super precision grade UP: Ultra precision grade	Plate cover No symbol: Without plate cover

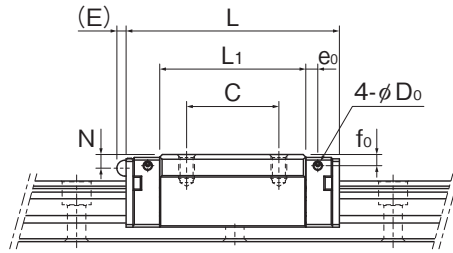

HDR-UW

Unit: mm

	LM rail dimensions					Basic load rating (kN)		Static permissible moment* (kN·m)				Weight		
	Width W_1 0 -0.05	W_2	Height M_1	Pitch F	Mounting hole $d_1 \times d_2 \times h$	C	C_0	M_A		M_B		M_C	LM block kg	LM rail kg/m
								1 block	2 blocks	1 block	2 blocks			
	20	11	20.1	60	6 × 9.5 × 8.5	12.8	14.8	0.072	0.477	0.072	0.477	0.188	0.18	2.5
	20	11	20.1	60	6 × 9.5 × 8.5	18.7	25.3	0.195	1.078	0.195	1.078	0.322	0.28	
	23	12.5	23	60	7 × 11 × 9	18.9	21.3	0.124	0.795	0.124	0.795	0.309	0.23	3.4
	23	12.5	23	60	7 × 11 × 9	27.6	36.4	0.337	1.822	0.337	1.822	0.53	0.38	

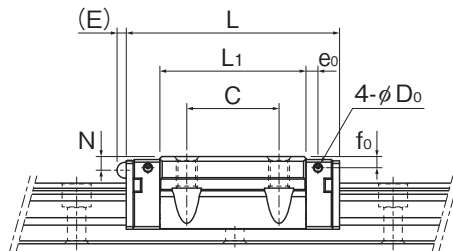

HDR-UT

Unit: mm

	LM rail dimensions					Basic load rating (kN)		Static permissible moment* (kN·m)				Weight		
	Width W_1 0 -0.05	W_2	Height M_1	Pitch F	Mounting hole $d_1 \times d_2 \times h$	C	C_0	M_A		M_B		M_C	LM block kg	LM rail kg/m
								1 block	2 blocks	1 block	2 blocks			
	20	19.5	20.1	60	6 × 9.5 × 8.5	12.8	14.8	0.072	0.477	0.072	0.477	0.188	0.24	2.5
	20	19.5	20.1	60	6 × 9.5 × 8.5	18.7	25.3	0.195	1.078	0.195	1.078	0.322	0.35	
	23	25	23	60	7 × 11 × 9	18.9	21.3	0.124	0.795	0.124	0.795	0.309	0.46	3.4
	23	25	23	60	7 × 11 × 9	27.6	36.4	0.337	1.822	0.337	1.822	0.53	0.65	

*Static permissible moment 1 block: Static permissible moment value with 1 LM block
2 blocks: Static permissible moment value with 2 LM blocks in close contact with each other

Feature 3 LM Blocks and LM Rails Available for Individual Sale

HDR-GK

LM blocks and LM rails available for individual sale

Flexible combinations, simple, quick



Lineup

Block type		HDR15	HDR20	HDR25	HDR30	HDR35	HDR45
Standard type	C	○	○	○	○	○	○
	R	○	○	○	○	○	○
	V	○	—	○	○	○	○
Long type	LC	○	○	○	○	○	○
	LR	○	○	○	○	○	○
	LV	○	—	○	○	○	○

○: Available, —: Not available

Model Number Coding

 Select an option Fixed symbol

LM rail

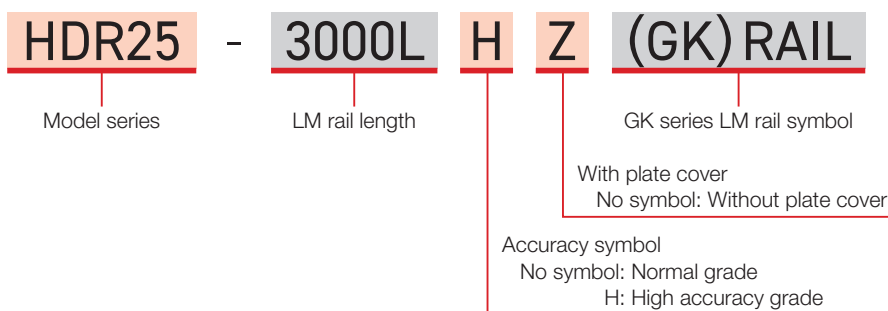

LM block

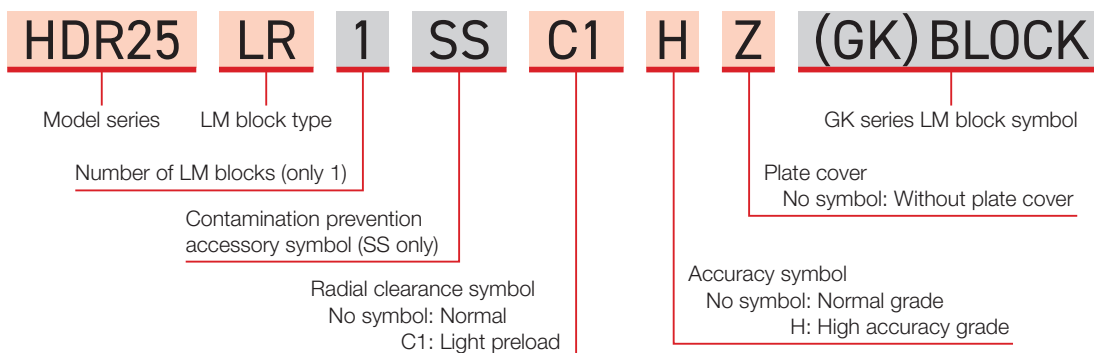

Radial Clearance Specifications

The HDR-GK has two types of radial clearance (preload): normal and light preload.

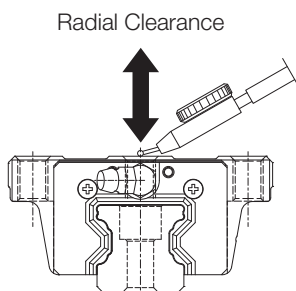

Radial Clearance Specifications Unit: μm

Model No.	Normal	Light preload
	No symbol	C1
15	-6.0 to 0	-10 to -6.0
20	-8.0 to 0	-14 to -8.0
25	-9.0 to 0	-16 to -11
30	-11 to 0	-18 to -13
35	-13 to 0	-20 to -15
45	-18 to 0	-29 to -22

Accuracy Standards

The accuracy of the LM Guide is specified for each model in terms of the dimensional tolerance for height and width, the difference between height and width in a pair, and running parallelism. The HDR-GK has two types of accuracy standards: normal grade and high accuracy grade.

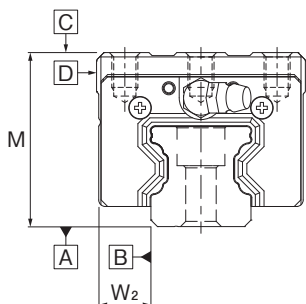

Accuracy Standards

Unit: mm

Model No.	Item		Normal grade	High accuracy grade
			No symbol	H
15 20	Dimensional tolerance in height M		± 0.07	± 0.03
	Difference in height M	Multiple blocks on a single rail (1 set)	0.02	0.01
		Multiple blocks on multiple rails (multiple sets)	0.04	0.035
	Dimensional tolerance in width W_2		± 0.06	± 0.03
	Difference in width W_2		0.02	0.01
	Running parallelism of surface C against surface A		See the table on p. 13	
Running parallelism of surface D against surface B		See the table on p. 13		
25 30 35	Dimensional tolerance in height M		± 0.08	± 0.04
	Difference in height M	Multiple blocks on a single rail (1 set)	0.02	0.015
		Multiple blocks on multiple rails (multiple sets)	0.04	0.035
	Dimensional tolerance in width W_2		± 0.07	± 0.03
	Difference in width W_2		0.025	0.015
	Running parallelism of surface C against surface A		See the table on p. 13	
Running parallelism of surface D against surface B		See the table on p. 13		
45	Dimensional tolerance in height M		± 0.08	± 0.04
	Difference in height M	Multiple blocks on a single rail (1 set)	0.025	0.015
		Multiple blocks on multiple rails (multiple sets)	0.04	0.035
	Dimensional tolerance in width W_2		± 0.07	± 0.04
	Difference in width W_2		0.03	0.015
	Running parallelism of surface C against surface A		See the table on p. 13	
Running parallelism of surface D against surface B		See the table on p. 13		

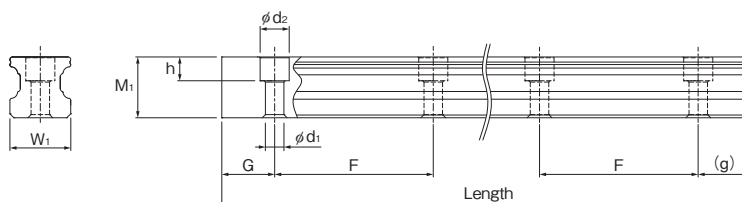

LM Rail Dimensions

Unit: mm

Model No.	LM rail dimensions					Weight
	W_1 ± 0.05	M_1	F	$d_1 \times d_2 \times h$	Length (G, g)	LM rail kg/m
15	15	15.6	60	$4.5 \times 7.5 \times 5.3$	3000 (20, 40)	1.5
20	20	20.1	60	$6 \times 9.5 \times 8.5$	3000 (20, 40)	2.5
25	23	23	60	$7 \times 11 \times 9$	3000 (20, 40)	3.4
30	28	26	80	$9 \times 14 \times 12$	3000 (20, 20)	4.8
35	34	30	80	$9 \times 14 \times 12$	3000 (20, 20)	6.5
45	45	37	105	$14 \times 20 \times 17$	3000 (20, 40)	10.8

Calculating the Static Safety Factor, Nominal Life, and Service Life Time of the HDR, HDR (GK)

Static Safety Factor

To calculate a load applied to the LM Guide, you must first obtain the average load required to determine the service life and the maximum load needed to determine the static safety factor. In particular, if the system starts and stops frequently, if a cutting load acts on the system, or if a large moment caused by an overhanging load is applied, it may experience an unexpectedly large load. When selecting a model number, make sure that the desired model is capable of supporting the required maximum load (whether stationary or in motion). The reference values for the static safety factor are shown in the table to the right.

Reference Values for the Static Safety Factor (f_s)

Machine	Load conditions	Lower limit of f _s
General industrial machinery	Without vibrations or impacts	1.0 to 3.5
	With vibrations or impacts	2.0 to 5.0
Machine tools	Without vibrations or impacts	1.0 to 4.0
	With vibrations or impacts	2.5 to 7.0

*The reference values of the static safety factor may vary depending on usage conditions such as environment, lubrication status, mounting surface accuracy, and/or rigidity.

$$f_s = \frac{C_0}{P_{max}}$$

f_s: Static safety factor
 C₀: Basic static load rating (N)
 P_{max}: Maximum applied load (N)

Nominal Life and Service Life Time

Calculating the Nominal Life

The nominal life (L₁₀) is obtained from the following formulas using the basic dynamic load rating (C) and the calculated load acting on the LM Guide (P_c). For this calculation, the basic dynamic load is to be based on a nominal life of 50 km in case of an LM Guide with balls, or 100 km in case of an LM Guide with rollers.

LM Guide with balls
 (Using a basic dynamic load rating such that the nominal life will be 50 km)

$$L_{10} = \left(\frac{C}{P_c} \right)^3 \times 50$$

L₁₀: Nominal life (km)
 C: Basic dynamic load rating (N)
 P_c: Calculated load (N)

LM Guide with rollers
 (Using a basic dynamic load rating such that the nominal life will be 100 km)

$$L_{10} = \left(\frac{C}{P_c} \right)^{\frac{10}{3}} \times 100$$

*These nominal life formulas may not apply if the length of the stroke is less than or equal to twice the length of the LM block.

When comparing the nominal life (L₁₀), you must take into account whether the basic dynamic load rating was defined based on 50 km or 100 km. Convert the basic dynamic load rating based on ISO 14728-1 as necessary.

ISO-regulated basic dynamic load rating conversion formulas:

- LM Guide with balls (Formula 1)
- LM Guide with rollers (Formula 2)

$$C_{100} = \frac{C_{50}}{1.26}$$

C₅₀: Basic dynamic load based on a nominal life of 50 km
 C₁₀₀: Basic dynamic load based on a nominal life of 100 km

$$C_{100} = \frac{C_{50}}{1.23}$$

Calculating the Modified Nominal Life

During use, an LM Guide may be subjected to vibrations and shocks as well as fluctuating loads, which are difficult to detect. In addition, the surface hardness of the raceways, the operating temperature, and having LM blocks arranged directly behind one another will have a decisive impact on the service life. Taking these factors into account, the modified nominal life (L_{10m}) can be calculated according to the following formulas (3) and (4).

Modified factor α

$$\alpha = \frac{f_H \cdot f_T \cdot f_C}{f_W}$$

α: Modified factor
 f_H: Hardness factor
 f_T: Temperature factor
 f_C: Contact factor
 f_W: Load factor

*See the general catalog for details of the hardness factor, temperature factor, contact factor, and load factor.

Modified nominal life L_{10m}:

- LM Guide with balls (Formula 3)
- LM Guide with rollers (Formula 4)

$$L_{10m} = \left(\alpha \times \frac{C}{P_c} \right)^3 \times 50$$

L_{10m}: Modified nominal life (km)
 C: Basic dynamic load rating (N)
 P_c: Calculated load (N)

$$L_{10m} = \left(\alpha \times \frac{C}{P_c} \right)^{\frac{10}{3}} \times 100$$

Once the nominal life (L₁₀) has been obtained, the service life time can be obtained using the following formula if the stroke length and the number of cycles are constant.

$$L_h = \frac{L_{10} \times 10^6}{2 \times l_s \times n_1 \times 60}$$

L_h: Service life time (h)
 l_s: Stroke length (mm)
 n₁: Cycles per minute (min⁻¹)

Handling

- (1) Please use at least two people to move any product weighing 20 kg or more, or use a cart or another method of conveyance. Otherwise, it may cause injury or damage the unit.
- (2) Do not disassemble the parts. This will result in loss of functionality.
- (3) Tilting an LM block or LM rail may cause them to fall by their own weight.
- (4) Take care not to drop or strike the LM Guide. Otherwise, it may cause injury or damage the unit. Even if there is no outward indication of damage, a sudden impact could prevent the unit from functioning properly.
- (5) Do not remove the LM block from the LM rail during setup.
- (6) Do not insert hands or fingers into the mounting holes on the LM rail, as they could get caught between the rail and the LM block, resulting in injury.
- (7) When handling the product, wear safety gloves and safety boots, etc., as appropriate to ensure proper protection.

Precautions on Use

- (1) Prevent foreign materials, such as cutting chips or coolant, from entering the product. Failure to do so could damage the product.
- (2) Prevent foreign materials, such as cutting chips, coolant, corrosive solvents, or water from getting in the product by using a bellows or cover when the product is used in an environment where such a thing is likely.
- (3) Do not use this product if the external temperature exceeds 80°C. If used above this temperature, there is a risk that the resin and rubber parts may deform or become damaged (except for the heat-resistant type).
- (4) If foreign materials such as cutting chips adhere to the product, replenish the lubricant after cleaning the product.
- (5) Micro-strokes can inhibit the formation of an oil film between the raceways and the area of contact for the balls, resulting in fretting. Therefore, be sure to use a type of grease with high fretting resistance. We recommend periodically causing the unit to make a stroke equal to the length of the LM block to help ensure that a film forms between the raceways and balls.
- (6) Do not forcibly drive a pin, key, or any other positioning device into the product. This could create indentations in the raceways and impair the product's function.
- (7) If, for operational reasons, it becomes absolutely necessary to remove the LM block from the LM rail and reattach it, a special mounting jig must be used for this purpose. (The mounting jig is not included with standard versions of the product. To obtain one, please contact THK.)
- (8) Position the mounting jig so that one end fully touches the end of the LM rail. When the rail and the jig are exactly aligned, the LM block can be loaded onto the rail.
- (9) Take care to keep the LM block straight. Loading the block at an angle can introduce foreign matter, damage internal components, or cause balls to fall out.
- (10) The LM block must contain all its internal rolling elements (balls) when mounted on the LM rail. Using a block with any balls removed may result in premature damage.
- (11) If any balls fall out of the LM block, contact THK. Do not use the product in that condition.
- (12) If the LM Guide breaks due to an accident or other cause, the block may come off of the rail and fall. For the safe use of this product, take precautions such as adding a mechanism to prevent the block from falling.
- (13) Insufficient rigidity or accuracy of the mounting surface could cause the bearing load to concentrate on one point, and the bearing performance will drop significantly. Therefore, give sufficient consideration to the rigidity and accuracy of the housing and base as well as the strength of the bolts.
- (14) When removing the LM block from the LM rail and then replacing the block, an LM block mounting/removing jig that facilitates such installation is available. Contact THK for details.

Lubrication

- (1) Thoroughly wipe off anti-rust oil and feed lubricant before using the product.
- (2) Do not mix different lubricants. Even grease containing the same type of thickening agent may, if mixed, interact negatively due to disparate additives or other ingredients.
- (3) When using the product in locations exposed to constant vibrations or in special environments such as in clean rooms, vacuums, and low/high temperatures, use a lubricant suitable for its use/environment.
- (4) Do not use grease lubrication for products whose model coding specifies "-OIL."
- (5) When lubricating products that do not feature a grease nipple or oil hole, directly coat the raceways with lubricant and perform several warm-up strokes to ensure that the grease permeates the interior.
- (6) Grease viscosity can vary depending on the temperature. Please keep in mind that the sliding resistance of the LM Guide may be affected by changes in viscosity.
- (7) After lubrication, the slide resistance of the LM Guide may increase due to the stirring resistance of grease. Be sure to let the grease spread fully before operating the machine.
- (8) Excess grease may spatter after lubrication. Wipe off spattered grease as necessary.
- (9) Grease deteriorates over time, which decreases the lubricity. It is necessary to inspect and replenish the grease in accordance with the usage frequency.
- (10) The greasing interval varies depending on the usage conditions and environment. We recommend greasing the system approximately every 100 km of travel distance (3 to 6 months). The final greasing interval/amount should be set at the actual machine.
- (11) If the product is mounted in a non-horizontal orientation, the lubricant may not reach the raceway completely.
- (12) When adopting oil lubrication, the lubricant may not be distributed throughout the LM block depending on the mounting orientation of the block. Contact THK in advance for details.

Storage

When storing the LM Guide, enclose it in the package designated by THK, and store it indoors and in a horizontal orientation while avoiding any high temperatures, low temperatures, or high levels of humidity. Please note that if the product has been kept in storage for an extended period, the lubricant inside may have deteriorated. Please ensure that you replenish the lubricant before using.

Disposal

The product should be treated as industrial waste and disposed of appropriately.

ALMOTION B.V.

Nijverheidsweg 14

6662 NG Elst (Gld)

The Netherlands

t +31(0)85 0491 777

e info@almotion.nl

www.almotion.nl

www.lineairegeleiding.nl

www.lineairegeleidingshop.nl

www.linearmotion.nl

Suited for Single Rail Applications **HDR**

● “” is a registered trademark of THK CO., LTD.

- The actual products may differ from the pictures and photographs in this catalog.
- Outward appearances and specifications are subject to change without notice for the purpose of improvement. Please consult with THK before using.
- Although great care has been taken in the production of this catalog, THK will not take any responsibility for damage resulting from typographical errors or omissions.
- For exports of our products and technologies and sales for export, our basic policy is to comply with the Foreign Exchange and Foreign Trade Act and other laws and regulations. Please consult us in advance if you want to export our products by the piece.

All rights reserved

THK CO., LTD.

Headquarters 2-12-10 Shibaura, Minato-ku, Tokyo 108-8506 Japan

International Sales Department Phone: +81-3-5730-3860

www.thk.com
