

SHS

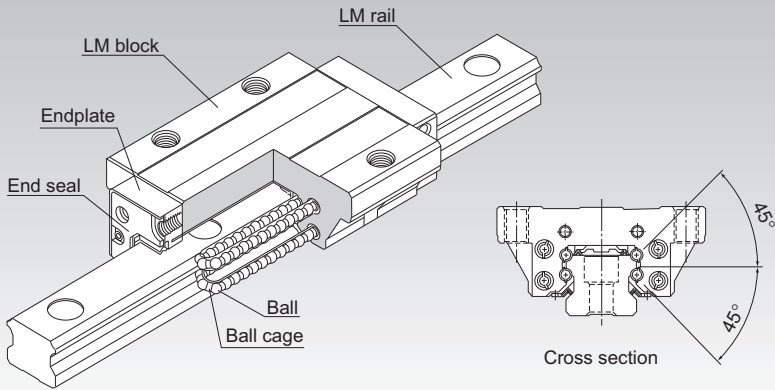

Caged Ball LM Guide Global Standard Size Model SHS



*For the Ball Cage, see **A1-88**.

Point of Selection	A1-10
Point of Design	A1-454
Options	A1-477
Model No.	A1-543
Precautions on Use	A1-549
Accessories for Lubrication	A24-1
Mounting Procedure and Maintenance	B1-89
Equivalent moment factor	A1-43
Rated Loads in All Directions	A1-59
Equivalent factor in each direction	A1-61
Radial Clearance	A1-71
Accuracy Standards	A1-77
Shoulder Height of the Mounting Base and the Corner Radius	A1-464
Permissible Error of the Mounting Surface	A1-470
Dimensions of Each Model with an Option Attached	A1-491

Structure and Features

Balls roll in four rows of raceways precision-ground on an LM rail and an LM block, and ball cages and endplates incorporated in the LM block allow the balls to circulate.

Each row of balls is placed at a contact angle of 45° so that the rated loads applied to the LM block are uniform in the four directions (radial, reverse-radial, and lateral directions), enabling the LM Guide to be used in all orientations. In addition, the LM block can receive a well-balanced preload, increasing the rigidity in the four directions while maintaining a constant, low friction coefficient.

[4-way Equal Load]

Each row of balls is placed at a contact angle of 45° so that the rated loads applied to the LM block are uniform in the four directions (radial, reverse radial and lateral directions), enabling the LM Guide to be used in all orientations and in extensive applications.

[Self-adjustment Capability]

The self-adjustment capability through front-to-front configuration of THK's unique circular-arc grooves (DF set) enables a mounting error to be absorbed even under a preload, thus to achieve highly accurate, smooth straight motion.

[Global Standard Size]

SHS is designed to have dimensions almost the same as that of Full Ball LM Guide model HSR, which THK as a pioneer of the linear motion system has developed and is practically a global standard size.

[Stainless Steel Type also Available]

A special type whose LM block, LM rail, and balls are made of stainless steel is also available. Applicable only to models 15 through 25.

Types and Features

Model SHS-C

The flange of the LM block has tapped holes.
 Can be mounted from the top or the bottom.
 Used in places where the table cannot have through holes for mounting bolts.

Specification Table⇒ **A1-96**

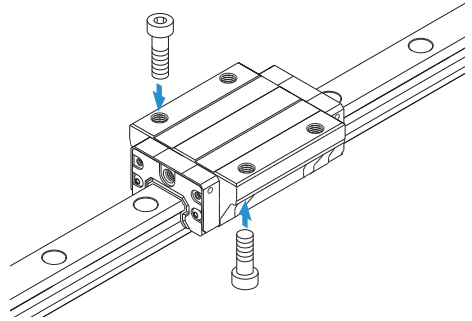

Model SHS-V

With this type, the LM block has a smaller width (W) and tapped holes.
 Used in places where the space for table width is limited.

Specification Table⇒ **A1-98**

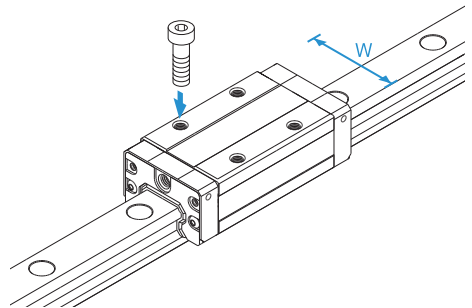

Model SHS-R

The LM block has a smaller width (W) and the mounting holes are tapped.
 It exceeds the height dimension of full-ball type LM Guide HSR-R.

Specification Table⇒ **A1-100**

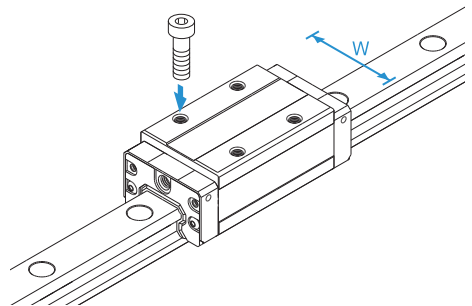

Model SHS-LC

The LM block has the same cross-sectional shape as model SHS-C, but has a longer overall LM block length (L) and a greater rated load.

Specification Table⇒ **A**1-96

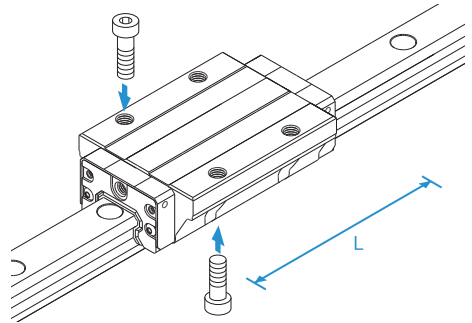

Model SHS-LV

The LM block has the same cross-sectional shape as model SHS-V, but has a longer overall LM block length (L) and a greater rated load.

Specification Table⇒ **A**1-98

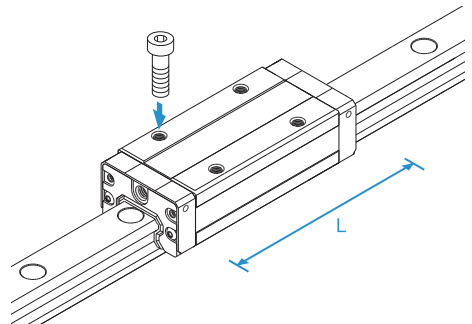

Model SHS-LR

The LM block has the same cross-sectional shape as model SHS-R, but has a longer overall LM block length (L) and a greater rated load.

Specification Table⇒ **A**1-100

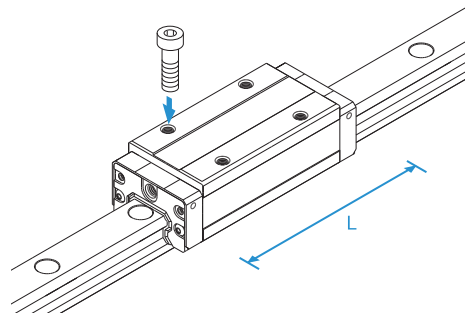

Models SHS-C, SHS-CM, SHS-LC and SHS-LCM

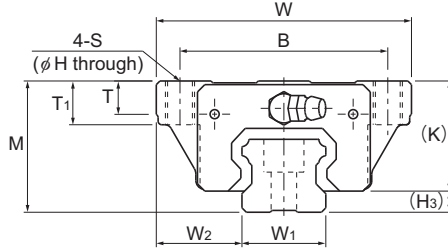

Model No.	Outer dimensions			LM block dimensions											Pilot hole for side nipple			
	Height	Width	Length												Grease nipple	e ₀	f ₀	D ₀
	M	W	L	B	C	S	H	L ₁	T	T ₁	K	N	E					
SHS 15C SHS 15CM	24	47	64.4	38	30	M5	4.4	48	5.9	8	21	5.5	5.5	PB1021B	4	4	3	
SHS 15LC SHS 15LCM	24	47	79.4	38	30	M5	4.4	63	5.9	8	21	5.5	5.5	PB1021B	4	4	3	
SHS 20C SHS 20CM	30	63	79	53	40	M6	5.4	59	7.2	10	25.4	6.5	12	B-M6F	4.3	5.3	3	
SHS 20LC SHS 20LCM	30	63	98	53	40	M6	5.4	78	7.2	10	25.4	6.5	12	B-M6F	4.3	5.3	3	
SHS 25C SHS 25CM	36	70	92	57	45	M8	6.8	71	9.1	12	30.2	7.5	12	B-M6F	4.5	5.5	3	
SHS 25LC SHS 25LCM	36	70	109	57	45	M8	6.8	88	9.1	12	30.2	7.5	12	B-M6F	4.5	5.5	3	
SHS 30C SHS 30LC	42	90	106 131	72	52	M10	8.5	80 105	11.5	15	35	8	12	B-M6F	5.8	6	5.2	
SHS 35C SHS 35LC	48	100	122 152	82	62	M10	8.5	93 123	11.5	15	40.5	8	12	B-M6F	6.5	5.5	5.2	
SHS 45C SHS 45LC	60	120	140 174	100	80	M12	10.5	106 140	14.1	18	51.1	10.5	16	B-PT1/8	8	8	5.2	
SHS 55C SHS 55LC	70	140	171 213	116	95	M14	12.5	131 173	16	21	57.3	11	16	B-PT1/8	10	8	5.2	
SHS 65C SHS 65LC	90	170	221 272	142	110	M16	14.5	175 226	18.8	24	71	19	16	B-PT1/8	10	12	5.2	

Model number coding

SHS25 LC 2 QZ KKHH C0 M +1240L P Z T M - II

Model number

Type of LM block

With QZ Lubricator

Contamination protection accessory symbol (*1)

Stainless steel LM block

LM rail length (in mm)

With steel tape

Stainless steel LM rail

No. of LM blocks used on the same rail

Radial clearance symbol (*2)
Normal (No symbol)
Light preload (C1)
Medium preload (C0)

Accuracy symbol (*3)
Normal grade (No Symbol)
High accuracy grade (H)
Precision grade (P)
Super precision grade (SP)
Ultra precision grade (UP)

Symbol for LM rail jointed use
Symbol for No. of rails used on the same plane (*4)

(*1) See contamination protection accessory on **A1-516**. (*2) See **A1-71**. (*3) See **A1-77**. (*4) See **A1-13**.

(Note) This model number indicates that a single-rail unit constitutes one set. (i.e., required number of sets when 2 rails are used in parallel is 2 at a minimum.)

Those models equipped with QZ Lubricator cannot have a grease nipple. When desiring a grease nipple for a model attached with QZ, contact THK.

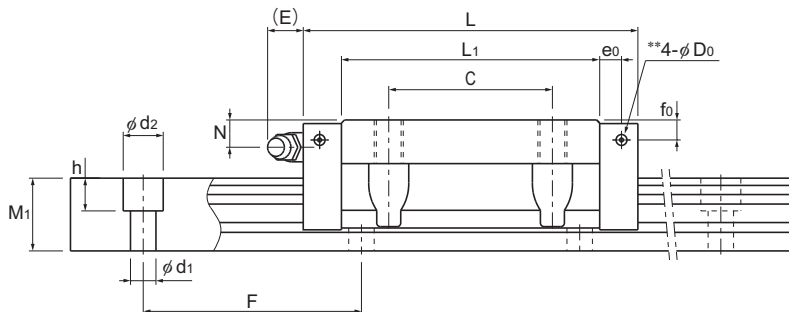

Unit: mm

H ₃	LM rail dimensions							Basic load rating		Static permissible moment kN·m*					Mass	
	W ₁ 0 -0.05	Width	Height	Pitch	d ₁ × d ₂ × h	Length*	C	C ₀	M _A		M _B		M _C	LM block kg	LM rail kg/m	
		W ₂	M ₁	F		Max			1 block	Double blocks	1 block	Double blocks	1 block			
	Note) The maximum length under "Length*" indicates the standard maximum length of an LM rail. (See A1-102 .) Static permissible moment* 1 block: the static permissible moment with one LM block Double blocks: static permissible moment when two LM blocks are in close contact with each other Total block length L : The total block length L shown in the table is the length with the dust proof parts, code UU or SS. If other contamination protection accessories or lubricant equipment are installed, the total block length will increase. (See A1-491 or A1-512) ** A pilot hole for side nipples, when a grease nipple for a model equipped with LaCS or QZ Lubricator is needed. Pilot holes for side nipples are not drilled through for models other than those stated above. For grease nipple mount machining, contact THK.															
3	15	16	13	60	4.5 × 7.5 × 5.3	3000 (1240)	14.2	24.2	0.175	0.898	0.175	0.898	0.16	0.23	1.3	
3	15	16	13	60	4.5 × 7.5 × 5.3	3000 (1240)	17.2	31.9	0.296	1.43	0.296	1.43	0.212	0.29	1.3	
4.6	20	21.5	16.5	60	6 × 9.5 × 8.5	3000 (1480)	22.3	38.4	0.334	1.75	0.334	1.75	0.361	0.46	2.3	
4.6	20	21.5	16.5	60	6 × 9.5 × 8.5	3000 (1480)	28.1	50.3	0.568	2.8	0.568	2.8	0.473	0.61	2.3	
5.8	23	23.5	20	60	7 × 11 × 9	3000 (2020)	31.7	52.4	0.566	2.75	0.566	2.75	0.563	0.72	3.2	
5.8	23	23.5	20	60	7 × 11 × 9	3000 (2020)	36.8	64.7	0.848	3.98	0.848	3.98	0.696	0.89	3.2	
7	28	31	23	80	9 × 14 × 12	3000	44.8 54.2	66.6 88.8	0.786 1.36	4.08 6.6	0.786 1.36	4.08 6.6	0.865 1.15	1.34 1.66	4.5	
7.5	34	33	26	80	9 × 14 × 12	3000	62.3 72.9	96.6 127	1.38 2.34	6.76 10.9	1.38 2.34	6.76 10.9	1.53 2.01	1.9 2.54	6.2	
8.9	45	37.5	32	105	14 × 20 × 17	3090	82.8 100	126 166	2.05 3.46	10.1 16.3	2.05 3.46	10.1 16.3	2.68 3.53	3.24 4.19	10.4	
12.7	53	43.5	38	120	16 × 23 × 20	3060	128 161	197 259	3.96 6.68	19.3 31.1	3.96 6.68	19.3 31.1	4.9 6.44	5.35 6.97	14.5	
19	63	53.5	53	150	18 × 26 × 22	3000	205 253	320 408	8.26 13.3	40.4 62.6	8.26 13.3	40.4 62.6	9.4 11.9	10.7 13.7	23.7	

Note) The maximum length under "Length*" indicates the standard maximum length of an LM rail. (See **A1-102**.)
 Static permissible moment* 1 block: the static permissible moment with one LM block
 Double blocks: static permissible moment when two LM blocks are in close contact with each other
 Total block length L : The total block length L shown in the table is the length with the dust proof parts, code UU or SS.
 If other contamination protection accessories or lubricant equipment are installed, the total block length will increase.
 (See **A1-491** or **A1-512**)
 ** A pilot hole for side nipples, when a grease nipple for a model equipped with LaCS or QZ Lubricator is needed.
 Pilot holes for side nipples are not drilled through for models other than those stated above.
 For grease nipple mount machining, contact THK.

Models SHS-V, SHS-VM, SHS-LV and SHS-LVM

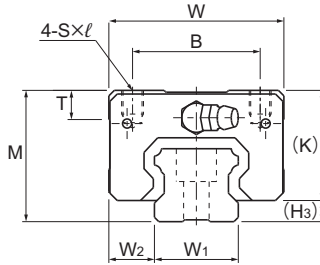

Model No.	Outer dimensions			LM block dimensions										Pilot hole for side nipple		
	Height	Width	Length	B	C	S×ℓ	L ₁	T	K	N	E	Grease nipple	e ₀	f ₀	D ₀	
	M	W	L													
SHS 15V SHS 15VM	24	34	64.4	26	26	M4×4	48	5.9	21	5.5	5.5	PB1021B	4	4	3	
SHS 15LV SHS 15LVM	24	34	79.4	26	34	M4×4	63	5.9	21	5.5	5.5	PB1021B	4	4	3	
SHS 20V SHS 20VM	30	44	79	32	36	M5×5	59	8	25.4	6.5	12	B-M6F	4.3	5.3	3	
SHS 20LV SHS 20LVM	30	44	98	32	50	M5×5	78	8	25.4	6.5	12	B-M6F	4.3	5.3	3	
SHS 25V SHS 25VM	36	48	92	35	35	M6×6.5	71	8	30.2	7.5	12	B-M6F	4.5	5.5	3	
SHS 25LV SHS 25LVM	36	48	109	35	50	M6×6.5	88	8	30.2	7.5	12	B-M6F	4.5	5.5	3	
SHS 30V SHS 30LV	42	60	106 131	40	40 60	M8×8	80 105	8	35	8	12	B-M6F	5.8	6	5.2	
SHS 35V SHS 35LV	48	70	122 152	50	50 72	M8×10	93 123	14.7	40.5	8	12	B-M6F	6.5	5.5	5.2	
SHS 45V SHS 45LV	60	86	140 174	60	60 80	M10×15	106 140	14.9	51.1	10.5	16	B-PT1/8	8	8	5.2	
SHS 55V SHS 55LV	70	100	171 213	75	75 95	M12×15	131 173	19.4	57.3	11	16	B-PT1/8	10	8	5.2	
SHS 65V SHS 65LV	90	126	221 272	76	70 120	M16×20	175 226	19.5	71	19	16	B-PT1/8	10	12	5.2	

Model number coding

SHS25 V 2 QZ KKHH C1 M +1240L P Z T M -II

Model number

Type of LM block

No. of LM blocks used on the same rail

With QZ Lubricator

Contamination protection accessory symbol (*1)

Radial clearance symbol (*2)
Normal (No symbol)
Light preload (C1)
Medium preload (C0)

Stainless steel LM block

LM rail length (in mm)

Accuracy symbol (*3)
Normal grade (No Symbol)
High accuracy grade (H)
Precision grade (P)
Super precision grade (SP)
Ultra precision grade (UP)

With steel tape

Stainless steel LM rail

Symbol for LM rail jointed use

Symbol for No. of rails used on the same plane (*4)

(*1) See contamination protection accessory on **A1-516**. (*2) See **A1-71**. (*3) See **A1-77**. (*4) See **A1-13**.

Note) This model number indicates that a single-rail unit constitutes one set. (i.e., required number of sets when 2 rails are used in parallel is 2 at a minimum.)

Those models equipped with QZ Lubricator cannot have a grease nipple. When desiring a grease nipple for a model attached with QZ, contact THK.

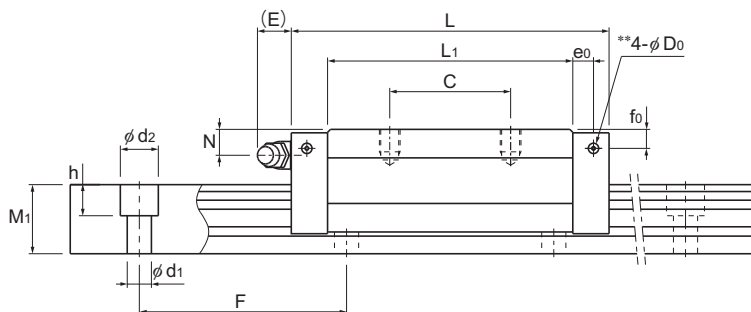

Unit: mm

H ₃	LM rail dimensions							Basic load rating		Static permissible moment kN*m*					Mass	
	W ₁ 0 -0.05	W ₂	M ₁	F	d ₁ × d ₂ × h	Length* Max	C kN	C ₀ kN	M _A		M _B		M _C	LM block kg	LM rail kg/m	
									1 block	Double blocks	1 block	Double blocks				
3	15	9.5	13	60	4.5 × 7.5 × 5.3	3000 (1240)	14.2	24.2	0.175	0.898	0.175	0.898	0.16	0.19	1.3	
3	15	9.5	13	60	4.5 × 7.5 × 5.3	3000 (1240)	17.2	31.9	0.296	1.43	0.296	1.43	0.212	0.22	1.3	
4.6	20	12	16.5	60	6 × 9.5 × 8.5	3000 (1480)	22.3	38.4	0.334	1.75	0.334	1.75	0.361	0.35	2.3	
4.6	20	12	16.5	60	6 × 9.5 × 8.5	3000 (1480)	28.1	50.3	0.568	2.8	0.568	2.8	0.473	0.46	2.3	
5.8	23	12.5	20	60	7 × 11 × 9	3000 (2020)	31.7	52.4	0.566	2.75	0.566	2.75	0.563	0.54	3.2	
5.8	23	12.5	20	60	7 × 11 × 9	3000 (2020)	36.8	64.7	0.848	3.98	0.848	3.98	0.696	0.67	3.2	
7	28	16	23	80	9 × 14 × 12	3000	44.8 54.2	66.6 88.8	0.786 1.36	4.08 6.6	0.786 1.36	4.08 6.6	0.865 1.15	0.94 1.16	4.5	
7.5	34	18	26	80	9 × 14 × 12	3000	62.3 72.9	96.6 127	1.38 2.34	6.76 10.9	1.38 2.34	6.76 10.9	1.53 2.01	1.4 1.84	6.2	
8.9	45	20.5	32	105	14 × 20 × 17	3090	82.8 100	126 166	2.05 3.46	10.1 16.3	2.05 3.46	10.1 16.3	2.68 3.53	2.54 3.19	10.4	
12.7	53	23.5	38	120	16 × 23 × 20	3060	128 161	197 259	3.96 6.68	19.3 31.1	3.96 6.68	19.3 31.1	4.9 6.44	4.05 5.23	14.5	
19	63	31.5	53	150	18 × 26 × 22	3000	205 253	320 408	8.26 13.3	40.4 62.6	8.26 13.3	40.4 62.6	9.4 11.9	8.41 10.7	23.7	

Note) The maximum length under "Length*" indicates the standard maximum length of an LM rail. (See **A1-102**.)

Static permissible moment* 1 block: the static permissible moment with one LM block

Double blocks: static permissible moment when two LM blocks are in close contact with each other

Total block length L

: The total block length L shown in the table is the length with the dust proof parts, code UU or SS.

If other contamination protection accessories or lubricant equipment are installed, the total block length will increase.

(See **A1-491** or **A1-512**)

** A pilot hole for side nipples, when a grease nipple for a model equipped with LaCS or QZ Lubricator is needed.

Pilot holes for side nipples are not drilled through for models other than those stated above.

For grease nipple mount machining, contact THK.

Models SHS-R, SHS-RM, SHS-LR and SHS-LRM

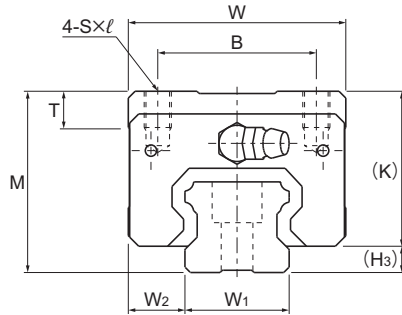

Model No.	Outer dimensions			LM block dimensions										Pilot hole for side nipple		
	Height	Width	Length	B	C	S×ℓ	L ₁	T	K	N	E	Grease nipple	e _o	f _o	D _o	
	M	W	L													
SHS 15R SHS 15RM	28	34	64.4	26	26	M4×5	48	5.9	25	9.5	5.5	PB1021B	4	8	3	
SHS 25R SHS 25RM	40	48	92	35	35	M6×8	71	8	34.2	11.5	12	B-M6F	6	9.5	3	
SHS 25LR SHS 25LRM	40	48	109	35	50	M6×8	88	8	34.2	11.5	12	B-M6F	6	9.5	3	
SHS 30R SHS 30LR	45	60	106 131	40	40 60	M8×10	80 105	8	38	11	12	B-M6F	5.8	9	5.2	
SHS 35R SHS 35LR	55	70	122 152	50	50 72	M8×12	93 123	14.7	47.5	15	12	B-M6F	6.5	12.5	5.2	
SHS 45R SHS 45LR	70	86	140 174	60	60 80	M10×17	106 140	14.9	61.1	20.5	16	B-PT1/8	8	18	5.2	
SHS 55R SHS 55LR	80	100	171 213	75	75 95	M12×18	131 173	19.4	67.3	21	16	B-PT1/8	10	18	5.2	

Model number coding

SHS25	LR	2	QZ	KKHH	C0	M	+1240L	P	T	M	-II								
Model number	Type of LM block	No. of LM blocks used on the same rail	With QZ Lubricator	Contamination protection accessory symbol (*1)	Radial clearance symbol (*2)	Normal (No symbol)	Light preload (C1)	Medium preload (C0)	Stainless steel LM block	LM rail length (in mm)	Accuracy symbol (*3)	Normal grade (No Symbol)	High accuracy grade (H)	Precision grade (P)	Super precision grade (SP)	Ultra precision grade (UP)	Stainless steel LM rail	Symbol for LM rail jointed use	No. of rails used on the same plane (*4)

(*1) See contamination protection accessory on **A1-516**. (*2) See **A1-71**. (*3) See **A1-77**. (*4) See **A1-13**.

Note) This model number indicates that a single-rail unit constitutes one set. (i.e., required number of sets when 2 rails are used in parallel is 2 at a minimum.)
Those models equipped with QZ Lubricator cannot have a grease nipple. When desiring a grease nipple for a model attached with QZ, contact THK.

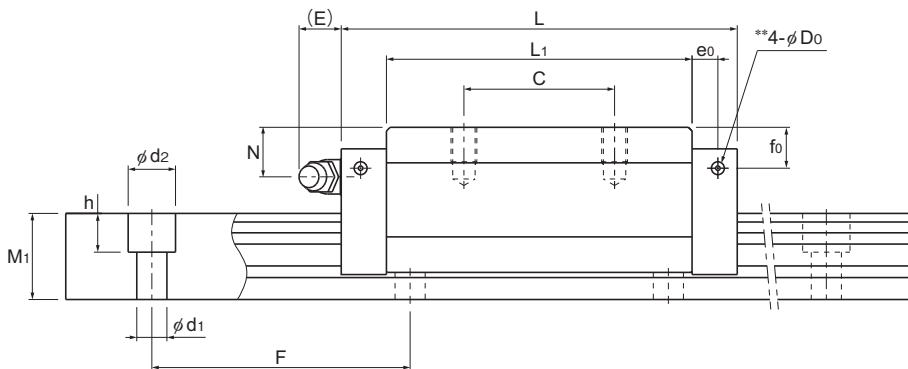

Unit: mm

H _s	LM rail dimensions							Basic load rating		Static permissible moment kN·m*					Mass	
	W ₁ 0 -0.05	W ₂	M ₁	F	d ₁ × d ₂ × h	Length* Max	C	C ₀	M _A		M _B		M _C	LM block kg	LM rail kg/m	
									1 block	Double blocks	1 block	Double blocks	1 block			
3	15	9.5	13	60	4.5 × 7.5 × 5.3	3000 (1240)	14.2	24.2	0.175	0.898	0.175	0.898	0.16	0.22	1.3	
5.8	23	12.5	20	60	7 × 11 × 9	3000 (2020)	31.7	52.4	0.566	2.75	0.566	2.75	0.563	0.66	3.2	
5.8	23	12.5	20	60	7 × 11 × 9	3000 (2020)	36.8	64.7	0.848	3.98	0.848	3.98	0.696	0.8	3.2	
7	28	16	23	80	9 × 14 × 12	3000	44.8 54.2	66.6 88.8	0.786 1.36	4.08 6.6	0.786 1.36	4.08 6.6	0.865 1.15	1.04 1.36	4.5	
7.5	34	18	26	80	9 × 14 × 12	3000	62.3 72.9	96.6 127	1.38 2.34	6.76 10.9	1.38 2.34	6.76 10.9	1.53 2.01	1.8 2.34	6.2	
8.9	45	20.5	32	105	14 × 20 × 17	3090	82.8 100	126 166	2.05 3.46	10.1 16.3	2.05 3.46	10.1 16.3	2.68 3.53	3.24 4.19	10.4	
12.7	53	23.5	38	120	16 × 23 × 20	3060	128 161	197 259	3.96 6.68	19.3 31.1	3.96 6.68	19.3 31.1	4.9 6.44	5.05 6.57	14.5	

Note) The maximum length under "Length*" indicates the standard maximum length of an LM rail. (See **A1-102**)

Static permissible moment* 1 block: the static permissible moment with one LM block

Double blocks: static permissible moment when two LM blocks are in close contact with each other

: The total block length L shown in the table is the length with the dust proof parts, code UU or SS.

If other contamination protection accessories or lubricant equipment are installed, the total block length will increase.

(See **A1-491** or **A1-512**)

** A pilot hole for side nipples, when a grease nipple for a model equipped with LaCS or QZ Lubricator is needed.

Pilot holes for side nipples are not drilled through for models other than those stated above.

For grease nipple mount machining, contact THK.

Standard Length and Maximum Length of the LM Rail

Table1 shows the standard and maximum lengths of the SHS model rail. If a rail length longer than the listed max length is required, rails may be jointed to meet the overall length. Contact THK for details. For special rail lengths, it is recommended to use a value corresponding to the G,g dimension from the table. As the G,g dimension increases, this portion becomes less stable, and the accuracy performance is severely impacted.

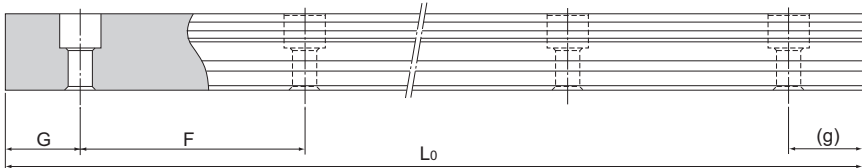

Table1 Standard Length and Maximum Length of the LM Rail for Model SHS

Unit: mm

Model No.	SHS 15	SHS 20	SHS 25	SHS 30	SHS 35	SHS 45	SHS 55	SHS 65
LM rail standard length (L ₀)	160	220	220	280	280	570	780	1270
	220	280	280	360	360	675	900	1570
	280	340	340	440	440	780	1020	2020
	340	400	400	520	520	885	1140	2620
	400	460	460	600	600	990	1260	
	460	520	520	680	680	1095	1380	
	520	580	580	760	760	1200	1500	
	580	640	640	840	840	1305	1620	
	640	700	700	920	920	1410	1740	
	700	760	760	1000	1000	1515	1860	
	760	820	820	1080	1080	1620	1980	
	820	940	940	1160	1160	1725	2100	
	940	1000	1000	1240	1240	1830	2220	
	1000	1060	1060	1320	1320	1935	2340	
	1060	1120	1120	1400	1400	2040	2460	
	1120	1180	1180	1480	1480	2145	2580	
	1180	1240	1240	1560	1560	2250	2700	
	1240	1360	1300	1640	1640	2355	2820	
	1360	1480	1360	1720	1720	2460	2940	
	1480	1600	1420	1800	1800	2565	3060	
1600	1720	1480	1880	1880	2670			
	1840	1540	1960	1960	2775			
	1960	1600	2040	2040	2880			
	2080	1720	2200	2200	2985			
	2200	1840	2360	2360	3090			
		1960	2520	2520				
		2080	2680	2680				
		2200	2840	2840				
		2320	3000	3000				
		2440						
Standard pitch F	60	60	60	80	80	105	120	150
G,g	20	20	20	20	20	22.5	30	35
Max length	3000 (1240)	3000 (1480)	3000 (2020)	3000	3000	3090	3060	3000

Note1) The maximum length varies with accuracy grades. Contact THK for details.

Note2) If jointed rails are not allowed and a greater length than the maximum values above is required, contact THK.

Note3) The figures in the parentheses indicate the maximum lengths of stainless steel models.

Tapped-hole LM Rail Type of Model SHS

SHS model rails also include a type where the LM rail is tapped from the bottom. This type is useful when mounting from the bottom of the base and when increased contamination protection is desired.

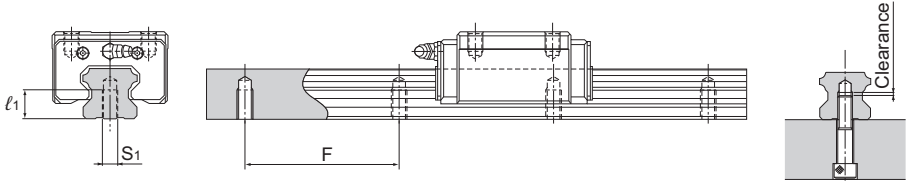

LM Guide

- (1) Determine the bolt length so that a clearance of 2 to 5 mm is secured between the bolt end and the bottom of the tap (effective tap depth). (See figure above.)
- (2) For standard pitches of the taps, see Table1 on **A1-102**.

Table2 Dimensions of the LM Rail Tap

Unit: mm

Model No.	S ₁	Effective tap depth l_1
SHS 15	M5	8
SHS 20	M6	10
SHS 25	M6	12
SHS 30	M8	15
SHS 35	M8	17
SHS 45	M12	20
SHS 55	M14	24
SHS 65	M20	30

Model number coding

SHS35 LC2UU +1000LH K

K
Symbol for
tapped-hole LM rail type