

Ball rail systems

ball runner blocks, ball guide rails, accessories

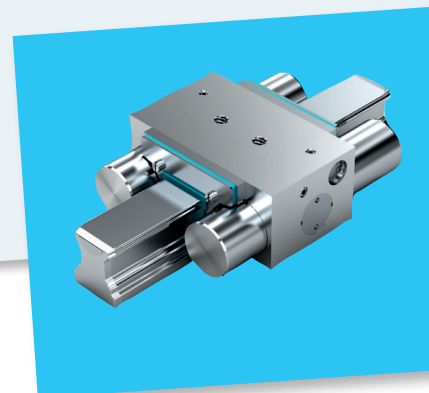
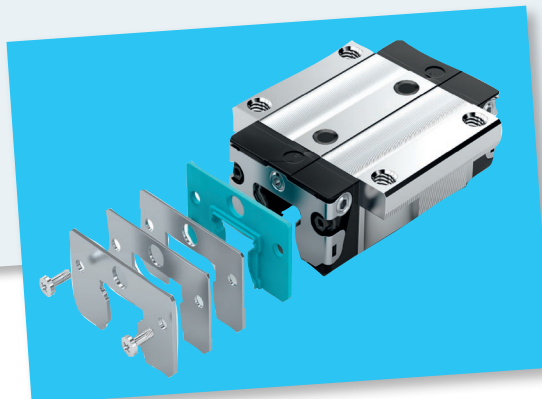
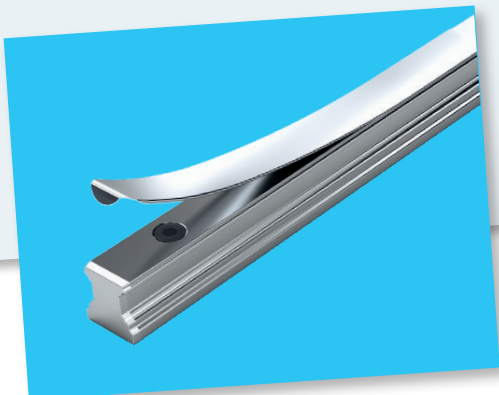
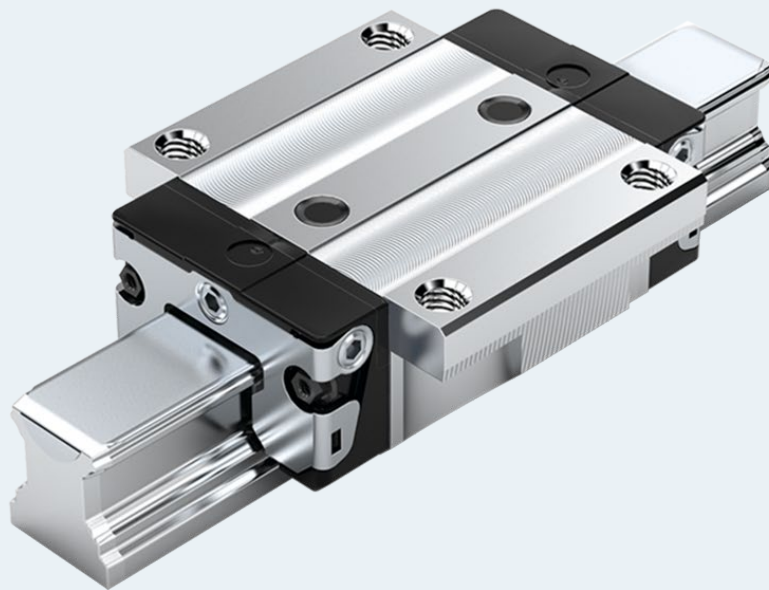

General product information	4	High-speed ball runner blocks BSHP made of steel	84
New features at a glance	4	Product description	84
Product description	6	FNS, FLS, SNS, SLS	85
Notes	8		
Selection of a linear guide according to DIN 637	10	Super ball runner blocks made of steel	86
Product overview ball runner blocks		Product description	86
with load capacities and load moments	12	FKS – Flange, short, standard height	88
Product overview ball guide rails with rail lengths	16	SKS – Slimline, short, standard height	90
General technical data and calculations	18		
Format and version	26	Aluminum ball runner blocks BSHP	92
System preload	30	Product description	92
Accuracy classes	33	FNS – Flange, normal, standard height, R1631 ... 2.	94
Ball chain	35	SNS – Slimline, normal, standard height, R1632 ... 2.	96
Seals	35		
Materials	36	Ball runner blocks BSHP Resist NR	98
		Product description	98
		FNS, FLS, FKS, SNS, SLS, SKS	99
Product description High-precision ball runner blocks BSHP made of steel	38	Ball runner blocks BSHP Resist NR	100
Product description	38	Product description	100
Comparison	39	FNS, FLS, FKS, SNS, SLS, SKS	102
Application examples	45		
		Ball runner blocks BSHP Resist NR	104
Standard ball runner blocks BSHP made of steel	46	Product description	104
Overview	46	FNS, FLS, SNS, SLS, SNH, SLH, FNN, FKN, SNN, SKN, FKS, SKS	106
Ordering example	47		
FNS – Flange, normal, standard height	48	Standard ball guide rails made of steel	108
FLS – Flange, long, standard height	50	Product description	108
FKS – Flange, short, standard height	52	Ordering guide rails in the recommended rail lengths	109
SNS – Slimline, normal, standard height	54	SNS/SNO with cover strip and strip clamps	110
SLS – Slimline, long, standard height	56	SNS/SNO with cover strip and protective caps	112
SKS – Slimline, short, standard height	58	SNS/SNO with plastic caps	114
SNH – Slimline, normal, high	60	SNS with caps made of steel	116
SLH – Slimline, long, high	62	SNS for bolting from below	118
FNN – Flange, normal, low	64		
FKN – Flange, short, low	66	Standard ball guide rails Resist NR II	120
SNN – Slimline, normal, low	68	Product description	120
SKN – Slimline, short, low	70		
		Standard ball guide rails Resist CR	122
Heavy-duty ball runner blocks BSHP made of steel	72	Product description	122
FNS – Flange, normal, standard height	72		
FLS – Flange, long, standard height	74	Standard ball guide rails with temperature control	124
SNS – Slimline, normal, standard height	76		
SLS – Slimline, long, standard height	78		
SNH – Slimline, normal, high	80		
SLH – Slimline, long, high	82		

<hr/>			
Wide ball rail systems BSHP made of steel and Resist CR	126	Product description pneumatic clamping units	188
Product description	126	Pneumatic clamping units MK	190
BNS – Wide, normal, standard height	128	Pneumatic clamping units MKS	192
BNS – Wide, normal, standard height	130	Pneumatic clamping units LCP	194
CNS – Compact, normal, standard height	132	Pneumatic clamping units LCPS	196
Ordering guide rails in the recommended rail lengths	135	Manual clamping units, product description	198
BNS with plastic caps	136	Manual clamping units HK	199
BNS with caps made of steel	138	Spacer plate	201
BNS for bolting from below	139	Safety instructions clamping and braking units	202
<hr/>			
Accessories for ball runner blocks	140	Instructions for mounting	204
Product description	140	General instructions for mounting	204
Cover plate wiper	141	Fastener	205
Front seal	142	Installation tolerances	215
FKM seal	143	Composite ball guide rails	218
Seal kit	144		
Lubrication adapter	145	Lubrication	221
Lubrication plate	146	Notes on lubrication	221
Lubrication plate G 1/8	147	Lubrication	222
Transport lock	148	Maintenance	236
Front lube units	150		
Bellows	154	Further information	239
Lube nipple, lube fittings, extensions	158		
<hr/>			
Accessories for ball guide rails	162		
Product description	162		
Cover strip	163		
Caps	167		
Mounting runner block	168		
V-guide	170		
Cardboard box opener	171		
<hr/>			
Clamping and braking units	172		
Product description hydraulic clamping and braking units	172		
Hydraulic clamping and braking units, KBH, FLS	174		
Hydraulic clamping and braking units, KBH, SLS	175		
Hydraulic clamping units product description	176		
Technical data and calculations	177		
Hydraulic clamping units KWH, FLS	178		
Hydraulic clamping units KWH, SLS	179		
Hydraulic clamping units KWH, SLH	180		
Pneumatic clamping and braking units, product description	182		
Pneumatic clamping and braking units MBPS	184		
Pneumatic clamping and braking units UBPS	186		

New features at a glance

Runner block and guide rail configurator

With the new configurators, Bosch Rexroth accelerates the selection and configuration of ball runner blocks and ball guide rails. A built-in plausibility check monitors each decision in real time to ensure that the individual configuration can be implemented. Then the selected components can be ordered directly from the Bosch Rexroth eShop.

[Link to the runner block configurator](#)

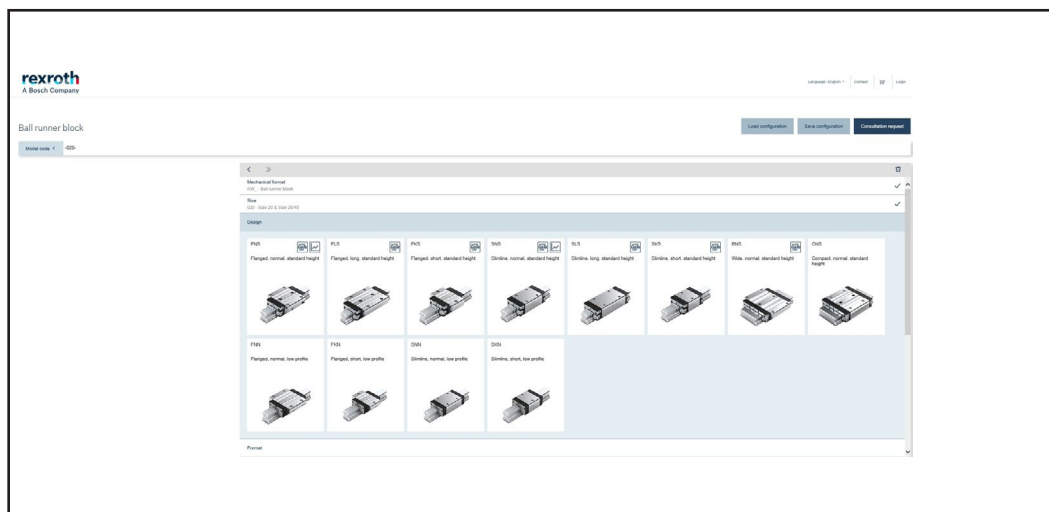

[Link to the runner block configurator](#)

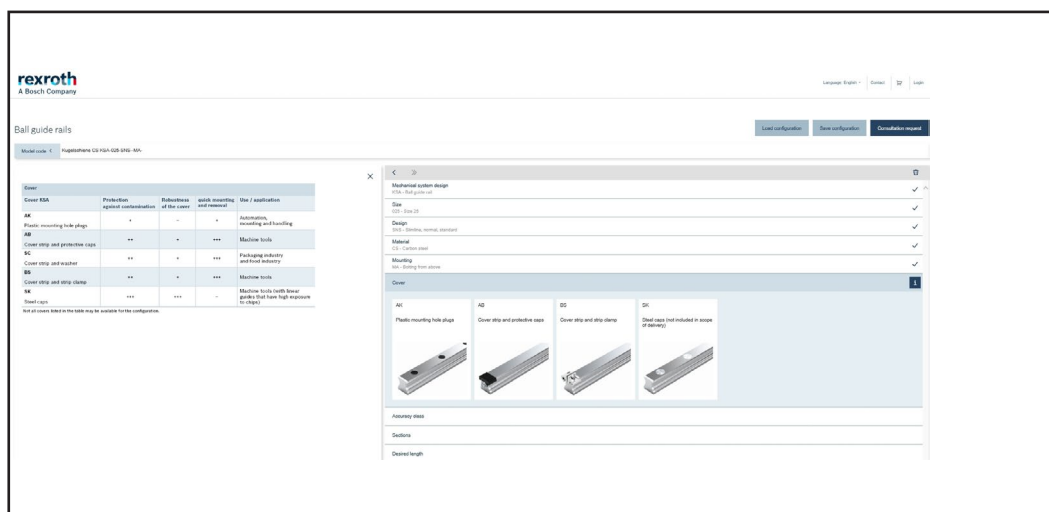

Temperature-controlled rail

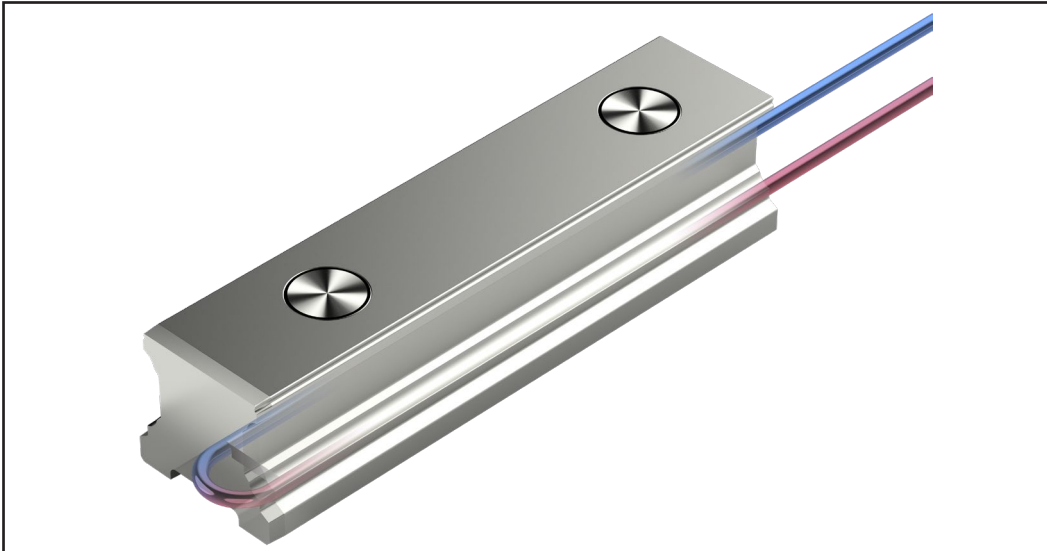

Extension of relubrication intervals for grease lubrication

The latest investigations in the Bosch Rexroth testing prove that under certain operating conditions, significantly longer relubrication intervals are possible with grease lubrication. If small loads, normal ambient temperatures and medium to high travel speeds are present, up to 20,000 km can be realized without relubrication in ball rail systems. This enormous increase has been made possible by continuous improvements in the manufacturing processes for runner blocks and guide rails, which have resulted in better surfaces and higher geometrical dimensional accuracy of the running tracks.

Mounting runner block

Mounting runner block for high-precision parallel alignment and joint alignment of multi-piece ball guide rails.

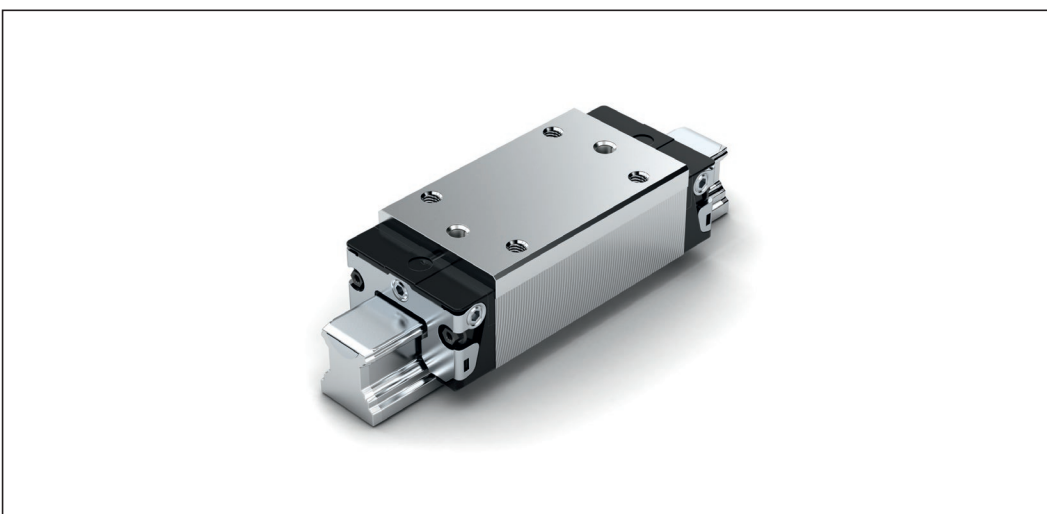

Product description

Characteristic features

Complete guide units can also be designed by combining interchangeable elements from stock

Rexroth manufactures ball guide rails and ball runner blocks especially for the ball raceway sector with such high precision that each individual component element is fully interchangeable. As a result, any combination is possible within each accuracy class. This enables globally unique, premium logistics. Each element can be individually planned and separately stocked.

On ball guide rails, both sides can be used as reference edges.

Highlights

- ▶ The same high load capacities in all four main directions of loading
- ▶ Minimal noise level and optimum travel behavior
- ▶ Excellent dynamic characteristics:
 - Travel speed: v_{\max} up to 10 m/s
 - Acceleration: $a_{\max} = 500 \text{ m/s}^2$
- ▶ Long-term lubrication is possible over several years
- ▶ Minimum quantity lubrication system with integrated reservoir for oil lubrication¹⁾
- ▶ Lube fittings with metal threads on all sides¹⁾
- ▶ Limitless interchangeability as all ball guide rail versions can be combined at will with all ball runner block versions
- ▶ Maximum system rigidity due to preloaded O-arrangement
- ▶ Maximum installation error compensation with super ball runner blocks
- ▶ 60% less weight with aluminum ball runner blocks (compared to steel ball runner blocks)

Further highlights

- ▶ Interchangeability with roller rail system
- ▶ Optional integrated, inductive and wear-free measuring system
- ▶ Wide range of accessories
- ▶ Attachments on the ball runner block can be bolted from above and below¹⁾
- ▶ Improved rigidity under lift-off and side loading conditions due to two additional mounting screw bores at the center of the ball runner block¹⁾
- ▶ End-face fastening thread for all attachments
- ▶ High rigidity in all directions of loading – permits applications with just one runner block per rail
- ▶ Integrated all-round sealing
- ▶ High torque load capacity
- ▶ Optimized entry-zone geometry and high number of balls minimize variation in elastic deflection
- ▶ Quiet, smooth running thanks to optimally designed ball and ball chain return and guideway
- ▶ Different preload classes

Corrosion protection (optional)¹⁾

- ▶ Resist NR: Ball runner block body made of corrosion-resistant steel as per DIN EN 10088
- ▶ Resist NR II: Ball runner block body and ball guide rail as well as all steel parts made of corrosion-resistant steel in accordance with DIN EN 10088
- ▶ Resist CR: Ball runner block body or ball guide rail made of steel with corrosion-resistant coating, matte-silver finish, hard chrome plated

1) Type-dependent

Ball chain (optional)

- ▶ Optimized noise level



Proven cover strip for the ball guide rail fastening bores

- ▶ One cover for all bore holes saves time and costs
- ▶ Made of corrosion-resistant spring steel DIN EN 10088
- ▶ Easy and safe during mounting
- ▶ Clip on and secure

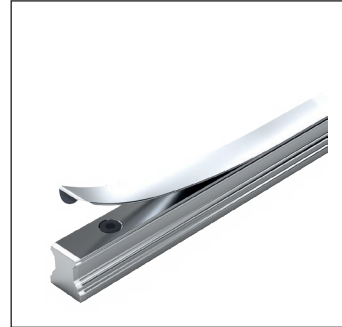

Separate catalogs are available for other products in the field of ball rail systems:



Integrated measuring system
IMS for ball and roller rail
systems



Integrated measuring
system IMScompact for
BSHP ball rail systems



Miniature ball guide rail
systems



Ball rail systems NFRG for
use in the packaging
industry and food industry
areas.



Cam roller guides

Notes

General notes

- ▶ Combinations of different accuracy classes
Combining ball guide rails and ball runner blocks of different accuracy classes results in different tolerances for the dimensions H and A3. See "Accuracy classes and their tolerances."

Intended use

- ▶ The ball rail systems are linear guideways capable of absorbing forces from all transverse directions and moments about all axes. The ball rail system is intended exclusively for guiding and positioning tasks when installed in a machine.
- ▶ The product is intended exclusively for professional use and not for private use.
- ▶ Use for the intended purpose also includes the requirement that users must have read and understood the related documentation completely, in particular the "Safety instructions".

Misuse

Use of the product in any other way than as described under "Intended use" is considered to be misuse and is therefore not permitted. If unsuitable products are installed or used in safety-critical applications, this may lead to uncontrolled operating statuses in the application which can cause personal injury and/or damage to property.

The product may only be used in safety-critical applications if this use has been expressly specified and permitted in the product documentation.

Bosch Rexroth AG will not accept any liability for injury or damage caused by misuse of the product. The risks associated with any misuse of the product shall be borne by the user alone.

Misuse of the product includes:

- ▶ The transport of persons

General safety instructions

- ▶ The safety rules and regulations of the country in which the product is used must be observed.
- ▶ All current and applicable accident prevention and environmental regulations must be adhered to.
- ▶ The product may only be used when it is in technically perfect condition.
- ▶ The technical data and environmental conditions stated in the product documentation must be complied with.
- ▶ The product must not be put into service until it has been verified that the final product (for example a machine or system) into which the product has been installed complies with the country-specific requirements, safety regulations and standards for the application.
- ▶ Rexroth ball rail systems may not be used in zones with potentially explosive atmospheres as defined in ATEX directive 94/9/EC.
- ▶ Rexroth ball rail systems must never be altered or modified. The user may only perform the work described in the "Quick User Guide" or the "Mounting instructions for ball rail systems".
- ▶ The product is never allowed to be disassembled.
- ▶ At high travel speeds a certain amount of noise is caused by the product. If necessary, appropriate measures should be taken to protect hearing.
- ▶ The special safety requirements for specific sectors (e.g. crane construction, theaters, food technology) set forth in laws, directives and standards must be complied with.
- ▶ In all cases, the provisions of the following standard should be noted and followed. DIN 637, Safety regulations for dimensioning and operation of Profiled Rail Systems with recirculating rolling elements.

Directives and standards

Rexroth ball rail systems BSHP are designed for reliability and high precision in dynamic, linear applications. The machine tool industry and other sectors must observe a series of standards and directives. These requirements can vary significantly worldwide. It is therefore essential to understand the legislation and standards that apply in each particular region.

DIN EN ISO 12100

This standard describes the safety of machinery – general principles for design, risk assessment and risk reduction. It gives a general overview and contains a guide to the major developments governing machines and their intended use.

Directive 2006/42/EC

The European Machinery Directive describes the basic safety and health requirements for the structural design and manufacture of machinery. The manufacturer of a machine or his authorized representative has a duty to ensure that a risk assessment has been performed in order to determine the health and safety requirements which have to be fulfilled for that machine. The machine must be designed and built taking into account the results of the risk assessment.

Directive 2001/95/EC

This directive covers general safety requirements for any product placed on the market and intended for consumers, or likely to be used by consumers under reasonably foreseeable conditions, including products that are made available to consumers in the context of service provision for use by them

Directive 1999/34/EC

This directive concerns the liability for defective products and applies to industrially manufactured movable objects, irrespective of whether or not they have been incorporated into another movable or immovable object.

REGULATION (EC) No. 1907/2006 (REACH)

This directive describes the restrictions on the marketing and use of certain dangerous substances and preparations. "Substances" means chemical elements and their compounds as they occur in the natural state or as produced by industry. "Preparations" means mixtures or solutions composed of two or more substances.

Selection of a linear guide according to DIN 637

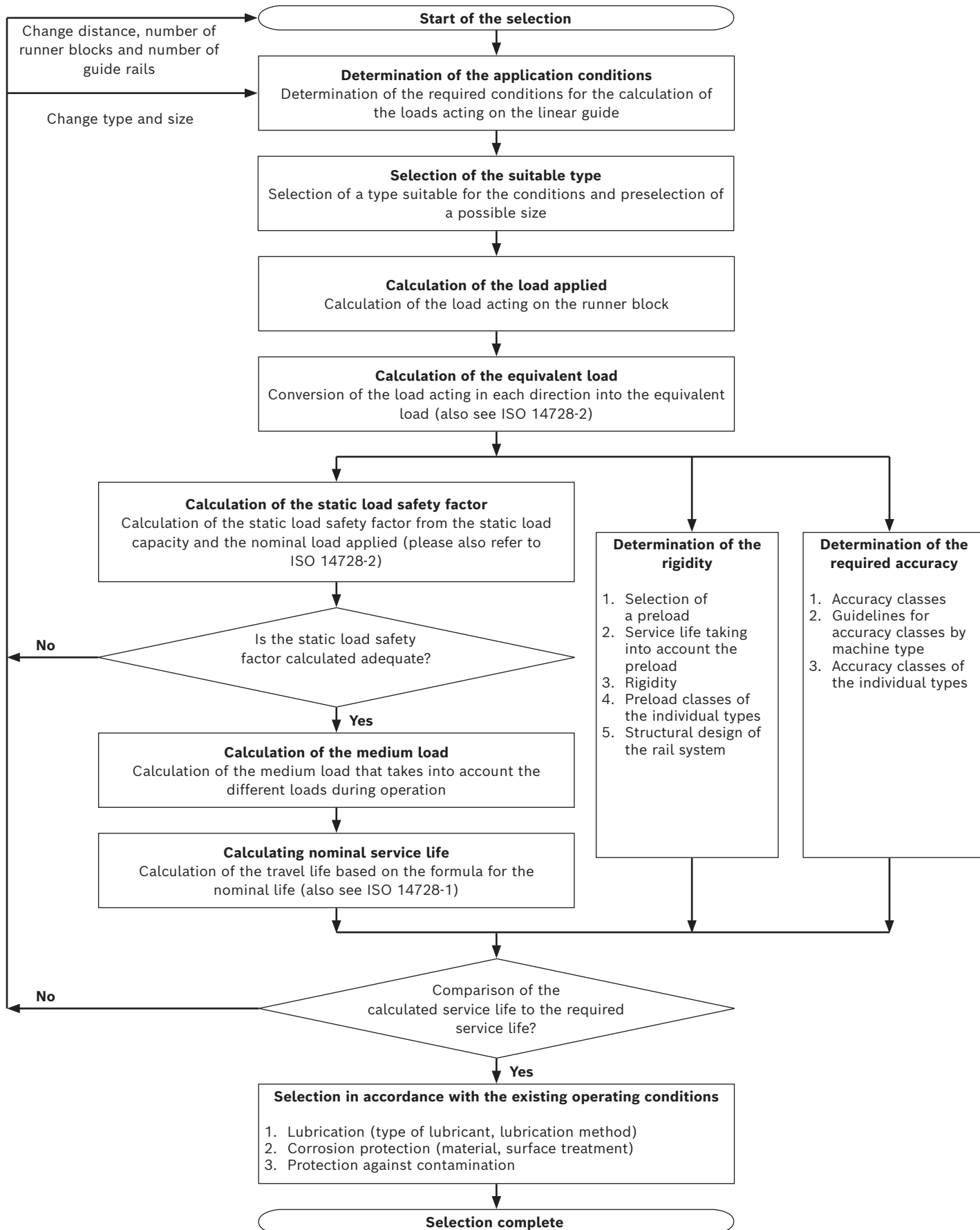

Product overview Ball runner blocks with load capacities and load moments

Ball runner blocks		Page	Size	15	20	25	30	35	45	55	65			
				Load capacities (N) and load moments (Nm)										
Standard, heavy-duty, ball runner blocks⁷⁾ made of steel³⁾ Resist NR⁴⁾ Resist CR⁶⁾	 FNS R1651³⁾⁶⁾ R2001⁴⁾	48 ³⁾	106 ⁶⁾	C ¹⁾	9860	23400	28600	36500	51800	86400	109000	172000		
				C ²⁾	8850	22200	26700	34800	49400	82400	-	-		
		 SNS R1622³⁾⁶⁾ R2011⁴⁾	54 ³⁾	106 ⁶⁾	C ₀ ¹⁾	12700	29800	35900	48100	80900	132000	174000	280000	
					C ₀ ²⁾	10800	27700	32300	44700	75200	123000	-	-	
			 SNH R1621³⁾⁶⁾	60 ³⁾	106 ⁶⁾	M _t ¹⁾	95	300	410	630	1110	2330	3480	6810
						M _t ²⁾	85	280	380	600	1060	2220	-	-
	M _{t0} ¹⁾					120	380	510	830	1740	3560	5550	11100	
	M _{t0} ²⁾					100	350	460	780	1620	3320	-	-	
	 SLH R1624³⁾⁶⁾	62 ³⁾	106 ⁶⁾	M _L ¹⁾	68	200	290	440	720	1540	2320	4560		
				M _L ²⁾	62	190	270	420	700	1480	-	-		
				M _{L0} ¹⁾	87	260	360	580	1130	2350	3690	7400		
				M _{L0} ²⁾	76	240	330	540	1060	2210	-	-		
Standard ball runner blocks⁷⁾ made of steel³⁾ Resist NR⁴⁾ Resist CR⁶⁾	 FLS R1653³⁾⁶⁾ R2002⁴⁾	50 ³⁾	106 ⁶⁾	C ¹⁾	12800	29600	37300	46000	66700	111000	139000	223000		
				C ²⁾	11500	28200	34800	43800	63600	106000	-	-		
		 SLS R1623³⁾⁶⁾ R2012⁴⁾	56 ³⁾	106 ⁶⁾	C ₀ ¹⁾	18400	41800	52500	66900	116000	190000	245000	404000	
					C ₀ ²⁾	15600	38800	47300	62200	108000	177000	-	-	
			 SLH R1624³⁾⁶⁾	62 ³⁾	106 ⁶⁾	M _t ¹⁾	120	380	530	800	1440	3010	4410	8810
						M _t ²⁾	110	360	500	760	1370	2870	-	-
	M _{t0} ¹⁾					180	540	750	1160	2500	5120	7780	16000	
	M _{t0} ²⁾					150	500	670	1080	2320	4770	-	-	
	Standard ball runner blocks⁷⁾ made of steel³⁾ Resist NR⁴⁾ Resist CR⁶⁾	 FKS R1665³⁾ R2000⁴⁾	52 ³⁾	106	C ¹⁾	6720	15400	19800	25600	36600	-	-	-	
					C ²⁾	6030	14700	18500	24400	34900	-	-	-	
			 SKS R1666³⁾ R2010⁴⁾	58 ³⁾	106	C ₀ ¹⁾	7340	16500	21200	28900	49300	-	-	-
						C ₀ ²⁾	6230	15300	19100	26900	45800	-	-	-
 SKS R1666³⁾ R2010⁴⁾				99 ⁴⁾	106	M _t ¹⁾	65	200	280	440	790	-	-	-
						M _t ²⁾	58	190	260	420	750	-	-	-
		M _{t0} ¹⁾				71	210	300	500	1060	-	-	-	
		M _{t0} ²⁾				60	200	270	470	980	-	-	-	
 FNN R1693³⁾⁶⁾⁸⁾ SNN R1694³⁾⁶⁾⁸⁾		64 ³⁾	106 ⁶⁾	M _L ¹⁾	29	83	130	200	340	-	-	-		
				M _L ²⁾	27	81	120	200	330	-	-	-		
		 FKN R1663³⁾⁶⁾⁸⁾ SKN R1664³⁾⁶⁾⁸⁾	70 ³⁾	106 ⁶⁾	M _{L0} ¹⁾	32	89	140	230	460	-	-	-	
					M _{L0} ²⁾	28	84	130	220	430	-	-	-	
	 FNN R1693³⁾⁶⁾⁸⁾				64 ³⁾	106 ⁶⁾	C ¹⁾	-	14500	28600	-	-	-	-
							C ₀ ¹⁾	-	24400	35900	-	-	-	-
 SNN R1694³⁾⁶⁾⁸⁾	68 ³⁾	106 ⁶⁾	M _t ¹⁾	-	190	410	-	-	-	-	-			
			M _{t0} ¹⁾	-	310	510	-	-	-	-	-			
			M _L ¹⁾	-	100	290	-	-	-	-	-			
			M _{L0} ¹⁾	-	165	360	-	-	-	-	-			
Super ball runner blocks made of steel³⁾ Resist CR⁶⁾	 FKS 1661³⁾⁶⁾	88 ³⁾	107 ⁶⁾	C ¹⁾	3900	10100	11400	15800	21100	-	-	-		
				F _{max} ¹⁾	1500	3900	4400	6100	8100	-	-	-		
	 SKS 1662³⁾⁶⁾	90 ³⁾	107 ⁶⁾	M _t ¹⁾	39	130	170	270	450	-	-	-		
				M _{tmax} ¹⁾	15	50	65	105	175	-	-	-		







Ball runner blocks		Page	Size	15	20	25	30	35	45	55	65	
				Load capacities (N) and load moments (Nm)								
High-speed ball runner blocks made of steel ⁷⁾		FNS R2001 ... 9.	85	C ¹⁾	6880	16300	20000	25500	36200	60300	-	-
				C ₀ ¹⁾	8860	20800	25100	33500	56500	92100	-	-
		SNS R2011 ... 9.	85	M _t ¹⁾	66	210	280	440	780	1630	-	-
				M _{t0} ¹⁾	85	270	360	580	1210	2490	-	-
				M _L ¹⁾	47	140	200	310	510	1070	-	-
				M _{L0} ¹⁾	61	180	250	400	790	1640	-	-
	FLS R2002 ... 9.	85	C ¹⁾	8930	20700	26000	32100	46600	77700	-	223000	
			C ₀ ¹⁾	12800	29200	36600	46700	81100	132000	-	404000	
		SLS R2012... 9.	85	M _t ¹⁾	86	260	370	560	1000	2100	-	8810
				M _{t0} ¹⁾	120	370	520	810	1740	3570	-	16000
				M _L ¹⁾	85	240	370	520	900	1910	-	8160
				M _{L0} ¹⁾	120	340	520	750	1560	3250	-	14800
Aluminum ball runner blocks ⁷⁾		FNS R1631	94	C ¹⁾	9860	23400	28600	36500	51800	-	-	-
			C ²⁾	8850	22200	26700	34800	49400	-	-	-	
		SNS R1632	96	F _{max} ^{1) 2)}	3000	7200	8800	12200	16200	-	-	-
				M _t ¹⁾	95	300	410	630	1110	-	-	-
				M _t ²⁾	85	280	380	600	1060	-	-	-
				M _{tmax} ^{1) 2)}	29	92	125	210	345	-	-	-
				M _L ¹⁾	68	200	290	440	720	-	-	-
				M _L ²⁾	62	190	270	420	700	-	-	-
	M _{Lmax} ^{1) 2)}	16	50	70	110	170	-	-	-			

The determination of the dynamic load capacities and load moments is based on a 100000 m stroke according to DIN ISO14728-1. However, the values are often based on only 50000 m. For comparison: Multiply the values **C**, **M_t** and **M_L** by 1.26 according to the table.

- 1) Ball runner block **without** ball chain.
- 2) Ball runner block **with** ball chain.
- 3) Steel: All steel parts made of carbon steel.
- 4) Resist NR size 15 - 35: Ball runner block body made of corrosion-resistant steel as per DIN EN 10088.
- 5) Resist NR II: All steel components are made from corrosion-resistant steel in accordance with DIN EN 10088.
- 6) Resist CR: Steel ball runner block body with corrosion-resistant coating, matte-silver finish, hard chrome plated.
- 7) Ball runner block BSHP
- 8) Ball runner block BSHP size 25 only

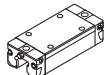
For short product names of the types, see the product description

Product overview Ball runner blocks with load capacities and load moments

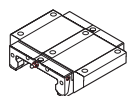
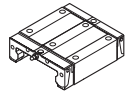
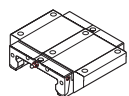
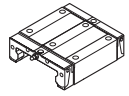
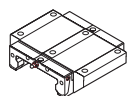
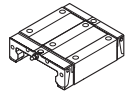
Ball runner blocks		Page	Size	Load capacities (N) and load moments (Nm)												
				15	20 20/40	25 25/70	30	35 35/90	45	55	65					
Ball runner blocks Resist NR II ⁽⁵⁾⁷⁾	 FNS R2001 ... 0.	102	C	1)	5100	12300	15000	20800	27600	-	-	-				
				2)	4700	11400	14000	19300	27600	-	-	-				
		 SNS R2011 ... 0.	103	C ₀	1)	9300	16900	21000	28700	37500	-	-	-			
					2)	8400	15000	18900	25800	37500	-	-	-			
			 FLS R2002 ... 0.	102	C	1)	8500	16000	20000	26300	36500	-	-	-		
						2)	7600	15200	18100	25000	34800	-	-	-		
	 SLS R2012 ... 0.			103	C ₀	1)	14000	24400	31600	40100	56200	-	-	-		
						2)	12100	22500	27400	37300	52500	-	-	-		
		 FLS R2000 ... 0.		102	M _t	1)	63	205	270	460	760	-	-	-		
						2)	58	190	250	425	760	-	-	-		
			 SKS R2010 ... 0.	103	M _{t0}	1)	90	215	295	500	805	-	-	-		
						2)	81	190	265	450	805	-	-	-		
	 FLS R2000 ... 0.			102	M _L	1)	34	110	150	245	375	-	-	-		
						2)	31	100	140	225	375	-	-	-		
		 SKS R2010 ... 0.		103	M _{L0}	1)	49	115	165	265	390	-	-	-		
						2)	44	100	150	240	390	-	-	-		
			Wide ball runner blocks made of steel ⁽³⁾⁷⁾ Resist CR ⁽⁶⁾⁷⁾	 BNS R1671 ⁽³⁾⁶⁾	126 ³⁾	126 ⁶⁾	C	1)	-	14900	36200	-	70700	-	-	-
								2)	-	13700	33700	-	-	-	-	-
 CNS R1672 ⁽³⁾⁶⁾	130 ³⁾				130 ⁶⁾	C ₀	1)	-	20600	50200	-	126000	-	-	-	
							2)	-	18200	45200	-	-	-	-	-	-
	 BNS R1671 ⁽³⁾⁶⁾	126 ³⁾		126 ⁶⁾	M _t	1)	-	340	1350	-	3500	-	-	-		
						2)	-	310	1260	-	-	-	-	-	-	
 CNS R1672 ⁽³⁾⁶⁾		130 ³⁾		130 ⁶⁾	M _{t0}	1)	-	470	1870	-	6240	-	-	-		
						2)	-	410	1680	-	-	-	-	-	-	
	 BNS R1671 ⁽³⁾⁶⁾	126 ³⁾		126 ⁶⁾	M _L	1)	-	140	490	-	1470	-	-	-		
						2)	-	130	460	-	-	-	-	-	-	
 CNS R1672 ⁽³⁾⁶⁾		130 ³⁾		130 ⁶⁾	M _{L0}	1)	-	190	680	-	2620	-	-	-		
						2)	-	170	620	-	-	-	-	-	-	

The determination of the dynamic load capacities and load moments is based on a 100000 m stroke according to DIN ISO14728-1. However, the values are often based on only 50000 m. For comparison: Multiply the values **C**, **M_t** and **M_L** by 1.26 according to the table.

- 1) Ball runner block **without** ball chain.
- 2) Ball runner block **with** ball chain.
- 3) Steel: All steel parts made of carbon steel.
- 4) Resist NR size 15 - 35: Ball runner block body made of corrosion-resistant steel as per DIN EN 10088.
- 5) Resist NR II: All steel components are made from corrosion-resistant steel in accordance with DIN EN 10088.
- 6) Resist CR: Steel ball runner block body with corrosion-resistant coating, matte-silver finish, hard chrome plated.
- 7) Ball runner block BSHP
- 8) Ball runner block BSHP size 25 only

For short product names of the types, see the product description

Product overview Ball guide rails with rail lengths

Ball guide rails can be cut to length as desired by the customer. The maximum lengths for a one-piece rail section can be found in the following table and in the "Ball guide rails" chapter. If longer rails are required, Bosch Rexroth will supply them as multi-piece ball guide rails.

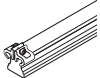
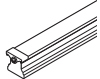
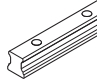
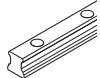
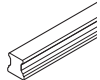
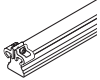
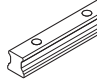
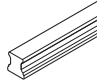
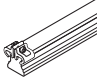
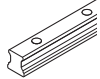
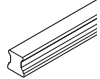
Ball guide rails		Page	Size							
			15	20	25	30	35	45	55	65
			Rail length (mm)							
Standard ball guide rails made of steel 	SNS / SNO R1605 .3. .. / R1605 .B. .. For bolting from above with cover strip and strip clamps	110	3836	5816	5816	5836	5836	5771	3836	3746
	 SNS / SNO R1605 .6. .. / R1605 .D. .. For bolting from above with cover strip and protective caps	112	3836	5816	5816	5836	5836	5771	3836	3746
	 SNS / SNO R1605 .0. .. / R1605 .C. .. For bolting from above with plastic caps	114	3836	5816	5816	5836	5836	5771	3836	3746
	 SNS R1606 .5. .. For bolting from above, for caps made of steel	116	-	-	5816	5836	5836	5771	3836	3746
	 SNS R1607 .0. .. For bolting from below	118	3836	5816	5816	5836	5836	5771	3836	3746
Standard ball guide rails Resist NR II¹⁾ 	SNS R2045 .3. .. For bolting from above with cover strip and strip clamps	120	1856	3836	3836	3836	3836	-	-	-
	 SNS R2045 .0. .. For bolting from above with plastic caps	121	1856	3836	3836	3836	3836	-	-	-
	 SNS R2047 .0. .. For bolting from below	121	1856	3836	3836	3836	3836	-	-	-
Standard ball guide rails Resist CR²⁾ 	SNS R1645 .3. .. For bolting from above with cover strip and strip clamps	122	3836	3836	3836	3836	3836	3776	3836	3746
	 SNS R1645 .0. .. For bolting from above with plastic caps	123	3836	3836	3836	3836	3836	3776	3836	3746
	 SNS R1647 .0. .. For bolting from below	123	3836	3836	3836	3836	3836	3776	3836	3746

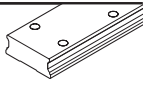
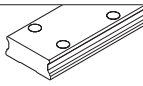
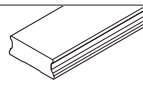
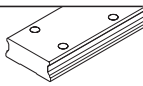
Ball guide rails		Page	Size		
			20/40	25/70	35/90
		Rail length (mm)			
Wide ball guide rails made of steel 	BNS R1675 .0. ... For bolting from above with plastic caps	134	3836	3836	3836
	 BNS R1676 .5. ... For bolting from above, for caps made of steel	136	-	3836	3836
	 BNS R1677 .0. ... For bolting from below	137	3836	3836	3836
Wide ball guide rails Resist CR²⁾ 	BNS R1673 .0. ... For bolting from above with plastic caps	134	3836	3836	3836

- 1) Resist NR II: Ball guide rail made of corrosion-resistant steel as per DIN EN 10088
- 2) Resist CR: Ball guide rail made of steel with corrosion-resistant coating, matte-silver finish, hard chrome plated

For short product names of the types, see the product description

General technical data and calculations

General notes

The general technical data and calculations apply to all ball rail systems i.e. to all ball runner blocks and ball guide rails.

Specific technical data relating to the individual ball runner blocks and ball guide rails is given separately.

Preload classes

To cover the widest possible range of applications, Rexroth ball runner blocks are available in different preload classes.

The following preload classes are available:

- ▶ Ball runner block without preload (preload class C0)
- ▶ Ball runner blocks with moderate preload (preload class C1)
- ▶ Ball runner blocks with average preload (preload class C2)
- ▶ Ball runner blocks with high preload (preload class C3)

To prevent reductions to the service life, the preload should not exceed 1/3 of the load on bearing F.

In general, the rigidity of the ball runner block rises with increasing preload. If vibrations occur, select a correspondingly high preload (\geq preload class C2).

Guide systems with parallel rails

When choosing the preload class, also pay attention to the permissible parallelism offset of the rails ("Accuracy class selection criterion").

When installing ball rail systems of accuracy class N, we recommend preload class C0 or C1 to avoid distortive stress due to the tolerances.

Speed

$$v_{\max} : 3-10 \text{ m/s}$$

For exact values, see the individual ball runner blocks.

Acceleration

$$a_{\max} : 250-500 \text{ m/s}^2$$

For exact values, see the individual ball runner blocks.

(If $F_{\text{comb}} > 2.8 \cdot F_{\text{pr}}$: $a_{\max} = 50 \text{ m/s}^2$)

If preload force F_{pr} is canceled, $a_{\max} = 50 \text{ m/s}^2$ applies

Operating temperature range

$$t : 0-80 \text{ }^{\circ}\text{C}$$

Up to 100°C is permissible for a short time.

For operation at negative temperatures, please consult us.

For ball runner blocks without ball chain:

Lower limit $-10 \text{ }^{\circ}\text{C}$.

Friction

The friction coefficient μ of Rexroth's ball rail system is approximately 0.002 to 0.003 (without the friction of the seal).

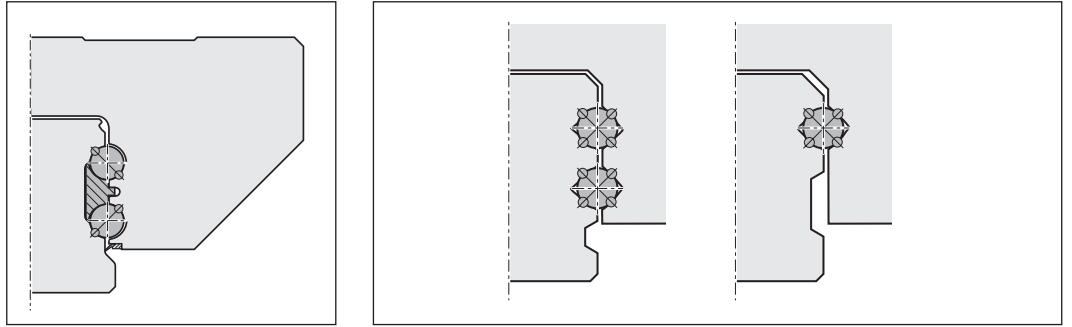

Due to the Rexroth design with four rows of balls, there are always **two points of contact** in all directions of loading. This reduces the friction to a minimum.

Other ball rails with two or four rows of balls with **four points of contact** have multiple friction: due to the differential slip with lateral loading and with a comparable preload without load, the gothic raceway profile causes higher friction (depending on the conformity and the load, up to five times the friction coefficient). This high friction leads correspondingly to greater heat.

Seals

Seals are used to prevent dirt, chips and coolants, etc. from working their way into the inside of the ball runner block, thereby preventing reductions to its service life. For more information, see "Selection criteria / Seals".

Standard seal (SS)

Universal seals are fitted as standard in Rexroth ball runner blocks. They have a uniform sealing effect for ball guide rails with and without cover strips. Low friction and a good sealing effect have both been taken into account in the design. For applications where effective sealing is required.

Low-friction (LS)

For special requirements with regard to ease of movement.

Double-lip seal (DS)

For increased exposure to media

Front seal

For applications in environments with fine dirt or metal particles, as well as coolants or cutting fluids.

Interchangeable during servicing.

Front seals are available as accessories for mounting by the customer.

FKM seal

For applications in extreme environments with fine dirt or metal particles, as well as heavy use of coolants or cutting fluids.

Interchangeable during servicing.

FKM front seals are available as accessories for mounting by the customer.

Cover plate wiper

For use in environments with coarse dirt or chips.

Cover plate wipers are available as accessories for mounting by the customer.

General technical data and calculations

How to select a linear guide system according to DIN 637 is described on page 10. The necessary calculations are explained in the following chapter. They are integrated in the "Linear Motion Designer" calculation program. You will find the link to the download in the chapter "further information".

Forces and moments

In Rexroth ball rail systems the raceways are arranged at a pressure angle of 45°. This results in the same high load capacity of the entire system in all four main directions of loading.

The ball runner blocks may be subjected to both forces and load moments.

Forces in the four main directions of loading

- ▶ Tension F_z (positive z-direction)
- ▶ Pressure $-F_z$ (negative z-direction)
- ▶ Side load F_y (positive y-direction)
- ▶ Side load $-F_y$ (negative y-direction)

Moments

- ▶ Torsional moment M_x (around the x-axis)
- ▶ Longitudinal moment M_y (around the y-axis)
- ▶ Longitudinal moment M_z (around the z-axis)

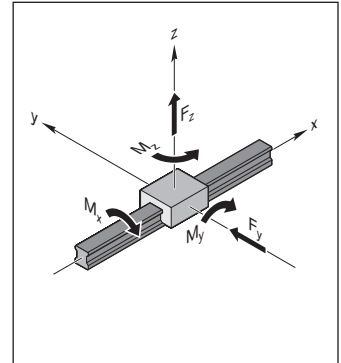

Definition of load capacities

Dynamic load capacity C

The radial load (whose extent and direction does not change) that a linear anti-friction bearing can theoretically absorb for a nominal life covering 10^5 m (according to DIN ISO 14728-1).

Note: The dynamic load capacities in the tables are above the DIN or ISO values.

These values have been confirmed in tests.

Static load capacity C_0

Static load in the direction of loading that corresponds to a calculated load in the center of the contact point with the greatest load between the ball and raceway of 4200 MPa.

Note: With this stress at the contact point, permanent overall deformation of the ball and the track zone occurs that corresponds to about 0.0001 times the ball diameter (according to DIN ISO 14 728-1).

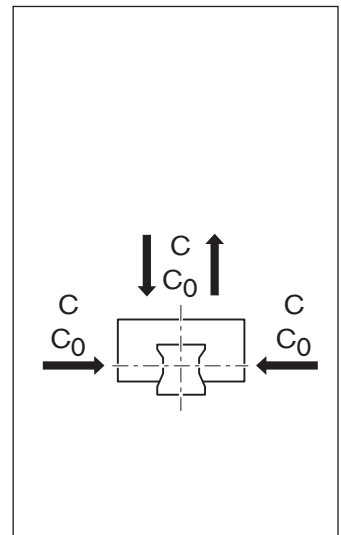

Definition of load moment capacities

Dynamic torsional moment load capacity M_t

Comparative dynamic moment around the X-axis, which causes a load equivalent to the dynamic load capacity C.

Static torsional moment load capacity M_{t0}

The comparable static moment around the x-axis that induces a load corresponding to the static load capacity C_0 .

Dynamic longitudinal moment load capacity M_L

The dynamic comparable moment around the transverse axis y or the vertical axis z that induces a load corresponding to the dynamic load capacity C.

Static longitudinal moment load capacity M_{L0}

The static comparable moment around the transverse axis y or the vertical axis z that induces a load corresponding to the static load capacity C_0 .

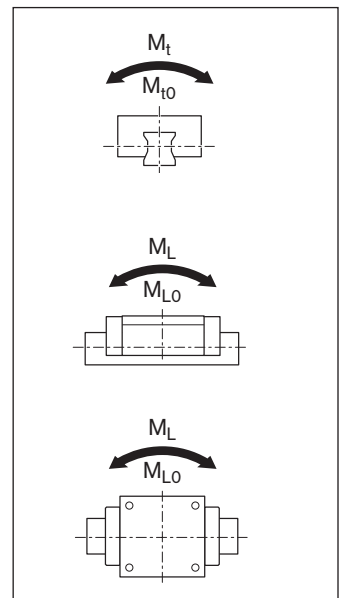

Definition and calculation of the nominal service life

The calculated service life which an individual linear rolling bearing, or a group of apparently identical rolling bearings operating under the same conditions, can attain with a 90% probability, with contemporary, commonly used materials and manufacturing quality under conventional operating conditions (as per DIN ISO 14728-1).

Nominal service life in meters

$$(1) L_{10} = \left(\frac{C}{F_m} \right)^3 \cdot 10^5 \text{ m}$$

Service life in operating hours with constant stroke and constant stroke repetition rate

$$(2) L_{h10} = \frac{L_{10}}{2 \cdot s \cdot n \cdot 60}$$

If the stroke length s and the stroke repetition rate n are constant over the total service life, you can use formula (2) to determine the service life in operating hours.

Nominal service life at variable travel speed

$$(3) L_{h10} = \frac{L_{10}}{60 \cdot v_m}$$

As an alternative, it is possible to use formula (3) to calculate the service life in operating hours using the average speed v_m .

This average speed v_m is calculated with speeds that can be changed on a stepwise basis using the time steps q_{tn} of the individual load stages (4).

$$(4) v_m = \frac{|v_1| \cdot q_{t1} + |v_2| \cdot q_{t2} + \dots + |v_n| \cdot q_{tn}}{100\%}$$

Modified life expectancy

$$L_{na} = a_1 \cdot \left(\frac{C}{F_m} \right)^3 \cdot 10^5 \text{ m}$$

If a 90 percent requisite reliability is not enough, you must reduce the service life values by a factor of a_1 in accordance with the table below.

$$L_{ha} = \frac{L_{na}}{2 \cdot s \cdot n \cdot 60}$$

Requisite reliability (%)	L_{na}	Factor a_1
90	L_{10a}	1.00
95	L_{5a}	0.64
96	L_{4a}	0.55
97	L_{3a}	0.47
98	L_{2a}	0.37
99	L_{1a}	0.25

Notes

DIN ISO 14728-1 limits the validity of the formula (1) to dynamically equivalent loads $F_m < 0.5$. However, in our tests we verified that under ideal operating conditions this service life formula can be applied up to loads of $F_m = C$. Under some circumstances, with stroke lengths below $2 \cdot$ ball runner block length B_1 (see the dimension tables) a load capacity reduction may be required. Please consult us.

General technical data and calculations

Load on bearing for calculating the service life

Note

In general, both the static and dynamic load ratios should not be below the minimum value of 4.0. In the case of applications that place high demands on rigidity and/or the service life, a higher load ratio is required. With tensile loads, check the screw stability. See the chapter "Instruction for mounting".

Dynamic load ratio

$$\frac{C}{F_{m, \max}}$$

Static load ratio

$$\frac{C_0}{F_{\text{eff}, \max}}$$

Combined equivalent bearing load

In the case of a combined vertical and horizontal external load, calculate the dynamically equivalent load F_{comb} according to formula (5).

Note

The structure of the ball rail system permits this simplified calculation.

$$(5) \quad F_{\text{comb}} = |F_y| + |F_z|$$

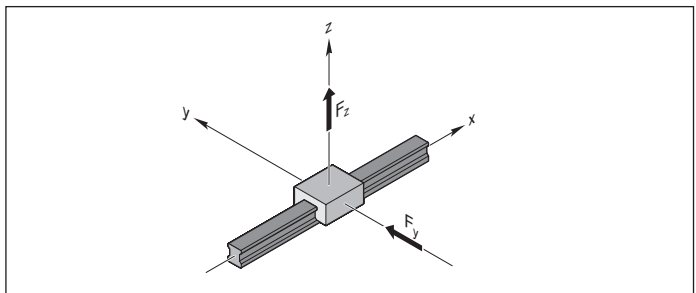

Note

Reduce an external load that affects the ball runner block at any angle with the correct sign to F_y and F_z and insert the amounts into formula (5) or (6).

Combined equivalent load on bearing in conjunction with moments

Using formula (6), you can combine all the partial loads that occur in a load case into one single comparison load, i.e. the combined equivalent load on bearing.

$$(6) \quad F_{\text{comb}} = |F_y| + |F_z| + C \cdot \frac{|M_x|}{M_t} + C \cdot \frac{|M_y|}{M_L} + C \cdot \frac{|M_z|}{M_L}$$

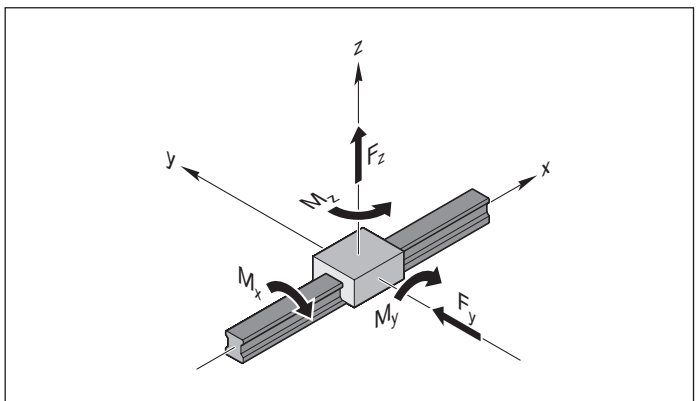

Notes

Including moments as stated in formula (6) only applies to an individual ball guide rail with just one ball runner block. The formula is simpler for other combinations.

The forces and moments plotted in the coordinate system can also have an effect in the opposite direction. Reduce an external load that affects the ball runner block at any angle to F_y and F_z and insert the amounts into formula (6). The structural design of the ball runner blocks allows this simplified calculation.

Considering the internal preload force F_{pr}

To increase the rigidity and precision of the guide system, it is advisable to use preloaded ball runner blocks (cf. "System preload selection criterion").

When using ball runner blocks of preload classes C2 and C3, it may be necessary to consider the internal preload force; this is because both rows of balls a and b are preloaded against one another by a specific oversize at an internal preload force F_{pr} and deform by the amount δ_{pr} (see the diagram).

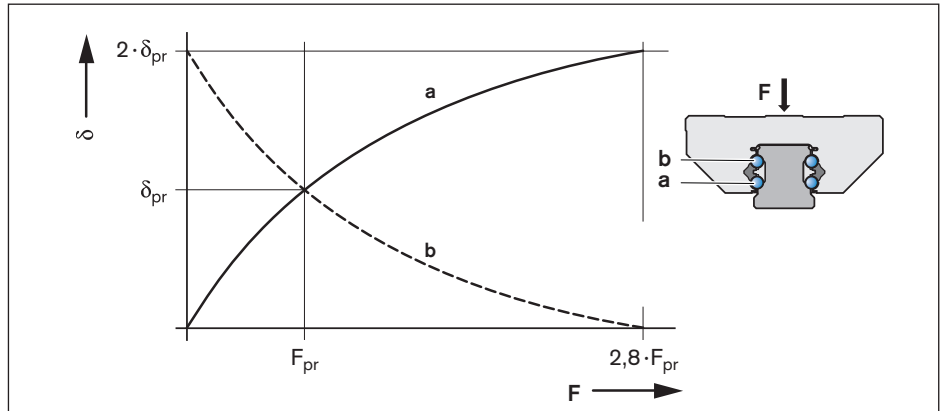

- a = Loaded (lower) row of balls (N)
- b = Non-loaded (upper) row of balls (N)
- δ = Deformation of rolling contact at F (-)
- δ_{pr} = Deformation of rolling contact at F_{pr} (-)
- F = Load on the ball runner block (N)
- F_{pr} = Internal preload force (N)

Effective equivalent load on bearing

From an external load amounting to 2.8 times the internal preload force F_{pr} onward, a row of balls becomes preload-free.

Note

Under highly dynamic load conditions, the combined equivalent bearing load should be $F_{comb} < 2.8 \cdot F_{pr}$ to prevent damage to anti-friction bearings due to slippage.

$$(7) \quad F_{eff} = F_{comb}$$

Case 1

$F_{comb} > 2.8 \cdot F_{pr}$
In this case, the internal preload force F_{pr} does not affect the service life.

$$(8) \quad F_{eff} = \left(\frac{F_{comb}}{2.8 \cdot F_{pr}} + 1 \right)^{3/2} \cdot F_{pr}$$

Case 2

$F_{comb} \leq 2.8 \cdot F_{pr}$
The preload force F_{pr} is included in the calculation of the effective equivalent load on bearing.

General technical data and calculations

Dynamically equivalent load on bearing

The determination of the dynamic equivalent load on bearing F_m for the calculation of the service life is implemented according to portions of distance q_m according to formula (9).

$$(9) F_m = \sqrt[3]{(F_{eff\ 1})^3 \cdot \frac{q_{s1}}{100\ \%} + (F_{eff\ 2})^3 \cdot \frac{q_{s2}}{100\ \%} + \dots + (F_{eff\ n})^3 \cdot \frac{q_{sn}}{100\ \%}}$$

Equivalent static load on bearing

With a combined vertical and horizontal external static load in conjunction with a static torsional or longitudinal moment, calculate the static equivalent load on bearing $F_{0\ comb}$ according to formula (10).

$$(10) F_{0\ comb} = |F_{0y}| + |F_{0z}| + C_0 \cdot \frac{|M_{0x}|}{M_{t0}} + C_0 \cdot \frac{|M_{0y}|}{M_{L0}} + C_0 \cdot \frac{|M_{0z}|}{M_{L0}}$$

Notes

The static equivalent load on bearing $F_{0\ comb}$ must not exceed the static load capacity C_0 . Formula (10) only applies when using a single ball guide rail.

Reduce an external load that affects the ball runner block at any angle to F_{0y} and F_{0z} and insert the amounts into formula (10).

Definitions and calculation for dynamic and static load ratios

Using the ratio of load capacity to load of the ball runner blocks, you can make a preselection of the guideway. The dynamic loading ratio C/F_{max} and the static loading ratio C_0/F_{0max} should be selected according to the application. The necessary load capacities are calculated from this. The load capacity overview yields the corresponding dimensions and format.

Guideline values for load ratios

The table below contains guideline values for the load ratios. The table values are offered merely as a rough guide reflecting typical customer requirements (e.g. service life, accuracy, rigidity) by sector and application.

Case 1: Static load $F_{0max} > F_{max}$:

Case 2: Static load $F_{0max} < F_{max}$:

$$\text{Dynamic ratio} = \frac{C}{F_{max}}$$

$$\text{Static ratio} = \frac{C_0}{F_{0max}}$$

$$\text{Static ratio} = \frac{C_0}{F_{max}}$$

Machine type/sector	Application example	C/Fmax	C ₀ /F _{0max}
Machine tools	General	6 ... 9	> 4
	Turning	6 ... 7	> 4
	Milling	6 ... 7	> 4
	Grinding	9 ... 10	> 4
	Engraving	5	> 3
Rubber and plastics processing machinery	Injection molding	8	> 2
Woodworking and wood processing machines	Sawing, milling	5	> 3
Area of mounting/handling technology and industrial robots	Handling	5	> 3
Oil hydraulics and pneumatics	Lifting/lowering	6	> 4

Static load safety factor S_0

You must verify mathematically any structural design involving rolling contact with regard to the static load safety factor. The static load safety factor for a linear guide results from the following equation:

$$S_0 = \frac{C_0}{F_{0\max}}$$

In this connection, $F_{0\max}$ represents the maximum load amplitude that can occur, which can affect the linear guide. It does not matter whether this load is exerted only for a short period. It may represent the peak amplitude of an overall dynamic loading. For sizing, the data shown in the table applies.

Static load safety factor S_0	Conditions of use
Overhead hanging arrangements or applications with serious potential risks	≥ 12
High dynamic load when at standstill, contamination.	8 - 12
Normal sizing of machinery and plants without full knowledge of the load parameters or connection details.	5 - 8
Full knowledge of all the load data. Vibration-free operation is ensured.	3 - 5







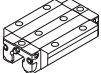

Key to formulas

Formula	Unit	Designation
a_1	–	Life expectancy factor
C	N	Dynamic load capacity
C_0	N	Static load capacity
F_{\max}	N	Maximum dynamic load
$F_{0\max}$	N	Maximum static load
F_{comb}	N	Combined equivalent bearing load
$F_{0\text{comb}}$	N	Equivalent static load on bearing
F_{eff}	N	Effective equivalent load on bearing
$F_{\text{eff } 1-n}$	N	Uniform effective individual loads
F_m	N	Dynamically equivalent load on bearing
F_{pr}	N	Preload force
F_y	N	External load due to a resulting force in the y-direction
F_{0y}	N	External load due to a static force in the y-direction
F_z	N	External load due to a resulting force in the z-direction
F_{0z}	N	External load due to a static force in the z-direction
M_t	Nm	Dynamic torsional moment load capacity ¹⁾
M_{t0}	Nm	Static torsional moment load capacity ¹⁾
M_L	Nm	Dynamic longitudinal moment load capacity ¹⁾
M_{L0}	Nm	Static longitudinal moment load capacity ¹⁾
M_x	Nm	Load due to the resultant moment around the x-axis
M_{0x}	Nm	Load due to the static moment around the x-axis

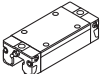
Formula	Unit	Designation
M_y	Nm	Load due to the resultant moment around the y-axis
M_{0y}	Nm	Load due to the static moment around the y-axis
M_z	Nm	Load due to the resultant moment around the z-axis
M_{0z}	Nm	Load due to the static moment around the z-axis
L_{10}	m	Nominal life (travel range)
$L_{h 10}$	h	Nominal life (time)
L_{na}	m	Modified life expectancy (travel range)
L_{ha}	h	Modified life expectancy (time)
n	min ⁻¹	Stroke repetition rate (full cycles)
s	m	Stroke length
S_0	–	Static load safety factor
v_m	m/min	Average linear speed
$v_1 \dots v_n$	m/min	Travel speeds of phases 1 ... n
$q_{t1} \dots q_{tn}$	%	Discrete time steps for $v_1 \dots v_n$ of phases 1 ... n

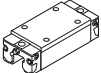





Refer to the table for the values

Format and version



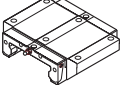
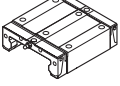

Ball runner blocks		Application area	Load-bearing capacity	Special feature	
Standard ball runner blocks made of steel		FNS R1651 ¹⁾²⁾⁵⁾ R2001 ³⁾⁴⁾	For high rigidity requirements	High	For bolting from above and below
		FLS R1653 ¹⁾²⁾⁵⁾ R2002 ³⁾	For the most demanding rigidity requirements	Very high	For bolting from above and below
		FKS R1665 R2000 ³⁾	For restricted space in the longitudinal direction	Middle	For bolting from above and below Supplementary to DIN 645-1
		SNS R1622 ¹⁾²⁾⁵⁾ R2011 ³⁾⁴⁾	For restricted space in the transverse direction	High	For mounting from above
		SLS R1623 ¹⁾²⁾⁵⁾ R2012 ³⁾	For restricted space in the transverse direction	Very high	For mounting from above
		SKS R1666 R2010 ³⁾	For restricted space in longitudinal and transverse direction	Middle	For mounting from above
		SNH R1621 ¹⁾²⁾⁵⁾	For restricted space in the transverse direction and high rigidity requirements	High	Higher rigidity than SNS
		SLH R1624 ¹⁾²⁾⁵⁾	For restricted space in the transverse direction and high rigidity requirements	Very high	Higher rigidity than SLS
	Standard ball runner blocks made of steel and Resist CR		FNN R1693 ²⁾	For restricted upward space	High
		FKN R1663 ²⁾	For restricted upward and longitudinal space	Middle	Lower rigidity than FKS Not defined in DIN 645-1
		SNN R1694 ²⁾	For restricted upward and longitudinal space	High	Lower rigidity than SNS Not defined in DIN 645-1
		SKN R1664 ²⁾	For restricted space in the upward, longitudinal and transverse direction	Middle	Lower rigidity than SKS Not defined in DIN 645-1

- 1) Heavy-duty ball runner block
- 2) Ball runner block BSHP
- 3) Resist NR
- 4) Resist NR II
- 5) Resist CR

For short product names of the types, see the product description

Ball runner blocks	Application area	Load-bearing capacity	Special feature
Super ball runner blocks made of steel and Resist CR 	FKS R1661 For compensating large tolerances in the adjoining structure	Middle	At least 2 ball runner blocks required per rail
	SKS R1662 For compensating large tolerances in the adjoining structure	Middle	At least 2 ball runner blocks required per rail
Aluminum ball runner blocks 	FNS R1631²⁾ For light-weight construction type for compensating low tolerances with connected structures	High	For bolting from above and below
	SNS R1632²⁾ For light-weight construction type for compensating low tolerances with connected structures	High	For bolting from above
High-speed ball runner blocks made of steel 	FNS R2001 ... 9.²⁾ For maximum travel speeds (up to 10 m/s)	High	For bolting from above and below
	SNS R2011 ... 9.²⁾ For maximum travel speeds (up to 10 m/s)	High	For bolting from above
Wide ball runner blocks made of steel and Resist CR 	BNS R1671²⁾ For high torsional moments on rails	Very high	For bolting from above and below
	CNS R1672²⁾ For high torsional moments on rails with restricted lateral space	Very high	For bolting from above

Format and version

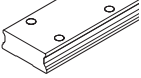
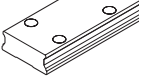
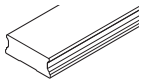





Ball guide rails	Application area	Fastening type	Special feature
Standard ball guide rails made of steel 	SNS / SNO R1605 .3. .. R1605 .B. .. R1645 .3. ..²⁾ R2045 .3. ..¹⁾	Standard version, very harsh environments, robust strip clamp	For bolting from above With cover strip and strip clamp. A single cover for all bores. No end-face bore required for strip clamp.
	SNS / SNO R1605 .6. .. R1605 .D. ..	Harsh environments compact strip clamp	For bolting from above With cover strip and protective cap. A single cover for all bores.
	SNS / SNO R1605 .0. .. R1605 .C. .. R1645 .0. ..²⁾ R2045 .0. ..¹⁾	Inexpensive	For bolting from above With plastic caps. No extra space required at the end face.
	SNS R1606 .5. ..	More resistant to mechanical influences (e.g. shocks) Very harsh environments	For bolting from above With steel caps. No extra space required at the end face.
	SNS R1607 .0. .. R1647 .0. ..²⁾ R2047 .0. ..¹⁾	Easy access to the mounting base underside, best sealing action of end seals	For bolting from below Use of larger screws than for bolting from above. Greater side loads permitted. No extra space required at the end face.
Wide ball guide rails made of steel 	BNS R1675 .0. .. R1673 .0. ..²⁾	High moment rigidity	For bolting from above With plastic caps. No extra space required at the end face.
	BNS R1676 .5. ..	High moment rigidity, more resistant to mechanical influences (e.g. shocks) Very harsh environments	For bolting from above With steel caps. No extra space required at the end face.
	BNS R1677 .0. ..	High moment rigidity, best sealing action of end seals	For bolting from below Use of larger screws than for bolting from above. Larger side loads are permitted than for the single-row series. No extra space required at the end face.

1) Resist NR II

2) Resist CR

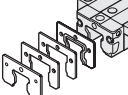
For short product names of the types, see the product description

Accessories

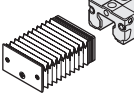
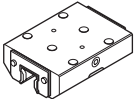
Accessories Connection elements are available as options for the ball runner blocks	Application area
Cover plate wiper 	The cover plate wiper is an additional element for wiping off coarse particles or dealing with contamination that has been deposited on the ball guide rail. When making your selection, please note whether the ball guide rail is used with or without cover strips.
Front seal Two-piece 	The front seal effectively prevents dirt, liquid or small particles from entering the ball runner block. This means that the sealing effect is improved even more. The two-part front seal can also be retrofitted via the ball guide rail.
FKM seal One and two-piece 	Better sealing effect than front seal but higher friction. Used for very heavy contamination, cooling lubricants or aggressive media. Chemical and temperature resistant.
Seal kit 	When using cover plate wiper and front seal simultaneously, the seal kit is recommended.
Lubrication adapter 	For oil and grease lubrication from above for ball runner blocks SNH and SLH (high versions).
Lubrication plate 	Enables further variations for lubrication of ball runner blocks; Available for lube connection with metric thread or pipe thread.
Front lube unit 	For applications requiring very long relubrication intervals. They allow travel distances of up to 25,000 km without relubrication under normal loads. The function is only assured where there is no exposure to liquids and little contamination. The maximum operating temperature is 60 °C.
Bellows 	Bellows are available in various versions, with or without lubrication plate. Bellows in heat-resistant design are metalized on one side and are therefore not flammable, resistant to sparks, welding spatter or hot chips. Temperature stability briefly up to 200 °C and operating temperature of 80 °C possible.
Clamping and braking units 	Clamping units can be used to secure the ball rail system against displacement in the static state. With braking units, the ball rail system can be braked in the dynamic state and secured against displacement in the resting state. The following versions are available: Hydraulic, pneumatic and manual clamping units.

System preload

Definition of preload

Ball runner blocks can be preloaded to increase rigidity. The internal preload forces that occur in this connection must be considered in the life expectancy calculation. You can choose the preload class to match the area of application. Refer to the table for preload force F_{pr} .

Example

- ▶ Area of application: Precise guide systems with low external load and high overall rigidity requirements. This results in preload class C1.
- ▶ Selected ball runner block FNS R1651 314 20
- ▶ The selected ball runner block yields a preload force F_{pr} according to the table.
- ▶ It is installed at 840 N internal preload force F_{pr} .

Code	Preload	Application area
C0 ¹⁾	Without preload (clearance)	For particularly smooth-running guide systems with the lowest possible friction for applications with large installation tolerances. Clearance versions are available only in accuracy classes N and H.
C1	Moderate preload	For precise guide systems with low external loads and high demands on overall rigidity.
C2	Medium preload	For precise guide systems with both high external loading and high demands on overall rigidity; also recommended for single-rail systems. Above average moment loads can be absorbed without significant elastic deformation. Further improved overall rigidity with only medium moment loads.
C3	High preload	For highly rigid guide systems, e.g. precision tooling machines etc. Above-average loads and moments are caught with the lowest possible elastic deformation. Ball runner blocks with preload C3 only available in accuracy classes UP, SP and XP, heavy duty ball runner blocks only available in UP, SP and P.

1) In the case of ball runner blocks without preload (preload class C0), there is a clearance between the ball runner block and the rail of 1 to 10 µm. When using two rails and more than one ball runner block per rail, this clearance is usually equalized by parallelism tolerances.

Preload force F_{pr}

Ball runner blocks	Material numbers	Format	Preload class	Size								
				15	20	25	30	35	45	55	65	
				Preload force F_{pr} (N)								
Standard ball runner blocks, heavy-duty ball runner blocks - Steel ³⁾ - Resist NR ⁴⁾ - Resist CR ⁶⁾	R1651 ³⁾⁶⁾ R2001 ⁴⁾	FNS	C1 ¹⁾	160	380	460	630	840	1360	1960	2460	
	R1622 ³⁾⁶⁾ R2011 ⁴⁾	SNS	C1 ²⁾	150	350	430	590	840	1270			
	R1621 ³⁾⁶⁾	SNH	C2 ¹⁾	620	1500	1820	2540	3350	5450	7860	9840	
			C2 ²⁾	580	1390	1700	2340	3350	5060			
			C3 ¹⁾	1010	2440	2960	4120	5450	8850	12800	16000	
			C3 ²⁾	950	2260	2770	3810	5450	8230			
	R1653 ³⁾⁶⁾ R2002 ⁴⁾	FLS	C1 ¹⁾	200	490	610	800	1110	1810	2480	3260	
	R1623 ³⁾⁶⁾ R2012 ⁴⁾	SLS	C1 ²⁾	180	460	550	760	1060	1640			
	R1624 ³⁾⁶⁾	SLH	C2 ¹⁾	800	1950	2430	3200	4450	7230	9940	13000	
			C2 ²⁾	720	1850	2200	3040	4240	6550			
			C3 ¹⁾	1300	3170	3950	5200	7230	11800	16100	21200	
			C3 ²⁾	1170	3000	3580	4940	6890	10600			
Standard ball runner blocks - Steel ³⁾ - Resist NR ⁴⁾ - Resist CR ⁶⁾	R1665 ³⁾⁶⁾ R2000 ⁴⁾	FKS	C1 ¹⁾	110	250	320	440	590				
	R1666 ³⁾⁶⁾ R2010 ⁴⁾	SKS	C1 ²⁾	90	250	280	440	590				
	R1693 ³⁾⁶⁾	FNN	C1 ¹⁾		290	460						
	R1694 ³⁾⁶⁾	SNN										
	R1663 ³⁾⁶⁾ R1664 ³⁾⁶⁾	FKN SKN	C1 ¹⁾		190	320						
Super ball runner blocks - Steel ³⁾ - Resist CR ⁶⁾	R1661 ³⁾⁶⁾	FKS	C1 ¹⁾	80	200	230	320	420				
	R1662 ³⁾⁶⁾	SKS										
Standard high speed ball runner blocks - Steel	R2001...9.	FNS	C2 ¹⁾	420	1020	1240	1720	2280	3710			
	R2011...9.	SNS										
	R2002...9. R2012...9.	FLS SLS	C2 ¹⁾	700	1330	1660	2180	3020	4930		13000	
Standard ball runner blocks - Aluminum	R1631	FNS	C1 ¹⁾	160	380	460	630	840				
	R1632	SNS	C1 ²⁾	150	350	430	590	840				
Standard ball runner blocks - Resist NR II ⁵⁾	R2001...0.	FNS	C1 ¹⁾	100	250	300	420	550				
	R2011...0.	SNS	C1 ²⁾	90	230	280	390	550				
			C2 ¹⁾	410	980	1200	1660	2210				
			C2 ²⁾	380	910	1120	1540	2210				
	R2002...0. R2012...0.	FLS SLS	C1 ¹⁾	170	320	400	530	730				
			C1 ²⁾	150	300	360	500	700				
			C2 ¹⁾	680	1280	1600	2100	2920				
			C2 ²⁾	610	1220	1450	2000	2780				
	R2000...0. R2010...0.	FKS SKS	C1 ¹⁾	90	160	210	290	390				
			C1 ²⁾	80	160	180	290	390				
	Wide ball runner blocks - Steel ³⁾ - Resist CR ⁶⁾	R1671 ³⁾⁶⁾	CNS	C1 ¹⁾		270	580		1160			
C1 ²⁾					260	550						
R1672 ³⁾⁶⁾		BNS	C1 ¹⁾		270	580						
			C1 ²⁾		260	550						

- 1) Ball runner block **without** ball chain.
- 2) Ball runner block **with** ball chain.
- 3) Steel: All steel parts made of carbon steel.
- 4) Resist NR size 15 - 35: Ball runner block body made of corrosion-resistant steel as per DIN EN 10088.
- 5) Resist NR II: All steel components are made from corrosion-resistant steel in accordance with DIN EN 10088.
- 6) Resist CR: Steel ball runner block body with corrosion-resistant coating, matte-silver finish, hard chrome plated.

Rigidity ball runner blocks

Due to the large number of variants only one type is listed. Further rigidity diagrams are available on request.

Rigidity of the ball rail system with preload

Example

Ball runner blocks FNS

Flange, normal, standard height

Size 35:

- a) Ball runner block R1651 31. 20 for preload C1
- b) Ball runner block R1651 32. 20 for preload C2
- c) Ball runner block R1651 33. 20 for preload C3

Example

Ball runner blocks FLS

Flange, long, standard height

Size 35:

- a) Ball runner block R1653 31. 20 for preload C1
- b) Ball runner block R1653 32. 20 for preload C2
- c) Ball runner block R1653 33. 20 for preload C3

Example

Ball runner blocks SNS

Slimline, normal, standard height

Size 35:

- a) Ball runner block R1622 31. 20 for preload C1
- b) Ball runner block R1622 32. 20 for preload C2
- c) Ball runner block R1622 33. 20 for preload C3

Example

Ball runner blocks SLS

Slimline, long, standard height

Size 35:

- a) Ball runner block R1623 31. 20 for preload C1
- b) Ball runner block R1623 32. 20 for preload C2
- c) Ball runner block R1623 33. 20 for preload C3

Preload

C1/C2/C3 = In accordance with table for preload force F_{pr}

Key

δ_{el} = Elastic deformation (μm)
 F = Load (N)

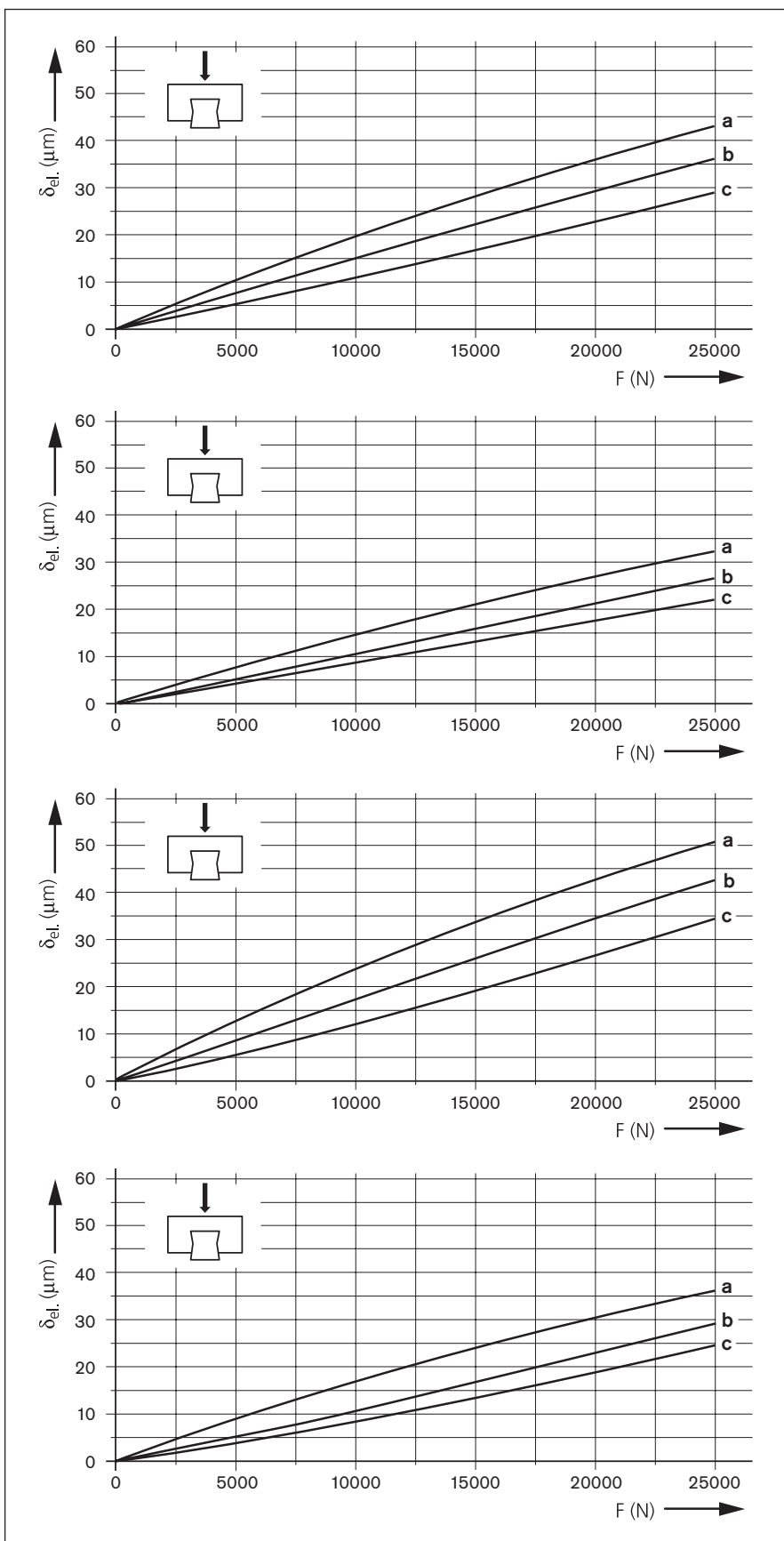

Accuracy classes

Accuracy classes and their tolerances

Ball rail systems are available in six accuracy classes for ball runner blocks and five for ball guide rails. For details of the available ball runner blocks and ball guide rails, see the "Material numbers" tables.

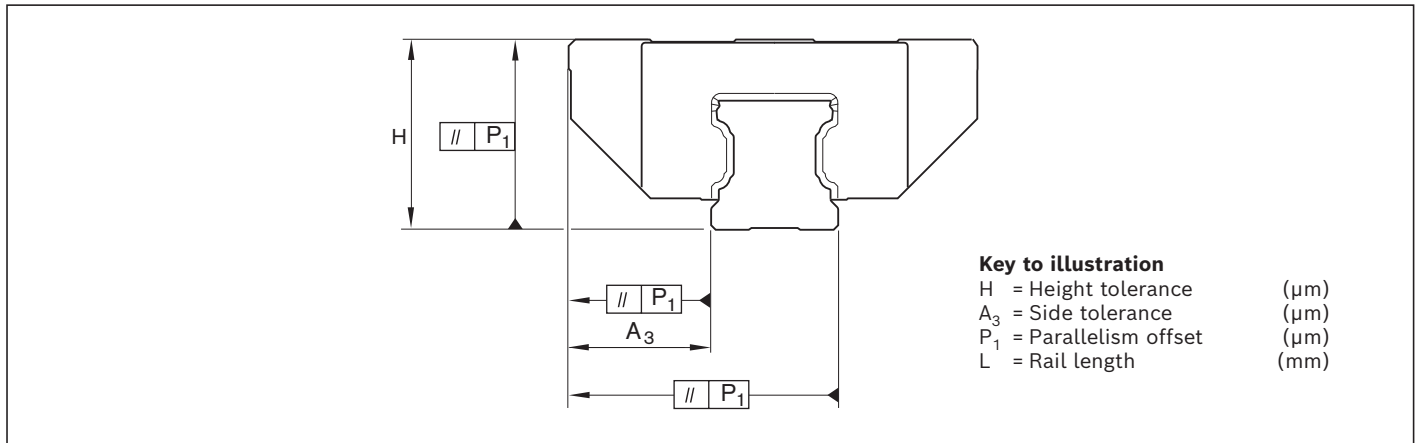

Precision manufacturing process makes interchangeability easy

Rexroth manufactures its ball guide rails and ball runner blocks with such high precision, especially in the ball raceway zone, that each individual component element is fully interchangeable. For example, a ball runner block can be used without problems on various ball guide rails of the same size. Similarly, different ball runner blocks can also be used on one and the same ball guide rail.

	H	A ₃	ΔH, ΔA ₃
Measured in middle of runner block		For any ball runner block/rail combination at any position along the entire rail length	

Ball rail system made of steel, aluminum, Resist NR and Resist NR II

Accuracy classes	Tolerances of the dimensions (µm)		Max. differences of dimensions H and A ₃ on one rail (µm)
	H	A ₃	
N	±100	±40	30
H	±40	±20	15
P	±20	±10	7
XP ¹⁾	±11	±8	7
SP	±10	±7	5
UP	±5	±5	3

1) Ball runner block with accuracy class XP, ball guide rail with accuracy class SP

Ball rail system, Resist CR, matte-silver, hard chrome plated

Accuracy classes	Tolerances of the dimensions (µm)				Max. differences of dimensions H and A ₃ on one rail (µm)	
	H		A ₃		Ball runner block/ball guide rail	Ball guide rail
	Ball runner block/ball guide rail	Ball guide rail	Ball runner block/ball guide rail	Ball guide rail		
H	+47 -38	+44 -39	±23	+19 -24	18	15

Accuracy classes

Parallelism offset P_1 of the ball rail system in operation

Values measured at middle of runner block with ball rail systems without surface coating.

For hard chrome plated ball guide rails Resist CR, the values can increase up to 2 μm .

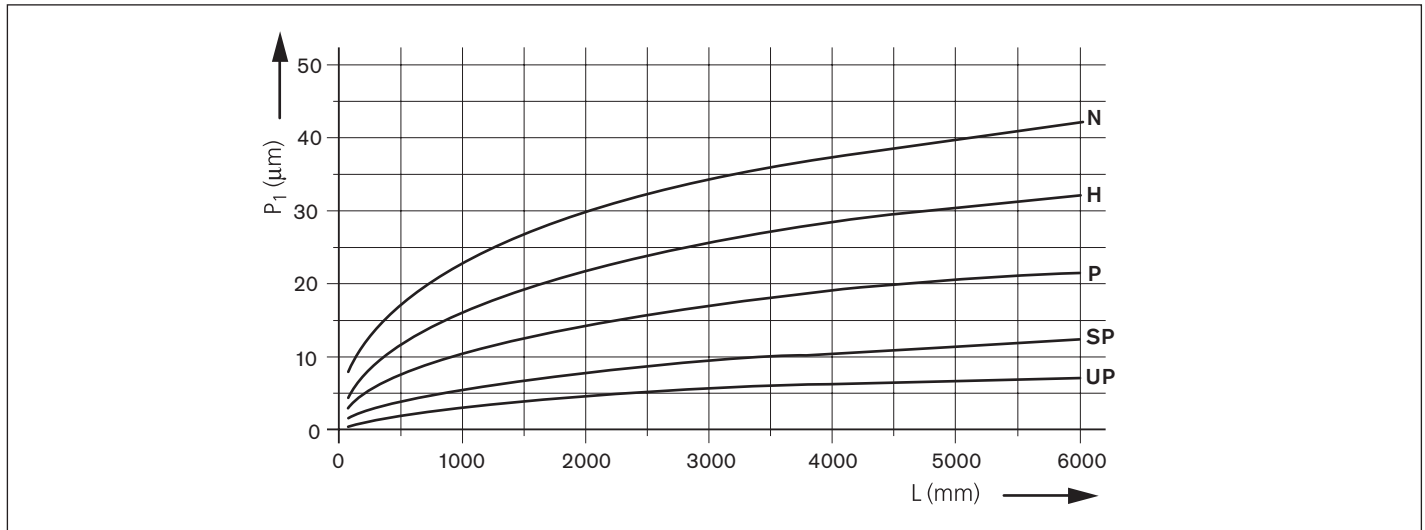

Tolerances for combination of accuracy classes

Ball runner blocks		Ball guide rails				
		N (μm)	H (μm)	P (μm)	SP (μm)	UP (μm)
N	Tolerance of dimension H (μm)	± 100	± 48	± 32	± 23	± 19
	Tolerance of dimension A_3 (μm)	± 40	± 28	± 22	± 20	± 19
	Max. diff. dimensions H and A_3 on one rail (μm)	30	30	30	30	30
H	Tolerance of dimension H (μm)	± 92	± 40	± 24	± 15	± 11
	Tolerance of dimension A_3 (μm)	± 32	± 20	± 14	± 12	± 11
	Max. diff. dimensions H and A_3 on one rail (μm)	15	15	15	15	15
P	Tolerance of dimension H (μm)	± 88	± 36	± 20	± 11	± 7
	Tolerance of dimension A_3 (μm)	± 28	± 16	± 10	± 8	± 7
	Max. diff. dimensions H and A_3 on one rail (μm)	7	7	7	7	7
XP	Tolerance of dimension H (μm)	± 88	± 36	± 20	± 11	± 7
	Tolerance of dimension A_3 (μm)	± 28	± 16	± 10	± 8	± 7
	Max. diff. dimensions H and A_3 on one rail (μm)	7	7	7	7	7
SP	Tolerance of dimension H (μm)	± 87	± 35	± 19	± 10	± 6
	Tolerance of dimension A_3 (μm)	± 27	± 15	± 9	± 7	± 6
	Max. diff. dimensions H and A_3 on one rail (μm)	5	5	5	5	5
UP	Tolerance of dimension H (μm)	± 86	± 34	± 18	± 9	± 5
	Tolerance of dimension A_3 (μm)	± 26	± 14	± 8	± 6	± 5
	Max. diff. dimensions H and A_3 on one rail (μm)	3	3	3	3	3

Recommendations for combining accuracy classes

Recommended with **relatively large ball runner block distances** and long strokes:

Ball guide rail in higher accuracy class than ball runner blocks.

Recommended with **small ball runner block distances** and short strokes:

Ball runner blocks in higher accuracy class than ball guide rail.

Travel accuracy selection criterion

By means of perfected ball inlet and outlet zones in the ball runner blocks and the optimized pitch of the fastening bores in the ball guide rails, a very high travel accuracy with lowest pulsation is achieved. Particularly suitable for highly precise, chipping processing, measuring technique, high-precision scanners, eroding technology etc.

(See chapter Product Description High-precision ball runner block BSHP made of steel, Application examples)

Ball chain

Rexroth recommends the ball chain especially for applications where a low noise level is required.

Ball runner blocks including ball chain (1) are available as an option. The ball chain prevents the balls from colliding with each other and helps to achieve a calmer and smoother running. A lower noise level is achieved. Due to the smaller number of load-bearing balls in the ball runner block with ball chain, lower load capacities and load moments can result ("Product overview with load capacities and load moments").

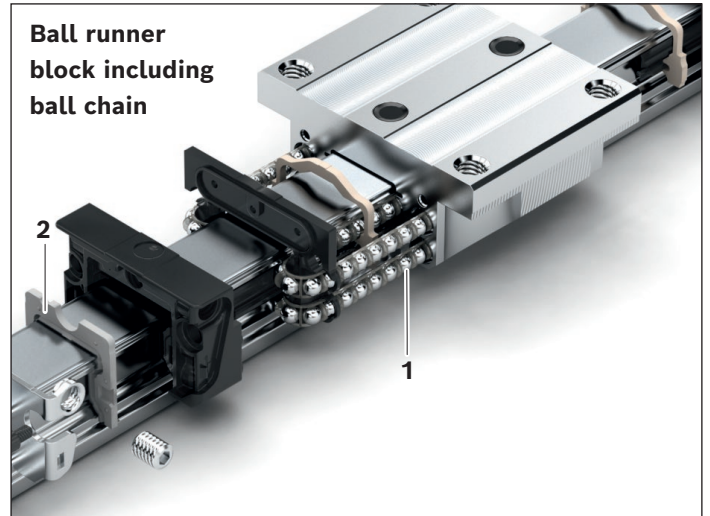

Seals

The sealing plate on the end face (2) protects the interior of the ball runner block against dirt, chips and fluids. Additionally, it prevents the discharge of lubricant. Due to the optimized form of the sealing lips, the occurring friction is reduced to a minimum. Sealing plates are optionally available with black standard seals (SS), beige low-friction seals (LS) or green double-lip seals (DS).

Low-friction seal (LS) (seal with very low friction)

For special requirements with regard to ease of movement and reduced lubricant application, the low-friction seal has been developed. It consists of an open-pored polyurethane foam and features only limited wiping action.

Standard seal (SS) (universal sealing with good sealing effect)

For most application cases, the standard seal is suitable. It comprises of a good wiping action but also enables long relubrication intervals.

Double-lip seal (DS) (sealing with very good sealing effect)

For applications in which the rail guide is heavily charged with chips, wood dust, cooling lubricants etc., Rexroth recommends the double-lip seal. It comprises an excellent wiping action but a greater friction force and lower relubrication interval.

Sealing effect and displacement resistance

The displacement resistance can be impacted by the geometry and the material. The diagram shows the effects of different sealing versions on the sealing effect and the displacement resistance.

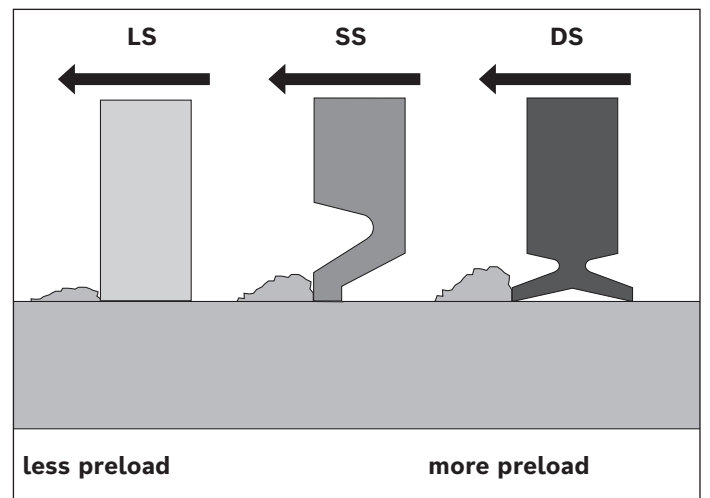
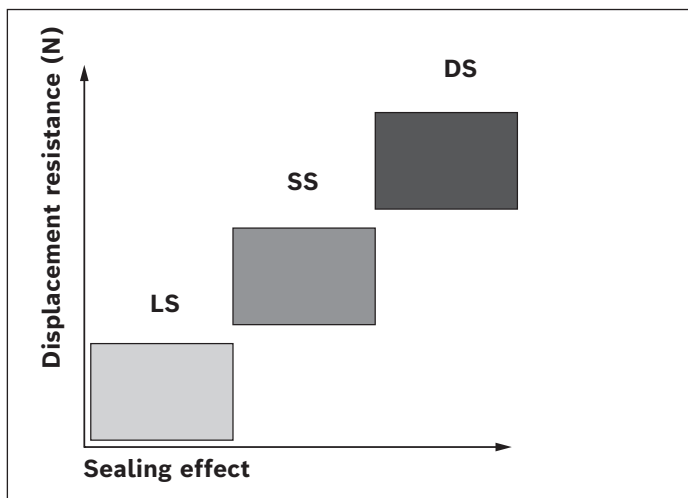

Materials

Rexroth offers ball runner blocks made of different materials for the different requirements in the various applications.

A Standard ball runner block made of steel

The most widely used carbon steel version.

Low-cost variant, but does not provide protection against corrosion.

Is usually sufficient for general mechanical engineering.

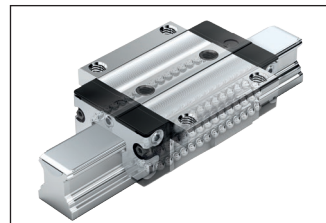

B High-speed ball runner block made of steel

In this variant, compared to the standard ball runner block made of steel, the steel balls are replaced by ceramic balls, or in case of size 65 by steel balls with pulse-reducing ball circulation. Due to the lower density of the ceramic balls or due to the pulse-reducing circulation of the steel ball, the same forces result in the deflections of the ball circulations at the increased permissible speed. As a result, even at speeds of up to 10 m/s (or 5 m/s at size 65 with steel ball), the expected service life is not reduced. In comparison with the standard version, the load capacities and load moments of the ball runner blocks with ceramic balls are slightly reduced.

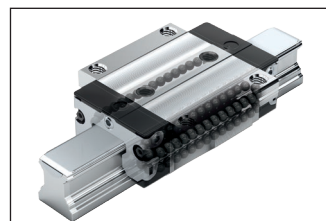

Limited corrosion-resistant ball runner blocks

C Aluminum ball runner block

The ball runner block body consists of a wrought aluminum alloy. Balls, steel bearing plate and end-face fastening screws are made of carbon steel. The ball runner blocks have the same load capacity as the standard version. As the yield point of aluminum is lower than that of steel, the maximum load capacity of the ball runner blocks is limited by F_{max} and M_{max} . Most cost-effective alternative with limited corrosion protection.

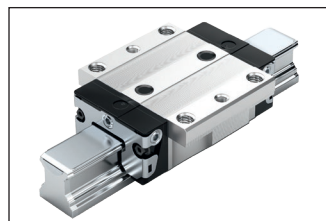

Corrosion-resistant ball runner blocks

D Resist NR

The ball runner block body is made of corrosion-resistant material. Offers limited corrosion protection.

Balls, steel bearing plate and end-face fastening screws are made of carbon steel. The ball runner blocks have the same basic load capacities and load moments as the standard version.

Rexroth recommends this version for applications requiring corrosion protection.

Fast delivery.

E Resist NR II

All parts of the ball runner block are made of corrosion-resistant material. These ball runner blocks offer the greatest possible protection against corrosion with only slightly reduced load capacities and load moments.

F Resist CR

The ball runner block body is coated with a corrosion-resistant coating, matte-silver, hard chrome plated. Balls, steel bearing plate and end-face fastening screws are made of carbon steel.

The ball runner blocks have the same basic load capacities and load moments as the standard version.

Alternative if the NR version is not available.

Material specifications

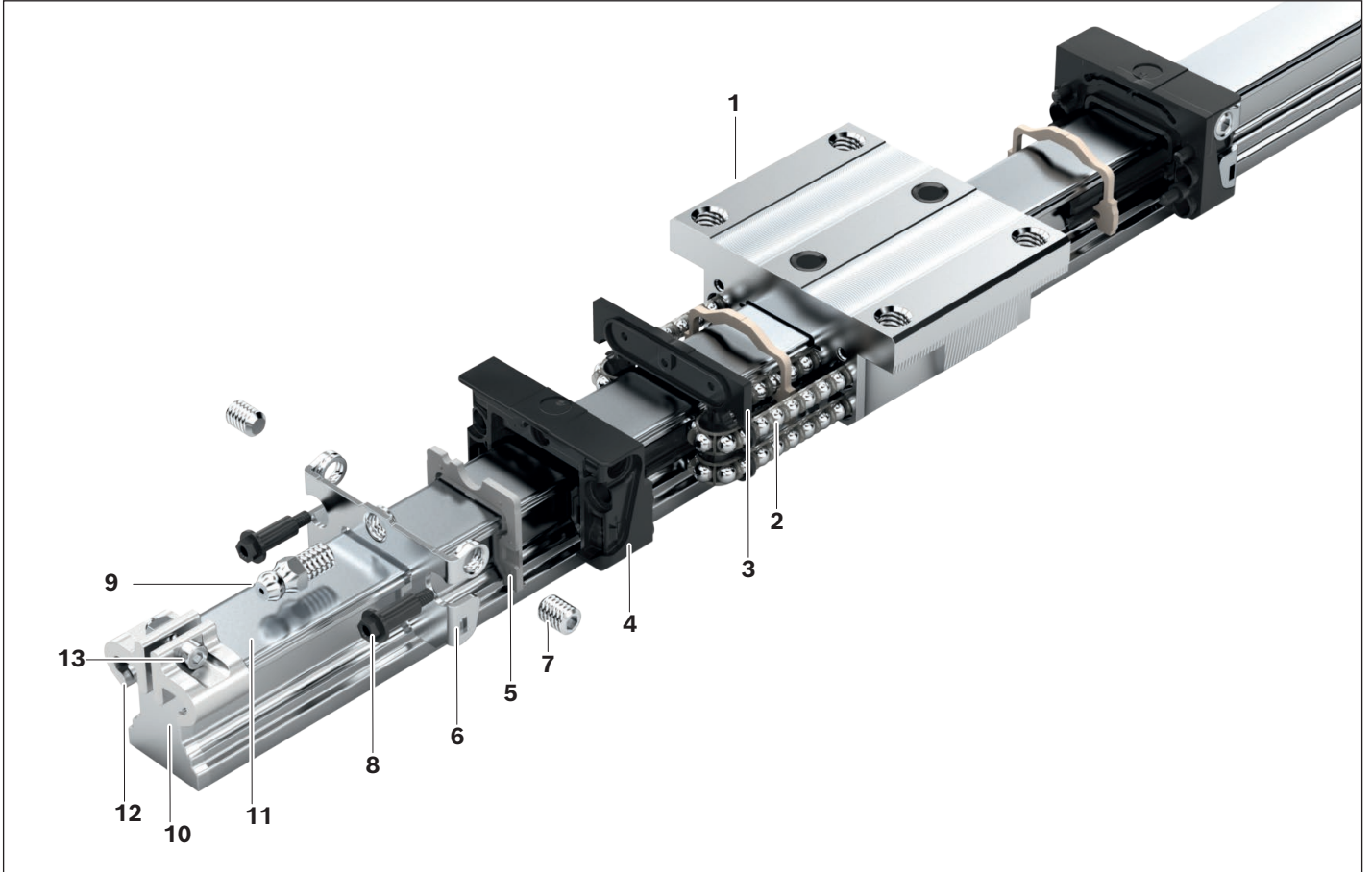

Item	Component	Ball runner blocks					
		A Steel	B Steel (high-speed)	C Aluminum	D Resist NR	E Resist NR II	F Resist CR
1	Ball runner block body	Heat-treated steel	Heat-treated steel	Wrought aluminum alloy	Corrosion-resistant steel 1.4122	Corrosion-resistant steel 1.4122	Hard chrome-plated heat-treated steel
2	Balls	Anti-friction bearing steel	Si ₃ N ₄ , anti-friction bearing steel (at size 65)	Anti-friction bearing steel	Anti-friction bearing steel	Corrosion-resistant steel 1.4112	Anti-friction bearing steel
3	Diversion plate	Plastic TEE-E					
4	Ball guide	Plastic strip POM (PA6.6)					
5	Sealing plate	Plastic TEE-E					
6	Thread plate	Corrosion-resistant steel 1.4306					
7	Set screws	Corrosion-resistant steel 1.4301					
8	Flanged screws	Carbon steel				Corrosion-resistant steel 1.4303	Carbon steel
9	Lube nipple					Corrosion-resistant steel 1.4305	
Item	Component	Ball guide rail					
10	Ball guide rail	Heat-treated steel				Corrosion-resistant steel 1.4116	Heat-treated steel
11	Cover strip	Corrosion-resistant steel 1.4310					
12	Strip clamp	Aluminum, anodized					
13	Clamping screw with nut	Corrosion-resistant steel 1.4301					

Product description

Characteristic features

- ▶ The same high load capacities in all four main directions of loading
- ▶ Low noise level and outstanding travel behavior
- ▶ Excellent dynamic characteristics:
Travel speed: $v_{\max} = 5 \text{ m/s}$
Acceleration: $a_{\max} = 500 \text{ m/s}^2$
- ▶ Long-term lubrication is possible over several years
- ▶ Minimum quantity lubrication system with integrated reservoir for oil lubrication¹⁾
- ▶ Lube fittings with metal threads on all sides¹⁾
- ▶ Limitless interchangeability as all ball guide rail systems can be combined at will with all ball runner block versions within each accuracy class.
- ▶ Maximum system rigidity due to preloaded O-arrangement
- ▶ Optional integrated, inductive and wear-free measuring system
- ▶ First-class logistics unique worldwide thanks to universal interchangeability of the components within any accuracy class
- ▶ Attachments on the ball runner block can be bolted from above and below¹⁾
- ▶ Improved rigidity under lift-off and side loading conditions due to two additional mounting screw bores at the center of the ball runner block¹⁾
- ▶ Wide range of accessories
- ▶ End-face fastening thread for all attachments

Further highlights

- ▶ High rigidity in all directions of loading – permits applications with just one runner block per rail
- ▶ Integrated all-round sealing
- ▶ High torque load capacity
- ▶ Optimized entry-zone geometry and high number of balls minimize variation in elastic deflection
- ▶ Quiet, smooth running thanks to optimally designed ball and ball chain return and guideway
- ▶ Different preload classes
- ▶ Ball runner block pre-lubricated at the factory¹⁾
- ▶ Optionally available with ball chain¹⁾

Corrosion protection (optional)¹⁾

- ▶ Resist NR:
Ball runner block body made of corrosion-resistant steel as per DIN EN 10088
- ▶ Resist NR II:
Ball runner block body and ball guide rail as well as all steel parts made of corrosion-resistant steel in accordance with DIN EN 10088
- ▶ Resist CR:
Ball runner block body or ball guide rail made of steel with corrosion-resistant coating, matte-silver finish, hard chrome plated

1) Type-dependent

Ball rail system with steel ball runner block FNS (components and assembly)

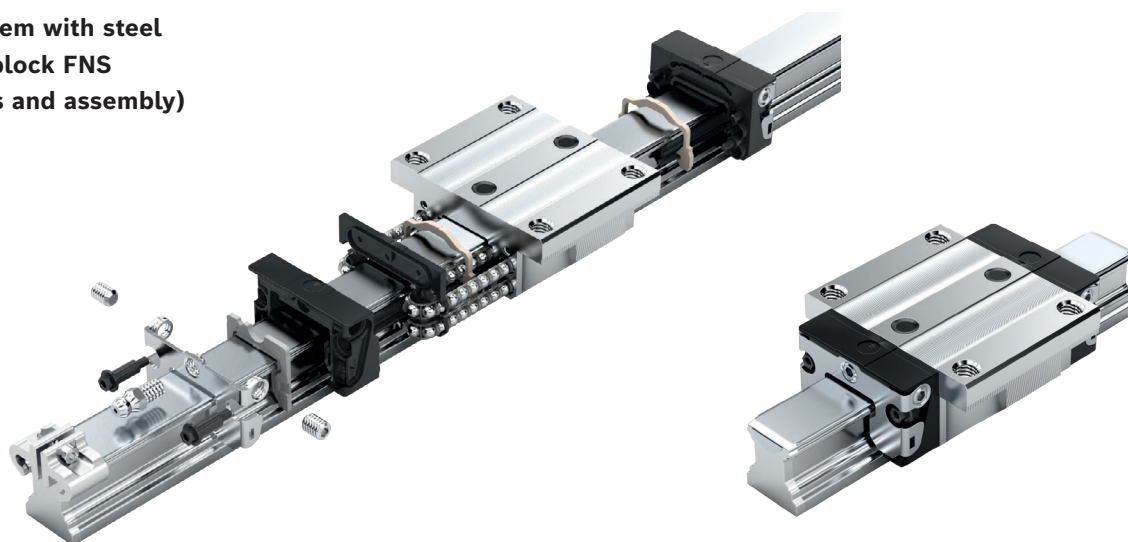

Highlights of the ball runner blocks BSHP

- ▶ Further increased travel accuracy up to a factor of six
- ▶ Significantly reduced frictional oscillations and low friction force level, particularly under external load
- ▶ Maximum precision
- ▶ Selected qualities
- ▶ Minimum quantity preservation in the accuracy classes XP; SP; UP.
(Impairment of the environment is reduced by the preservative agent)
- ▶ Patented entry zone increases the travel accuracy
- ▶ All other advantages of Rexroth precision ball runner blocks integrated

Comparison

Conventional ball runner blocks

If the ball runner block comprises of a conventional entry zone, this may only be designed for a specific load point.

Entry-zone geometry for conventional ball runner blocks

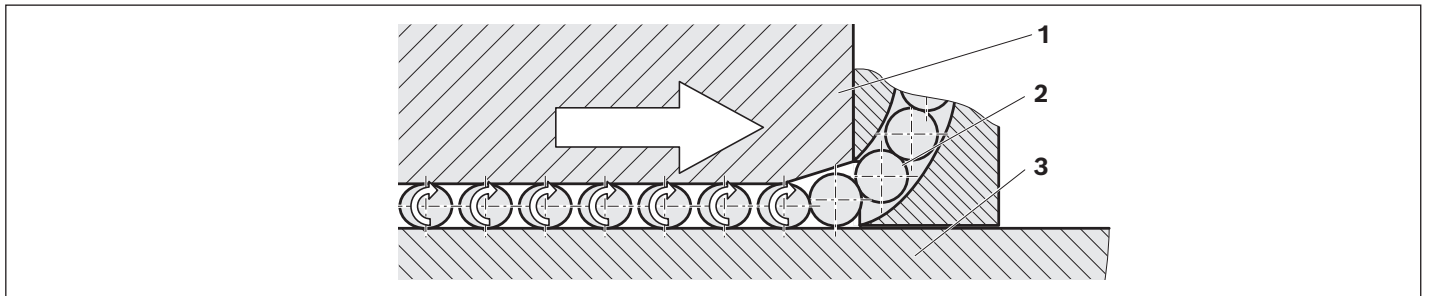

1) Ball runner blocks 2) Ball 3) Ball guide rail

Ball entry

- ▶ The balls are guided up to the start of the entry zone via the roller deflection.
- ▶ If the distance between the ball runner block (1) and the ball guide rail (3) is smaller than the ball diameter, the ball (2) is put under load (preload) in pulses.
- ▶ The preload is increased in the entry zone and reaches its maximum in the load bearing zone. By doing so, the ball transmits its force from the ball runner block to the ball guide rail.
- ▶ Due to the kinematic and geometric relations, a distance between the individual balls is set.

Entry zone

The conventional ball runner blocks comprise of a fix entry zone. The depth of the entry zone shall be suitable for a high load, since a fault-free ball entry is to be guaranteed under very high loads, as well.

- ▶ On the one hand, as many load-bearing balls as possible should be in the ball runner block in order to reach an ideal load-bearing capacity.
⇒ Entry zone as short as possible
- ▶ On the other hand, the load during the entry of the balls should be increased as slowly as possible and thus in a harmonic manner in order to reach the maximum of the geometric travel accuracy.
⇒ Entry zone which is as flat (long) as possible

There is a conflict of aims between short and long entry zones.

Product description

High-precision ball runner block BSHP

New entry-zone geometry for ball runner block in high-precision version

The ball runner blocks in high-precision version comprise of an innovative entry zone. The steel bearing plates are not supported by the ball runner block in the end area and can therefore deform elastically. The entry zone adjusts itself individually to the current operating load of the ball runner block. I.e. the balls run smoothly into the bearing zone without loading pulsations.

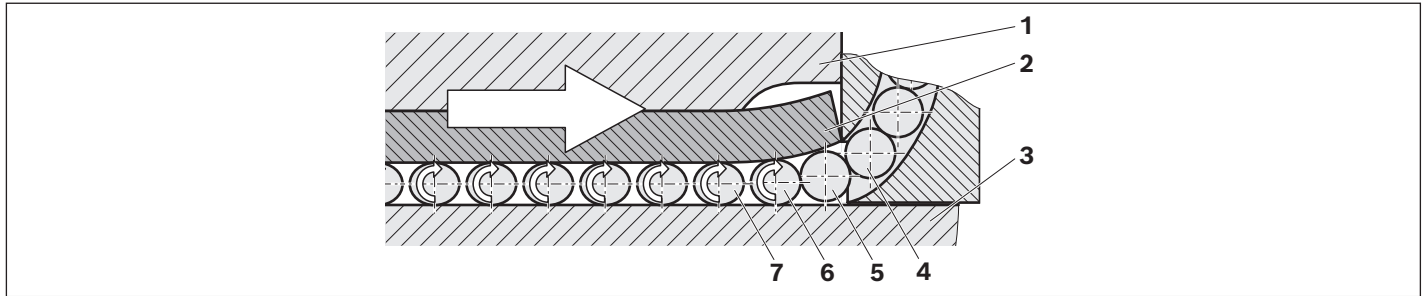

- | | |
|------------------------|--------------------|
| 1) Ball runner block | 3) Ball guide rail |
| 2) Steel bearing plate | 4) – 7) Balls |

Ball entry

- ▶ The balls (4) are guided up to the start of the entry zone via the roller deflection.
- ▶ The ball (5) can enter without load.
- ▶ The ball (6) elastically deforms the end of the steel bearing plate (2). This deformation results from the total yielding of the ball deformation and the deformation of the free ends of the steel bearing plates.
- ▶ If the distance between the steel bearing plate and the ball guide rail (3) is smaller than the ball diameter, the ball is put under load (preload) slowly and evenly.
- ▶ The preload is increased harmonically until the ball (7) has reached its maximum preload.

Innovative solutions by Rexroth:

The load-dependent entry zone

The functionality of the entry zone is decisive. The steel bearing plates are manufactured with such precision that they deflect by the ideal amount according to the load. Thus, the balls can enter particularly smoothly. Due to the precise manufacture of the steel bearing plates, they are only deformed by an entering ball to such an extent that the following ball can run in without load. The balls thus no longer enter the load-bearing zone through a fixed entry zone, rather transition smoothly on a tangential, ideally angled elastic line into the load-bearing zone. The smooth entry of the balls and the continuous adaptation of the entry zone to the load represent the most decisive benefits of the high-precision ball runner blocks.

Characteristic features

- | | |
|---|-------------------------------------|
| 1 | Maximum travel accuracy |
| 2 | Reduced friction force oscillations |
| 3 | The conflict of aims is resolved |

Fluctuation of friction forces

Definition

The overall driving force of a ball runner block consist of the following components:

- 1 Ball friction
- 2 Sealing friction
- 3 Friction in the ball deflections and ball returns

In operation, the fluctuations of the friction force can be particularly disturbing.

These fluctuations are essentially impacted by the following effect:

The balls need to be brought into the loaded load-bearing zone from the load-free zone. The harmonic entry zone and the innovative ball feed are used to reduce the fluctuations to a minimum, which means that the linear drive will also be easier to control.

Friction force comparison of ball runner block size 35 with an external load of 10,000 N

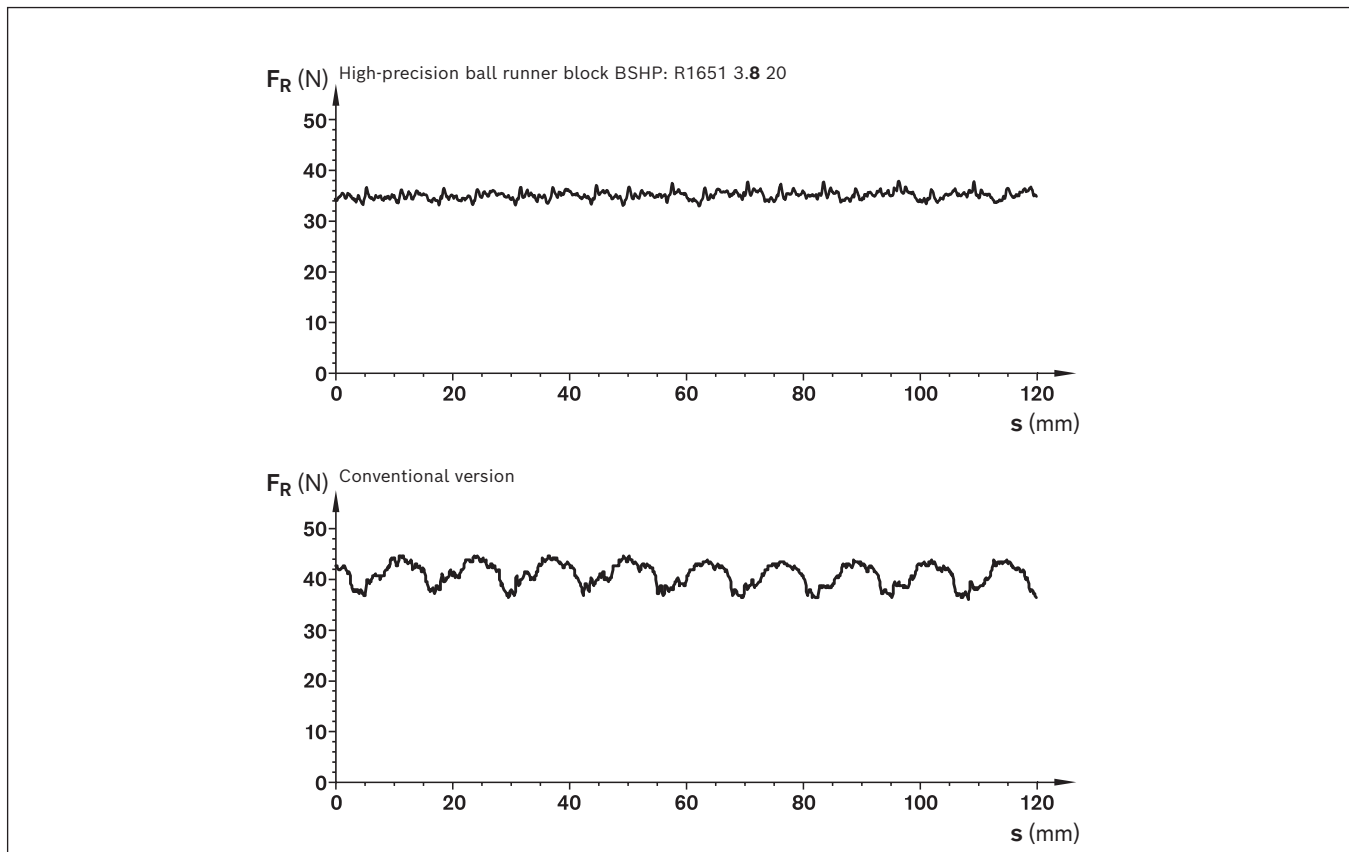

⇒ Reduced friction force value

⇒ Significantly reduced fluctuation of friction forces

Product description

Travel accuracy

Definition

In an ideal case, a ball runner block moves translatively in relation to the x-axis over the ball guide rail. In practice, however, deviations occur in all six degrees of freedom. The term travel accuracy describes the deviation from this ideal line.

Six different degrees of freedom

- 1 Vertical offset (linear deviation in Z)
- 2 Yaw (rotary motion around Z)
- 3 Side deviation (linear deviation in Y)
- 4 Pitching (rotary motion around Y)
- 5 Translation (linear movement in X)
- 6 Rollers (rotary motion around x)

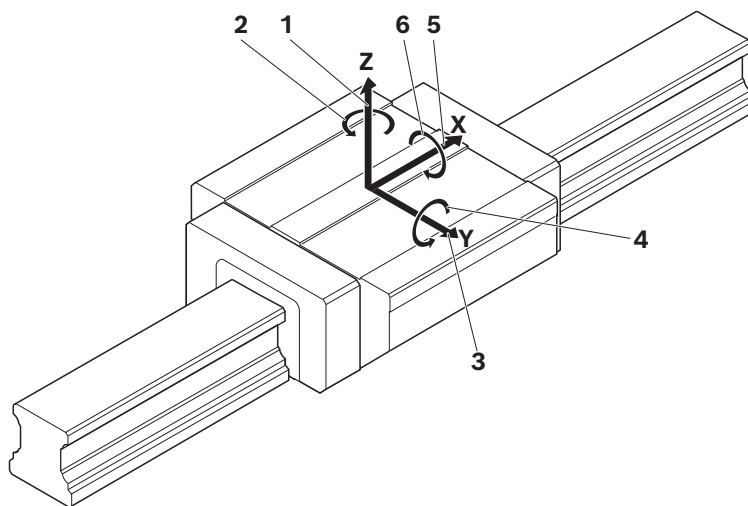

Causes of travel inaccuracy

The travel accuracy is impacted by the following points:

1. Inaccurate mounting base on which the ball guide rail is mounted.
2. Parallelism error between the contact areas of the ball guide rail and the running tracks.
3. Elastic deformations of the ball guide rail by the fastening screws.
4. Accuracy fluctuations caused by the balls entering and exiting.

Potential for optimization

With respect to 1: Contact surfaces of the ball guide rail should be produced as precisely as possible (outside of the scope of influence of Rexroth).

With respect to 2: Any deviation should be equalized by the selection of the accuracy class of the ball guide rail.

With respect to 3: Reduce the tightening torque. The tightening torque of the fastening screws has a proportional impact.

A reduction of the tightening torque decreases the compressive strain of the rail material.

⇒ Lower geometric process fluctuations

With respect to 4: The patented, innovative entry zone of Rexroth - high-precision ball runner blocks reduces the speed fluctuations to a minimum.

⚠ With this measure, the transferable forces and moments can be reduced.

Further potential for improvement:

- ▶ Use of long ball runner blocks
- ▶ Installation of additional ball runner blocks per ball guide rail.

The measured deviations have the following cause

A ball circulation contains a number n of supporting balls which are under load. If the ball runner block is moved into the direction of travel, via the entry zone, a new ball enters the load-bearing zone and $n + 1$ balls are supporting. This disturbs the internal balance of the four supporting rows of balls. The ball runner block enters a rotational movement since the balls can arbitrarily enter the supporting rows of balls. In order to restore the balance, the ball runner block is moving into a new balance position. If the ball runner block is moved further, a supporting ball exits the load-bearing zone at the ball exit. Thus, the internal balance of the four supporting rows of balls is disturbed again and the ball runner block enters a rotational movement.

This effect can be clearly seen in the diagram on the next page.

As it has been verified in practical applications, the period of short-wave inaccuracies roughly corresponds to twice the ball diameter.

The remaining long-wave deviation is caused by the described causes 1, 2 and 3 (inaccurate support, parallelism errors and elastic deformation of the ball guide rail due to the fastening screws).

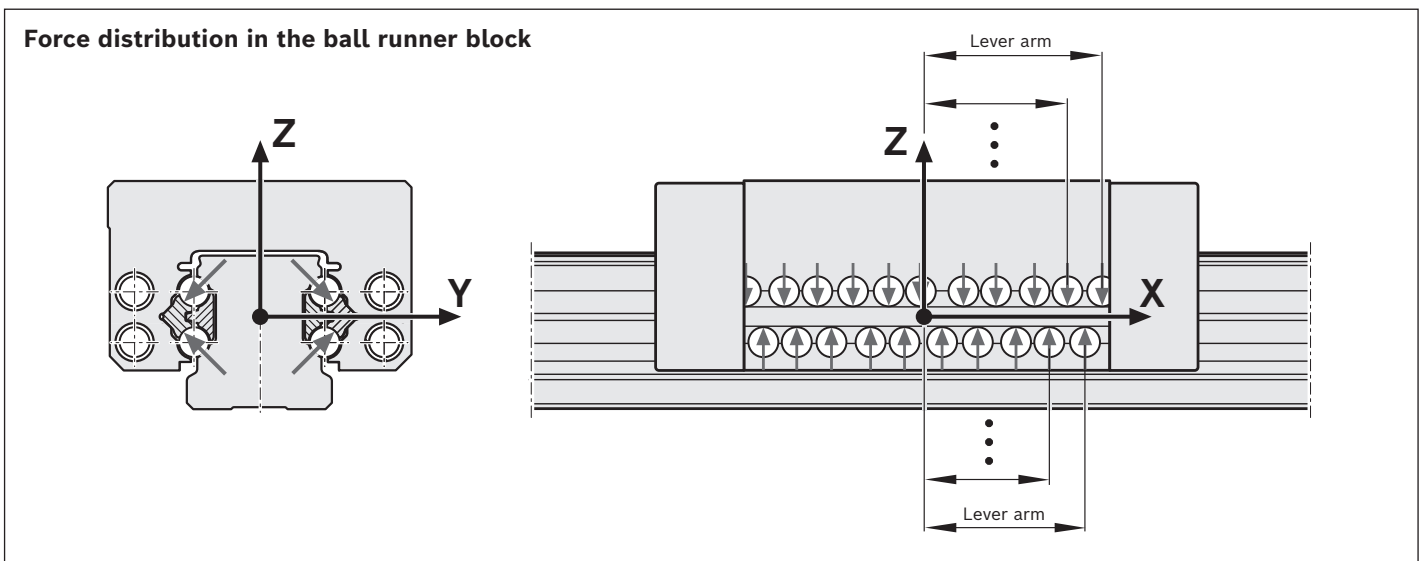

Product description

Direct comparison of the travel accuracy of two ball runner blocks

It can be clearly seen that the short-wave inaccuracy (dashed) can be significantly reduced by the new innovative design of the entry zone (continuous line).

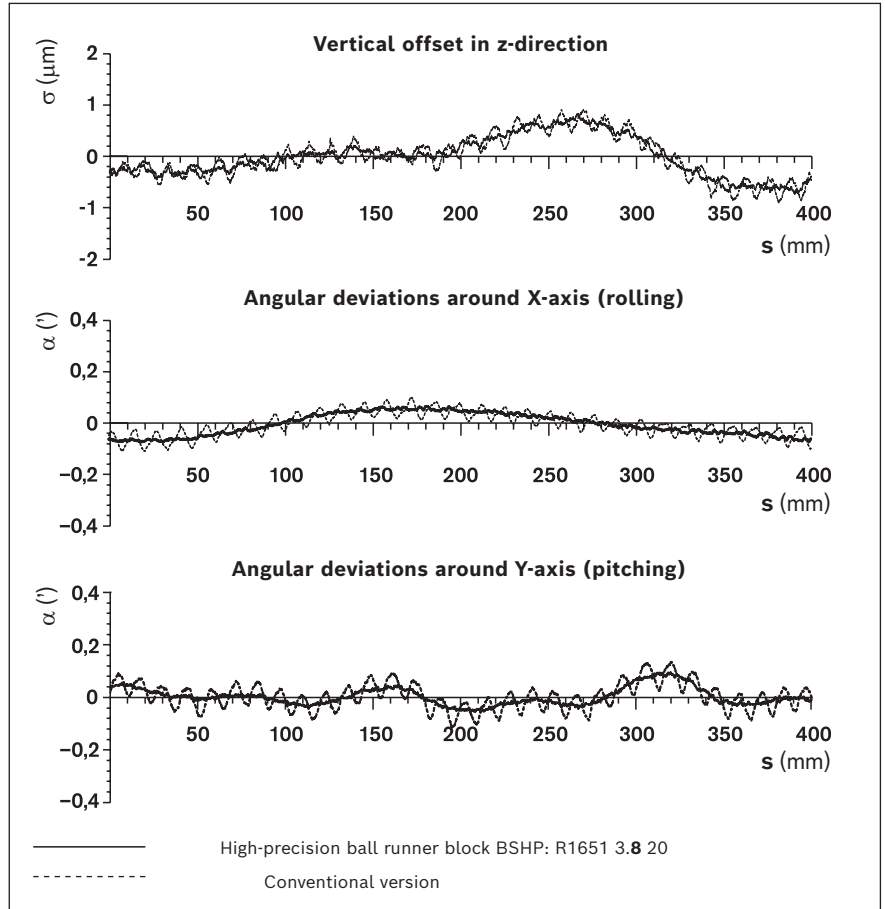

Application examples

Rexroth high-precision ball runner blocks are particularly suited for the following applications:

Measuring

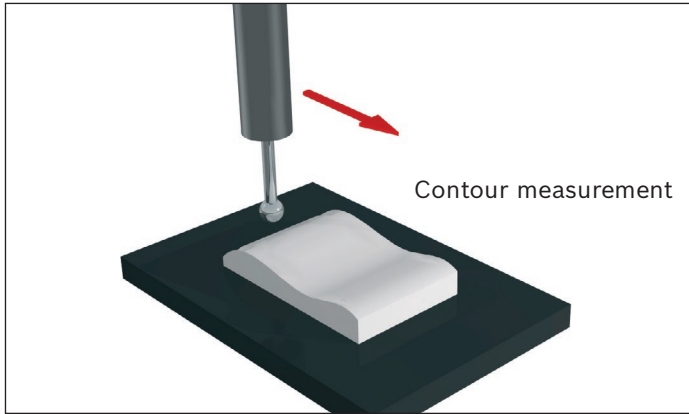

3D coordinate measuring machine

Milling

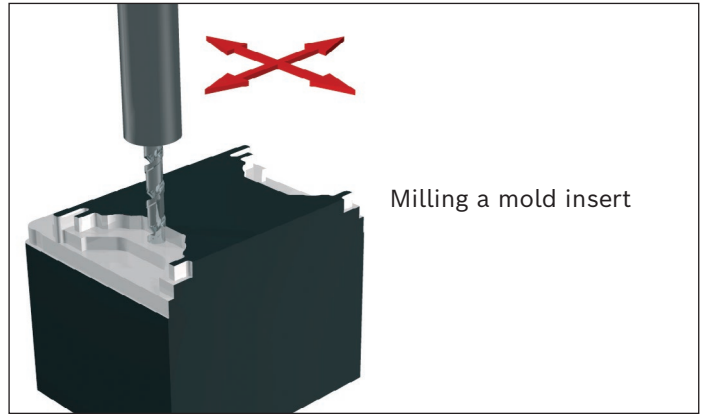

Hard milling

Grinding

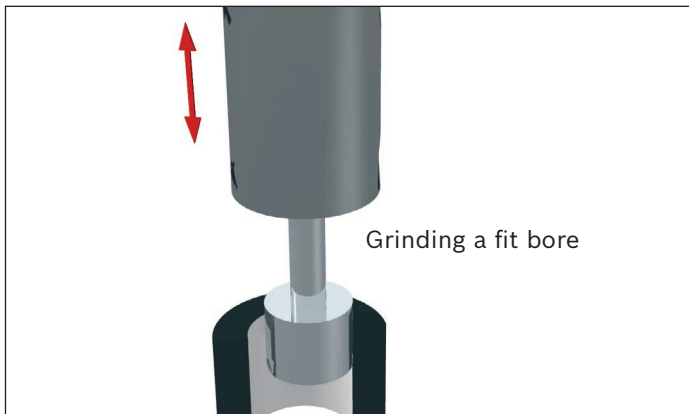

Internal cylindrical grinding

Turning

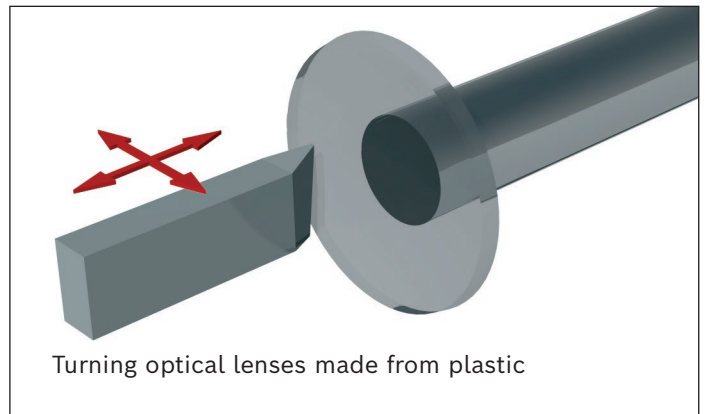

High-precision turning

Electrical discharge machining

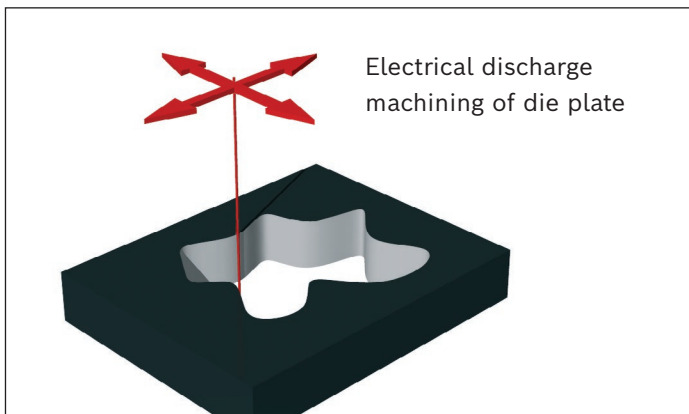

Wire electrical discharge machining

Microelectronics

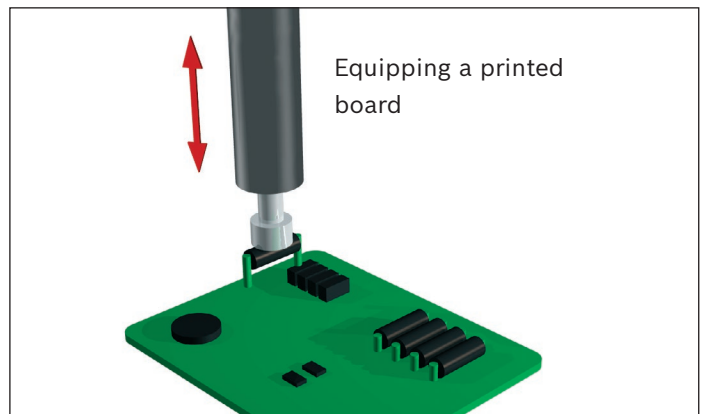

Printed board mounting machine

These are only a few examples. Naturally, other applications can be realized. Feel free to ask any questions that you may have. We have an appropriate solution.

Overview of formats

Standard ball runner blocks¹⁾ BSHP up to size 45

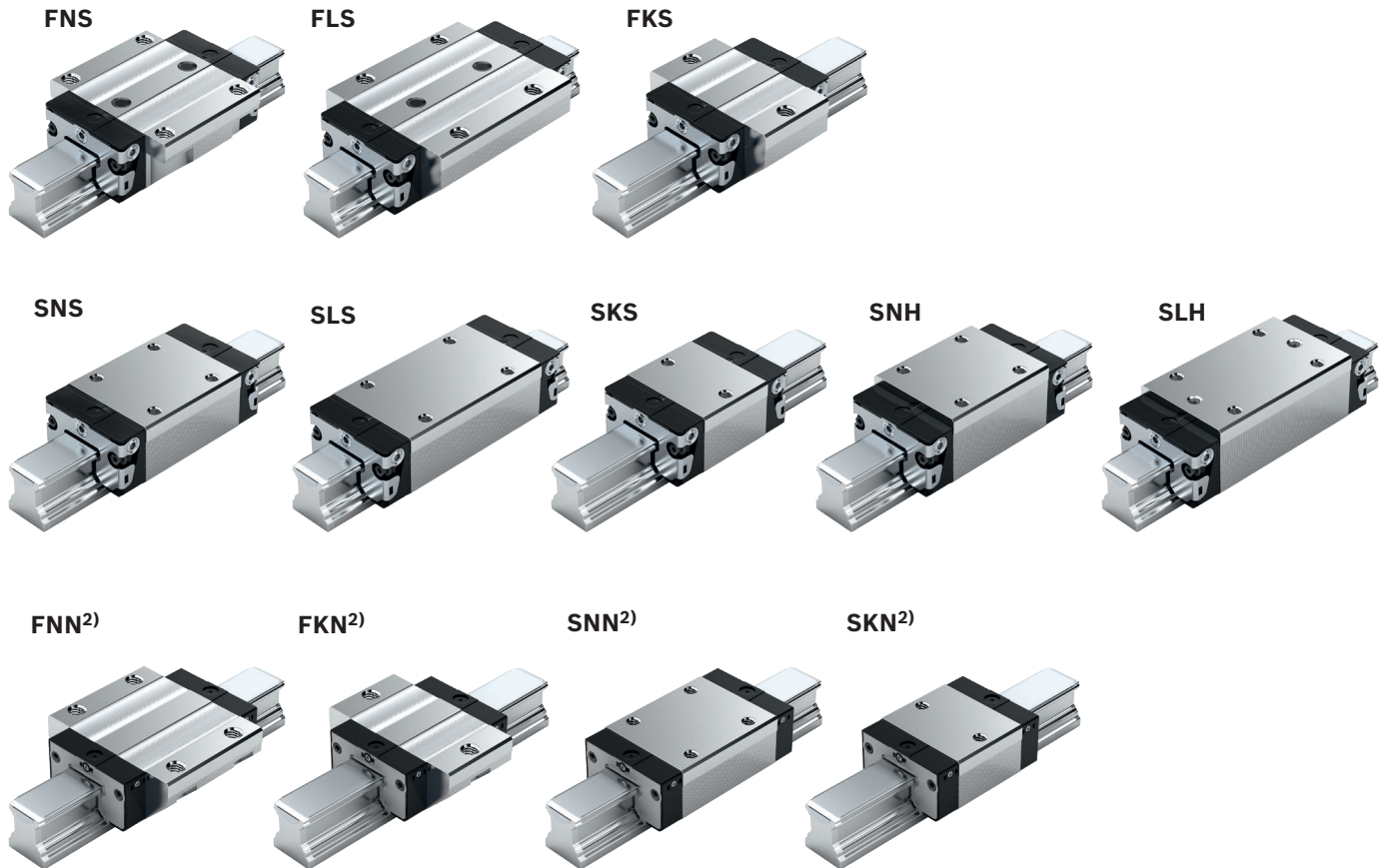

Heavy-duty ball runner blocks²⁾ BSHP from size 55

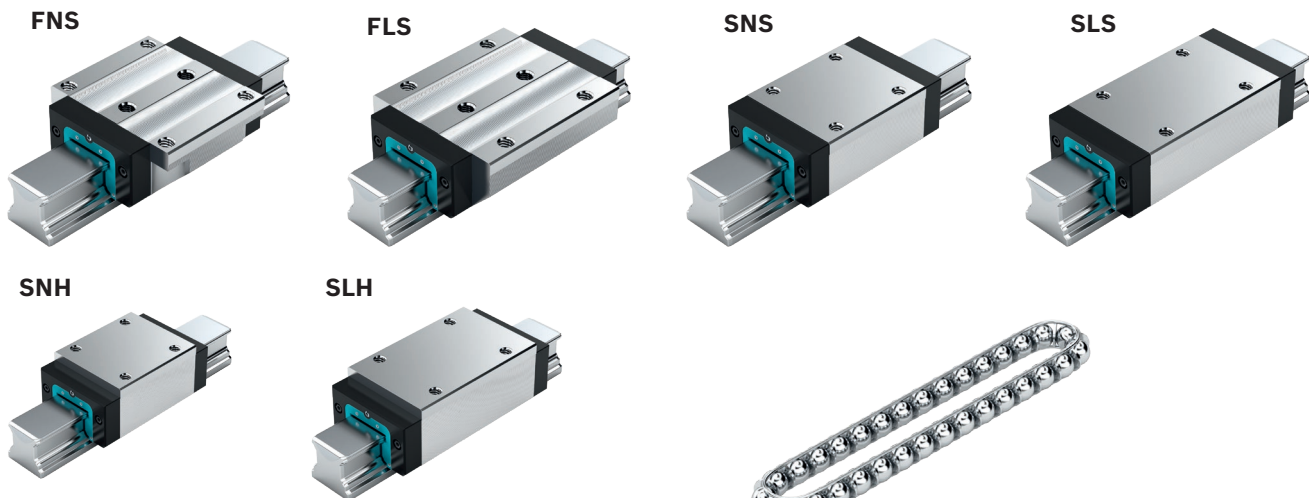

- 1) with ball chain
- 2) Without ball chain



Ball chain (optional)
 ▶ Optimized noise level

FNS – Flange, normal, standard height R1651 ... 2.

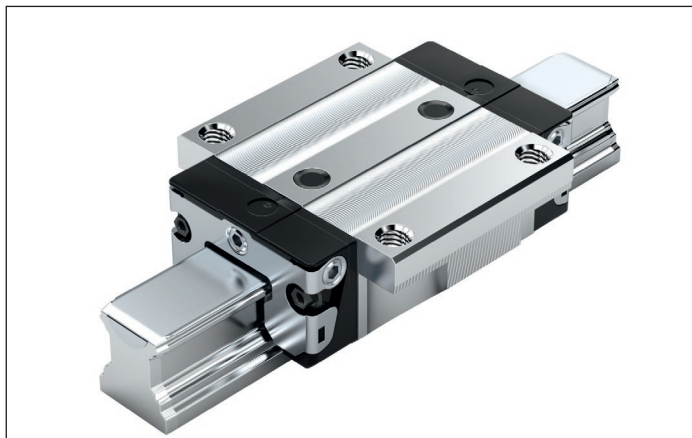

Dynamic characteristics

Speed: $v_{max} = 5 \text{ m/s}$
 Acceleration: $a_{max} = 500 \text{ m/s}^2$
 (If $F_{comb} > 2.8 \cdot F_{pr}$: $a_{max} = 50 \text{ m/s}^2$)

Note on lubrication

► Pre-lubricated

Note

Can be used on all SNS/SNO ball guide rails. Ball runner blocks of size 55 and size 65 can be found in chapter "Heavy-duty ball runner block BSHP made of steel" after this chapter.

Options and material numbers

Size	Ball runner block with size	Preload class				Accuracy class						Seal on ball runner block						
		C0	C1	C2	C3	N	H	P	XP	SP	UP	without ball chain			with ball chain			
												SS	LS ¹⁾	DS	SS	LS ¹⁾	DS	
15	R1651 1	9				4	3	-	-	-	-	20	21	-	22	23	-	
			1			4	3	2	8	1	9	20	21	2Z	22	23	2Y	
				2		-	3	2	8	1	9	20	21	2Z	22	23	2Y	
					3	-	-	-	8	1	9	20	21	2Z	22	23	2Y	
20	R1651 8	9				4	3	-	-	-	-	20	21	-	22	23	-	
			1			4	3	2	8	1	9	20	21	2Z	22	23	2Y	
				2		-	3	2	8	1	9	20	21	2Z	22	23	2Y	
					3	-	-	-	8	1	9	20	21	2Z	22	23	2Y	
25	R1651 2	9				4	3	-	-	-	-	20	21	-	22	23	-	
			1			4	3	2	8	1	9	20	21	2Z	22	23	2Y	
				2		-	3	2	8	1	9	20	21	2Z	22	23	2Y	
					3	-	-	-	8	1	9	20	21	2Z	22	23	2Y	
30	R1651 7	9				4	3	-	-	-	-	20	21	-	22	23	-	
			1			4	3	2	8	1	9	20	21	2Z	22	23	2Y	
				2		-	3	2	8	1	9	20	21	2Z	22	23	2Y	
					3	-	-	-	8	1	9	20	21	2Z	22	23	2Y	
35	R1651 3	9				4	3	-	-	-	-	20	21	-	22	23	-	
			1			4	3	2	8	1	9	20	21	2Z	22	23	2Y	
				2		-	3	2	8	1	9	20	21	2Z	22	23	2Y	
					3	-	-	-	8	1	9	20	21	2Z	22	23	2Y	
45	R1651 4	9				4	3	-	-	-	-	20	-	-	22	-	-	
			1			4	3	2	8	1	9	20	-	-	2Z	22	-	2Y
				2		-	3	2	8	1	9	20	-	-	2Z	22	-	2Y
					3	-	-	-	8	1	9	20	-	-	2Z	22	-	2Y
E.g.:	R1651 7		1				3								20			

1) Only for accuracy classes N and H and for XP in preload class C1.

Ordering example

Options:

- Ball runner block FNS
- Size 30
- Preload class C1
- Accuracy class H
- With standard seal, without ball chain

Material number:

R1651 713 20

Preload classes

C0 = Without preload (clearance)
 C1 = Moderate preload
 C2 = Average preload
 C3 = High preload

Seals

SS = Standard seal
 LS = Low-friction seal
 DS = Double-lip seal

Key

gray numbers
 = no preferred variant / combination
 (partially longer delivery times)

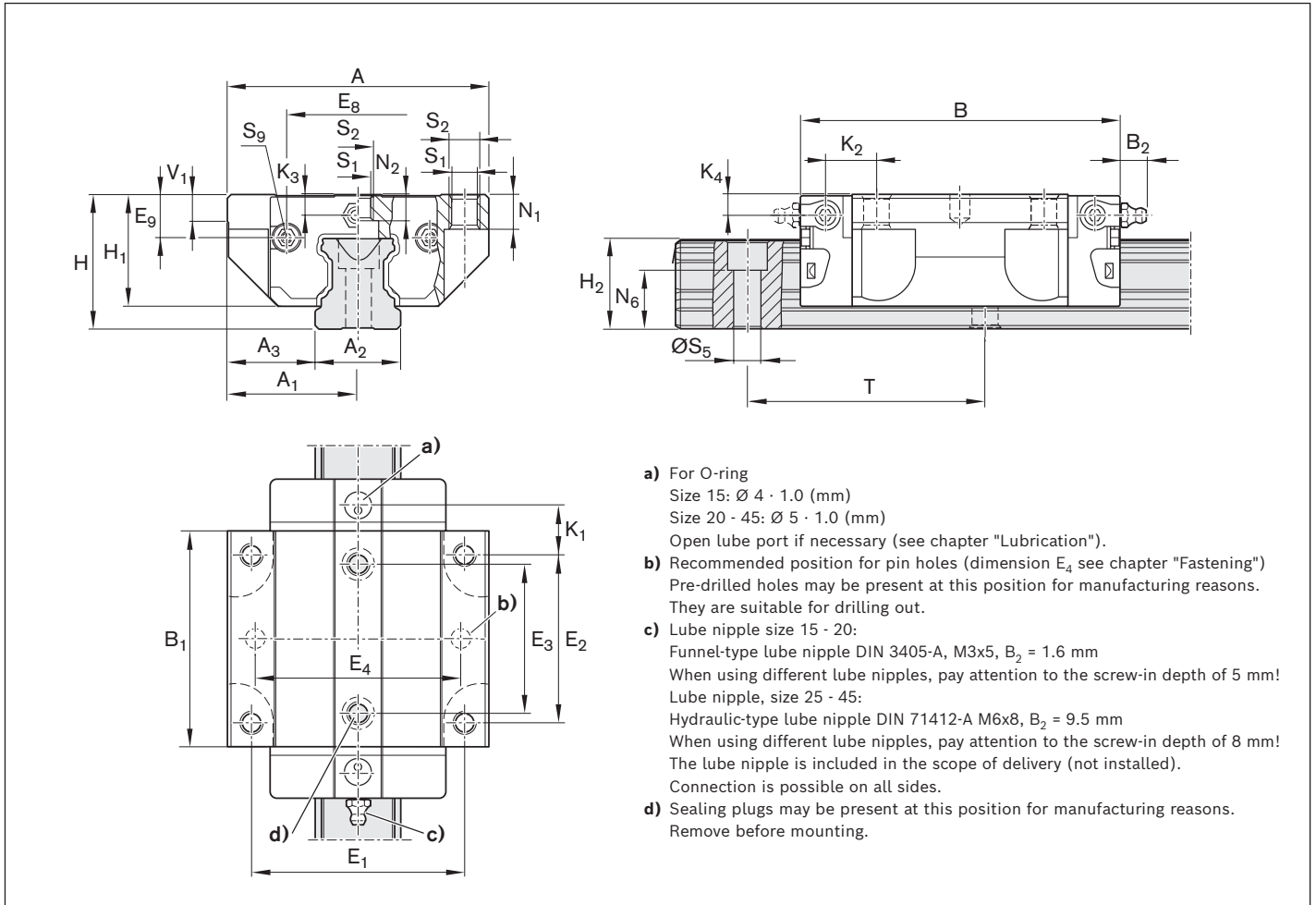

- a) For O-ring
Size 15: $\text{Ø } 4 \cdot 1.0$ (mm)
Size 20 - 45: $\text{Ø } 5 \cdot 1.0$ (mm)
Open lube port if necessary (see chapter "Lubrication").
- b) Recommended position for pin holes (dimension E_4 see chapter "Fastening")
Pre-drilled holes may be present at this position for manufacturing reasons.
They are suitable for drilling out.
- c) Lube nipple size 15 - 20:
Funnel-type lube nipple DIN 3405-A, M3x5, $B_2 = 1.6$ mm
When using different lube nipples, pay attention to the screw-in depth of 5 mm!
Lube nipple, size 25 - 45:
Hydraulic-type lube nipple DIN 71412-A M6x8, $B_2 = 9.5$ mm
When using different lube nipples, pay attention to the screw-in depth of 8 mm!
The lube nipple is included in the scope of delivery (not installed).
Connection is possible on all sides.
- d) Sealing plugs may be present at this position for manufacturing reasons.
Remove before mounting.

Size	Dimensions (mm)																		
	A	A ₁	A ₂	A ₃	B ^{+0.5}	B ₁	E ₁	E ₂	E ₃	E ₈	E ₉	H	H ₁	H ₂ ¹⁾	H ₂ ²⁾	K ₁	K ₂	K ₃	K ₄
15	47	23.5	15	16.0	58.2	39.2	38	30	26	24.55	6.70	24	19.90	16.30	16.20	8.00	9.6	3.20	3.20
20	63	31.5	20	21.5	75.0	49.6	53	40	35	32.50	7.30	30	25.35	20.75	20.55	11.80	11.8	3.35	3.35
25	70	35.0	23	23.5	86.2	57.8	57	45	40	38.30	11.50	36	29.90	24.45	24.25	12.45	13.6	5.50	5.50
30	90	45.0	28	31.0	97.7	67.4	72	52	44	48.40	14.60	42	35.35	28.55	28.35	14.00	15.7	6.05	6.05
35	100	50.0	34	33.0	110.5	77.0	82	62	52	58.00	17.35	48	40.40	32.15	31.85	14.50	16.0	6.90	6.90
45	120	60.0	45	37.5	137.6	97.0	100	80	60	69.80	20.90	60	50.30	40.15	39.85	17.30	19.3	8.20	8.20

Size	Dimensions (mm)										Mass (kg)	Load capacities ³⁾ (N)		Load moments ³⁾ (Nm)			
	N ₁	N ₂	N ₆ ^{±0.5}	S ₁	S ₂	S ₅	S ₉	T	V ₁	m		C	C ₀	M _t	M _{t0}	M _L	M _{L0}
15	5.2	4.40	10.3	4.3	M5	4.5	M2,5x3,5	60	5.0	0.20	9860	12700	95	120	68	87	
20	7.7	5.20	13.2	5.3	M6	6.0	M3x5	60	6.0	0.45	23400	29800	300	380	200	260	
25	9.3	7.00	15.2	6.7	M8	7.0	M3x5	60	7.5	0.65	28600	35900	410	510	290	360	
30	11.0	7.90	17.0	8.5	M10	9.0	M3x5	80	7.0	1.10	36500	48100	630	830	440	580	
35	12.0	10.15	20.5	8.5	M10	9.0	M3x5	80	8.0	1.60	51800	80900	1110	1740	720	1130	
45	15.0	12.40	23.5	10.4	M12	14.0	M4x7	105	10.0	3.00	86400	132000	2330	3560	1540	2350	

- 1) Dimension H₂ with cover strip
- 2) Dimension H₂ without cover strip
- 3) Load capacities and load moments for ball runner block **without** ball chain. Load capacities and load moments for ball runner block **with** ball chain 12

Determination of the dynamic load capacities and load moments is based on a stroke travel of 100,000 m according to DIN ISO 14728-1. Often only 50,000 m are actually stipulated. For comparison: Multiply the values **C**, **M_t** and **M_L** by 1.26 according to the table.

FLS – Flange, long, standard height R1653 ... 2.

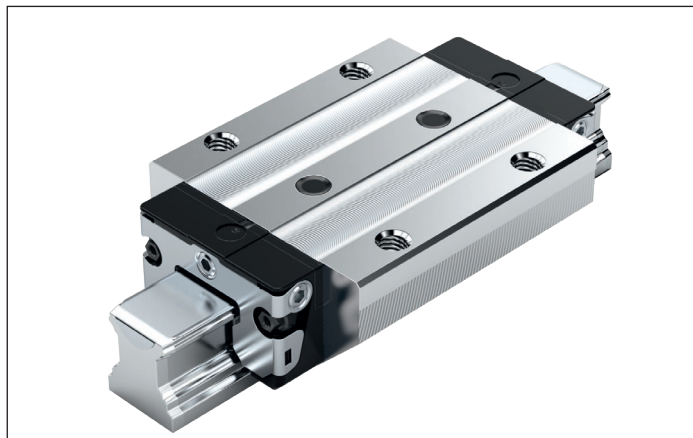

Dynamic characteristics

Speed: $v_{max} = 5 \text{ m/s}$
 Acceleration: $a_{max} = 500 \text{ m/s}^2$
 (If $F_{comb} > 2.8 \cdot F_{pr}$: $a_{max} = 50 \text{ m/s}^2$)

Note on lubrication

► Pre-lubricated

Note

Can be used on all SNS/SNO ball guide rails. Ball runner blocks of size 55 and size 65 can be found in chapter "Heavy-duty ball runner block BSHP made of steel" after this chapter.

Options and material numbers

Size	Ball runner block with size	Preload class				Accuracy class						Seal on ball runner block					
		C0	C1	C2	C3	N	H	P	XP	SP	UP	without ball chain		with ball chain			
												SS	LS ¹⁾	DS	SS	LS ¹⁾	DS
15	R1653 1	9				4	3	-	-	-	-	20	21	-	22	23	-
			1			4	3	2	8	1	9	20	21	2Z	22	23	2Y
				2		-	3	2	8	1	9	20	21	2Z	22	23	2Y
					3	-	-	-	8	1	9	20	21	2Z	22	23	2Y
20	R1653 8	9				4	3	-	-	-	-	20	21	-	22	23	-
			1			4	3	2	8	1	9	20	21	2Z	22	23	2Y
				2		-	3	2	8	1	9	20	21	2Z	22	23	2Y
					3	-	-	-	8	1	9	20	21	2Z	22	23	2Y
25	R1653 2	9				4	3	-	-	-	-	20	21	-	22	23	-
			1			4	3	2	8	1	9	20	21	2Z	22	23	2Y
				2		-	3	2	8	1	9	20	21	2Z	22	23	2Y
					3	-	-	-	8	1	9	20	21	2Z	22	23	2Y
30	R1653 7	9				4	3	-	-	-	-	20	21	-	22	23	-
			1			4	3	2	8	1	9	20	21	2Z	22	23	2Y
				2		-	3	2	8	1	9	20	21	2Z	22	23	2Y
					3	-	-	-	8	1	9	20	21	2Z	22	23	2Y
35	R1653 3	9				4	3	-	-	-	-	20	21	-	22	23	-
			1			4	3	2	8	1	9	20	21	2Z	22	23	2Y
				2		-	3	2	8	1	9	20	21	2Z	22	23	2Y
					3	-	-	-	8	1	9	20	21	2Z	22	23	2Y
45	R1653 4	9				4	3	-	-	-	-	20	-	-	22	-	-
			1			4	3	2	8	1	9	20	-	2Z	22	-	2Y
				2		-	3	2	8	1	9	20	-	2Z	22	-	2Y
					3	-	-	-	8	1	9	20	-	2Z	22	-	2Y
E.g.:	R1653 7		1				3										20

1) Only for accuracy classes N and H and for XP in preload class C1.

Ordering example

Options:

- Ball runner block FLS
- Size 30
- Preload class C1
- Accuracy class H
- With standard seal, without ball chain

Material number:

R1653 713 20

Preload classes

C0 = Without preload (clearance)
 C1 = Moderate preload
 C2 = Average preload
 C3 = High preload

Seals

SS = Standard seal
 LS = Low-friction seal
 DS = Double-lip seal

Key

gray numbers
 = no preferred variant / combination
 (partially longer delivery times)

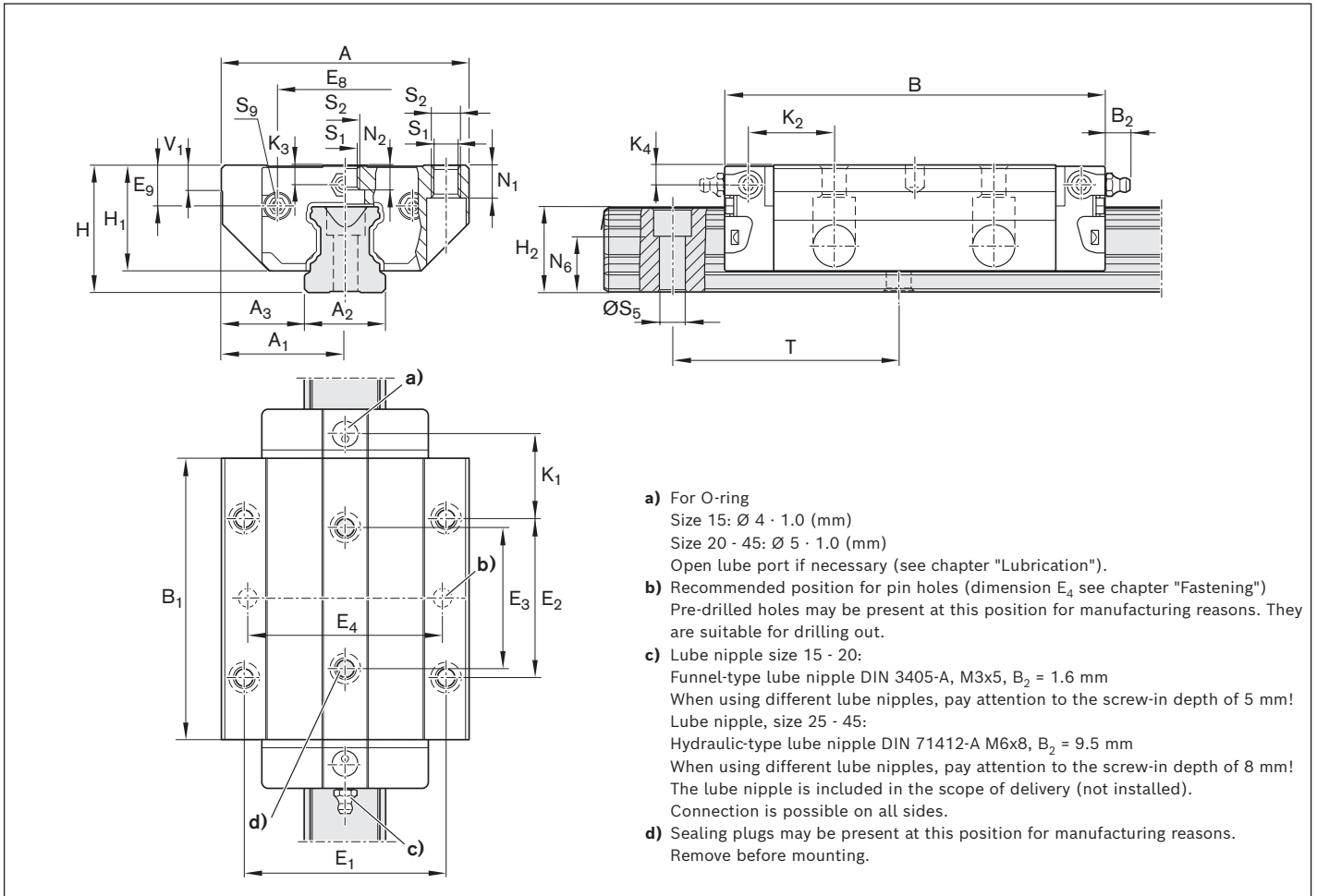

- a) For O-ring
 Size 15: Ø 4 · 1.0 (mm)
 Size 20 - 45: Ø 5 · 1.0 (mm)
 Open lube port if necessary (see chapter "Lubrication").
- b) Recommended position for pin holes (dimension E₄ see chapter "Fastening")
 Pre-drilled holes may be present at this position for manufacturing reasons. They are suitable for drilling out.
- c) Lube nipple size 15 - 20:
 Funnel-type lube nipple DIN 3405-A, M3x5, B₂ = 1.6 mm
 When using different lube nipples, pay attention to the screw-in depth of 5 mm!
 Lube nipple, size 25 - 45:
 Hydraulic-type lube nipple DIN 71412-A M6x8, B₂ = 9.5 mm
 When using different lube nipples, pay attention to the screw-in depth of 8 mm!
 The lube nipple is included in the scope of delivery (not installed).
 Connection is possible on all sides.
- d) Sealing plugs may be present at this position for manufacturing reasons.
 Remove before mounting.

Size	Dimensions (mm)																		
	A	A ₁	A ₂	A ₃	B ^{+0.5}	B ₁	E ₁	E ₂	E ₃	E ₈	E ₉	H	H ₁	H ₂ ¹⁾	H ₂ ²⁾	K ₁	K ₂	K ₃	K ₄
15	47	23.5	15	16.0	72.6	53.6	38	30	26	24.55	6.70	24	19.90	16.30	16.20	15.20	16.80	3.20	3.20
20	63	31.5	20	21.5	91.0	65.6	53	40	35	32.50	7.30	30	25.35	20.75	20.55	19.80	19.80	3.35	3.35
25	70	35.0	23	23.5	107.9	79.5	57	45	40	38.30	11.50	36	29.90	24.45	24.25	23.30	24.45	5.50	5.50
30	90	45.0	28	31.0	119.7	89.4	72	52	44	48.40	14.60	42	35.35	28.55	28.35	25.00	26.70	6.05	6.05
35	100	50.0	34	33.0	139.0	105.5	82	62	52	58.00	17.35	48	40.40	32.15	31.85	28.75	30.25	6.90	6.90
45	120	60.0	45	37.5	174.1	133.5	100	80	60	69.80	20.90	60	50.30	40.15	39.85	35.50	37.50	8.20	8.20

Size	Dimensions (mm)										Mass (kg)	Load capacities ³⁾ (N)		Load moments ³⁾ (Nm)			
	N ₁	N ₂	N ₆ ^{±0.5}	S ₁	S ₂	S ₅	S ₉	T	V ₁	m		C	C ₀	M _t	M ₁₀	M _L	M _{L0}
15	5.2	4.40	10.3	4.3	M5	4.5	M2,5x3,5	60	5.0	0.30	12800	18400	120	180	120	180	
20	7.7	5.20	13.2	5.3	M6	6.0	M3x5	60	6.0	0.55	29600	41800	380	540	340	490	
25	9.3	7.00	15.2	6.7	M8	7.0	M3x5	60	7.5	0.90	37300	52500	530	750	530	740	
30	11.0	7.90	17.0	8.5	M10	9.0	M3x5	80	7.0	1.50	46000	66900	800	1160	740	1080	
35	12.0	10.15	20.5	8.5	M10	9.0	M3x5	80	8.0	2.25	66700	116000	1440	2500	1290	2240	
45	15.0	12.40	23.5	10.4	M12	14.0	M4x7	105	10.0	4.30	111000	190000	3010	5120	2730	4660	

- 1) Dimension H₂ with cover strip
- 2) Dimension H₂ without cover strip
- 3) Load capacities and load moments for ball runner block **without** ball chain. Load capacities and load moments for ball runner block **with** ball chain 12

Determination of the dynamic load capacities and load moments is based on a stroke travel of 100,000 m according to DIN ISO 14728-1. Often only 50,000 m are actually stipulated. For comparison: Multiply the values **C**, **M_t** and **M_L** by 1.26 according to the table.

FKS – Flange, short, standard height R1665 ... 2.

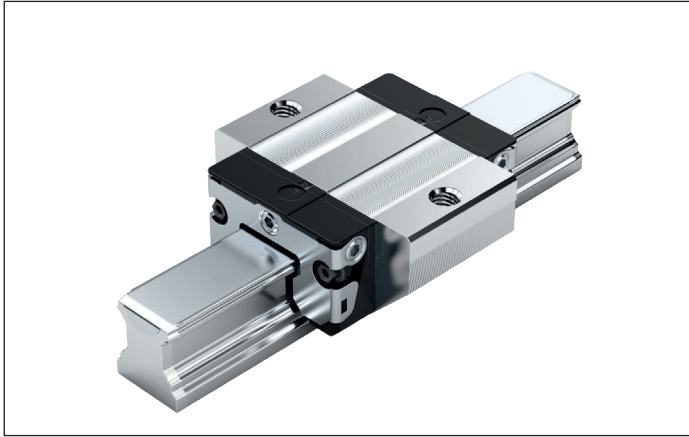

Dynamic characteristics

Speed: $v_{\max} = 5 \text{ m/s}$
 Acceleration: $a_{\max} = 500 \text{ m/s}^2$
 (If $F_{\text{comb}} > 2.8 \cdot F_{\text{pr}}$: $a_{\max} = 50 \text{ m/s}^2$)

Note on lubrication

► Pre-lubricated

Note

Can be used on all SNS/SNO ball guide rails.

Options and material numbers

Size	Ball runner block with size	Preload class		Accuracy class		Seal on ball runner block					
		C0	C1	N	H	without ball chain			with ball chain		
						SS	LS	DS	SS	LS	DS
15	R1665 1	9		4	3	20	21	–	22	23	–
			1	4	3	20	21	2Z	22	23	2Y
20	R1665 8	9		4	3	20	21	–	22	23	–
			1	4	3	20	21	2Z	22	23	2Y
25	R1665 2	9		4	3	20	21	–	22	23	–
			1	4	3	20	21	2Z	22	23	2Y
30	R1665 7	9		4	3	20	21	–	22	23	–
			1	4	3	20	21	2Z	22	23	2Y
35	R1665 3	9		4	3	20	21	–	22	23	–
			1	4	3	20	21	2Z	22	23	2Y
E.g.:	R1665 7		1		3	20					

Ordering example

Options:

- Ball runner block FKS
- Size 30
- Preload class C1
- Accuracy class H
- With standard seal, without ball chain

Material number:

R1665 713 20

Preload classes

C0 = Without preload (clearance)
 C1 = Moderate preload

Seals

SS = Standard seal
 LS = Low-friction seal
 DS = Double-lip seal

Key

gray numbers
 = no preferred variant / combination
 (partially longer delivery times)

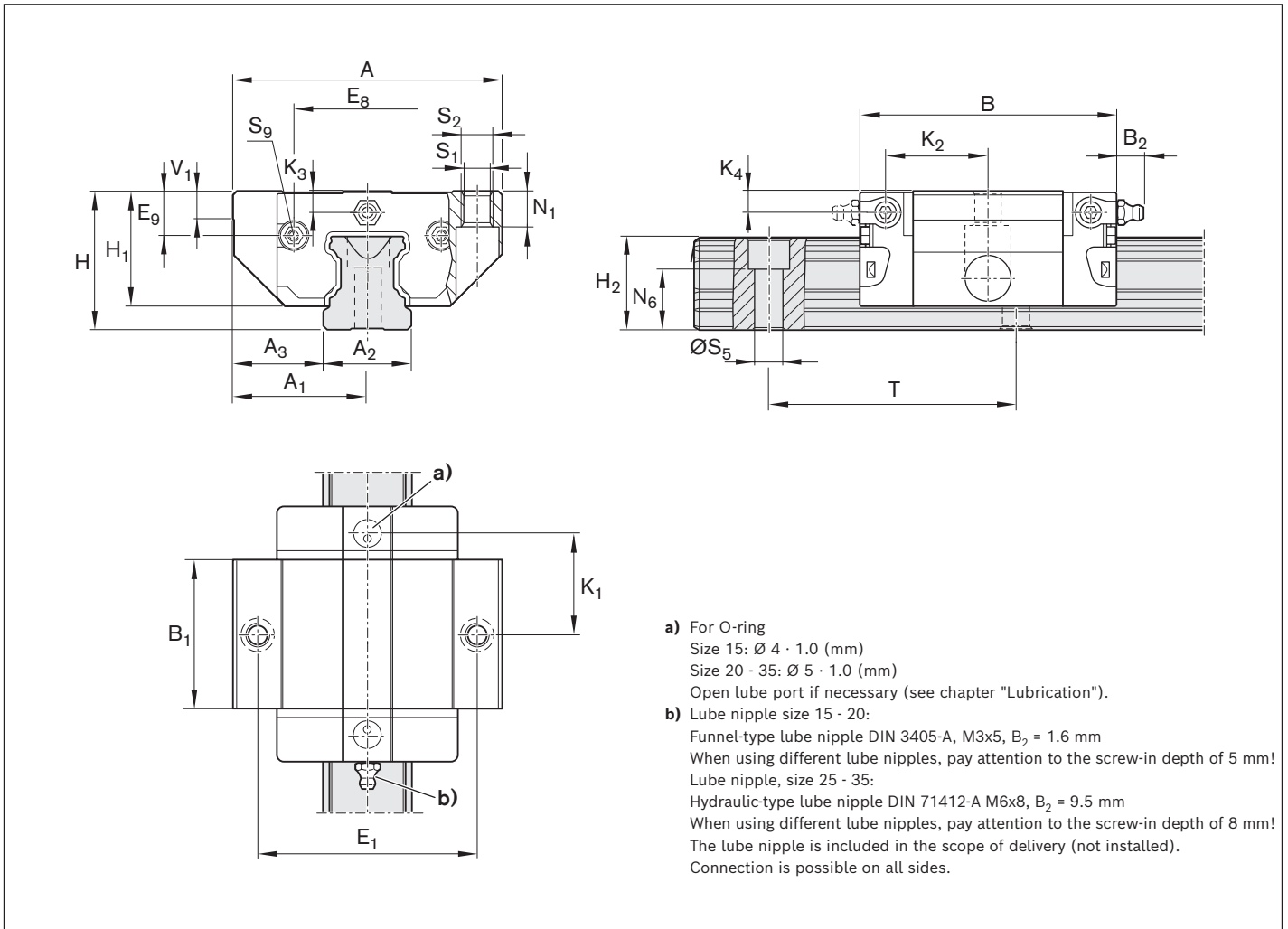

Size	Dimensions (mm)																	
	A	A ₁	A ₂	A ₃	B ^{+0.5}	B ₁	E ₁	E ₈	E ₉	H	H ₁	H ₂ ¹⁾	H ₂ ²⁾	K ₁	K ₂	K ₃	K ₄	
15	47	23.5	15	16.0	44.7	25.7	38	24.55	6.70	24	19.90	16.30	16.20	16.25	17.85	3.20	3.20	
20	63	31.5	20	21.5	57.3	31.9	53	32.50	7.30	30	25.35	20.75	20.55	22.95	22.95	3.35	3.35	
25	70	35.0	23	23.5	67.0	38.6	57	38.30	11.50	36	29.90	24.45	24.25	25.35	26.50	5.50	5.50	
30	90	45.0	28	31.0	75.3	45.0	72	48.40	14.60	42	35.35	28.55	28.35	28.80	30.50	6.05	6.05	
35	100	50.0	34	33.0	84.9	51.4	82	58.00	17.35	48	40.40	32.15	31.85	32.70	34.20	6.90	6.90	

Size	Dimensions (mm)									Mass (kg)	Load capacities ³⁾ (N)		Load moments ³⁾ (Nm)			
	N ₁	N ₆ ^{±0.5}	S ₁	S ₂	S ₅	S ₉	T	V ₁	m		C	C ₀	M _t	M _{t0}	M _L	M _{L0}
15	5.2	10.3	4.3	M5	4.5	M2,5x3,5	60	5.0	0.15	6720	7340	65	71	29	32	
20	7.7	13.2	5.3	M6	6.0	M3x5	60	6.0	0.30	15400	16500	200	210	83	89	
25	9.3	15.2	6.7	M8	7.0	M3x5	60	7.5	0.50	19800	21200	280	300	130	140	
30	11.0	17.0	8.5	M10	9.0	M3x5	80	7.0	0.80	25600	28900	440	500	200	230	
35	12.0	20.5	8.5	M10	9.0	M3x5	80	8.0	1.20	36600	49300	790	1060	340	460	

- 1) Dimension H₂ with cover strip
- 2) Dimension H₂ without cover strip
- 3) Load capacities and load moments for ball runner block **without** ball chain. Load capacities and load moments for ball runner block **with** ball chain 12

Determination of the dynamic load capacities and load moments is based on a stroke travel of 100,000 m according to DIN ISO 14728-1. Often only 50,000 m are actually stipulated. For comparison: Multiply the values **C**, **M_t** and **M_L** by 1.26 according to the table.

SNS – Slimline, normal, standard height R1622 ... 2.

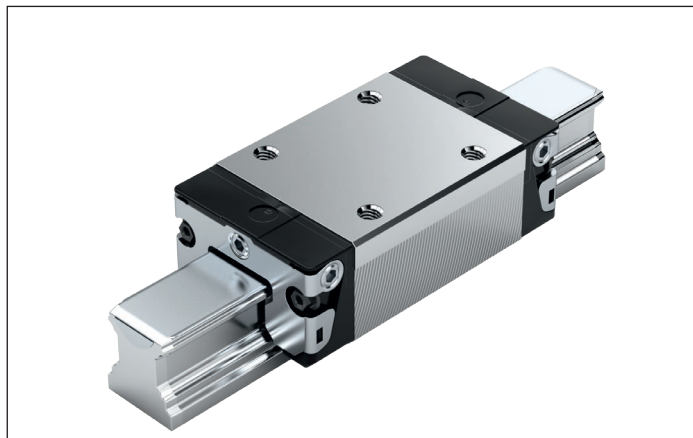

Dynamic characteristics

Speed: $v_{max} = 5 \text{ m/s}$
 Acceleration: $a_{max} = 500 \text{ m/s}^2$
 (If $F_{comb} > 2.8 \cdot F_{pr}$: $a_{max} = 50 \text{ m/s}^2$)

Note on lubrication

► Pre-lubricated

Note

Can be used on all SNS/SNO ball guide rails. Ball runner blocks of size 55 and size 65 can be found in chapter "Heavy-duty ball runner block BSHP made of steel" after this chapter.

Options and material numbers

Size	Ball runner block with size	Preload class				Accuracy class				Seal on ball runner block						
		C0	C1	C2	C3	N	H	P	XP	without ball chain			with ball chain			
										SS	LS ¹⁾	DS	SS	LS ¹⁾	DS	
15	R1622 1	9				4	3	-	-	20	21	-	22	23	-	-
			1			4	3	2	8	20	21	2Z	22	23	2Y	-
				2		-	3	2	8	20	21	2Z	22	23	2Y	-
					3	-	-	-	8	20	21	2Z	22	23	2Y	-
20	R1622 8	9				4	3	-	-	20	21	-	22	23	-	-
			1			4	3	2	8	20	21	2Z	22	23	2Y	-
				2		-	3	2	8	20	21	2Z	22	23	2Y	-
					3	-	-	-	8	20	21	2Z	22	23	2Y	-
25	R1622 2	9				4	3	-	-	20	21	-	22	23	-	-
			1			4	3	2	8	20	21	2Z	22	23	2Y	-
				2		-	3	2	8	20	21	2Z	22	23	2Y	-
					3	-	-	-	8	20	21	2Z	22	23	2Y	-
30	R1622 7	9				4	3	-	-	20	21	-	22	23	-	-
			1			4	3	2	8	20	21	2Z	22	23	2Y	-
				2		-	3	2	8	20	21	2Z	22	23	2Y	-
					3	-	-	-	8	20	21	2Z	22	23	2Y	-
35	R1622 3	9				4	3	-	-	20	21	-	22	23	-	-
			1			4	3	2	8	20	21	2Z	22	23	2Y	-
				2		-	3	2	8	20	21	2Z	22	23	2Y	-
					3	-	-	-	8	20	21	2Z	22	23	2Y	-
45	R1622 4	9				4	3	-	-	20	-	-	22	-	-	-
			1			4	3	2	8	20	-	2Z	22	-	2Y	-
				2		-	3	2	8	20	-	2Z	22	-	2Y	-
					3	-	-	-	8	20	-	2Z	22	-	2Y	-
E.g.:	R1622 7		1			3				20						

1) Only for accuracy classes N and H and for XP in preload class C1.

Ordering example

Options:

- Ball runner block SNS
- Size 30
- Preload class C1
- Accuracy class H
- With standard seal, without ball chain

Material number:

R1622 713 20

Preload classes

C0 = Without preload (clearance)
 C1 = Moderate preload
 C2 = Average preload
 C3 = High preload

Seals

SS = Standard seal
 LS = Low-friction seal
 DS = Double-lip seal

Key

gray numbers
 = no preferred variant / combination
 (partially longer delivery times)

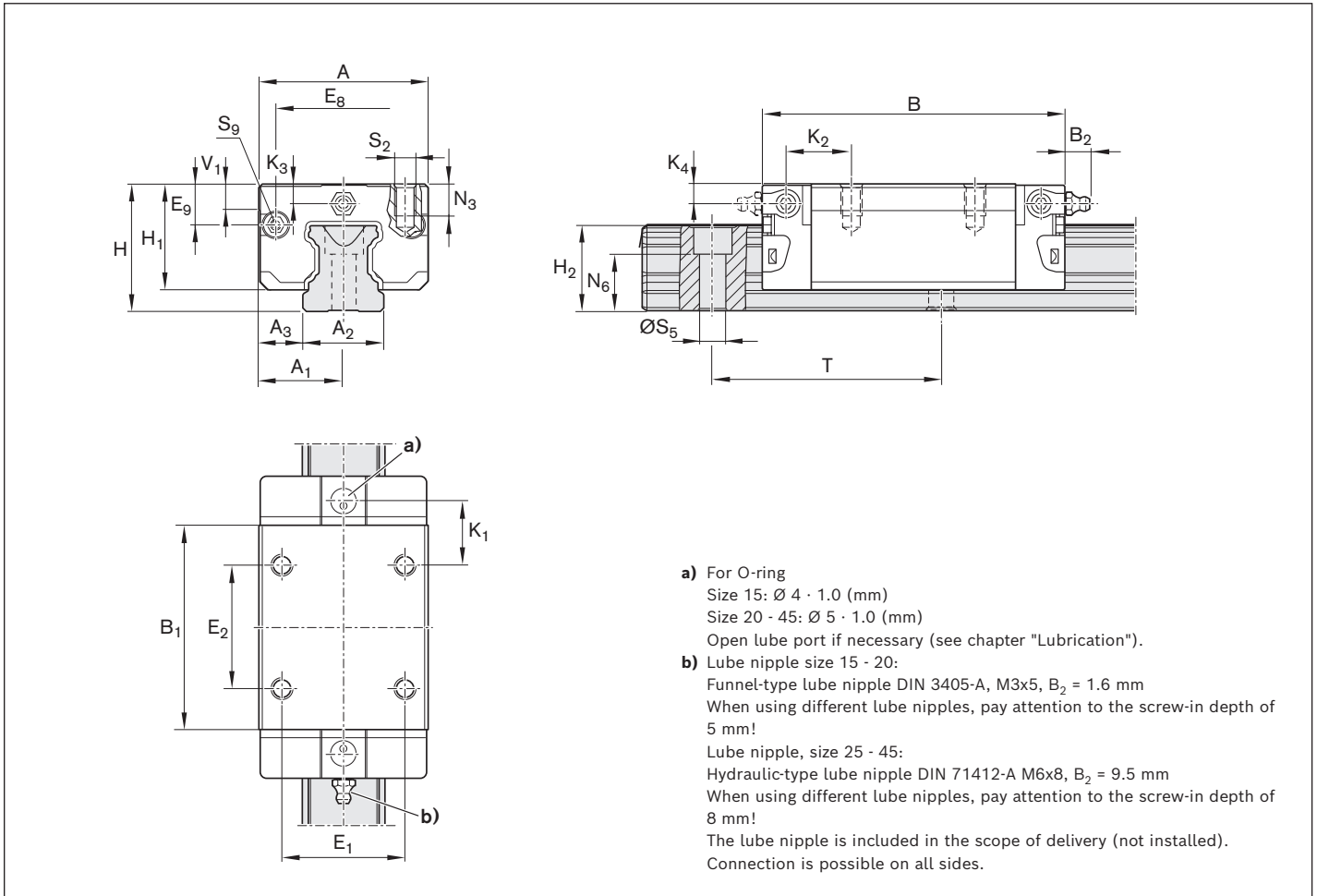

Size	Dimensions (mm)																	
	A	A ₁	A ₂	A ₃	B ^{+0.5}	B ₁	E ₁	E ₂	E ₈	E ₉	H	H ₁	H ₂ ¹⁾	H ₂ ²⁾	K ₁	K ₂	K ₃	K ₄
15	34	17	15	9.5	58.2	39.2	26	26	24.55	6.70	24	19.90	16.30	16.20	10.00	11.60	3.20	3.20
20	44	22	20	12.0	75.0	49.6	32	36	32.50	7.30	30	25.35	20.75	20.55	13.80	13.80	3.35	3.35
25	48	24	23	12.5	86.2	57.8	35	35	38.30	11.50	36	29.90	24.45	24.25	17.45	18.60	5.50	5.50
30	60	30	28	16.0	97.7	67.4	40	40	48.40	14.60	42	35.35	28.55	28.35	20.00	21.70	6.05	6.05
35	70	35	34	18.0	110.5	77.0	50	50	58.00	17.35	48	40.40	32.15	31.85	20.50	22.00	6.90	6.90
45	86	43	45	20.5	137.6	97.0	60	60	69.80	20.90	60	50.30	40.15	39.85	27.30	29.30	8.20	8.20

Size	Dimensions (mm)								Mass (kg)	Load capacities ³⁾ (N)		Load moments ³⁾ (Nm)			
	N ₃	N ₆ ^{±0.5}	S ₂	S ₅	S ₉	T	V ₁	m		C	C ₀	M _t	M _{t0}	M _L	M _{L0}
15	6.0	10.3	M4	4.5	M2,5x3,5	60	5.0	0.15	9860	12700	95	120	68	87	
20	7.5	13.2	M5	6.0	M3x5	60	6.0	0.35	23400	29800	300	380	200	260	
25	9.0	15.2	M6	7.0	M3x5	60	7.5	0.50	28600	35900	410	510	290	360	
30	12.0	17.0	M8	9.0	M3x5	80	7.0	0.85	36500	48100	630	830	440	580	
35	13.0	20.5	M8	9.0	M3x5	80	8.0	1.25	51800	80900	1110	1740	720	1130	
45	18.0	23.5	M10	14.0	M4x7	105	10.0	2.40	86400	132000	2330	3560	1540	2350	

- 1) Dimension H₂ with cover strip
- 2) Dimension H₂ without cover strip
- 3) Load capacities and load moments for ball runner block **without** ball chain. Load capacities and load moments for ball runner block **with** ball chain 12

Determination of the dynamic load capacities and load moments is based on a stroke travel of 100,000 m according to DIN ISO 14728-1. Often only 50,000 m are actually stipulated. For comparison: Multiply the values **C**, **M_t** and **M_L** by 1.26 according to the table.

SLS – Slimline, long, standard height R1623 ... 2.

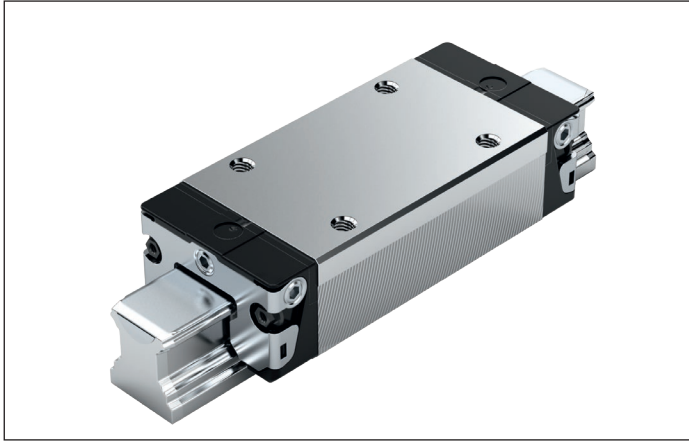

Dynamic characteristics

Speed: $v_{max} = 5 \text{ m/s}$
 Acceleration: $a_{max} = 500 \text{ m/s}^2$
 (If $F_{comb} > 2.8 \cdot F_{pr}$: $a_{max} = 50 \text{ m/s}^2$)

Note on lubrication

► Pre-lubricated

Note

Can be used on all SNS/SNO ball guide rails. Ball runner blocks of size 55 and size 65 can be found in chapter "Heavy-duty ball runner block BSHP made of steel" after this chapter.

Options and material numbers

Size	Ball runner block with size	Preload class				Accuracy class				Seal on ball runner block					
		C0	C1	C2	C3	N	H	P	XP	without ball chain			with ball chain		
										SS	LS ¹⁾	DS	SS	LS ¹⁾	DS
15	R1623 1	9				4	3	–	–	20	21	–	22	23	–
			1			4	3	2	8	20	21	2Z	22	23	2Y
				2		–	3	2	8	20	21	2Z	22	23	2Y
					3	–	–	–	8	20	21	2Z	22	23	2Y
20	R1623 8	9				4	3	–	–	20	21	–	22	23	–
			1			4	3	2	8	20	21	2Z	22	23	2Y
				2		–	3	2	8	20	21	2Z	22	23	2Y
					3	–	–	–	8	20	21	2Z	22	23	2Y
25	R1623 2	9				4	3	–	–	20	21	–	22	23	–
			1			4	3	2	8	20	21	2Z	22	23	2Y
				2		–	3	2	8	20	21	2Z	22	23	2Y
					3	–	–	–	8	20	21	2Z	22	23	2Y
30	R1623 7	9				4	3	–	–	20	21	–	22	23	–
			1			4	3	2	8	20	21	2Z	22	23	2Y
				2		–	3	2	8	20	21	2Z	22	23	2Y
					3	–	–	–	8	20	21	2Z	22	23	2Y
35	R1623 3	9				4	3	–	–	20	21	–	22	23	–
			1			4	3	2	8	20	21	2Z	22	23	2Y
				2		–	3	2	8	20	21	2Z	22	23	2Y
					3	–	–	–	8	20	21	2Z	22	23	2Y
45	R1623 4	9				4	3	–	–	20	–	–	22	–	–
			1			4	3	2	8	20	–	2Z	22	–	2Y
				2		–	3	2	8	20	–	2Z	22	–	2Y
					3	–	–	–	8	20	–	2Z	22	–	2Y
E.g.:	R1623 7		1				3			20					

1) Only for accuracy classes N and H and for XP in preload class C1.

Ordering example

Options:

- Ball runner block SLS
- Size 30
- Preload class C1
- Accuracy class H
- With standard seal, without ball chain

Material number:

R1623 713 20

Preload classes

C0 = Without preload (clearance)
 C1 = Moderate preload
 C2 = Average preload
 C3 = High preload

Seals

SS = Standard seal
 LS = Low-friction seal
 DS = Double-lip seal

Key

gray numbers
 = no preferred variant / combination
 (partially longer delivery times)

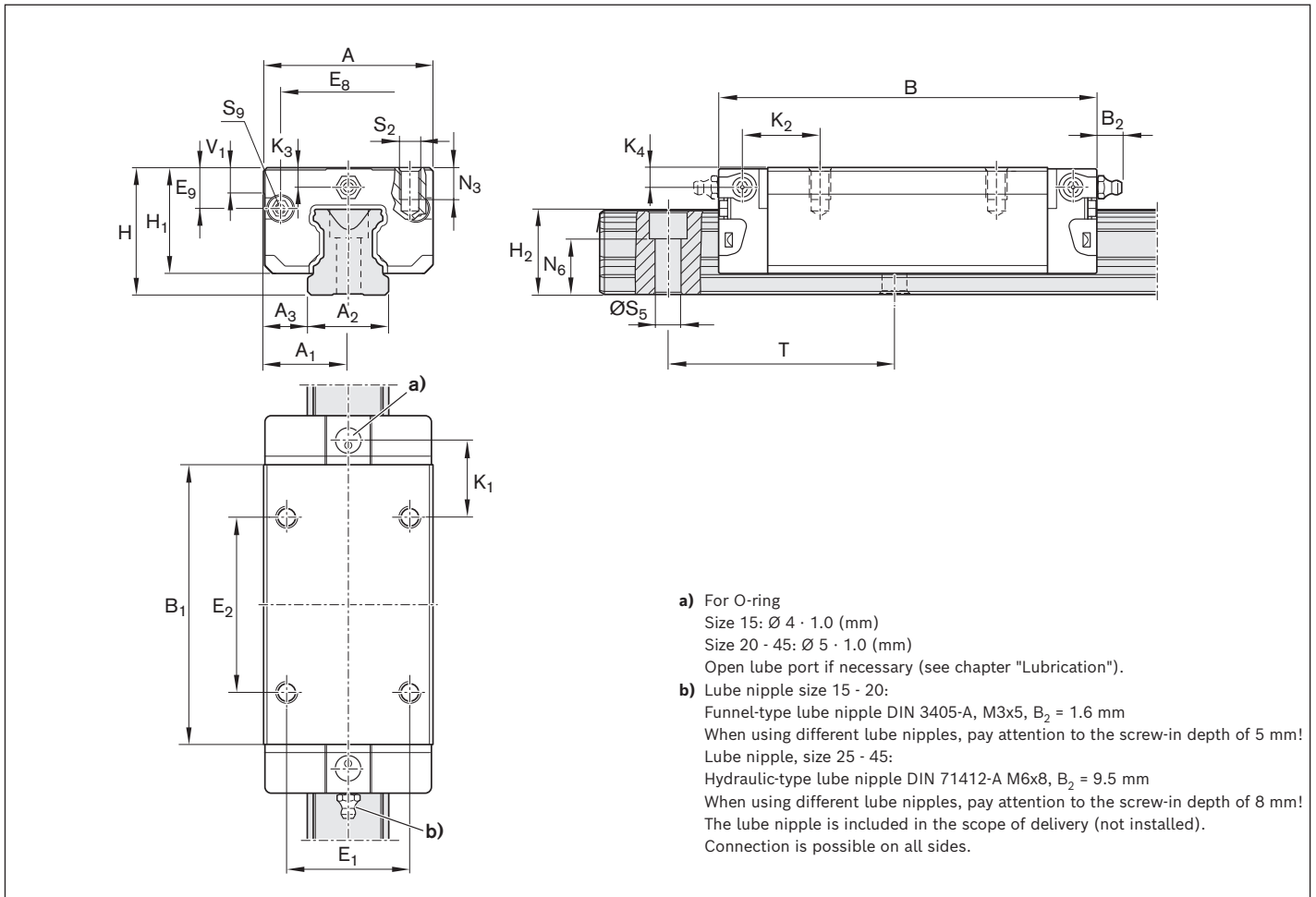

Size	Dimensions (mm)																	
	A	A ₁	A ₂	A ₃	B ^{+0.5}	B ₁	E ₁	E ₂	E ₈	E ₉	H	H ₁	H ₂ ¹⁾	H ₂ ²⁾	K ₁	K ₂	K ₃	K ₄
15	34	17	15	9.5	72.6	53.6	26	26	24.55	6.70	24	19.90	16.30	16.20	17.20	18.80	3.20	3.20
20	44	22	20	12.0	91.0	65.6	32	50	32.50	7.30	30	25.35	20.75	20.55	14.80	14.80	3.35	3.35
25	48	24	23	12.5	107.9	79.5	35	50	38.30	11.50	36	29.90	24.45	24.25	20.80	21.95	5.50	5.50
30	60	30	28	16.0	119.7	89.4	40	60	48.40	14.60	42	35.35	28.55	28.35	21.00	22.70	6.05	6.05
35	70	35	34	18.0	139.0	105.5	50	72	58.00	17.35	48	40.40	32.15	31.85	23.75	25.25	6.90	6.90
45	86	43	45	20.5	174.1	133.5	60	80	69.80	20.90	60	50.30	40.15	39.85	35.50	37.50	8.20	8.20

Size	Dimensions (mm)									Mass (kg)	Load capacities ³⁾ (N)		Load moments ³⁾ (Nm)			
	N ₃	N ₆ ^{+0.5}	S ₂	S ₅	S ₉	T	V ₁	m	C		C ₀	M _t	M _{t0}	M _L	M _{L0}	
15	6.0	10.3	M4	4.5	M2,5x3,5	60	5.0	0.20	12800	18400	120	180	120	180		
20	7.5	13.2	M5	6.0	M3x5	60	6.0	0.45	29600	41800	380	540	340	490		
25	9.0	15.2	M6	7.0	M3x5	60	7.5	0.65	37300	52500	530	750	530	740		
30	12.0	17.0	M8	9.0	M3x5	80	7.0	1.10	46000	66900	800	1160	740	1080		
35	13.0	20.5	M8	9.0	M3x5	80	8.0	1.70	66700	116000	1440	2500	1290	2240		
45	18.0	23.5	M10	14.0	M4x7	105	10.0	3.20	111000	190000	3010	5120	2730	4660		

- 1) Dimension H₂ with cover strip
- 2) Dimension H₂ without cover strip
- 3) Load capacities and load moments for ball runner block **without** ball chain. Load capacities and load moments for ball runner block **with** ball chain 12

Determination of the dynamic load capacities and load moments is based on a stroke travel of 100,000 m according to DIN ISO 14728-1. Often only 50,000 m are actually stipulated. For comparison: Multiply the values **C**, **M_t** and **M_L** by 1.26 according to the table.

SKS – Slimline, short, standard height R1666 ... 2.

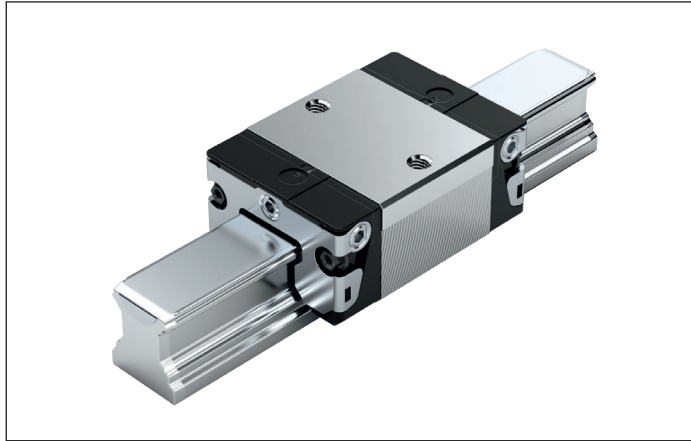

Dynamic characteristics

Speed: $v_{\max} = 5 \text{ m/s}$
 Acceleration: $a_{\max} = 500 \text{ m/s}^2$
 (If $F_{\text{comb}} > 2.8 \cdot F_{\text{pr}}$: $a_{\max} = 50 \text{ m/s}^2$)

Note on lubrication

► Pre-lubricated

Note

Can be used on all SNS/SNO ball guide rails.

Options and material numbers

Size	Ball runner block with size	Preload class		Accuracy class		Seal on ball runner block					
		C0	C1	N	H	without ball chain			with ball chain		
						SS	LS	DS	SS	LS	DS
15	R1666 1	9		4	3	20	21	–	22	23	–
			1	4	3	20	21	2Z	22	23	2Y
20	R1666 8	9		4	3	20	21	–	22	23	–
			1	4	3	20	21	2Z	22	23	2Y
25	R1666 2	9		4	3	20	21	–	22	23	–
			1	4	3	20	21	2Z	22	23	2Y
30	R1666 7	9		4	3	20	21	–	22	23	–
			1	4	3	20	21	2Z	22	23	2Y
35	R1666 3	9		4	3	20	21	–	22	23	–
			1	4	3	20	21	2Z	22	23	2Y
E.g.:	R1666 7		1		3	20					

Ordering example

Options:

- Ball runner block SKS
- Size 30
- Preload class C1
- Accuracy class H
- With standard seal, without ball chain

Material number:

R1666 713 20

Preload classes

C0 = Without preload (clearance)
 C1 = Moderate preload

Seals

SS = Standard seal
 LS = Low-friction seal
 DS = Double-lip seal

Key

gray numbers
 = no preferred variant / combination
 (partially longer delivery times)

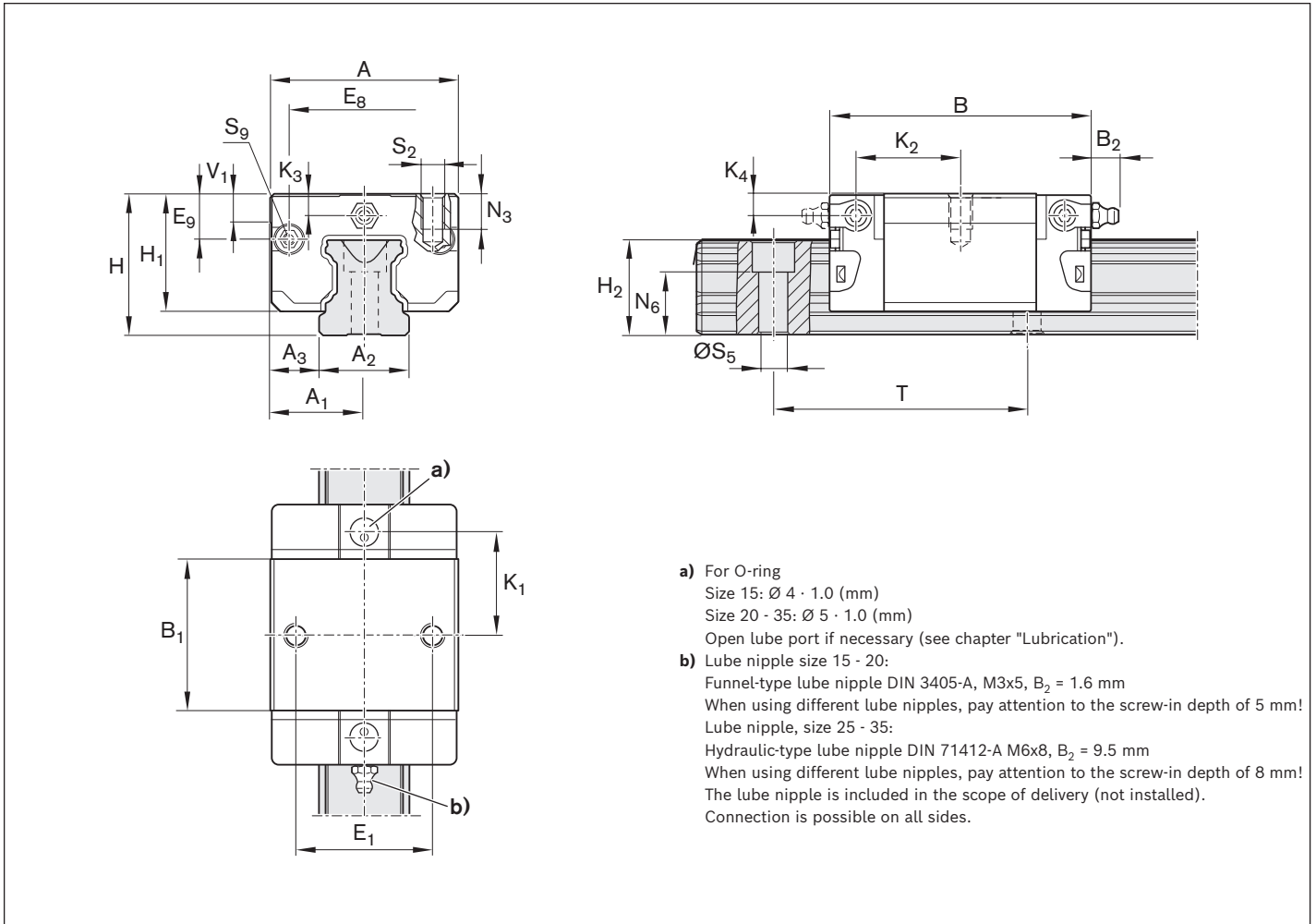

Size	Dimensions (mm)																
	A	A ₁	A ₂	A ₃	B ^{+0.5}	B ₁	E ₁	E ₈	E ₉	H	H ₁	H ₂ ¹⁾	H ₂ ²⁾	K ₁	K ₂	K ₃	K ₄
15	34	17	15	9.5	44.7	25.7	26	24.55	6.70	24	19.90	16.30	16.20	16.25	17.85	3.20	3.20
20	44	22	20	12.0	57.3	31.9	32	32.50	7.30	30	25.35	20.75	20.55	22.95	22.95	3.35	3.35
25	48	24	23	12.5	67.0	38.6	35	38.30	11.50	36	29.90	24.45	24.25	25.35	26.50	5.50	5.50
30	60	30	28	16.0	75.3	45.0	40	48.40	14.60	42	35.35	28.55	28.35	28.80	30.50	6.05	6.05
35	70	35	34	18.0	84.9	51.4	50	58.00	17.35	48	40.40	32.15	31.85	32.70	34.20	6.90	6.90

Size	Dimensions (mm)							Mass (kg)	Load capacities ³⁾ (N)		Load moments ³⁾ (Nm)			
	N ₃	N ₆ ^{±0.5}	S ₂	S ₅	S ₉	T	V ₁		C	C ₀	M _t	M _{t0}	M _L	M _{L0}
15	6.0	10.3	M4	4.5	M2,5x3,5	60	5.0	0.10	6720	7340	65	71	29	32
20	7.5	13.2	M5	6.0	M3x5	60	6.0	0.25	15400	16500	200	210	83	89
25	9.0	15.2	M6	7.0	M3x5	60	7.5	0.35	19800	21200	280	300	130	140
30	12.0	17.0	M8	9.0	M3x5	80	7.0	0.60	25600	28900	440	500	200	230
35	13.0	20.5	M8	9.0	M3x5	80	8.0	0.90	36600	49300	790	1060	340	460

- 1) Dimension H₂ with cover strip
- 2) Dimension H₂ without cover strip
- 3) Load capacities and load moments for ball runner block **without** ball chain. Load capacities and load moments for ball runner block **with** ball chain ☞ 12

Determination of the dynamic load capacities and load moments is based on a stroke travel of 100,000 m according to DIN ISO 14728-1. Often only 50,000 m are actually stipulated. For comparison: Multiply the values **C**, **M_t** and **M_L** by 1.26 according to the table.

SNH – Slimline, normal, high R1621 ... 2.

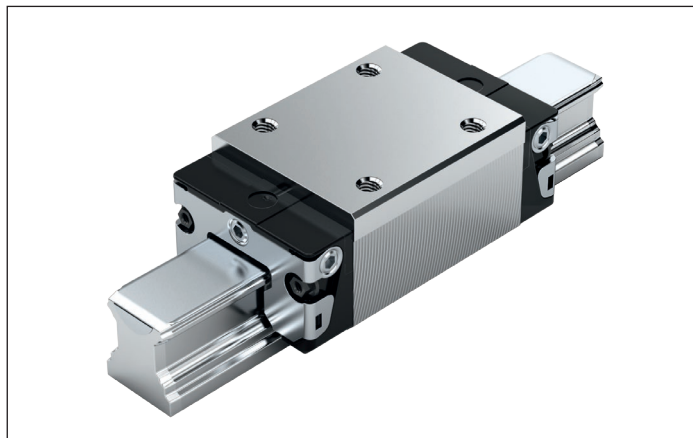

Dynamic characteristics

Speed: $v_{max} = 5 \text{ m/s}$
 Acceleration: $a_{max} = 500 \text{ m/s}^2$
 (If $F_{comb} > 2.8 \cdot F_{pr}$: $a_{max} = 50 \text{ m/s}^2$)

Note on lubrication

► Pre-lubricated

Note

Can be used on all SNS/SNO ball guide rails. Ball runner blocks of size 55 can be found in chapter "Heavy-duty ball runner block BSHP made of steel" after this chapter.

Options and material numbers

Size	Ball runner block with size	Preload class				Accuracy class				Seal on ball runner block					
		C0	C1	C2	C3	N	H	P	XP	without ball chain			with ball chain		
										SS	LS ¹⁾	DS	SS	LS ¹⁾	DS
15	R1621 1	9				4	3	-	-	20	21	-	22	23	-
			1			4	3	2	8	20	21	2Z	22	23	2Y
				2		-	3	2	8	20	21	2Z	22	23	2Y
					3	-	-	-	8	20	21	2Z	22	23	2Y
25	R1621 2	9				4	3	-	-	20	21	-	22	23	-
			1			4	3	2	8	20	21	2Z	22	23	2Y
				2		-	3	2	8	20	21	2Z	22	23	2Y
					3	-	-	-	8	20	21	2Z	22	23	2Y
30	R1621 7	9				4	3	-	-	20	21	-	22	23	-
			1			4	3	2	8	20	21	2Z	22	23	2Y
				2		-	3	2	8	20	21	2Z	22	23	2Y
					3	-	-	-	8	20	21	2Z	22	23	2Y
35	R1621 3	9				4	3	-	-	20	21	-	22	23	-
			1			4	3	2	8	20	21	2Z	22	23	2Y
				2		-	3	2	8	20	21	2Z	22	23	2Y
					3	-	-	-	8	20	21	2Z	22	23	2Y
45	R1621 4	9				4	3	-	-	20	-	-	22	-	-
			1			4	3	2	8	20	-	2Z	22	-	2Y
				2		-	3	2	8	20	-	2Z	22	-	2Y
					3	-	-	-	8	20	-	2Z	22	-	2Y
E.g.:	R1621 7		1				3			20					

1) Only for accuracy classes N and H and for XP in preload class C1.

Ordering example

Options:

- Ball runner block SNH
- Size 30
- Preload class C1
- Accuracy class H
- With standard seal, without ball chain

Material number:

R1621 713 20

Preload classes

C0 = Without preload (clearance)
 C1 = Moderate preload
 C2 = Average preload
 C3 = High preload

Seals

SS = Standard seal
 LS = Low-friction seal
 DS = Double-lip seal

Key

gray numbers
 = no preferred variant / combination
 (partially longer delivery times)

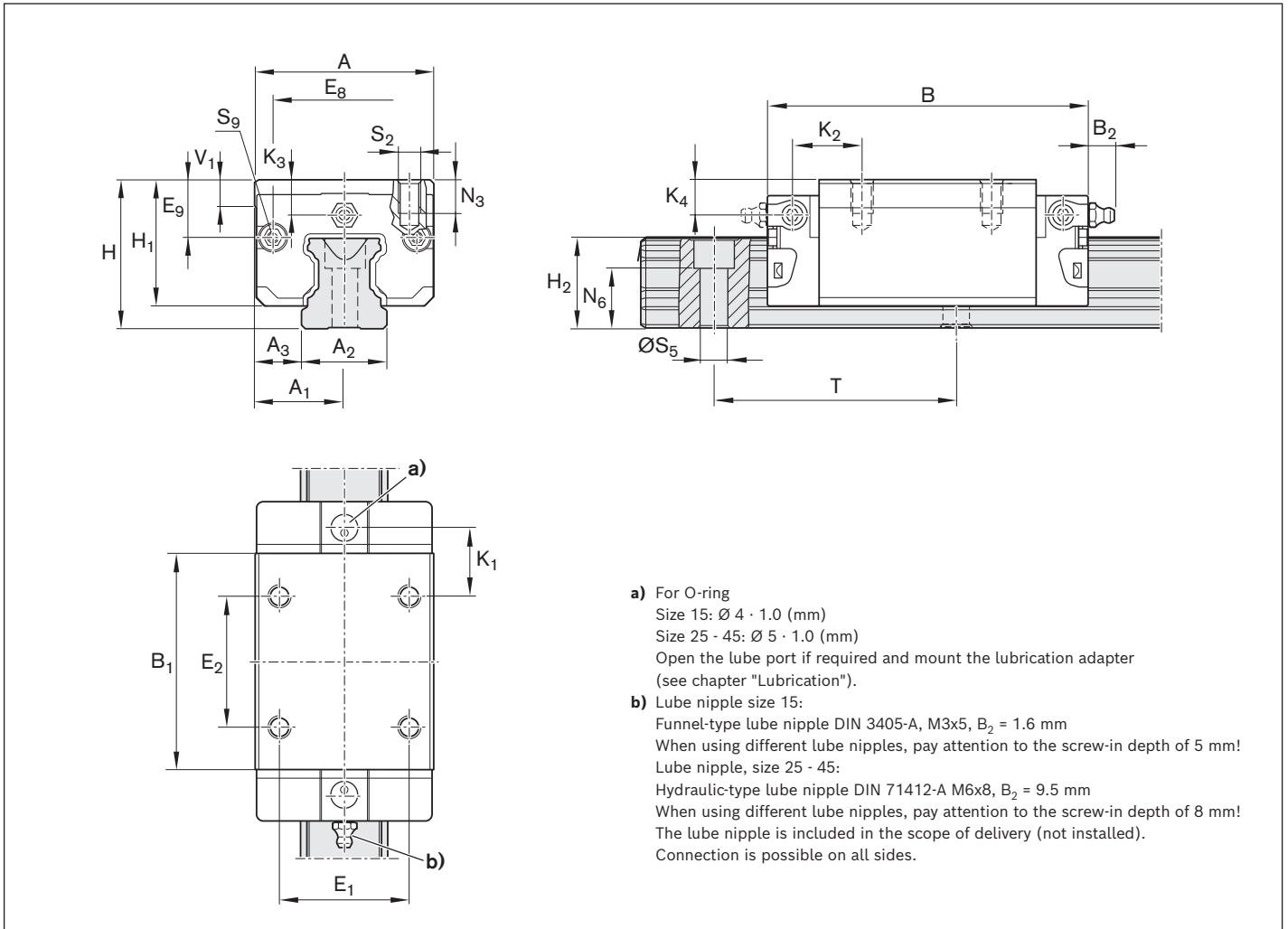

Size	Dimensions (mm)																		
	A	A ₁	A ₂	A ₃	B ^{+0.5}	B ₁	E ₁	E ₂	E ₈	E ₉	H	H ₁	H ₂ ¹⁾	H ₂ ²⁾	K ₁	K ₂	K ₃	K ₄	
15	34	17	15	9.5	58.2	39.2	26	26	24.55	10.70	28	23.90	16.30	16.20	10.00	11.60	7.20	7.20	
25	48	24	23	12.5	86.2	57.8	35	35	38.30	15.50	40	33.90	24.45	24.25	17.45	18.60	9.50	9.50	
30	60	30	28	16.0	97.7	67.4	40	40	48.40	17.60	45	38.35	28.55	28.35	20.00	21.70	9.05	9.05	
35	70	35	34	18.0	110.5	77.0	50	50	58.00	24.35	55	47.40	32.15	31.85	20.50	22.00	13.90	13.90	
45	86	43	45	20.5	137.6	97.0	60	60	69.80	30.90	70	60.30	40.15	39.85	27.30	29.30	18.20	18.20	

Size	Dimensions (mm)							Mass (kg)	Load capacities ³⁾ (N)		Load moments ³⁾ (Nm)			
	N ₃	N ₆ ^{±0.5}	S ₂	S ₅	S ₉	T	V ₁		m	C	C ₀	M _t	M _{t0}	M _L
15	6.0	10.3	M4	4.5	M2,5x3,5	60	5.0	0.20	9860	12700	95	120	68	87
25	9.0	15.2	M6	7.0	M3x5	60	7.5	0.60	28600	35900	410	510	290	360
30	12.0	17.0	M8	9.0	M3x5	80	7.0	0.95	36500	48100	630	830	440	580
35	13.0	20.5	M8	9.0	M3x5	80	8.0	1.55	51800	80900	1110	1740	720	1130
45	18.0	23.5	M10	14.0	M4x7	105	10.0	3.00	86400	132000	2330	3560	1540	2350

- 1) Dimension H₂ with cover strip
- 2) Dimension H₂ without cover strip
- 3) Load capacities and load moments for ball runner block **without** ball chain. Load capacities and load moments for ball runner block **with** ball chain 12
 Determination of the dynamic load capacities and load moments is based on a stroke travel of 100,000 m according to DIN ISO 14728-1. Often only 50,000 m are actually stipulated. For comparison: Multiply the values **C**, **M_t** and **M_L** by 1.26 according to the table.

SLH – Slimline, long, high R1624 ... 2.

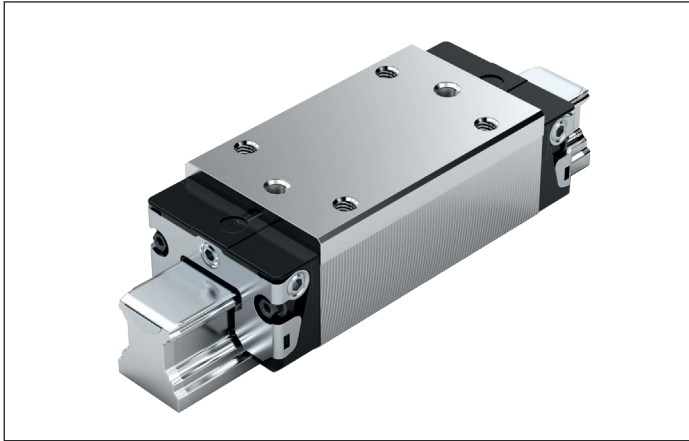

Dynamic characteristics

Speed: $v_{max} = 5 \text{ m/s}$
 Acceleration: $a_{max} = 500 \text{ m/s}^2$
 (If $F_{comb} > 2.8 \cdot F_{pr}$: $a_{max} = 50 \text{ m/s}^2$)

Note on lubrication

► Pre-lubricated

Note

Can be used on all SNS/SNO ball guide rails. Ball runner blocks of size 55 can be found in chapter "Heavy-duty ball runner block BSHP made of steel" after this chapter.

Options and material numbers

Size	Ball runner block with size	Preload class				Accuracy class				Seal on ball runner block						
		C0	C1	C2	C3	N	H	P	XP	without ball chain			with ball chain			
										SS	LS ¹⁾	DS	SS	LS ¹⁾	DS	
25	R1624 2	9				4	3	-	-	20	21	-	22	23	-	
			1			4	3	2	8	20	21	2Z	22	23	2Y	
				2		-	3	2	8	20	21	2Z	22	23	2Y	
					3	-	-	-	8	20	21	2Z	22	23	2Y	
30	R1624 7	9				4	3	-	-	20	21	-	22	23	-	
			1			4	3	2	8	20	21	2Z	22	23	2Y	
				2		-	3	2	8	20	21	2Z	22	23	2Y	
					3	-	-	-	8	20	21	2Z	22	23	2Y	
35	R1624 3	9				4	3	-	-	20	21	-	22	23	-	
			1			4	3	2	8	20	21	2Z	22	23	2Y	
				2		-	3	2	8	20	21	2Z	22	23	2Y	
					3	-	-	-	8	20	21	2Z	22	23	2Y	
45	R1624 4	9				4	3	-	-	20	-	-	22	-	-	
			1			4	3	2	8	20	-	2Z	22	-	2Y	
				2		-	3	2	8	20	-	2Z	22	-	2Y	
					3	-	-	-	8	20	-	2Z	22	-	2Y	
E.g.:	R16247		1			3				20						

1) Only for accuracy classes N and H and for XP in preload class C1.

Ordering example

Options:

- Ball runner block SLH
- Size 30
- Preload class C1
- Accuracy class H
- With standard seal, without ball chain

Material number:

R1624 713 20

Preload classes

C0 = Without preload (clearance)
 C1 = Moderate preload
 C2 = Average preload
 C3 = High preload

Seals

SS = Standard seal
 LS = Low-friction seal
 DS = Double-lip seal

Key

gray numbers
 = no preferred variant / combination
 (partially longer delivery times)

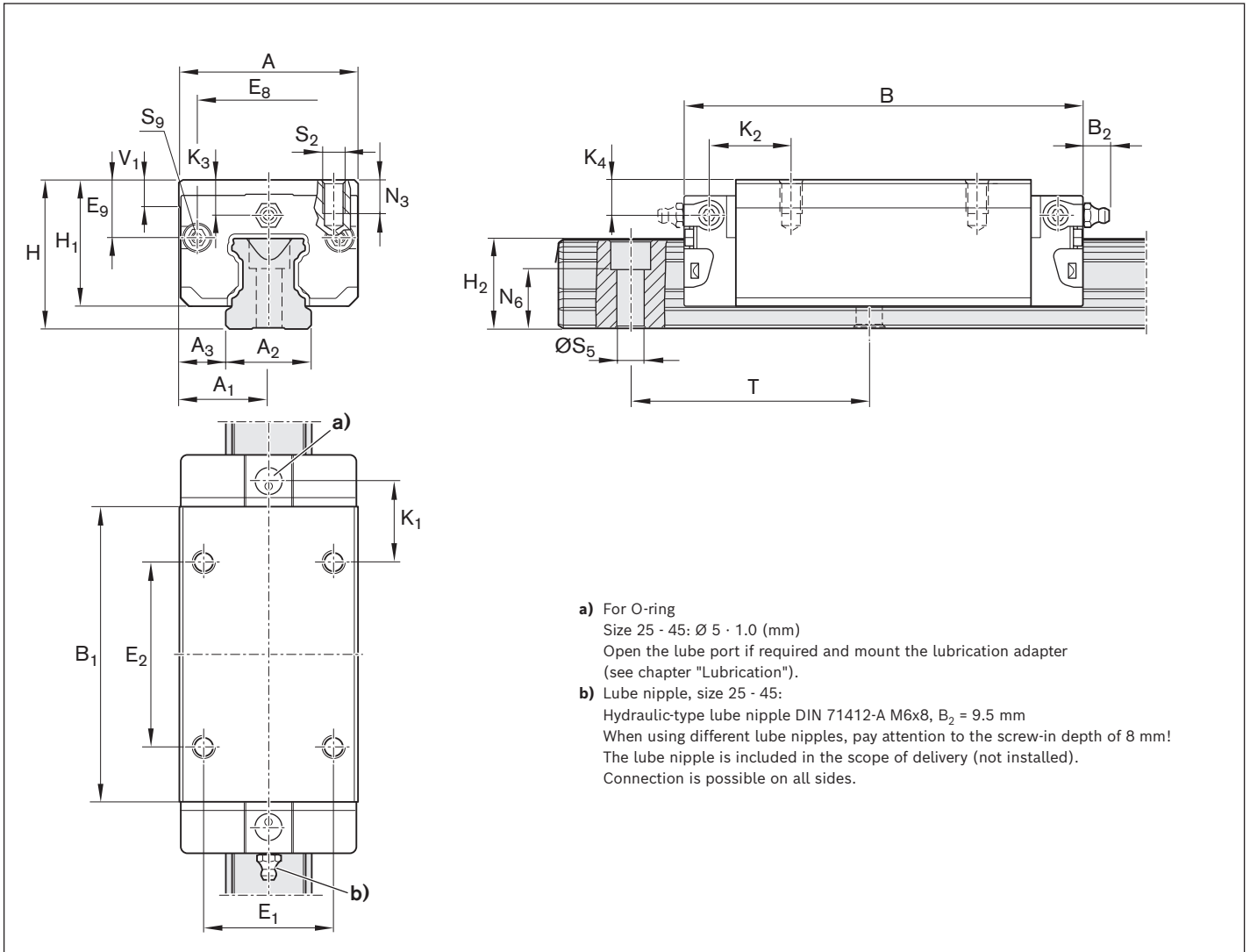

- a) For O-ring
Size 25 - 45: $\text{Ø } 5 \cdot 1.0$ (mm)
Open the lube port if required and mount the lubrication adapter (see chapter "Lubrication").
- b) Lube nipple, size 25 - 45:
Hydraulic-type lube nipple DIN 71412-A M6x8, $B_2 = 9.5$ mm
When using different lube nipples, pay attention to the screw-in depth of 8 mm!
The lube nipple is included in the scope of delivery (not installed).
Connection is possible on all sides.

Size	Dimensions (mm)																		
	A	A ₁	A ₂	A ₃	B ^{+0.5}	B ₁	E ₁	E ₂	E ₈	E ₉	H	H ₁	H ₂ ¹⁾	H ₂ ²⁾	K ₁	K ₂	K ₃	K ₄	
25	48	24	23	12.5	107.9	79.5	35	50	38.30	15.50	40	33.90	24.45	24.25	20.80	21.95	9.50	9.50	
30	60	30	28	16.0	119.7	89.4	40	60	48.40	17.60	45	38.35	28.55	28.35	21.00	22.70	9.05	9.05	
35	70	35	34	18.0	139.0	105.5	50	72	58.00	24.35	55	47.40	32.15	31.85	23.75	25.25	13.90	13.90	
45	86	43	45	20.5	174.1	133.5	60	80	69.80	30.90	70	60.30	40.15	39.85	35.50	37.50	18.20	18.20	

Size	Dimensions (mm)								Mass (kg)	Load capacities ³⁾ (N)		Load moments ³⁾ (Nm)			
	N ₃	N ₆ ^{+0.5}	S ₂	S ₅	S ₉	T	V ₁	m		C	C ₀	M _t	M _{t0}	M _L	M _{L0}
25	9.0	15.2	M6	7.0	M3x5	60	7.5	0.80	37300	52500	530	750	530	740	
30	12.0	17.0	M8	9.0	M3x5	80	7.0	1.20	46000	66900	800	1160	740	1080	
35	13.0	20.5	M8	9.0	M3x5	80	8.0	2.10	66700	116000	1440	2500	1290	2240	
45	18.0	23.5	M10	14.0	M4x7	105	10.0	4.10	111000	190000	3010	5120	2730	4660	

- 1) Dimension H₂ with cover strip
- 2) Dimension H₂ without cover strip
- 3) Load capacities and load moments for ball runner block **without** ball chain. Load capacities and load moments for ball runner block **with** ball chain 12

Determination of the dynamic load capacities and load moments is based on a stroke travel of 100,000 m according to DIN ISO 14728-1. Often only 50,000 m are actually stipulated. For comparison: Multiply the values **C**, **M_t** and **M_L** by 1.26 according to the table.

FNN – Flange, normal, low R1693 ... 1.

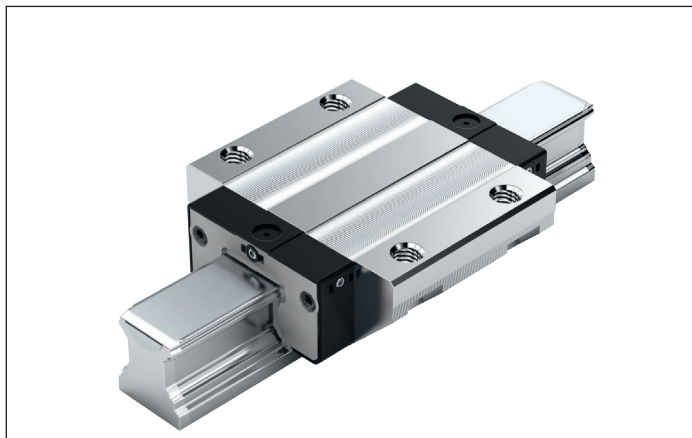

Dynamic characteristics

Speed: $v_{max} = 3 \text{ m/s}$
 Acceleration: $a_{max} = 250 \text{ m/s}^2$
 (If $F_{comb} > 2.8 \cdot F_{pr}$: $a_{max} = 50 \text{ m/s}^2$)

Note on lubrication

▶ No initial lubrication

Note

Can be used on all SNS/SNO ball guide rails.

Options and material numbers

Size	Ball runner block with size	Preload class		Accuracy class			Seal on ball runner block without ball chain	
		C0	C1	N	H	SS	LS	
20	R1693 8	9	1	4	3	10	11	
25 ¹⁾	R1693 2	9	1	4	3	10	11	
E.g.:	R1693 8		1		3	10		

1) Ball runner block BSHP

Ordering example

Options:

- ▶ Ball runner block FNN
- ▶ Size 20
- ▶ Preload class C1
- ▶ Accuracy class H
- ▶ With standard seal, without ball chain

Material number:

R1693 813 10

Preload classes

C0 = Without preload (clearance)
 C1 = Moderate preload

Seals

SS = Standard seal
 LS = Low-friction seal

Key

gray numbers
 = no preferred variant / combination
 (partially longer delivery times)

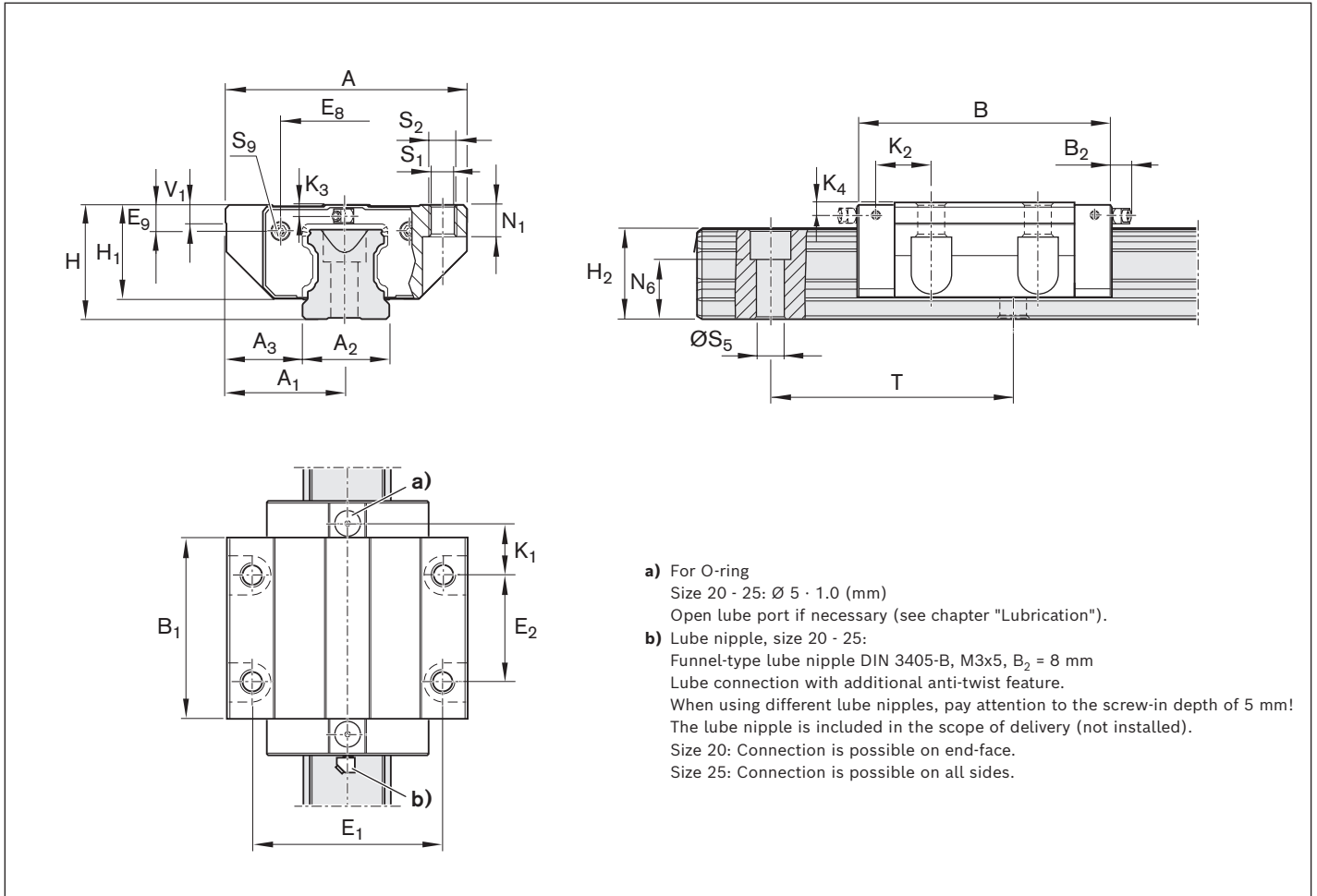

- a) For O-ring
Size 20 - 25: $\varnothing 5 \cdot 1.0$ (mm)
Open lube port if necessary (see chapter "Lubrication").
- b) Lube nipple, size 20 - 25:
Funnel-type lube nipple DIN 3405-B, M3x5, $B_2 = 8$ mm
Lube connection with additional anti-twist feature.
When using different lube nipples, pay attention to the screw-in depth of 5 mm!
The lube nipple is included in the scope of delivery (not installed).
Size 20: Connection is possible on end-face.
Size 25: Connection is possible on all sides.

Size	Dimensions (mm)																	
	A	A ₁	A ₂	A ₃	B ^{+0.5}	B ₁	E ₁	E ₂	E ₈	E ₉	H	H ₁	H ₂ ¹⁾	H ₂ ²⁾	K ₁	K ₂	K ₃	K ₄
20	59	29.5	20	19.5	72.5	49.6	49	32	30.5	5.6	28	23.0	20.75	20.55	13.0	-	3.6	-
25	73	36.5	23	25.0	81.0	57.8	60	35	38.3	8.5	33	26.5	24.45	24.25	16.6	17.0	4.1	4.1

Size	Dimensions (mm)									Mass (kg)	Load capacities ³⁾ (N)		Load moments ³⁾ (Nm)			
	N ₁	N ₆ ^{±0.5}	S ₁	S ₂	S ₅	S ₉	T	V ₁	m		C	C ₀	M _t	M _{t0}	M _L	M _{L0}
20	7.7	13.2	5.3	M6	6.0	M3x5	60	6.0	0.40	14500	24400	190	310	100	165	
25	9.3	15.2	6.7	M8	7.0	M3x5	60	7.5	0.60	28600	35900	410	510	290	360	

- 1) Dimension H₂ with cover strip
- 2) Dimension H₂ without cover strip
- 3) Load capacities and load moments for ball runner block **without** ball chain.
Determination of the dynamic load capacities and load moments is based on a stroke travel of 100,000 m according to DIN ISO 14728-1. Often only 50,000 m are actually stipulated. For comparison: Multiply the values **C**, **M_t** and **M_L** by 1.26 according to the table.

FKN – Flange, short, low R1663 ... 1.

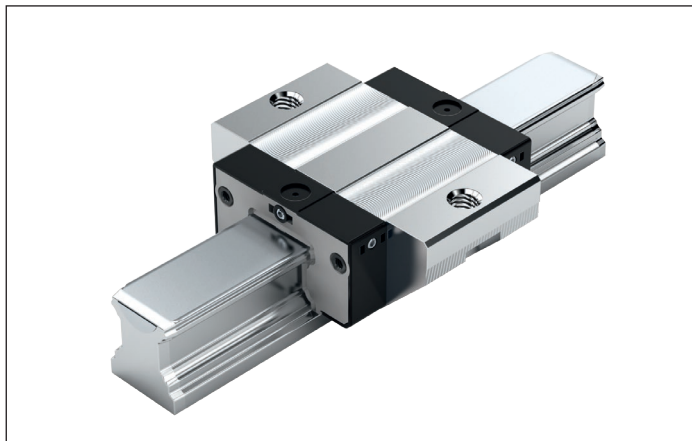

Dynamic characteristics

Speed: $v_{max} = 3 \text{ m/s}$
 Acceleration: $a_{max} = 250 \text{ m/s}^2$
 (If $F_{comb} > 2.8 \cdot F_{pr}$: $a_{max} = 50 \text{ m/s}^2$)

Note on lubrication

► No initial lubrication

Note

Can be used on all SNS/SNO ball guide rails.

Options and material numbers

Size	Ball runner block with size	Preload class		Accuracy class		Seal on ball runner block without ball chain	
		C0	C1	N	H	SS	LS
20	R1663 8	9	1	4	3	10	11
25 ¹⁾	R1663 2	9	1	4	3	10	11
E.g.:	R1663 8		1		3	10	

1) Ball runner block BSHP

Ordering example

Options:

- Ball runner block FKN
- Size 20
- Preload class C1
- Accuracy class H
- With standard seal, without ball chain

Material number:

R1663 813 10

Preload classes

C0 = Without preload (clearance)
 C1 = Moderate preload

Seals

SS = Standard seal
 LS = Low-friction seal

Key

gray numbers
 = no preferred variant / combination
 (partially longer delivery times)

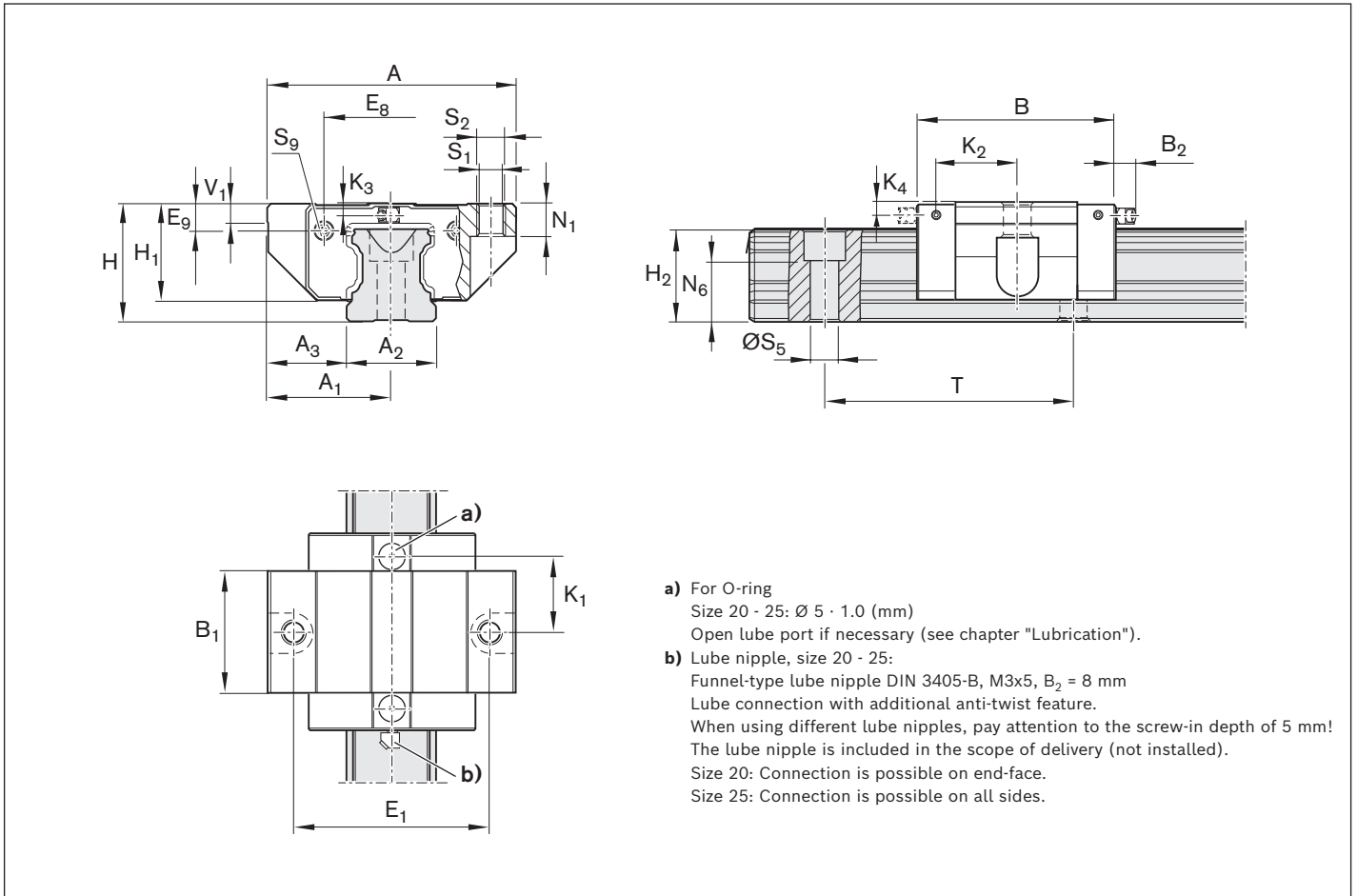

- a) For O-ring
Size 20 - 25: Ø 5 · 1.0 (mm)
Open lube port if necessary (see chapter "Lubrication").
- b) Lube nipple, size 20 - 25:
Funnel-type lube nipple DIN 3405-B, M3x5, B₂ = 8 mm
Lube connection with additional anti-twist feature.
When using different lube nipples, pay attention to the screw-in depth of 5 mm!
The lube nipple is included in the scope of delivery (not installed).
Size 20: Connection is possible on end-face.
Size 25: Connection is possible on all sides.

Size	Dimensions (mm)																	
	A	A ₁	A ₂	A ₃	B ^{+0.5}	B ₁	E ₁	E ₈	E ₉	H	H ₁	H ₂ ¹⁾	H ₂ ²⁾	K ₁	K ₂	K ₃	K ₄	
20	59	29.5	20	19.5	55	31.9	49	30.5	5.6	28	23.0	20.75	20.55	20.1	-	3.6	-	
25	73	36.5	23	25.0	62	38.6	60	38.3	8.5	33	26.5	24.45	24.25	24.5	25.0	4.1	4.1	

Size	Dimensions (mm)									Mass (kg)	Load capacities ³⁾ (N)		Load moments ³⁾ (Nm)			
	N ₁	N ₆ ^{±0.5}	S ₁	S ₂	S ₅	S ₉	T	V ₁	m		C	C ₀	M _t	M _{t0}	M _L	M _{L0}
20	7.7	13.2	5.3	M6	6.0	M3x5	60	6.0	0.25	9600	13600	120	170	40	58	
25	9.3	15.2	6.7	M8	7.0	M3x5	60	7.5	0.45	19800	21200	280	300	130	140	

- 1) Dimension H₂ with cover strip
- 2) Dimension H₂ without cover strip
- 3) Load capacities and load moments for ball runner block **without** ball chain.
Determination of the dynamic load capacities and load moments is based on a stroke travel of 100,000 m according to DIN ISO 14728-1. Often only 50,000 m are actually stipulated. For comparison: Multiply the values **C**, **M_t** and **M_L** by 1.26 according to the table.

SNN – Slimline, normal, low R1694 ... 1.

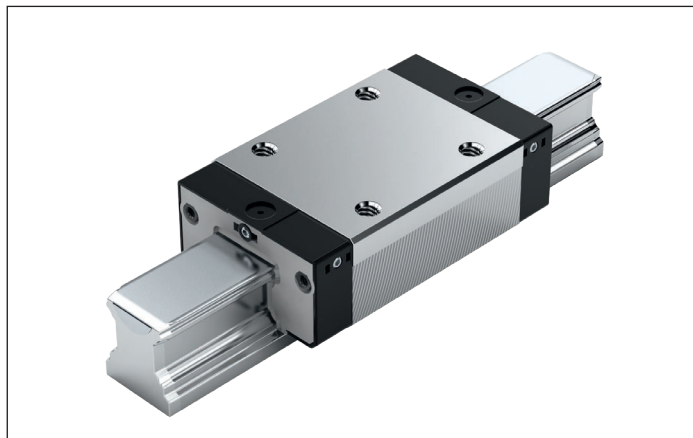

Dynamic characteristics

Speed: $v_{max} = 3 \text{ m/s}$
 Acceleration: $a_{max} = 250 \text{ m/s}^2$
 (If $F_{comb} > 2.8 \cdot F_{pr}$: $a_{max} = 50 \text{ m/s}^2$)

Note on lubrication

▶ No initial lubrication

Note

Can be used on all SNS/SNO ball guide rails.

Options and material numbers

Size	Ball runner block with size	Preload class		Accuracy class			Seal on ball runner block without ball chain	
		C0	C1	N	H	SS	LS	
20	R1694 8	9	1	4	3	10	11	
25 ¹⁾	R1694 2	9	1	4	3	10	11	
E.g.:	R1694 8		1		3	10		

1) Ball runner block BSHP

Ordering example

Options:

- ▶ Ball runner block SNN
- ▶ Size 20
- ▶ Preload class C1
- ▶ Accuracy class H
- ▶ With standard seal, without ball chain

Material number:

R1694 813 10

Preload classes

C0 = Without preload (clearance)
 C1 = Moderate preload

Seals

SS = Standard seal
 LS = Low-friction seal

Key

gray numbers
 = no preferred variant / combination
 (partially longer delivery times)

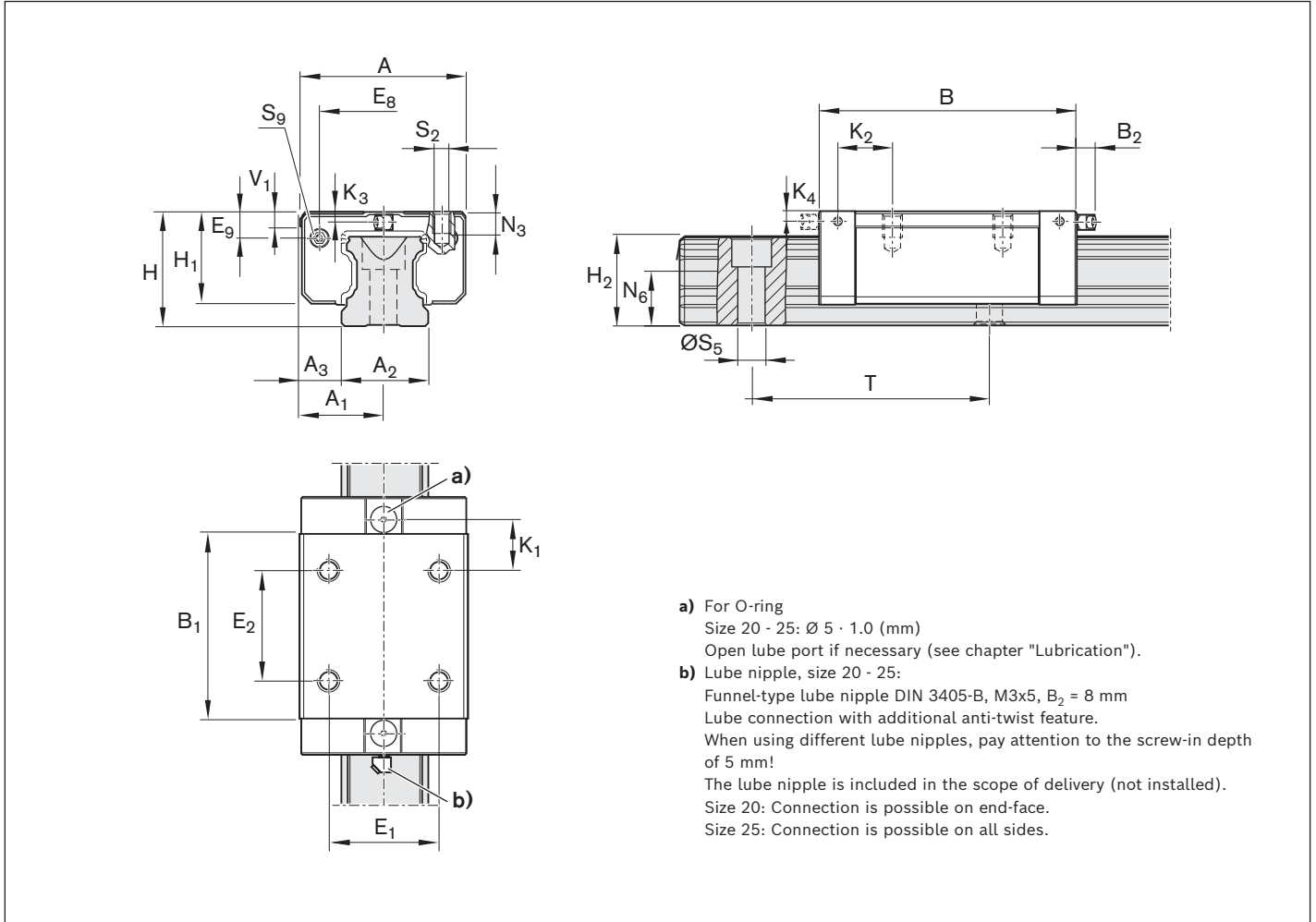

Size	Dimensions (mm)																	
	A	A ₁	A ₂	A ₃	B ^{+0.5}	B ₁	E ₁	E ₂	E ₈	E ₉	H	H ₁	H ₂ ¹⁾	H ₂ ²⁾	K ₁	K ₂	K ₃	K ₄
20	42	21	20	11.0	72.5	49.6	32	32	30.5	5.6	28	23.0	20.75	20.55	13.0	-	3.6	-
25	48	24	23	12.5	81.0	57.8	35	35	38.3	8.5	33	26.5	24.45	24.25	16.6	17.0	4.1	4.1

Size	Dimensions (mm)								Mass (kg)	Load capacities ³⁾ (N)		Load moments ³⁾ (Nm)			
	N ₃	N ₆ ^{±0.5}	S ₂	S ₅	S ₉	T	V ₁	m		C	C ₀	M _t	M _{t0}	M _L	M _{L0}
20	6.3	13.2	M5	6.0	M3x5	60	6.0	0.30	14500	24400	190	310	100	165	
25	7.0	15.2	M6	7.0	M3x5	60	7.5	0.45	28600	35900	410	510	290	360	

- 1) Dimension H₂ with cover strip
- 2) Dimension H₂ without cover strip
- 3) Load capacities and load moments for ball runner block **without** ball chain.
Determination of the dynamic load capacities and load moments is based on a stroke travel of 100,000 m according to DIN ISO 14728-1. Often only 50,000 m are actually stipulated. For comparison: Multiply the values **C**, **M_t** and **M_L** by 1.26 according to the table.

SKN – Slimline, short, low R1664 ... 1.

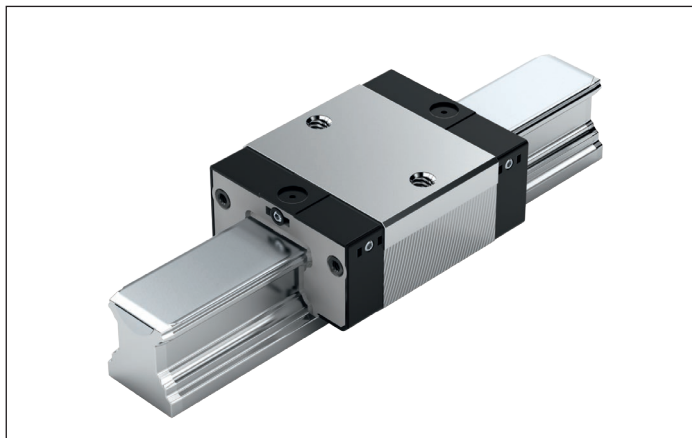

Dynamic characteristics

Speed: $v_{max} = 3 \text{ m/s}$
 Acceleration: $a_{max} = 250 \text{ m/s}^2$
 (If $F_{comb} > 2.8 \cdot F_{pr}$: $a_{max} = 50 \text{ m/s}^2$)

Note on lubrication

► No initial lubrication

Note

Can be used on all SNS/SNO ball guide rails.

Options and material numbers

Size	Ball runner block with size	Preload class		Accuracy class		Seal on ball runner block without ball chain	
		C0	C1	N	H	SS	LS
20	R1664 8	9	1	4	3	10	11
25 ¹⁾	R1664 2	9	1	4	3	10	11
E.g.:	R1664 8		1		3	10	

1) Ball runner block BSHP

Ordering example

Options:

- Ball runner block SKN
- Size 20
- Preload class C1
- Accuracy class H
- With standard seal, without ball chain

Material number:

R1664 813 10

Preload classes

C0 = Without preload (clearance)
 C1 = Moderate preload

Seals

SS = Standard seal
 LS = Low-friction seal

Key

gray numbers
 = no preferred variant / combination
 (partially longer delivery times)

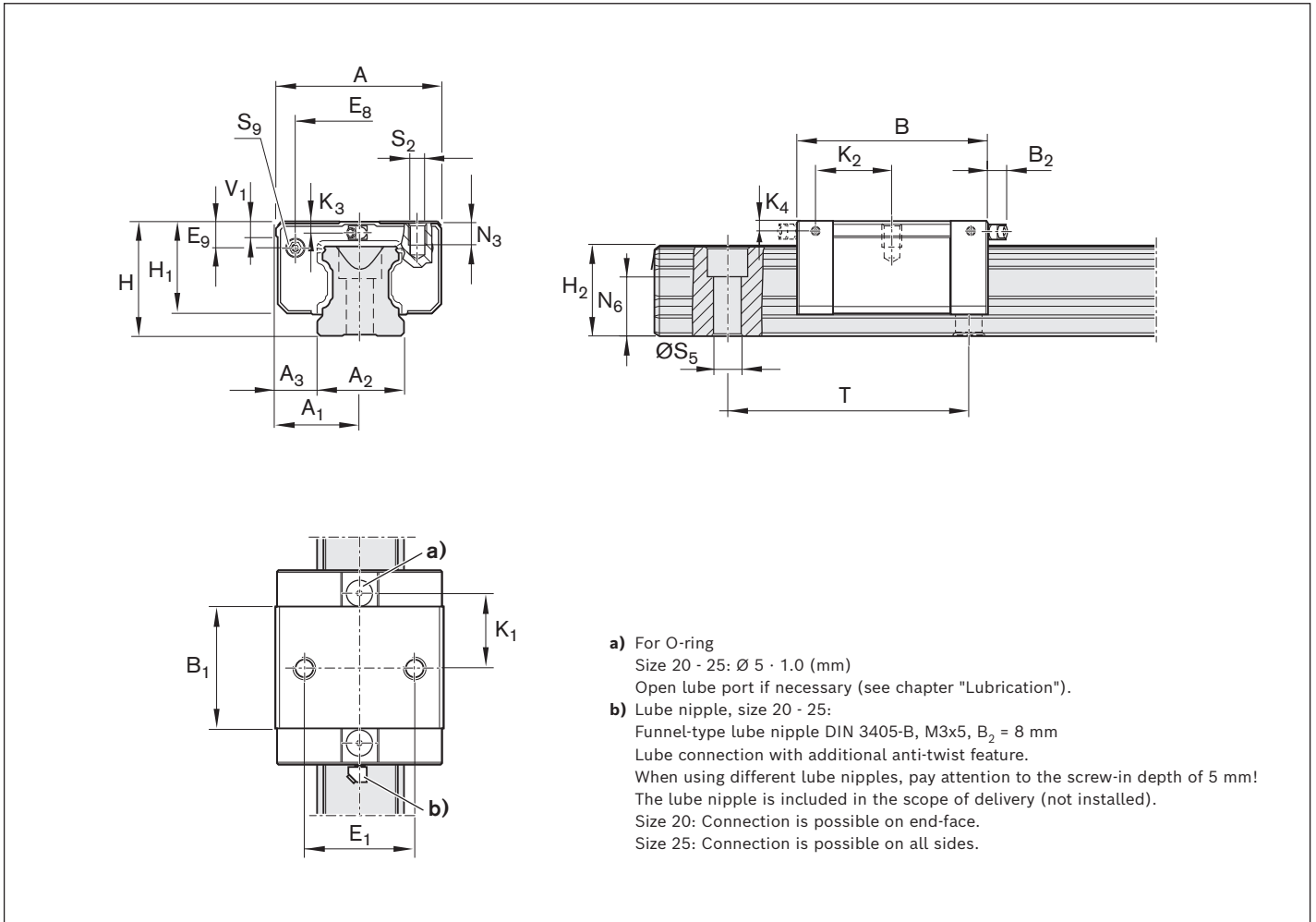

- a) For O-ring
Size 20 - 25: $\text{Ø } 5 \cdot 1.0$ (mm)
Open lube port if necessary (see chapter "Lubrication").
- b) Lube nipple, size 20 - 25:
Funnel-type lube nipple DIN 3405-B, M3x5, $B_2 = 8$ mm
Lube connection with additional anti-twist feature.
When using different lube nipples, pay attention to the screw-in depth of 5 mm!
The lube nipple is included in the scope of delivery (not installed).
Size 20: Connection is possible on end-face.
Size 25: Connection is possible on all sides.

Size	Dimensions (mm)																
	A	A ₁	A ₂	A ₃	B ^{+0.5}	B ₁	E ₁	E ₈	E ₉	H	H ₁	H ₂ ¹⁾	H ₂ ²⁾	K ₁	K ₂	K ₃	K ₄
20	42	21	20	11.0	55	31.9	32	30.5	5.6	28	23.0	20.75	20.55	20.1	-	3.6	-
25	48	24	23	12.5	62	38.6	35	38.3	8.5	33	26.5	24.45	24.25	24.5	25.0	4.1	4.1

Size	Dimensions (mm)							Mass (kg)	Load capacities ³⁾ (N)		Load moments ³⁾ (Nm)			
	N ₃	N ₆ ^{±0.5}	S ₂	S ₅	S ₉	T	V ₁		m	C	C ₀	M _t	M _{t0}	M _L
20	6.3	13.2	M5	6.0	M3x5	60	6.0	0.20	9600	13600	120	170	40	58
25	7.0	15.2	M6	7.0	M3x5	60	7.5	0.30	19800	21200	280	300	130	140

- 1) Dimension H₂ with cover strip
- 2) Dimension H₂ without cover strip
- 3) Load capacities and load moments for ball runner block **without** ball chain.
Determination of the dynamic load capacities and load moments is based on a stroke travel of 100,000 m according to DIN ISO 14728-1. Often only 50,000 m are actually stipulated. For comparison: Multiply the values **C**, **M_t** and **M_L** by 1.26 according to the table.

FNS – Flange, normal, standard height R1651 ... 1.

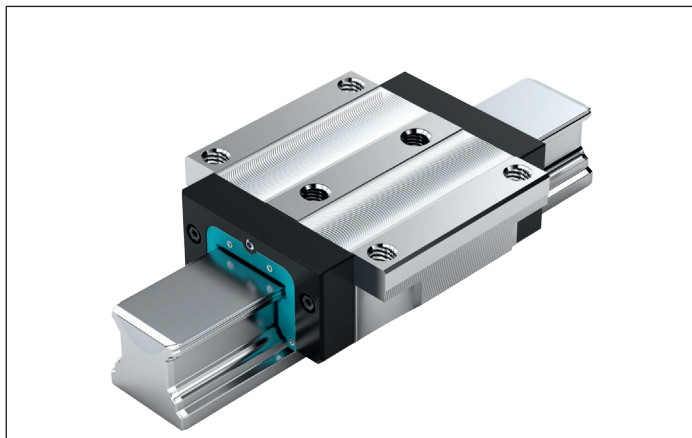

Dynamic characteristics

Speed: $v_{max} = 3 \text{ m/s}$
 Acceleration: $a_{max} = 250 \text{ m/s}^2$
 (If $F_{comb} > 2.8 \cdot F_{pr}$: $a_{max} = 50 \text{ m/s}^2$)

Note on lubrication

► No initial lubrication

Note

Can be used on all SNS ball guide rails.

Options and material numbers

Size	Ball runner block with size	Preload class				Accuracy class					Seal on ball runner block without ball chain	SS
		C0	C1	C2	C3	N	H	P	SP	UP		
55	R1651 5	9				4	3	-	-	-		10
			1			4	3	2	1	9		10
				2		-	3	2	1	9		10
					3	-	-	2	1	9		10
65	R1651 6	9				4	3	-	-	-		10
			1			4	3	2	1	9		10
				2		-	3	2	1	9		10
					3	-	-	2	1	9		10
E.g.:	R1651 5		1				3					10

Ordering example

Options:

- Ball runner block FNS
- Size 55
- Preload class C1
- Accuracy class H
- With standard seal, without ball chain

Material number:

R1651 513 10

Preload classes

- C0 = Without preload (clearance)
- C1 = Moderate preload
- C2 = Average preload
- C3 = High preload

Seals

SS = Standard seal

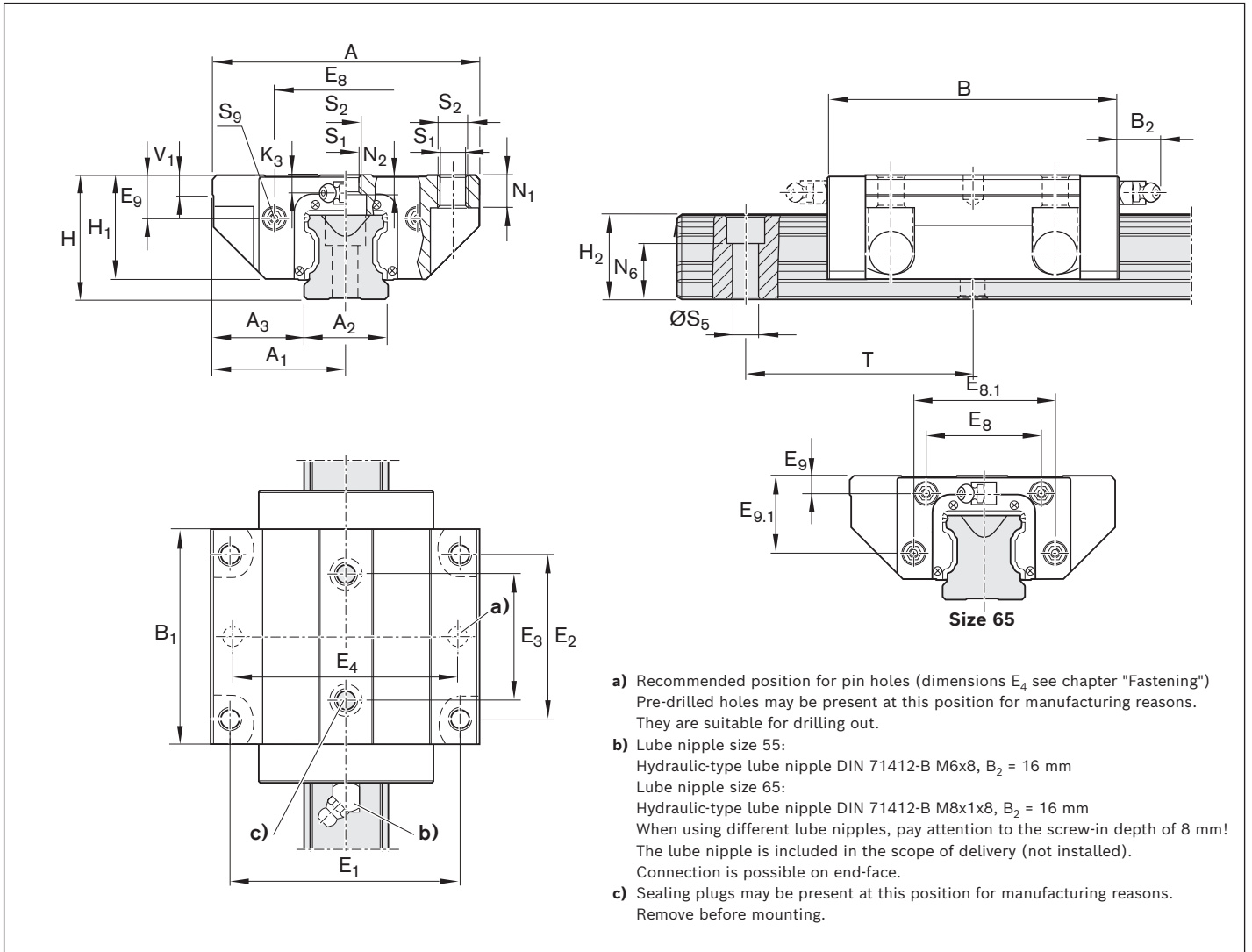

Size	Dimensions (mm)																
	A	A_1	A_2	A_3	$B^{+0.5}$	B_1	E_1	E_2	E_3	E_8	$E_{8.1}$	E_9	$E_{9.1}$	H	H_1	$H_2^{1)}$	$H_2^{2)}$
55	140	70	53	43.5	159	115.5	116	95	70	80	-	22.3	-	70	57	48.15	47.85
65	170	85	63	53.5	188	139.6	142	110	82	76	100	11.0	53.5	90	76	60.15	59.85

Size	Dimensions (mm)											Mass (kg)	Load capacities ³⁾ (N)		Load moments ³⁾ (Nm)			
	K_3	N_1	N_2	$N_6^{\pm 0.5}$	S_1	S_2	S_5	S_9	T	V_1	m		C	C_0	M_t	M_{t0}	M_L	M_{L0}
55	9	18	13.5	29.0	12.4	M14	16	M5x8	120	12	5.20	109000	174000	3480	5550	2320	3690	
65	16	23	14.0	38.5	14.6	M16	18	M4x7	150	15	10.25	172000	280000	6810	11100	4560	7400	

- 1) Dimension H_2 with cover strip.
- 2) Dimension H_2 without cover strip.
- 3) Load capacities and load moments for ball runner block **without** ball chain.
Determination of the dynamic load capacities and load moments is based on a stroke travel of 100,000 m according to DIN ISO 14728-1.
Often only 50,000 m are actually stipulated. For comparison: Multiply the values **C**, **M_t** and **M_L** by 1.26 according to the table.

FLS – Flange, long, standard height, R1653 ... 1.

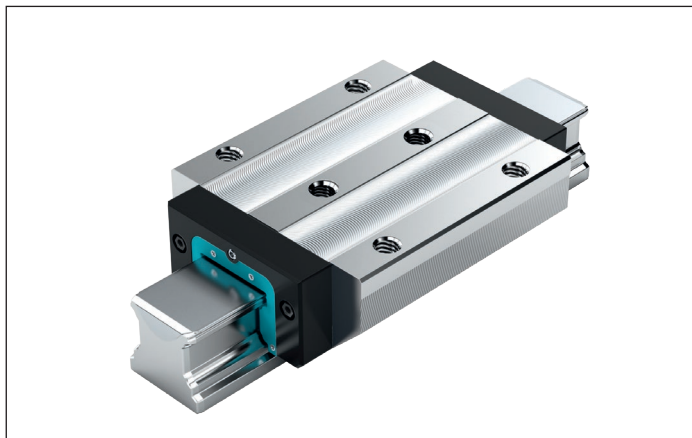

Dynamic characteristics

Speed: $v_{max} = 3 \text{ m/s}$
 Acceleration: $a_{max} = 250 \text{ m/s}^2$
 (If $F_{comb} > 2.8 \cdot F_{pr}$: $a_{max} = 50 \text{ m/s}^2$)

Note on lubrication

► No initial lubrication

Note

Can be used on all SNS ball guide rails.

Options and material numbers

Size	Ball runner block with size	Preload class				Accuracy class					Seal on ball runner block without ball chain	SS
		C0	C1	C2	C3	N	H	P	SP	UP		
55	R1653 5	9				4	3	-	-	-		10
			1			4	3	2	1	9		10
				2		-	3	2	1	9		10
					3	-	-	2	1	9		10
65	R1653 6	9				4	3	-	-	-		10
			1			4	3	2	1	9		10
				2		-	3	2	1	9		10
					3	-	-	2	1	9		10
E.g.:	R1653 5		1				3					10

Ordering example

Options:

- Ball runner block FLS
- Size 55
- Preload class C1
- Accuracy class H
- With standard seal, without ball chain

Material number:

R1653 513 10

Preload classes

- C0 = Without preload (clearance)
- C1 = Moderate preload
- C2 = Average preload
- C3 = High preload

Seals

SS = Standard seal

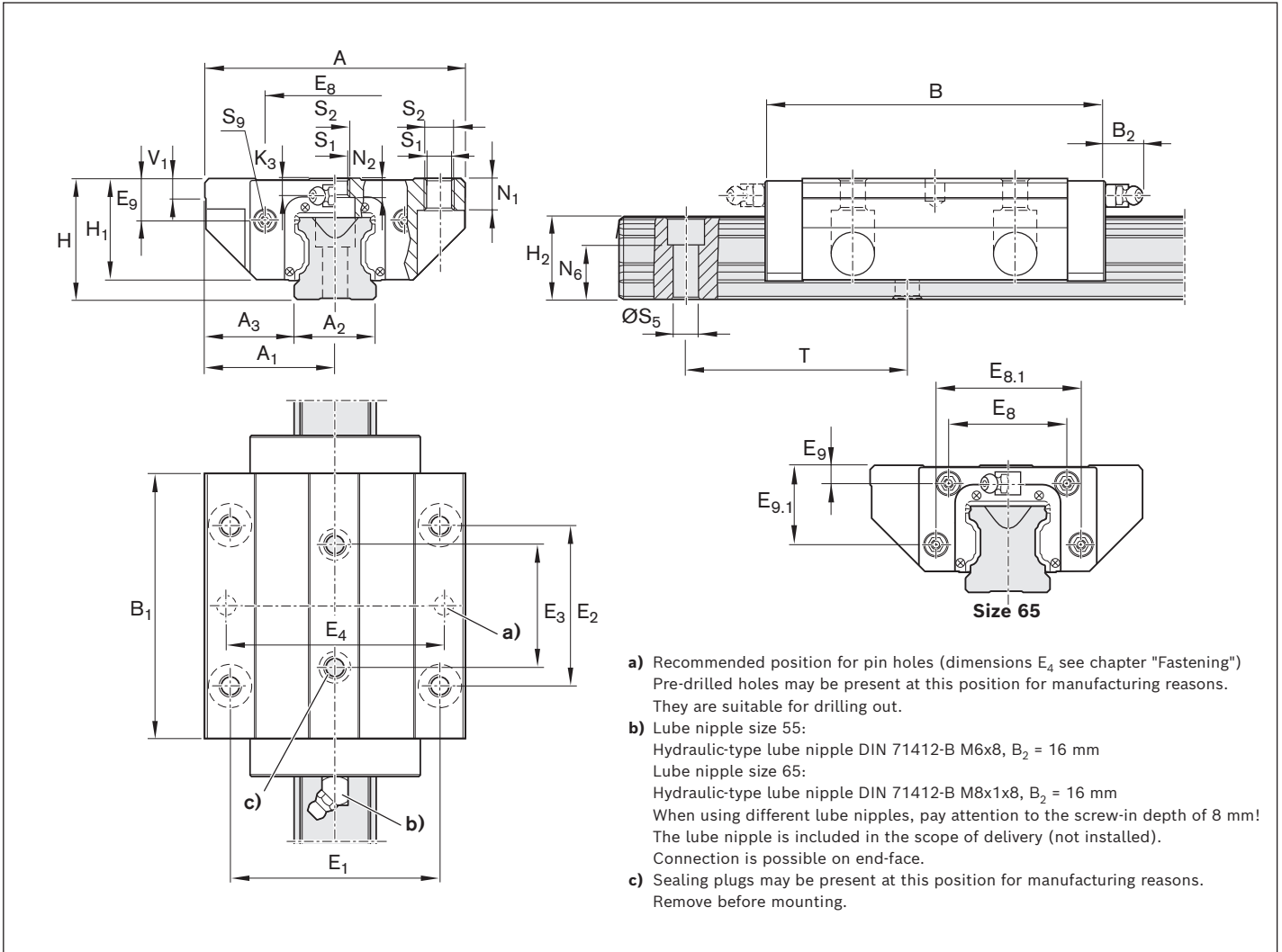

Size	Dimensions (mm)																
	A	A ₁	A ₂	A ₃	B ^{+0.5}	B ₁	E ₁	E ₂	E ₃	E ₈	E _{8.1}	E ₉	E _{9.1}	H	H ₁	H ₂ ¹⁾	H ₂ ²⁾
55	140	70	53	43.5	199	155.5	116	95	70	80	-	22.3	-	70	57	48.15	47.85
65	170	85	63	53.5	243	194.6	142	110	82	76	100	11.0	53.5	90	76	60.15	59.85

Size	Dimensions (mm)											Mass (kg)	Load capacities ³⁾ (N)		Load moments ³⁾ (Nm)			
	K ₃	N ₁	N ₂	N ₆ ^{±0.5}	S ₁	S ₂	S ₅	S ₉	T	V ₁	m		C	C ₀	M _t	M _{t0}	M _L	M _{L0}
55	9	18	13.5	29.0	12.4	M14	16	M5x8	120	12	7.50	139000	245000	4410	7780	3960	6990	
65	16	23	14.0	38.5	14.6	M16	18	M4x7	150	15	14.15	223000	404000	8810	16000	8160	14800	

- 1) Dimension H_2 with cover strip
- 2) Dimension H_2 without cover strip
- 3) Load capacities and load moments for ball runner block **without** ball chain.
Determination of the dynamic load capacities and load moments is based on a stroke travel of 100,000 m according to DIN ISO 14728-1.
Often only 50,000 m are actually stipulated. For comparison: Multiply the values **C**, **M_t** and **M_L** by 1.26 according to the table.

SNS – Slimline, normal, standard height, R1622...1.

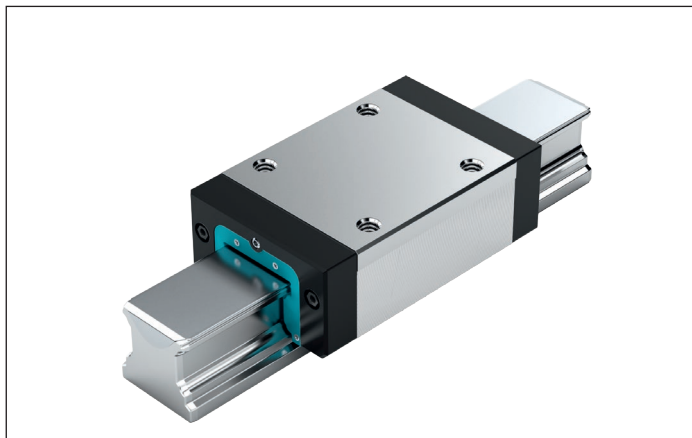

Dynamic characteristics

Speed: $v_{max} = 3 \text{ m/s}$
 Acceleration: $a_{max} = 250 \text{ m/s}^2$
 (If $F_{comb} > 2.8 \cdot F_{pr}$: $a_{max} = 50 \text{ m/s}^2$)

Note on lubrication

► No initial lubrication

Note

Can be used on all SNS ball guide rails.

Options and material numbers

Size	Ball runner block with size	Preload class				Accuracy class			Seal on ball runner block without ball chain	
		C0	C1	C2	C3	N	H	P	SS	
55	R1622 5	9				4	3	-		10
			1			4	3	2		10
				2		-	3	2		10
					3	-	-	2		10
65	R1622 6	9				4	3	-		10
			1			4	3	2		10
				2		-	3	2		10
					3	-	-	2		10
E.g.:	R1622 5		1				3			10

Ordering example

Options:

- Ball runner block SNS
- Size 55
- Preload class C1
- Accuracy class H
- With standard seal, without ball chain

Preload classes

C0 = Without preload (clearance)
 C1 = Moderate preload
 C2 = Average preload
 C3 = High preload

Seals

SS = Standard seal

Material number:

R1622 513 10

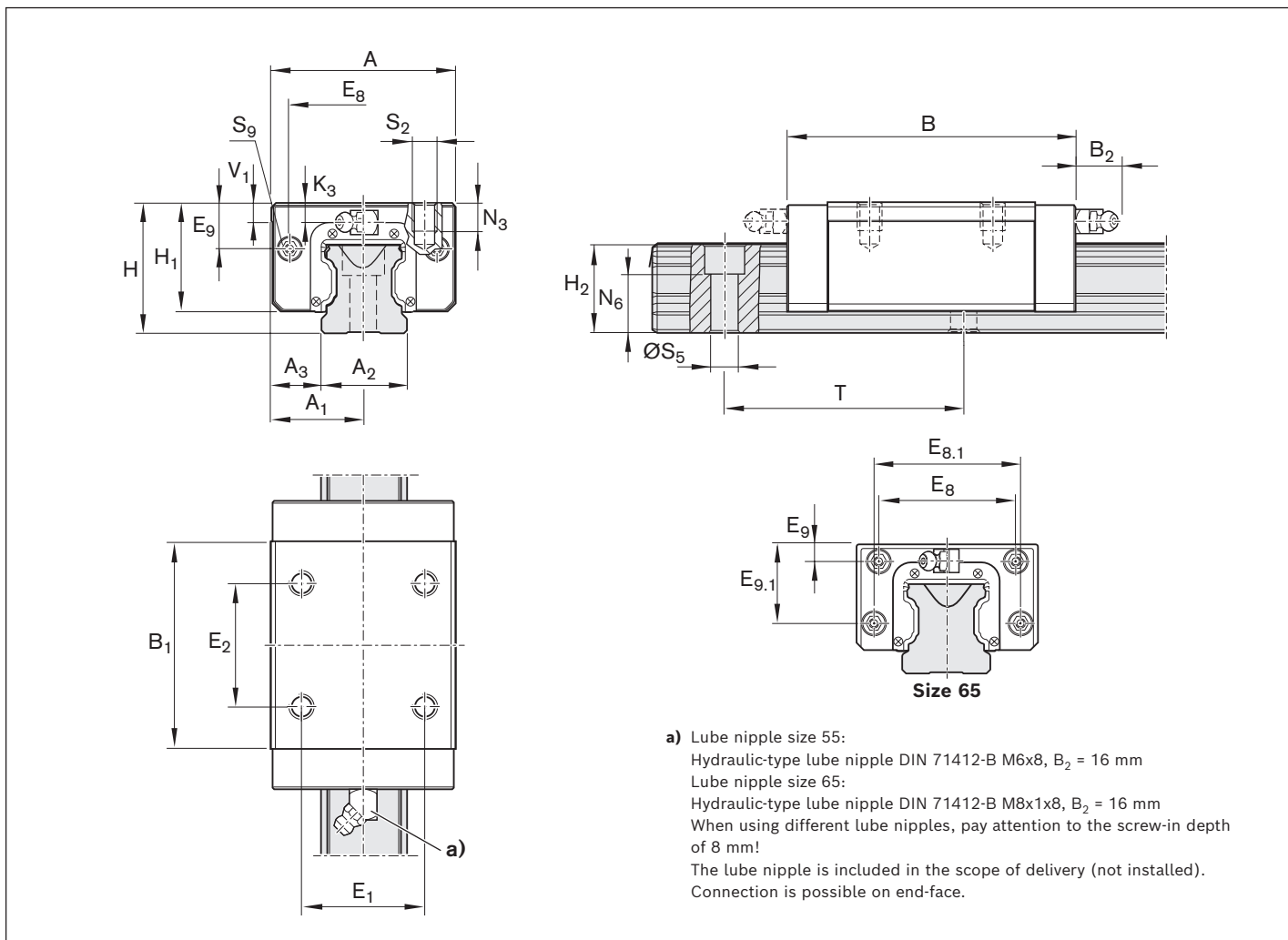

a) Lube nipple size 55:
 Hydraulic-type tube nipple DIN 71412-B M6x8, B₂ = 16 mm
 Lube nipple size 65:
 Hydraulic-type tube nipple DIN 71412-B M8x1x8, B₂ = 16 mm
 When using different lube nipples, pay attention to the screw-in depth of 8 mm!
 The lube nipple is included in the scope of delivery (not installed).
 Connection is possible on end-face.

Size	Dimensions (mm)															
	A	A ₁	A ₂	A ₃	B ^{+0.5}	B ₁	E ₁	E ₂	E ₈	E _{8.1}	E ₉	E _{9.1}	H	H ₁	H ₂ ¹⁾	H ₂ ²⁾
55	100	50	53	23.5	159	115.5	75	75	80	-	22.3	-	70	57	48.15	47.85
65	126	63	63	31.5	188	139.6	76	70	76	100	11.0	53.5	90	76	60.15	59.85

Size	Dimensions (mm)								Mass (kg)	Load capacities ³⁾ (N)		Load moments ³⁾ (Nm)			
	K ₃	N ₃	N ₆ ^{±0.5}	S ₂	S ₅	S ₉	T	V ₁		m	C	C ₀	M _t	M _{t0}	M _L
55	9	19	29.0	M12	16	M5x8	120	12	3.80	109000	174000	3480	5550	2320	3690
65	16	21	38.5	M16	18	M4x7	150	15	6.90	172000	280000	6810	11100	4560	7400

- 1) Dimension H₂ with cover strip
- 2) Dimension H₂ without cover strip
- 3) Load capacities and load moments for ball runner block **without** ball chain.
 Determination of the dynamic load capacities and load moments is based on a stroke travel of 100,000 m according to DIN ISO 14728-1. Often only 50,000 m are actually stipulated. For comparison: Multiply the values **C**, **M_t** and **M_L** by 1.26 according to the table.

SLS – Slimline, long, standard height, R1623...1.

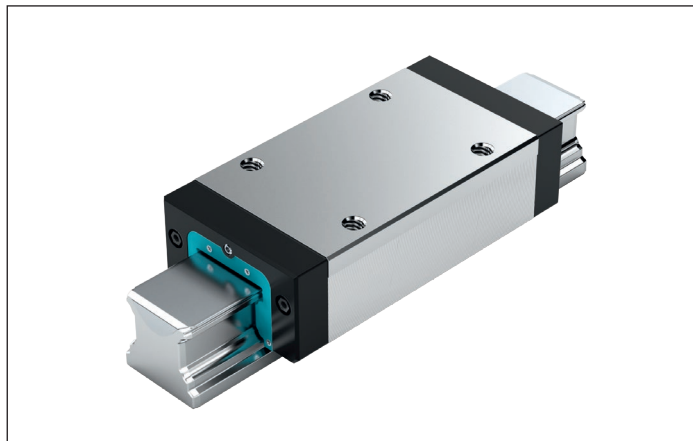

Dynamic characteristics

Speed: $v_{max} = 3 \text{ m/s}$
 Acceleration: $a_{max} = 250 \text{ m/s}^2$
 (If $F_{comb} > 2.8 \cdot F_{pr}$: $a_{max} = 50 \text{ m/s}^2$)

Note on lubrication

► No initial lubrication

Note

Can be used on all SNS ball guide rails.

Options and material numbers

Size	Ball runner block with size	Preload class				Accuracy class			Seal on ball runner block without ball chain	
		C0	C1	C2	C3	N	H	P	SS	
55	R1623 5	9				4	3	-	10	
			1			4	3	2	10	
				2		-	3	2	10	
					3	-	-	2	10	
65	R1623 6	9				4	3	-	10	
			1			4	3	2	10	
				2		-	3	2	10	
					3	-	-	2	10	
E.g.:	R1623 5		1				3		10	

Ordering example

Options:

- Ball runner block SLS
- Size 55
- Preload class C1
- Accuracy class H
- With standard seal, without ball chain

Material number:

R1623 513 10

Preload classes

C0 = Without preload (clearance)
 C1 = Moderate preload
 C2 = Average preload
 C3 = High preload

Seals

SS = Standard seal

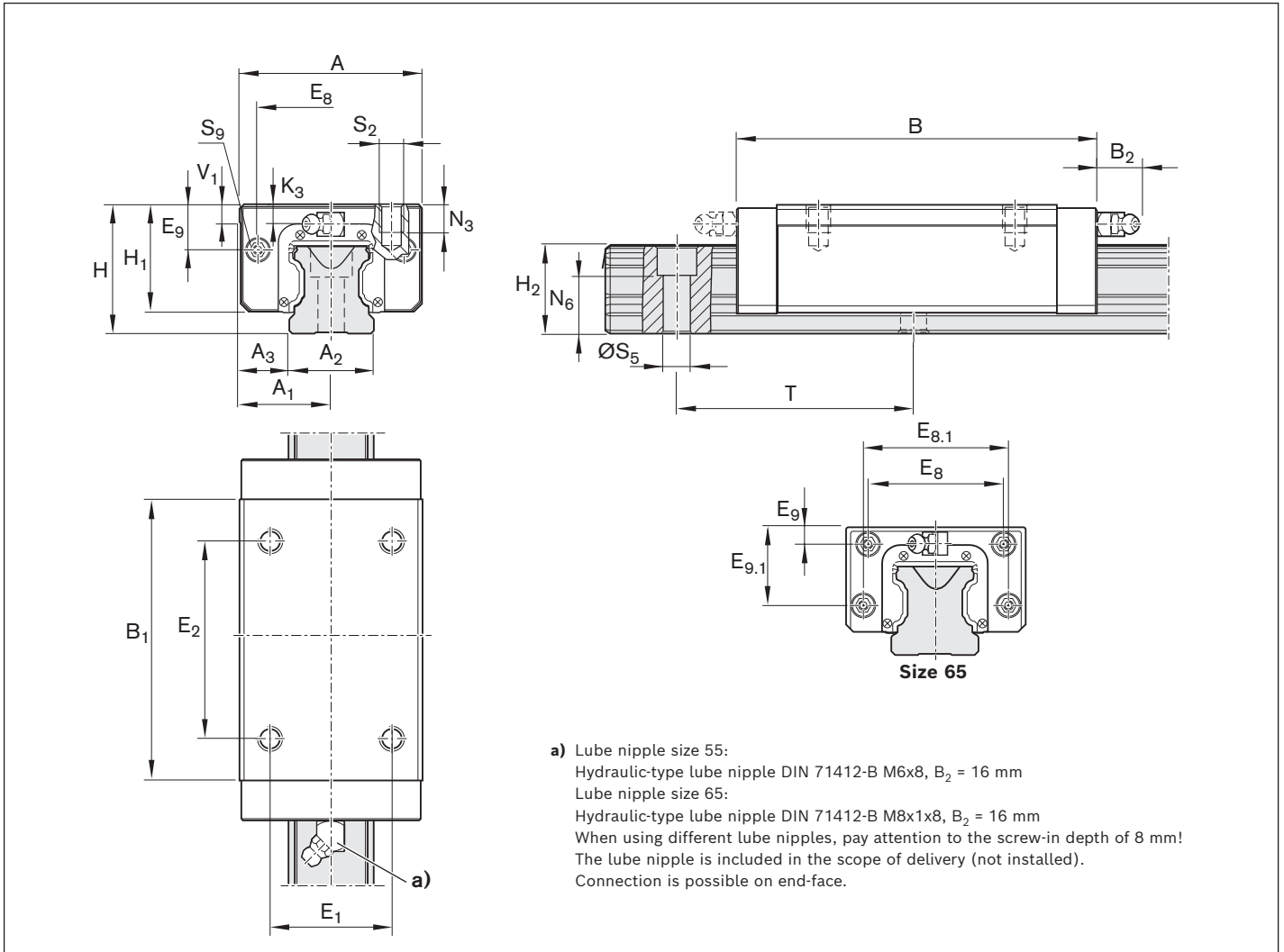

Size	Dimensions (mm)															
	A	A ₁	A ₂	A ₃	B ^{+0.5}	B ₁	E ₁	E ₂	E ₈	E _{8.1}	E ₉	E _{9.1}	H	H ₁	H ₂ ¹⁾	H ₂ ²⁾
55	100	50	53	23.5	199	155.5	75	95	80	-	22.3	-	70	57	48.15	47.85
65	126	63	63	31.5	243	194.6	76	120	76	100	11.0	53.5	90	76	60.15	59.85

Size	Dimensions (mm)									Mass (kg)	Load capacities ³⁾ (N)		Load moments ³⁾ (Nm)			
	K ₃	N ₃	N ₆ ^{±0.5}	S ₂	S ₅	S ₉	T	V ₁	m		C	C ₀	M _t	M _{t0}	M _L	M _{L0}
55	9	19	29.0	M12	16	M5x8	120	12	4.8	139000	245000	4410	7780	3960	6990	
65	16	21	38.5	M16	18	M4x7	150	15	9.8	223000	404000	8810	16000	8160	14800	

- 1) Dimension H₂ with cover strip
- 2) Dimension H₂ without cover strip
- 3) Load capacities and load moments for ball runner block **without** ball chain.
Determination of the dynamic load capacities and load moments is based on a stroke travel of 100,000 m according to DIN ISO 14728-1. Often only 50,000 m are actually stipulated. For comparison: Multiply the values **C**, **M_t** and **M_L** by 1.26 according to the table.

SNH – Slimline, normal, high, R1621 ... 1.

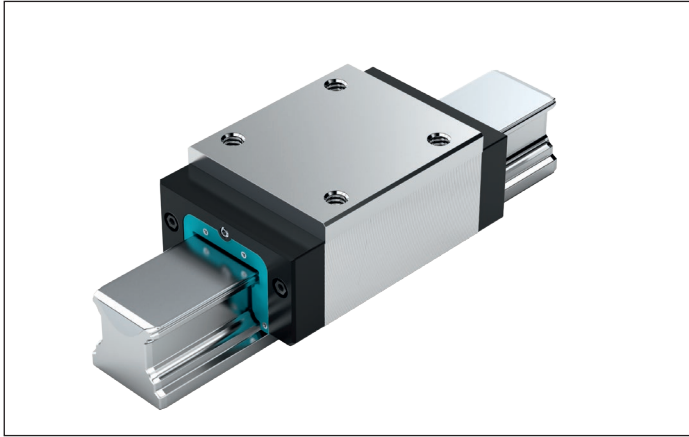

Dynamic characteristics

Speed: $v_{max} = 3 \text{ m/s}$
 Acceleration: $a_{max} = 250 \text{ m/s}^2$
 (If $F_{comb} > 2.8 \cdot F_{pr}$: $a_{max} = 50 \text{ m/s}^2$)

Note on lubrication

▶ No initial lubrication

Note

Can be used on all SNS ball guide rails.

Options and material numbers

Size	Ball runner block with size	Preload class				Accuracy class			Seal on ball runner block without ball chain	
		C0	C1	C2	C3	N	H	P	SS	
55	R1621 5	9				4	3	-	10	
			1			4	3	2	10	
				2		-	3	2	10	
					3	-	-	2	10	
E.g.:	R1621 5		1				3		10	

Ordering example

Options:

- ▶ Ball runner block SNH
- ▶ Size 55
- ▶ Preload class C1
- ▶ Accuracy class H
- ▶ With standard seal, without ball chain

Material number: R1621 513 10

Preload classes

- C0 = Without preload (clearance)
- C1 = Moderate preload
- C2 = Average preload
- C3 = High preload

Seals

SS = Standard seal

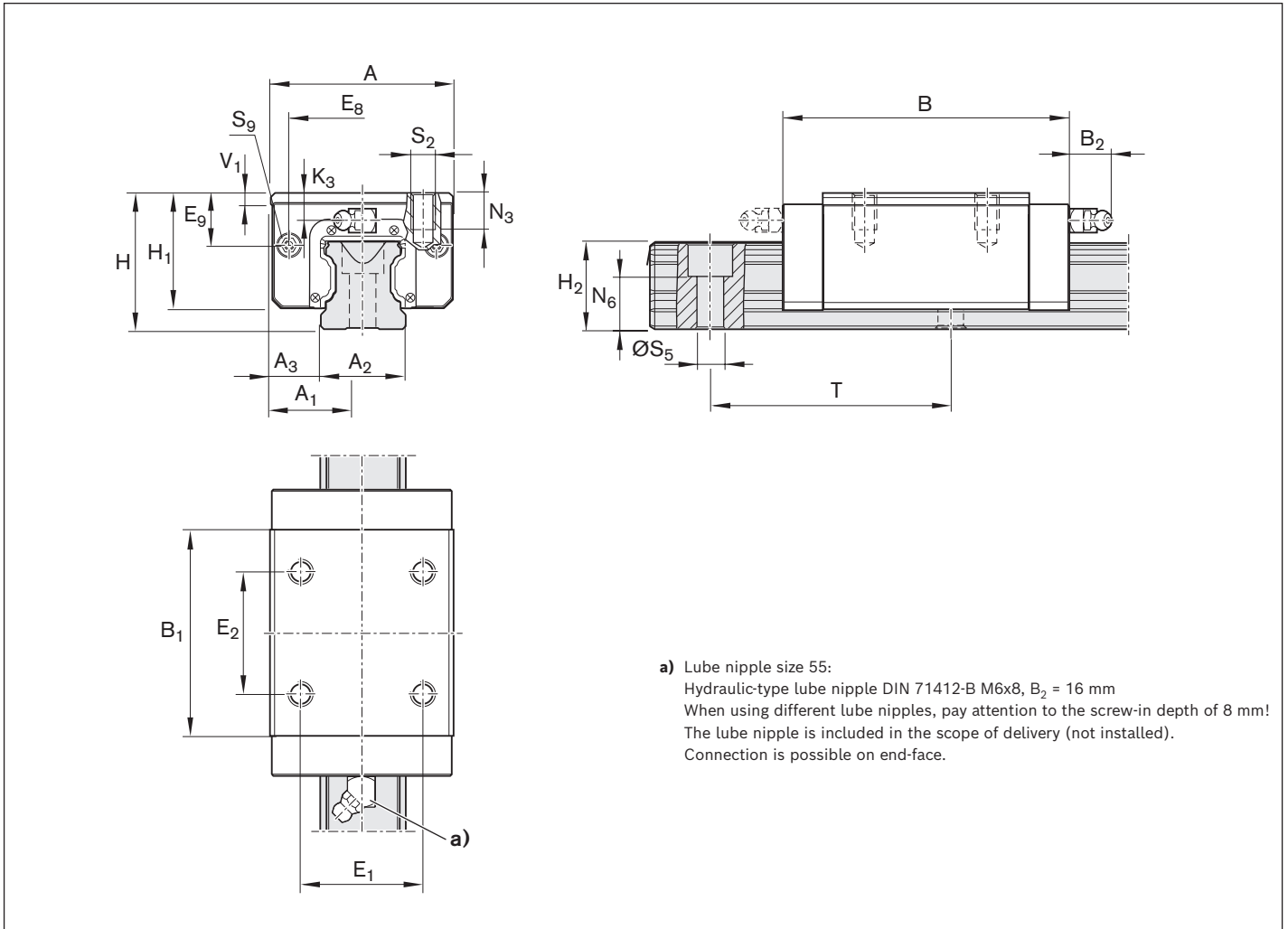

Size	Dimensions (mm)													
	A	A ₁	A ₂	A ₃	B ^{+0.5}	B ₁	E ₁	E ₂	E ₈	E ₉	H	H ₁	H ₂ ¹⁾	H ₂ ²⁾
55	100	50	53	23.5	159	115.5	75	75	80	32.3	80	67	48.15	47.85

Size	Dimensions (mm)								Mass (kg)	Load capacities ³⁾ (N)		Load moments ³⁾ (Nm)			
	K ₃	N ₃	N ₆ ^{±0.5}	S ₂	S ₅	S ₉	T	V ₁		m	C	C ₀	M _t	M _{t0}	M _L
55	19	19	29	M12	16	M5x8	120	12	4.70	109000	174000	3480	5550	2320	3690

- 1) Dimension H₂ with cover strip
- 2) Dimension H₂ without cover strip
- 3) Load capacities and load moments for ball runner block **without** ball chain.
 Determination of the dynamic load capacities and load moments is based on a stroke travel of 100,000 m according to DIN ISO 14728-1. Often only 50,000 m are actually stipulated. For comparison: Multiply the values **C**, **M_t** and **M_L** by 1.26 according to the table.

SLH – Slimline, long, high, R1624 ... 1.

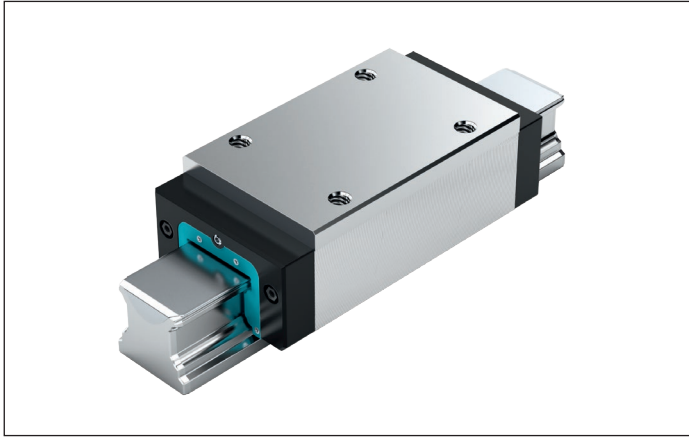

Dynamic characteristics

Speed: $v_{max} = 3 \text{ m/s}$
 Acceleration: $a_{max} = 250 \text{ m/s}^2$
 (If $F_{comb} > 2.8 \cdot F_{pr}$: $a_{max} = 50 \text{ m/s}^2$)

Note on lubrication

▶ No initial lubrication

Note

Can be used on all SNS ball guide rails.

Options and material numbers

Size	Ball runner block with size	Preload class				Accuracy class			Seal on ball runner block without ball chain	SS
		C0	C1	C2	C3	N	H	P		
55	R1624 5	9				4	3	-	10	
			1			4	3	2	10	
				2		-	3	2	10	
					3	-	-	2	10	
E.g.:	R1624 5		1				3		10	

Ordering example

Options:

- ▶ Ball runner block SLH
- ▶ Size 55
- ▶ Preload class C1
- ▶ Accuracy class H
- ▶ With standard seal, without ball chain

Material number:

R1624 513 10

Preload classes

- C0 = Without preload (clearance)
- C1 = Moderate preload
- C2 = Average preload
- C3 = High preload

Seals

SS = Standard seal

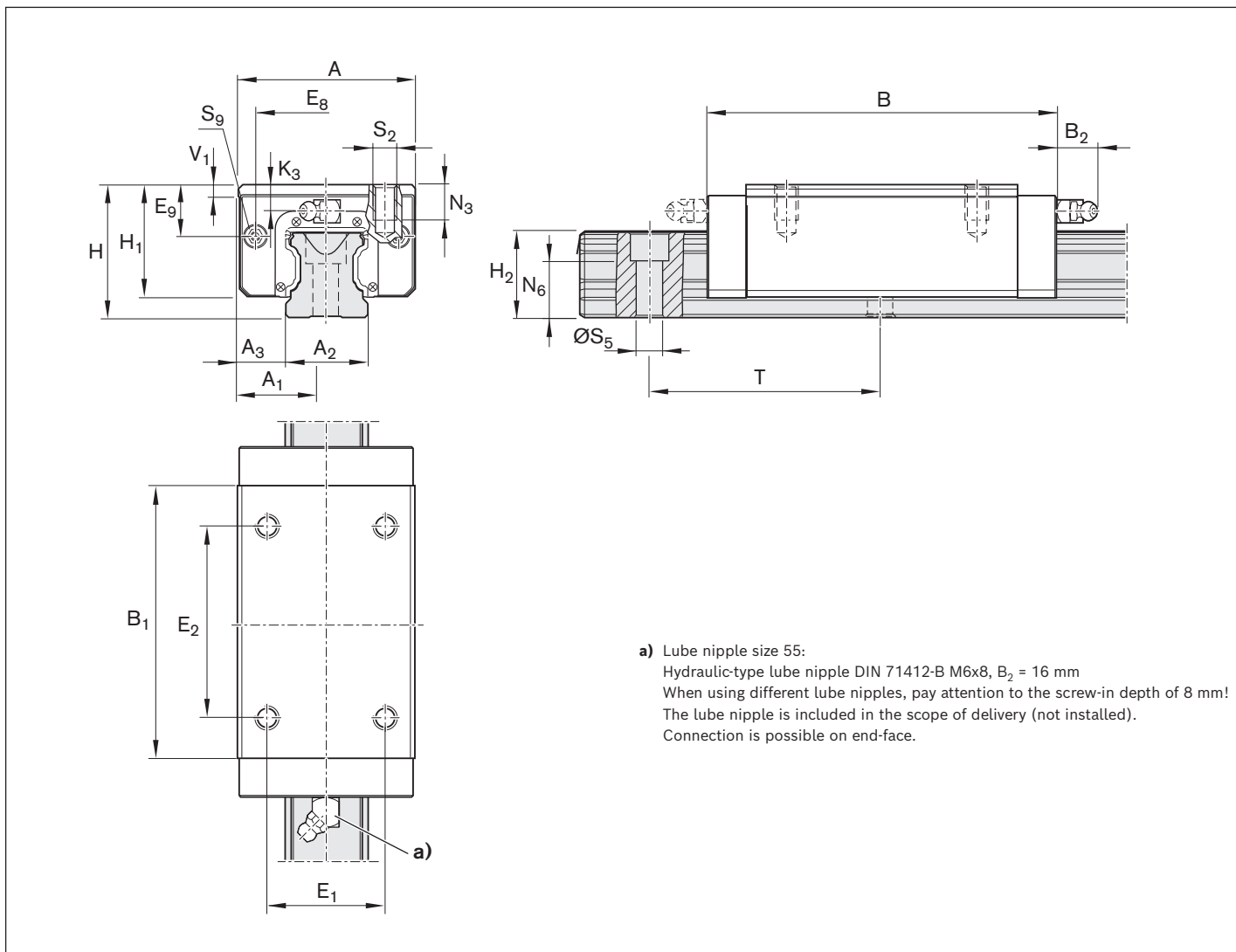

Size	Dimensions (mm)													
	A	A ₁	A ₂	A ₃	B ^{+0.5}	B ₁	E ₁	E ₂	E ₈	E ₉	H	H ₁	H ₂ ¹⁾	H ₂ ²⁾
55	100	50	53	23.5	199	155.5	75	95	80	32.3	80	67	48.15	47.85

Size	Dimensions (mm)									Mass (kg)	Load capacities ³⁾ (N)		Load moments ³⁾ (Nm)			
	K ₃	N ₃	N ₆ ^{±0.5}	S ₂	S ₅	S ₉	T	V ₁	m		C	C ₀	M _t	M _{t0}	M _L	M _{L0}
55	19	19	29	M12	16	M5x8	120	12	6.00	139000	245000	4410	7780	3960	6990	

- 1) Dimension H₂ with cover strip
- 2) Dimension H₂ without cover strip
- 3) Load capacities and load moments for ball runner block **without** ball chain.
 Determination of the dynamic load capacities and load moments is based on a stroke travel of 100,000 m according to DIN ISO 14728-1. Often only 50,000 m are actually stipulated. For comparison: Multiply the values **C**, **M_t** and **M_L** by 1.26 according to the table.

Product description

Characteristic features

- ▶ Excellent dynamic characteristics:
Speed $v_{max} = 10 \text{ m/s}$ (size 15 - 45)
 $v_{max} = 5 \text{ m/s}$ (size 65)
- ▶ Acceleration $a_{max} = 500 \text{ m/s}^2$ (size 15 - 45)
 $a_{max} = 250 \text{ m/s}^2$ (size 65)
- ▶ The same high load capacities in all four main directions of loading
- ▶ Long-term lubrication is possible over several years
- ▶ Minimum quantity lubrication system with integrated reservoir for oil lubrication
- ▶ Lube fittings with metal threads on all sides
- ▶ Limitless interchangeability as all ball guide rail systems can be combined at will with all ball runner block versions within each accuracy class.
- ▶ Maximum system rigidity due to preloaded O-arrangement
- ▶ Electrically insulating due to use of ceramic balls for size 15 - 45
- ▶ Existing range of accessories fully usable
- ▶ Globally unique, premium logistics

1) Type-dependent



Ceramic balls (size 15 - 45)

- ▶ Enable maximum travel speeds

Further highlights:

- ▶ High speed due to the low weight of the ceramic balls or by pulse-reducing ball circulation at size 65
- ▶ Attachments on the ball runner block can be bolted from above and below¹⁾
- ▶ Improved rigidity under lift-off and side loading conditions due to two additional mounting screw bores at the center of the ball runner block
- ▶ End-face fastening thread for all attachments
- ▶ High rigidity in all directions of loading – permits applications with just one runner block per rail
- ▶ Integrated all-round sealing
- ▶ High torque load capacity
- ▶ Optimized entry-zone geometry and high number of balls minimize variation in elastic deflection
- ▶ Smooth, quiet running thanks to optimally designed ball return and guideway
- ▶ Available in seven common sizes
- ▶ Ball runner block pre-lubricated at the factory

Definition of the format of ball runner blocks

Criterion	Designation	Code (example)		
		F	N	S
Width	Flange (F)	F		
	Slimline (S)	S		
	Wide (B)	B		
	Compact (C)	C		
Length	Normal (N)		N	
	Long (L)		L	
	Short (K)		K	
Height	Standard height (S)			S
	High (H)			H
	Low (N)			N

Note

Can be used on all SNS/SNO ball guide rails.

Overview of formats

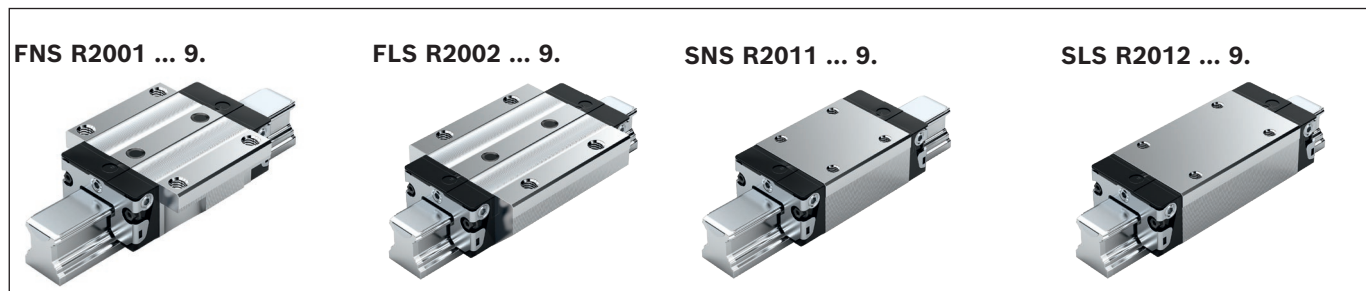

FNS, FLS, SNS, SLS

Format	Size	Ball runner block with size	Preload class			Accuracy class			Seal ball runner block, without ball chain	Load capacities ¹⁾ (N)				Load moments ¹⁾ (Nm)				Mass (kg)	Speed (m/s)	Acceleration (m/s ²)
			C2	H	P	SS	C	C ₀		M _t	M _{t0}	M _L	M _{L0}	m	v _{max}	a _{max}				
FNS	15	R2001 1	2	3	2	90	6880	8860	66	85	47	61	0.20	10	500					
	20	R2001 8	2	3	2	90	16300	20800	210	270	140	180	0.45	10	500					
	25	R2001 2	2	3	2	90	20000	25100	280	360	200	250	0.60	10	500					
	30	R2001 7	2	3	2	90	25500	33500	440	580	310	400	1.05	10	500					
	35	R2001 3	2	3	2	90	36200	56500	780	1210	510	790	1.50	10	500					
	45	R2001 4	2	3	2	90	60300	92100	1630	2490	1070	1640	2.85	10	500					
E.g.:		R2001 7	2	3		90														
FLS	15	R2002 1	2	3	2	90	8930	12800	86	120	85	120	0.30	10	500					
	20	R2002 8	2	3	2	90	20700	29200	260	370	240	340	0.55	10	500					
	25	R2002 2	2	3	2	90	26000	36600	370	520	370	520	0.80	10	500					
	30	R2002 7	2	3	2	90	32100	46700	560	810	520	750	1.45	10	500					
	35	R2002 3	2	3	2	90	46600	81100	1000	1740	900	1560	2.15	10	500					
	45	R2002 4	2	3	2	90	77700	132000	2100	3570	1910	3250	4.10	10	500					
65	R1653 6	2	-	2	90	223000	404000	8810	16000	8160	14800	14.15	5	250						
SNS	15	R2011 1	2	3	2	90	6880	8860	66	85	47	61	0.15	10	500					
	20	R2011 8	2	3	2	90	16300	20800	210	270	140	180	0.35	10	500					
	25	R2011 2	2	3	2	90	20000	25100	280	360	200	250	0.45	10	500					
	30	R2011 7	2	3	2	90	25500	33500	440	580	310	400	0.80	10	500					
	35	R2011 3	2	3	2	90	36200	56500	780	1210	510	790	1.15	10	500					
	45	R2011 4	2	3	2	90	60300	92100	1630	2490	1070	1640	2.25	10	500					
SLS	15	R2012 1	2	3	2	90	8930	12800	86	120	85	120	0.20	10	500					
	20	R2012 8	2	3	2	90	20700	29200	260	370	240	340	0.45	10	500					
	25	R2012 2	2	3	2	90	26000	36600	370	520	370	520	0.60	10	500					
	30	R2012 7	2	3	2	90	32100	46700	560	810	520	750	1.05	10	500					
	35	R2012 3	2	3	2	90	46600	81100	1000	1740	900	1560	1.60	10	500					
	45	R2012 4	2	3	2	90	77700	132000	2100	3570	1910	3250	3.00	10	500					
65	R1623 6	2	-	2	90	223000	404000	8810	16000	8160	14800	9.8	5	250						

1) Load capacities and load moments for ball runner block **without** ball chain.
 Determination of the dynamic load capacities and load moments is based on a stroke travel of 100,000 m according to DIN ISO 14728-1.
 Often only 50,000 m are actually stipulated. For comparison: Multiply the values **C**, **M_t** and **M_L** by 1.26 according to the table.

Note

Dimensions, dimension drawing, load capacities, rigidity and moments see standard ball runner block BSHP

Ordering example FNS

Options:

- ▶ Ball runner block FNS
- ▶ Size 30
- ▶ Preload class C2
- ▶ Accuracy class H
- ▶ With standard seal, without ball chain

Material number:

R2001 723 90

Preload classes

C2 = Average preload

Seals

SS = Standard seal

Product description

Characteristic features

- ▶ Compensates own misalignments (for deviations up to 10' in 2 levels)
- ▶ Extra-compact design
- ▶ The same high load capacities in all four main directions of loading
- ▶ Enables greater parallelism and vertical offsets of mounting bases
- ▶ Accuracy classes H and N
- ▶ Preload classes:
C0 (without preload, clearance)
C1 (moderate preload)
- ▶ Smooth operation due to optimal return and ball pick-up and entry design
- ▶ Low noise level and outstanding travel behavior
- ▶ Excellent dynamic characteristics:
Travel speed: $v_{max} = 5 \text{ m/s}$
Acceleration: $a_{max} = 500 \text{ m/s}^2$
- ▶ Minimum quantity lubrication system with integrated reservoir for oil lubrication
- ▶ Lube fittings with metal threads on all sides
- ▶ Ball runner block pre-lubricated at the factory
- ▶ Limitless interchangeability as all ball guide rail systems can be combined at will with all ball runner block versions within each accuracy class.

Self-aligning

Rexroth super ball runner blocks with self-aligning feature automatically compensate misalignments up to 10 ft. No reduction in load capacity occurs as a result of angular pressure.

The centers of the mating surfaces supporting the steel bearing plates serve as a rocking fulcrum. Misalignments between ball runner blocks and ball guide rails are therefore not problematic since machining inaccuracies, mounting errors or rail deflections are automatically compensated.

The self-aligning feature ensures that the balls enter the load-bearing zone smoothly and that the load is distributed evenly across the entire row of balls. This results in extra-smooth running and considerably longer service life.

Using two super ball runner blocks on one ball guide rail, a system of high-load bearing and stabilized ball rail systems can be created that is particularly suitable for the handling sector.

Two runner blocks must always be mounted on one rail.

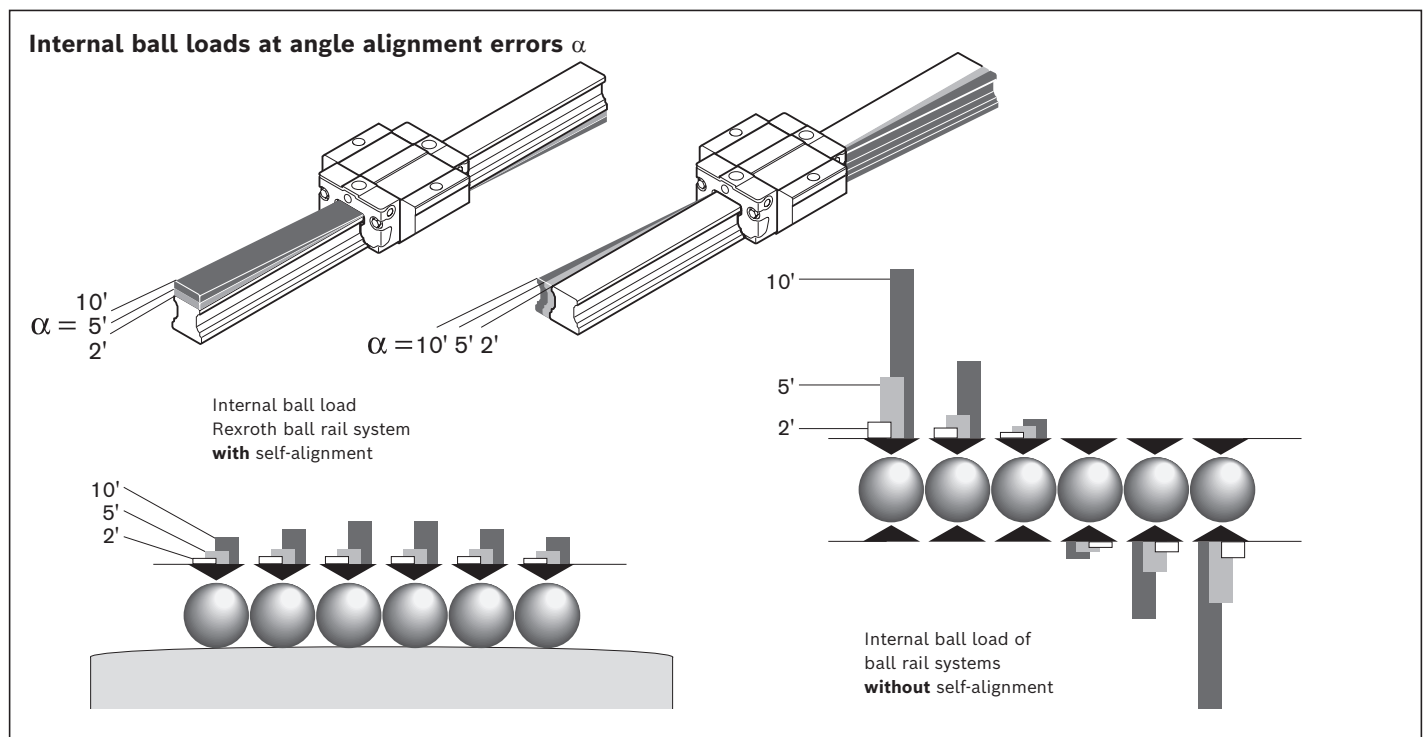

Overview of formats

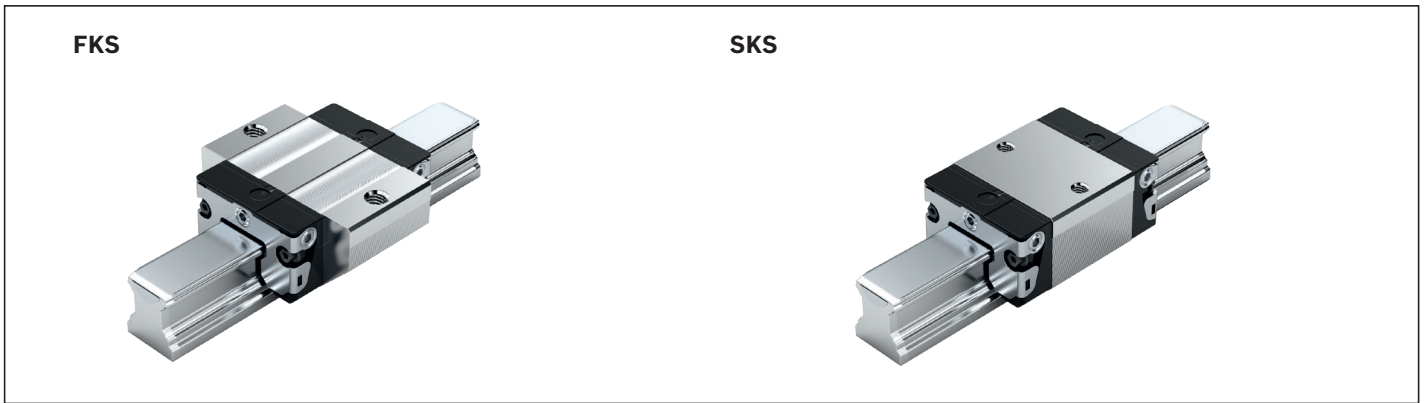

Definition of the format of ball runner blocks

Criterion	Designation	Code (example)		
		F	K	S
Width	Flange (F)	F		
	Slimline (S)	S		
	Wide (B)	B		
	Compact (C)	C		
Length	Normal (N)		N	
	Long (L)		L	
	Short (K)		K	
Height	Standard height (S)			S
	High (H)			H
	Low (N)			N

FKS – Flange, short, standard height

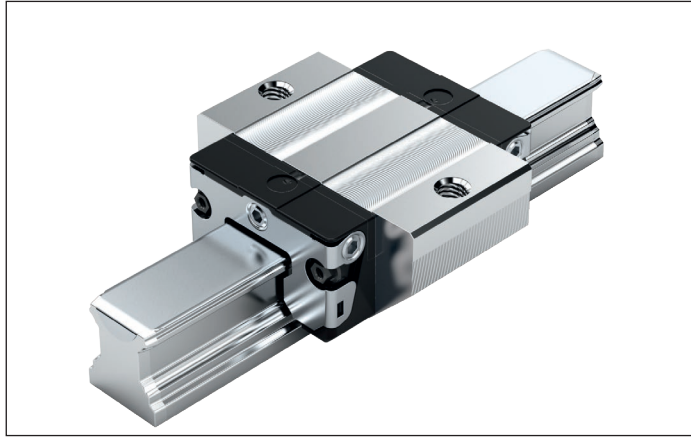

R1661 ... 2.

Dynamic characteristics

Speed: $v_{\max} = 5 \text{ m/s}$
 Acceleration: $a_{\max} = 500 \text{ m/s}^2$
 (If $F_{\text{comb}} > 2.8 \cdot F_{\text{pr}}$: $a_{\max} = 50 \text{ m/s}^2$)

Note on lubrication

► Pre-lubricated

Note

Can be used on all SNS ball guide rails.

Options and material numbers

Size	Ball runner block with size	Preload class		Accuracy class		Seal on ball runner block without ball chain	
		C0	C1	N	H	SS	LS
15	R1661 1	9	1	4	3	20	21
20	R1661 8	9	1	4	3	20	21
25	R1661 2	9	1	4	3	20	21
30	R1661 7	9	1	4	3	20	21
35	R1661 3	9	1	4	3	20	21
E.g.:	R1661 7		1		3	20	

Ordering example

Options:

- Ball runner block FKS
- Size 30
- Preload class C1
- Accuracy class H
- With standard seal, without ball chain

Material number:

R1661 713 20

Preload classes

C0 = Without preload (clearance)
 C1 = Moderate preload

Seals

SS = Standard seal
 LS = Low-friction seal

Key

gray numbers
 = no preferred variant / combination
 (partially longer delivery times)

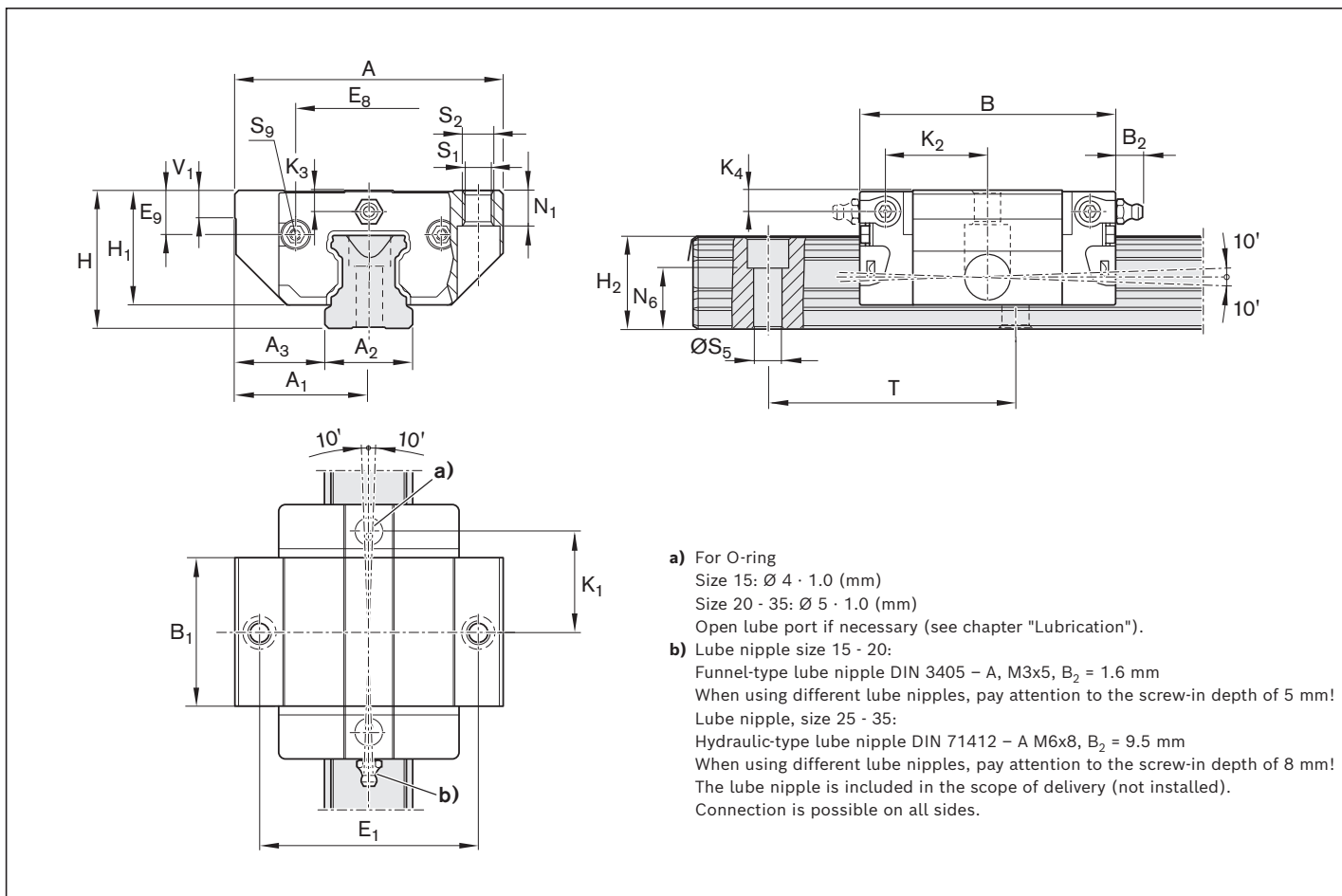

- a) For O-ring
 Size 15: Ø 4 · 1.0 (mm)
 Size 20 - 35: Ø 5 · 1.0 (mm)
 Open lube port if necessary (see chapter "Lubrication").
- b) Lube nipple size 15 - 20:
 Funnel-type lube nipple DIN 3405 – A, M3x5, B₂ = 1.6 mm
 When using different lube nipples, pay attention to the screw-in depth of 5 mm!
 Lube nipple, size 25 - 35:
 Hydraulic-type lube nipple DIN 71412 – A M6x8, B₂ = 9.5 mm
 When using different lube nipples, pay attention to the screw-in depth of 8 mm!
 The lube nipple is included in the scope of delivery (not installed).
 Connection is possible on all sides.

Size	Dimensions (mm)																	
	A	A ₁	A ₂	A ₃	B ^{+0.5}	B ₁	E ₁	E ₈	E ₉	H	H ₁	H ₂ ¹⁾	H ₂ ²⁾	K ₁	K ₂	K ₃	K ₄	
15	47	23.5	15	16.0	44.7	25.7	38	24.55	6.70	24	19.90	16.30	16.20	16.25	17.85	3.20	3.20	
20	63	31.5	20	21.5	57.3	31.9	53	32.50	7.30	30	25.35	20.75	20.55	22.95	22.95	3.35	3.35	
25	70	35.0	23	23.5	67.0	38.6	57	38.30	11.50	36	29.90	24.45	24.25	25.35	26.50	5.50	5.50	
30	90	45.0	28	31.0	75.3	45.0	72	48.40	14.60	42	35.35	28.55	28.35	28.80	30.50	6.05	6.05	
35	100	50.0	34	33.0	84.9	51.4	82	58.00	17.35	48	40.40	32.15	31.85	32.70	34.20	6.90	6.90	

Size	Dimensions (mm)										Weight (kg)	Load capacities ³⁾ (N)	Permissible load (N)	Load moments ³⁾ (Nm)	
	N ₁	N ₆ ^{±0.5}	S ₁	S ₂	S ₅	S ₉	T	V ₁	C	F _{max}				M _t	M _{t max}
15	5.2	10.3	4.3	M5	4.5	M2,5x3,5	60	5.0	0.15	3900	1500	39	15		
20	7.7	13.2	5.3	M6	6.0	M3x5	60	6.0	0.30	10100	3900	130	50		
25	9.3	15.2	6.7	M8	7.0	M3x5	60	7.5	0.50	11400	4400	170	65		
30	11.0	17.0	8.5	M10	9.0	M3x5	80	7.0	0.80	15800	6100	270	105		
35	12.0	20.5	8.5	M10	9.0	M3x5	80	8.0	1.20	21100	8100	450	175		

- 1) Dimension H₂ with cover strip
- 2) Dimension H₂ without cover strip
- 3) Load capacities and load moments for ball runner block **without** ball chain.
 Determination of the dynamic load capacities and load moments is based on a stroke travel of 100,000 m according to DIN ISO 14728-1.
 Often only 50,000 m are actually stipulated. For comparison: Multiply the values **C** and **M_t** by 1.26 according to the table.

SKS – Slimline, short, standard height

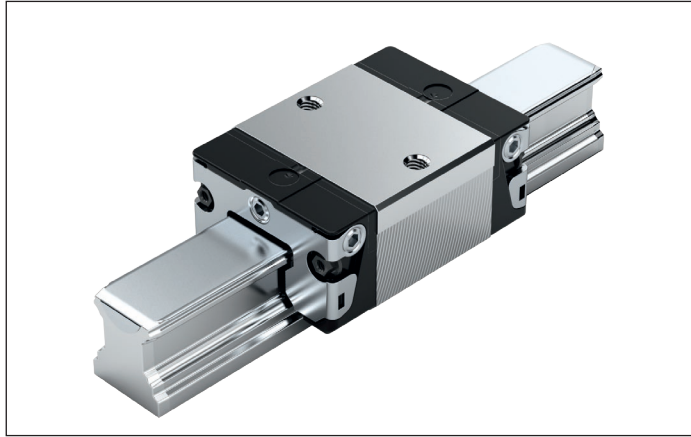

R1662 ... 2.

Dynamic characteristics

Speed: $v_{max} = 5 \text{ m/s}$
 Acceleration: $a_{max} = 500 \text{ m/s}^2$
 (If $F_{comb} > 2.8 \cdot F_{pr}$: $a_{max} = 50 \text{ m/s}^2$)

Note on lubrication

▶ Pre-lubricated

Note

Can be used on all SNS ball guide rails.

Options and material numbers

Size	Ball runner block with size	Preload class		Accuracy class			Seal on ball runner block	
		C0	C1	N	H	without ball chain		
						SS	LS	
15	R1662 1	9	1	4	3	20	21	
20	R1662 8	9	1	4	3	20	21	
25	R1662 2	9	1	4	3	20	21	
30	R1662 7	9	1	4	3	20	21	
35	R1662 3	9	1	4	3	20	21	
E.g.:	R1662 7		1		3	20		

Ordering example

Options:

- ▶ Ball runner block SKS
- ▶ Size 30
- ▶ Preload class C1
- ▶ Accuracy class H
- ▶ With standard seal, without ball chain

Material number:

R1662 713 20

Preload classes

C0 = Without preload (clearance)
 C1 = Moderate preload

Seals

SS = Standard seal
 LS = Low-friction seal

Key

gray numbers
 = no preferred variant / combination
 (partially longer delivery times)

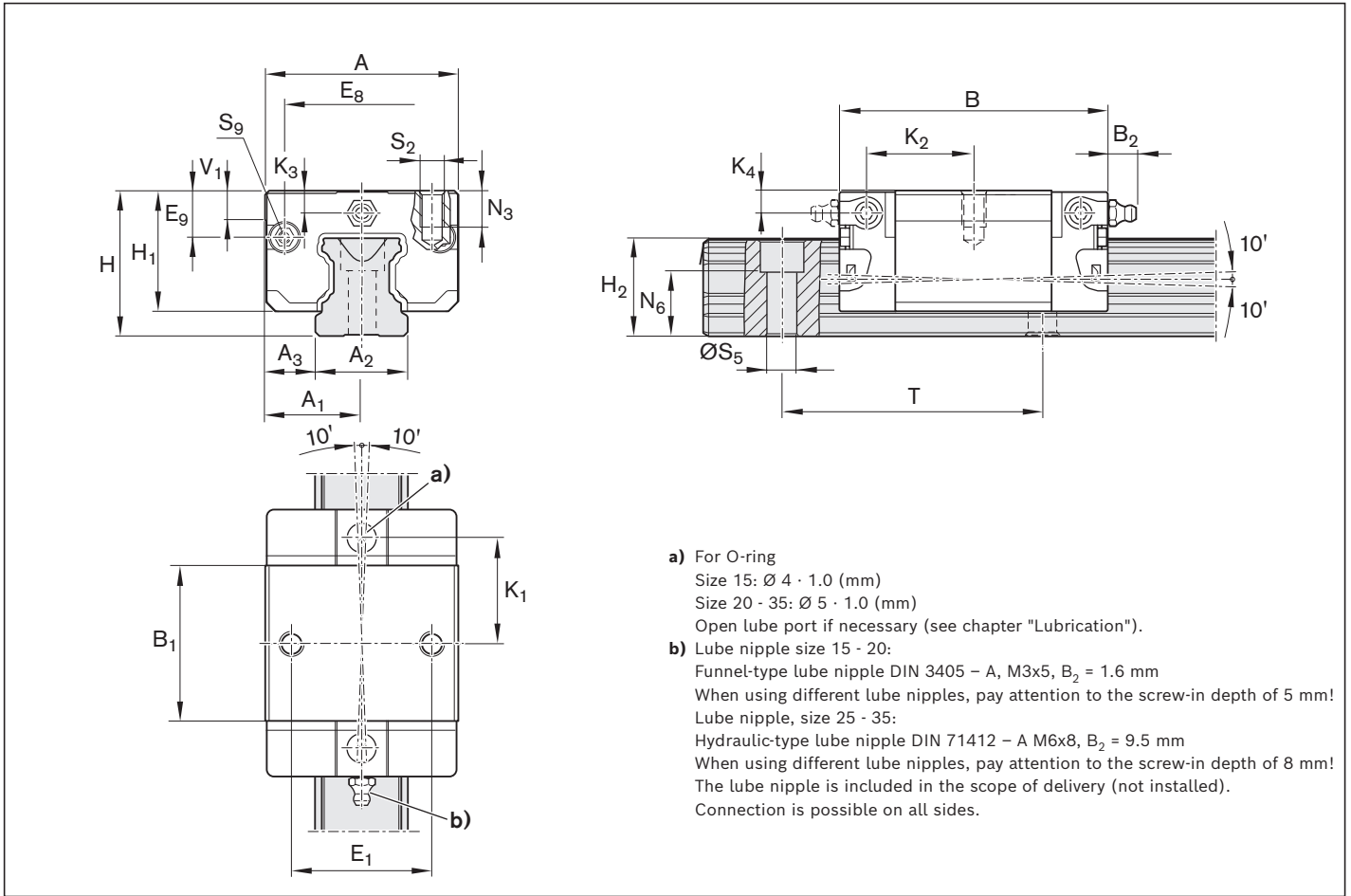

Size	Dimensions (mm)																
	A	A ₁	A ₂	A ₃	B ^{+0.5}	B ₁	E ₁	E ₈	E ₉	H	H ₁	H ₂ ¹⁾	H ₂ ²⁾	K ₁	K ₂	K ₃	K ₄
15	34	17	15	9.5	44.7	25.7	26	24.55	6.70	24	19.90	16.30	16.20	16.25	17.85	3.20	3.20
20	44	22	20	12.0	57.3	31.9	32	32.50	7.30	30	25.35	20.75	20.55	22.95	22.95	3.35	3.35
25	48	24	23	12.5	67.0	38.6	35	38.30	11.50	36	29.90	24.45	24.25	25.35	26.50	5.50	5.50
30	60	30	28	16.0	75.3	45.0	40	48.40	14.60	42	35.35	28.55	28.35	28.80	30.50	6.05	6.05
35	70	35	34	18.0	84.9	51.4	50	58.00	17.35	48	40.40	32.15	31.85	32.70	34.20	6.90	6.90

Size	Dimensions (mm)								Mass (kg)	Load capacities ³⁾ (N)	Permissible load (N)	Load moments ³⁾ (Nm)	
	N ₃	N ₆ ^{±0.5}	S ₂	S ₅	S ₉	T	V ₁	C				F _{max}	M _t
15	6.0	10.3	M4	4.5	M2,5x3,5	60	5.0	0.10	3900	1500	39	15	
20	7.5	13.2	M5	6.0	M3x5	60	6.0	0.25	10100	3900	130	50	
25	9.0	15.2	M6	7.0	M3x5	60	7.5	0.35	11400	4400	170	65	
30	12.0	17.0	M8	9.0	M3x5	80	7.0	0.60	15800	6100	270	105	
35	13.0	20.5	M8	9.0	M3x5	80	8.0	0.90	21100	8100	450	175	

- 1) Dimension H₂ with cover strip
- 2) Dimension H₂ without cover strip
- 3) Load capacities and load moments for ball runner block **without** ball chain.
 Determination of the dynamic load capacities and load moments is based on a stroke travel of 100,000 m according to DIN ISO 14728-1. Often only 50,000 m are actually stipulated. For comparison: Multiply the values **C** and **M_t** by 1.26 according to the table.

Product description

Characteristic features

Rexroth ball rail systems with aluminum ball runner blocks have been developed specially for industrial robots and general machine building requiring compact, ball bearing-mounted longitudinal guides in various accuracy classes with very high load-bearing capacity and low gravity.

The extremely small and lightweight guide units in five common sizes have the same high load capacities in all four main directions of loading.

Highlights

- ▶ High torque load capacity
- ▶ Optimized entry-zone geometry and high number of balls minimize variation in elastic deflection
- ▶ Extra-compact lightweight design 60% less weight due to aluminum compared to the ball runner blocks made of steel
- ▶ Limitless interchangeability as all ball guide rail systems can be combined at will with all ball runner block versions within each accuracy class.

Further highlights

- ▶ Low noise level and outstanding travel behavior
- ▶ Excellent dynamic characteristics:
Travel speed: $v_{\max} = 5 \text{ m/s}$
Acceleration: $a_{\max} = 500 \text{ m/s}^2$
- ▶ Long-term lubrication is possible over several years
- ▶ Minimum quantity lubrication with integrated reservoir for oil lubrication
- ▶ Enables greater parallelism and vertical offsets of mounting bases
- ▶ Accuracy classes H and N are combinable with all rails in each accuracy class
- ▶ Lube connection with metal thread on all sides
- ▶ End-face fastening thread for all attachments
- ▶ Ball guide rails of accuracy class H are also available with surface protection Resist CR (matt silver finish, hard chrome plated)
- ▶ Quiet, smooth running thanks to optimally designed ball and ball chain return and guideway
- ▶ Improved rigidity under lift-off and side loading conditions due to two additional mounting screw bores at the center of the ball runner block¹⁾
- ▶ Attachments on the ball runner block can be bolted from above and below¹⁾
- ▶ Predrilled holes on the ball runner block for pinning
- ▶ Optionally available with ball chain
- ▶ Ball runner block pre-lubricated at the factory

1) Type-dependent

Overview

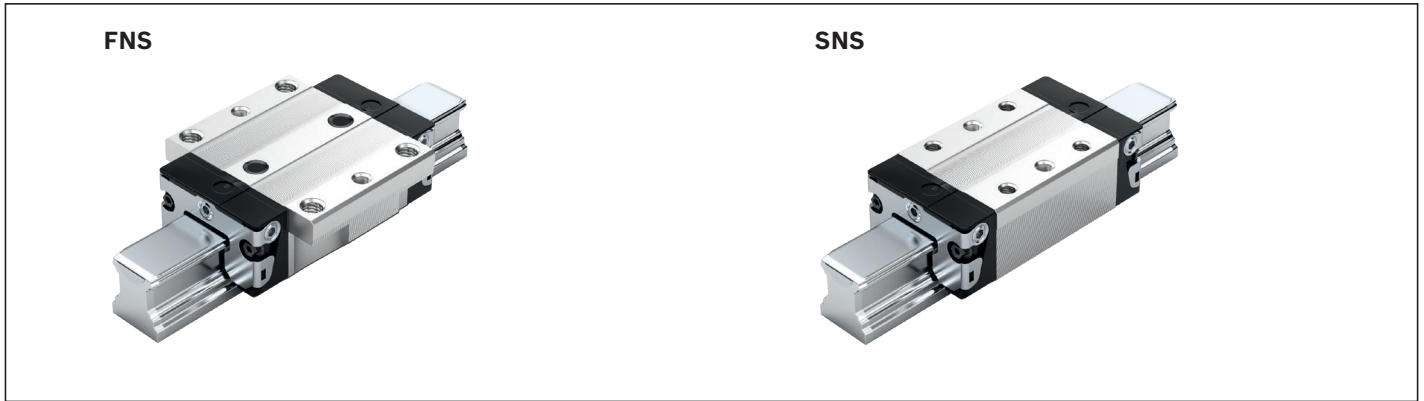

Definition of the format of ball runner blocks

Criterion	Designation	Code (example)		
		F	N	S
Width	Flange (F)	F		
	Slimline (S)	S		
	Wide (B)	B		
	Compact (C)	C		
Length	Normal (N)		N	
	Long (L)		L	
	Short (K)		K	
Height	Standard height (S)			S
	High (H)			H
	Low (N)			N



Ball chain (optional)

- ▶ Optimized noise level

FNS – Flange, normal, standard height, R1631 ... 2.

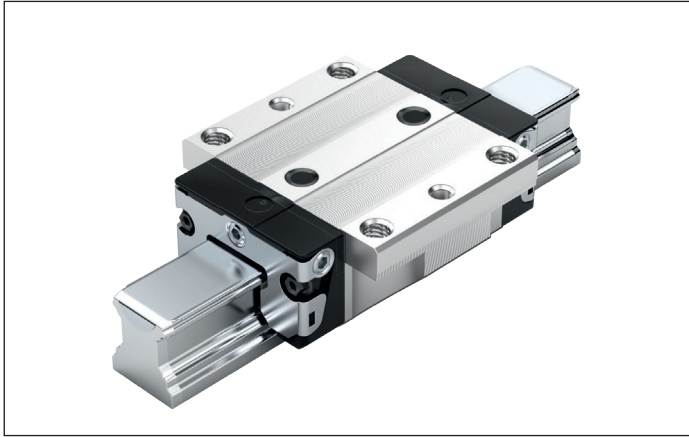

R1631 ... 2.

Dynamic characteristics

Speed: $v_{max} = 5 \text{ m/s}$
 Acceleration: $a_{max} = 500 \text{ m/s}^2$
 (If $F_{comb} > 2.8 \cdot F_{pr}$: $a_{max} = 50 \text{ m/s}^2$)

Note on lubrication

▶ Pre-lubricated

Note

Can be used on all SNS ball guide rails.

Options/material numbers/technical data

Size	Ball runner block with size	Preload class		Accuracy class		Seal on ball runner block			
		C0	C1	N	H	without ball chain		with ball chain	
						SS	LS	SS	LS
15	R1631 1	9	1	4	3	20	21	22	23
20	R1631 8	9	1	4	3	20	21	22	23
25	R1631 2	9	1	4	3	20	21	22	23
30	R1631 7	9	1	4	3	20	21	22	23
35	R1631 3	9	1	4	3	20	21	22	23
E.g.:	R1631 7		1		3	20			

Size	Load capacities ¹⁾ (N)	Permissible load (N)		Load moments ¹⁾ (Nm)			
	 C	F_{max}	M_t	$M_{t max}$	M_L	$M_{L max}$	
15	9860	3000	95	29	68	16	
20	23400	7200	300	92	200	50	
25	28600	8800	410	125	290	70	
30	36500	12200	630	210	440	110	
35	51800	16200	1110	345	720	170	

1) Load capacities and load moments for ball runner block **without** ball chain.

Load capacities and load moments for ball runner block **with** ball chain 13

Determination of the dynamic load capacities and load moments is based on a stroke travel of 100,000 m according to DIN ISO 14728-1. Often only 50,000 m are actually stipulated. For comparison: Multiply the values **C**, **M_t** and **M_L** by 1.26 according to the table.

Ordering example

Options:

- ▶ Ball runner block FNS
- ▶ Size 30
- ▶ Preload class C1
- ▶ Accuracy class H
- ▶ With standard seal, without ball chain

Material number:

R1631 713 20

Preload classes

C0 = Without preload (clearance)
 C1 = Moderate preload

Seals

SS = Standard seal
 LS = Low-friction seal

Key

gray numbers
 = no preferred variant / combination
 (partially longer delivery times)

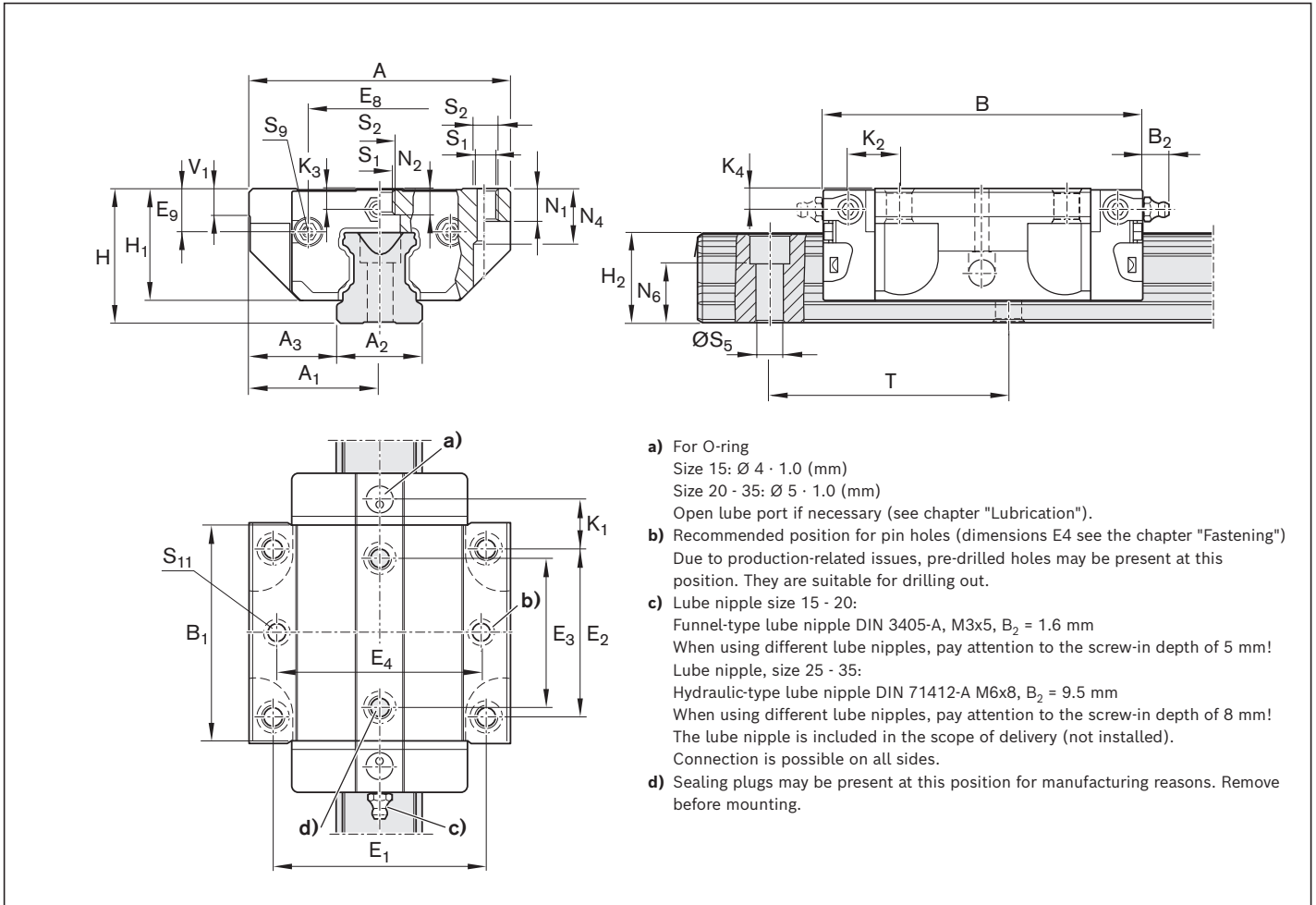

- a) For O-ring
 Size 15: $\varnothing 4 \cdot 1.0$ (mm)
 Size 20 - 35: $\varnothing 5 \cdot 1.0$ (mm)
 Open lube port if necessary (see chapter "Lubrication").
- b) Recommended position for pin holes (dimensions E4 see the chapter "Fastening")
 Due to production-related issues, pre-drilled holes may be present at this position. They are suitable for drilling out.
- c) Lube nipple size 15 - 20:
 Funnel-type lube nipple DIN 3405-A, M3x5, $B_2 = 1.6$ mm
 When using different lube nipples, pay attention to the screw-in depth of 5 mm!
 Lube nipple, size 25 - 35:
 Hydraulic-type lube nipple DIN 71412-A M6x8, $B_2 = 9.5$ mm
 When using different lube nipples, pay attention to the screw-in depth of 8 mm!
 The lube nipple is included in the scope of delivery (not installed).
 Connection is possible on all sides.
- d) Sealing plugs may be present at this position for manufacturing reasons. Remove before mounting.

Size	Dimensions (mm)																		
	A	A ₁	A ₂	A ₃	B ^{+0.5}	B ₁	E ₁	E ₂	E ₃	E ₈	E ₉	H	H ₁	H ₂ ¹⁾	H ₂ ²⁾	K ₁	K ₂	K ₃	K ₄
15	47	23.5	15	16.0	58.2	39.2	38	30	26	24.55	6.70	24	19.90	16.30	16.20	8.00	9.6	3.20	3.20
20	63	31.5	20	21.5	75.0	49.6	53	40	35	32.50	7.30	30	25.35	20.75	20.55	11.80	11.8	3.35	3.35
25	70	35.0	23	23.5	86.2	57.8	57	45	40	38.30	11.50	36	29.90	24.45	24.25	12.45	13.6	5.50	5.50
30	90	45.0	28	31.0	97.7	67.4	72	52	44	48.40	14.60	42	35.35	28.55	28.35	14.00	15.7	6.05	6.05
35	100	50.0	34	33.0	110.5	77.0	82	62	52	58.00	17.35	48	40.40	32.15	31.85	14.50	16.0	6.90	6.90

Size	Dimensions (mm)											Mass (kg)
	N ₁	N ₂	N ₄	N ₆ ^{±0.5}	S ₁	S ₂	S ₅	S ₉	S ₁₁	T	V ₁	
15	5.2	4.40	10.3	10.3	4.3	M5	4.5	M2,5x3,5	3.7	60	5.0	0.10
20	7.7	5.20	13.5	13.2	5.3	M6	6.0	M3x5	4.7	60	6.0	0.24
25	9.3	7.00	17.8	15.2	6.7	M8	7.0	M3x5	5.7	60	7.5	0.30
30	11.0	7.90	20.5	17.0	8.5	M10	9.0	M3x5	7.7	80	7.0	0.55
35	12.0	10.15	24.0	20.5	8.5	M10	9.0	M3x5	7.7	80	8.0	0.75

- 1) Dimension H₂ with cover strip
- 2) Dimension H₂ without cover strip

SNS – Slimline, normal, standard height, R1632 ... 2.

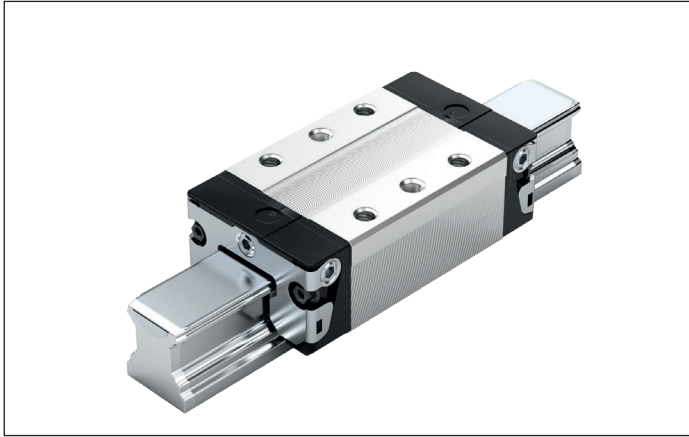

R1632 ... 2.

Dynamic characteristics

Speed: $v_{max} = 5 \text{ m/s}$
 Acceleration: $a_{max} = 500 \text{ m/s}^2$
 (If $F_{comb} > 2.8 \cdot F_{pr}$: $a_{max} = 50 \text{ m/s}^2$)

Note on lubrication

► Pre-lubricated

Note

Can be used on all SNS ball guide rails.

Options/material numbers/technical data

Size	Ball runner block with size	Preload class		Accuracy class		Seal on ball runner block			
		C0	C1	N	H	without ball chain		with ball chain	
						SS	LS	SS	LS
15	R1632 1	9	1	4	3	20	21	22	23
20	R1632 8	9	1	4	3	20	21	22	23
25	R1632 2	9	1	4	3	20	21	22	23
30	R1632 7	9	1	4	3	20	21	22	23
35	R1632 3	9	1	4	3	20	21	22	23
E.g.:	R1632 7		1		3	20			

Size	Load capacities ¹⁾ (N)	Permissible load (N)	Load moments ¹⁾ (Nm)			
	C		F_{max}	M_t	$M_{t max}$	M_L
15	9860	3000	95	29	68	16
20	23400	7200	300	92	200	50
25	28600	8800	410	125	290	70
30	36500	12200	630	210	440	110
35	51800	16200	1110	345	720	170

1) Load capacities and load moments for ball runner block **without** ball chain.

Load capacities and load moments for ball runner block **with** ball chain  13

Determination of the dynamic load capacities and load moments is based on a stroke travel of 100,000 m according to DIN ISO 14728-1.

Often only 50,000 m are actually stipulated. For comparison: Multiply the values **C**, **M_t** and **M_L** by 1.26 according to the table.

Ordering example

Options:

- Ball runner block SNS
- Size 30
- Preload class C1
- Accuracy class H
- With standard seal, without ball chain

Material number:

R1632 713 20

Preload classes

C0 = Without preload (clearance)
 C1 = Moderate preload

Seals

SS = Standard seal
 LS = Low-friction seal

Key

gray numbers
 = no preferred variant / combination
 (partially longer delivery times)

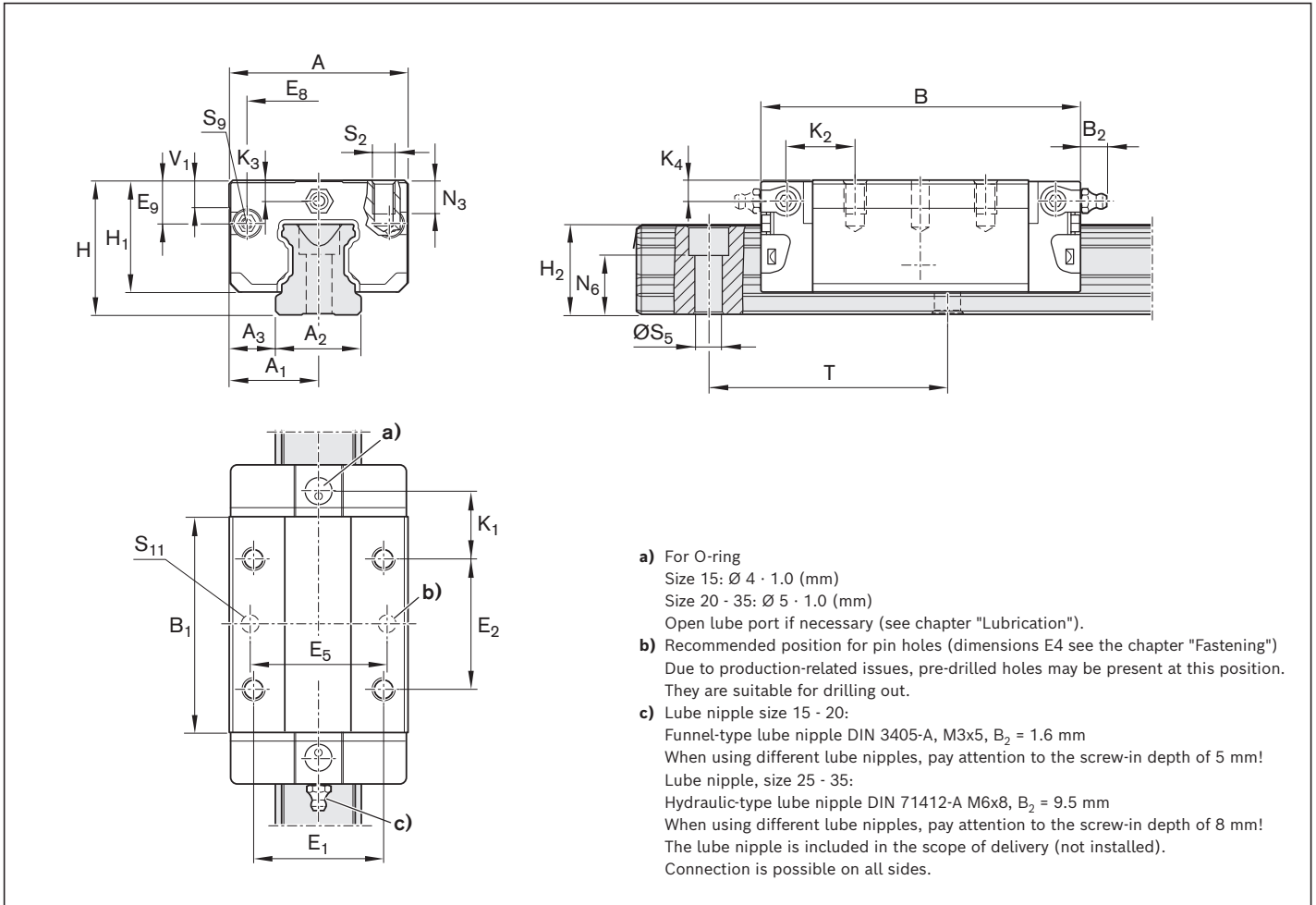

Size	Dimensions (mm)																		
	A	A ₁	A ₂	A ₃	B ^{+0.5}	B ₁	E ₁	E ₂	E ₈	E ₉	H	H ₁	H ₂ ¹⁾	H ₂ ²⁾	K ₁	K ₂	K ₃	K ₄	
15	34	17	15	9.5	58.2	39.2	26	26	24.55	6.70	24	19.90	16.30	16.20	10.00	11.60	3.20	3.20	
20	44	22	20	12.0	75.0	49.6	32	36	32.50	7.30	30	25.35	20.75	20.55	13.80	13.80	3.35	3.35	
25	48	24	23	12.5	86.2	57.8	35	35	38.30	11.50	36	29.90	24.45	24.25	17.45	18.60	5.50	5.50	
30	60	30	28	16.0	97.7	67.4	40	40	48.40	14.60	42	35.35	28.55	28.35	20.00	21.70	6.05	6.05	
35	70	35	34	18.0	110.5	77.0	50	50	58.00	17.35	48	40.40	32.15	31.85	20.50	22.00	6.90	6.90	

Size	Dimensions (mm)									Mass (kg)
	N ₃	N ₆ ^{+0.5}	S ₂	S ₅	S ₉	S ₁₁	T	V ₁		
15	6.0	10.3	M4	4.5	M2,5x3,5	3.7	60	5.0	0.10	
20	7.5	13.2	M5	6.0	M3x5	4.7	60	6.0	0.20	
25	9.0	15.2	M6	7.0	M3x5	5.7	60	7.5	0.35	
30	12.0	17.0	M8	9.0	M3x5	7.7	80	7.0	0.45	
35	13.0	20.5	M8	9.0	M3x5	7.7	80	8.0	0.65	

- 1) Dimension H₂ with cover strip
- 2) Dimension H₂ without cover strip

Product description

General notes on corrosion-resistant ball runner blocks Resist NR

- ▶ As Resist NR is not a coating, all dimensions and tolerances, dynamic characteristics, load capacities, rigidity and moments are identical to the standard steel version.
For material numbers, please refer to the following page.
- ▶ Can be used on all SNS/SNO ball guide rails.
- ▶ Ball runner block body made of corrosion-resistant steel as per DIN EN 10088 Version recommended by Rexroth if corrosion protection is required. Fast delivery.
- ▶ Pre-lubricated

Overview of formats

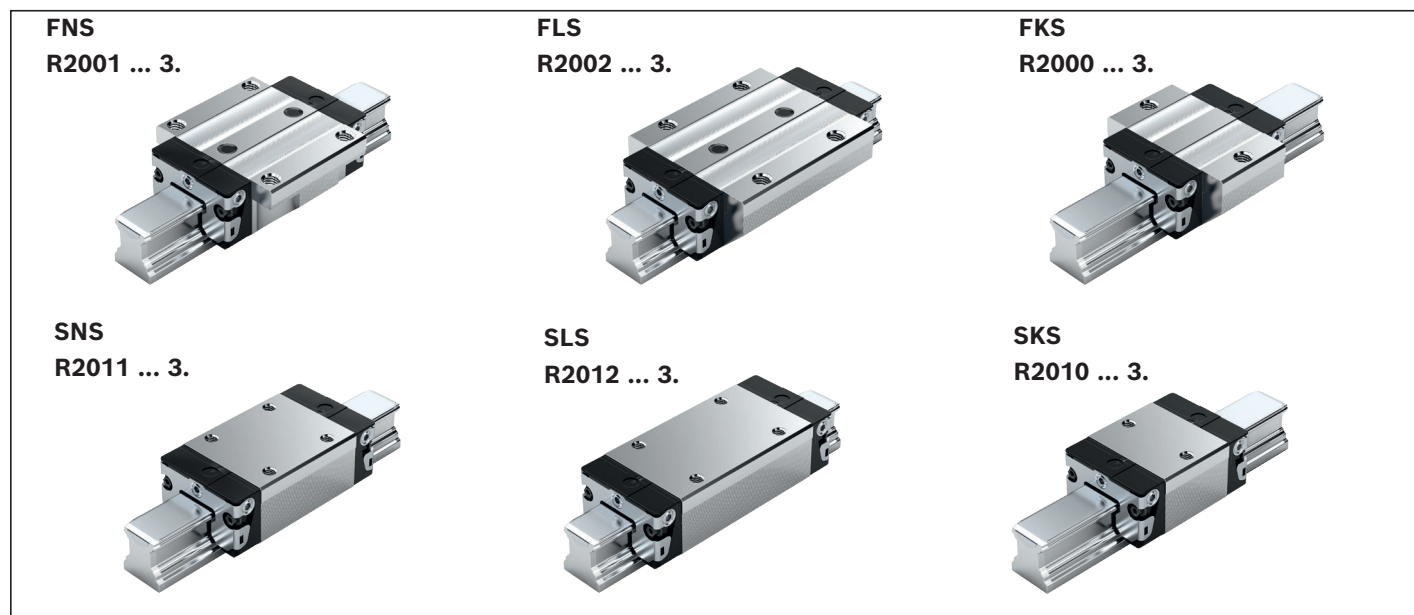

Definition of the format of ball runner blocks

Criterion	Designation	Code (example)		
		F	N	S
Width	Flange (F)	F		
	Slimline (S)			S
	Wide (B)	B		
	Compact (C)	C		
Length	Normal (N)		N	
	Long (L)		L	
	Short (K)		K	
Height	Standard height (S)			S
	High (H)			H
	Low (N)			N



Ball chain (optional)

- ▶ Optimized noise level

FNS, FLS, FKS, SNS, SLS, SKS

Format	Size	Ball runner block with size	Preload class		Accuracy class	Seal on ball runner block						
			C0	C1		without ball chain			with ball chain			
					H	SS	LS	DS	SS	LS	DS	
FNS	15	R2001 1	9	-	3	30	31	-	32	33	-	
	20	R2001 8	9	-	3	30	31	-	32	33	-	
	25	R2001 2	9	-	3	30	31	-	32	33	-	
	30	R2001 7	9		1	3	30	31	-	32	33	-
						3	30	31	3Z	32	33	3Y
	35	R2001 3	9			3	30	31	-	32	33	-
					3	30	31	3Z	32	33	3Y	
E.g.:		R2001 7		1	3	30						
FLS	15	R2002 1	9	-	3	30	31	-	32	33	-	
	20	R2002 8	9	-	3	30	31	-	32	33	-	
	25	R2002 2	9	-	3	30	31	-	32	33	-	
	30	R2002 7	9		1	3	30	31	-	32	33	-
						3	30	31	3Z	32	33	3Y
	35	R2002 3	9			3	30	31	-	32	33	-
				1	3	30	31	3Z	32	33	3Y	
FKS	15	R2000 1	9	-	3	30	31	-	32	33	-	
	20	R2000 8	9	-	3	30	31	-	32	33	-	
	25	R2000 2	9	-	3	30	31	-	32	33	-	
	30	R2000 7	9		1	3	30	31	-	32	33	-
						3	30	31	3Z	32	33	3Y
	35	R2000 3	9			3	30	31	-	32	33	-
				1	3	30	31	3Z	32	33	3Y	
SNS	15	R2011 1	9	-	3	30	31	-	32	33	-	
	20	R2011 8	9	-	3	30	31	-	32	33	-	
	25	R2011 2	9	-	3	30	31	-	32	33	-	
	30	R2011 7	9		1	3	30	31	-	32	33	-
						3	30	31	3Z	32	33	3Y
	35	R2011 3	9			3	30	31	-	32	33	-
				1	3	30	31	3Z	32	33	3Y	
SLS	15	R2012 1	9		3	30	31	-	32	33	-	
	20	R2012 8	9		3	30	31	-	32	33	-	
	25	R2012 2	9		3	30	31	-	32	33	-	
	30	R2012 7	9		1	3	30	31	-	32	33	-
						3	30	31	3Z	32	33	3Y
	35	R2012 3	9			3	30	31	-	32	33	-
				1	3	30	31	3Z	32	33	3Y	
SKS	15	R2010 1	9	-	3	30	31	-	32	33	-	
	20	R2010 8	9	-	3	30	31	-	32	33	-	
	25	R2010 2	9	-	3	30	31	-	32	33	-	
	30	R2010 7	9		1	3	30	31	-	32	33	-
						3	30	31	3Z	32	33	3Y
	35	R2010 3	9			3	30	31	-	32	33	-
				1	3	30	31	3Z	32	33	3Y	

Ordering example FNS

Options:

- ▶ Ball runner block BSHP Resist NR, FNS
- ▶ Size 30
- ▶ Preload class C1
- ▶ Accuracy class H
- ▶ With standard seal, without ball chain

Material number: R2001 713 30

Note

Dimensions, dimension drawing, load capacities, rigidity and moments see standard ball runner block BSHP

Preload classes

- C0 = Without preload (clearance)
- C1 = Moderate preload

Seals

- SS = Standard seal
- LS = Low-friction seal
- DS = Double-lip seal

Key

gray numbers
= no preferred variant / combination
(partially longer delivery times)

Product description

Characteristic features

Ball rail systems Resist NR II made of corrosion-resistant steel¹⁾ are used specifically in conjunction with water-based media, heavily diluted acidic materials, alkali or saline solutions. These guides are also ideally suitable for use at relative humidities above 70% and temperatures exceeding 30 °C.

Such conditions are found mainly in cleaning plants, electroplating and pickling lines, vapor degreasing plants and refrigeration systems.

Since no additional corrosion protection is required, ball rail systems Resist NR II are ideally suited for use in clean rooms and general printed circuit board manufacturing. They are also suitable for other applications in the general packaging industry.

General notes on ball runner blocks Resist NR II

- ▶ Can be used on all SNS ball guide rails, not initially lubricated, not preserved
- ▶ For dimensions see corresponding ball runner blocks made of steel

Highlights

- ▶ All metal parts are made of corrosion-resistant steel
- ▶ Available in five common sizes
- ▶ Excellent dynamic characteristics:
Travel speed: $v_{\max} = 5 \text{ m/s}$
Acceleration: $a_{\max} = 500 \text{ m/s}^2$
- ▶ The same high load capacities in all four main directions of loading
- ▶ Available in accuracy classes N, H and P, up to preload class C2
- ▶ Long-term lubrication is possible over several years
- ▶ Minimum quantity lubrication system with integrated reservoir for oil lubrication
- ▶ Lube fittings with metal threads on all sides
- ▶ Optionally available with ball chain

1) Resist NR II:

Ball runner block body and ball guide rail as well as all steel parts made of corrosion-resistant steel in accordance with DIN EN 10088

General notes

- ▶ Ball rail systems for sectors of the food industry, see the ball rail systems NFRG catalog R310DE2226 (2011.04).
- ▶ Combinations of different accuracy classes
Combining ball guide rails and ball runner blocks of different accuracy classes results in different tolerances for the dimensions H and A3. See "Accuracy classes and their tolerances."
- ▶ Combinations of different materials
Combining ball guide rails and ball runner blocks made of different materials will change the load capacities, permitted loads and load moments. The lower value must be used in each case.

Further highlights

- ▶ Limitless interchangeability as all ball guide rail systems can be combined at will with all ball runner block versions within each accuracy class (also made of steel, aluminum, Resist NR or Resist CR)
- ▶ Maximum system rigidity due to preloaded O-arrangement
- ▶ Existing range of accessories fully usable
- ▶ Attachments on the ball runner block can be bolted from above and below²⁾
- ▶ Improved rigidity under lift-off and side loading conditions due to two additional mounting screw bores at the center of the ball runner block²⁾
- ▶ End-face fastening thread for all attachments
- ▶ High rigidity in all directions of loading – permits applications with just one runner block per rail
- ▶ Integrated all-round sealing
- ▶ Optimized entry-zone geometry and high number of balls minimize variation in elastic deflection
- ▶ Quiet, smooth running thanks to optimally designed ball and ball chain return and guideway
- ▶ Ball guide rail Resist NR II, with or without cover strip, available for bolting from above and below
- ▶ Ball runner block also available with chrome-plated ball guide rails

2) Type-dependent

Overview of formats

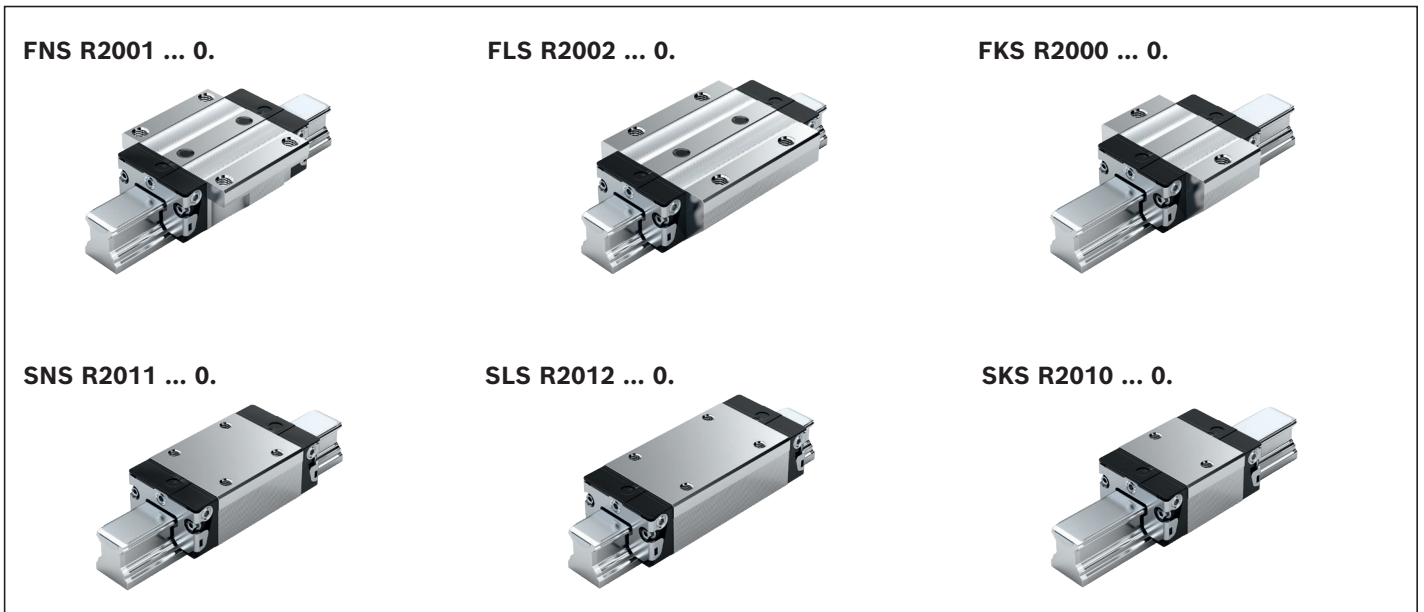

Definition of the format of ball runner blocks

Criterion	Designation	Code (example)		
		F	N	S
Width	Flange (F)	F		
	Slimline (S)	S		
	Wide (B)	B		
	Compact (C)	C		
Length	Normal (N)		N	
	Long (L)		L	
	Short (K)		K	
Height	Standard height (S)			S
	High (H)			H
	Low (N)			N



Ball chain (optional)

- ▶ Optimized noise level

FNS, FLS, FKS, SNS, SLS, SKS

Size	Ball runner block with size	Preload class			Accuracy class			Seal on ball runner block						Mass (kg) m	Load capacities ²⁾ (N)		Load moments ²⁾ (Nm)				
		C0	C1	C2	N	H	P	without ball chain			with ball chain				C	C ₀	M _t	M _{t0}	M _L	M _{L0}	
								SS	LS ¹⁾	DS	SS	LS ¹⁾	DS								
FNS																					
15	R2001 1	9			4	3	-	04	05	-	06	07	-	0.20	5100	9300	63	90	34	49	
			1		4	3	2	04	05	0X	06	07	0W								
				2	-	3	2	04	-	0X	06	-	0W								
20	R2001 8	9			4	3	-	04	05	-	06	07	-	0.45	12300	16900	205	215	110	115	
			1		4	3	2	04	05	0X	06	07	0W								
				2	-	3	2	04	-	0X	06	-	0W								
25	R2001 2	9			4	3	-	04	05	-	06	07	-	0.65	15000	21000	270	295	150	165	
			1		4	3	2	04	05	0X	06	07	0W								
				2	-	3	2	04	-	0X	06	-	0W								
30	R2001 7	9			4	3	-	04	05	-	06	07	-	1.10	20800	28700	460	500	245	265	
			1		4	3	2	04	05	0X	06	07	0W								
				2	-	3	2	04	-	0X	06	-	0W								
35	R2001 3	9			4	3	-	04	05	-	06	07	-	1.60	27600	37500	760	805	375	390	
			1		4	3	2	04	05	0X	06	07	0W								
				2	-	3	2	04	-	0X	06	-	0W								
FLS																					
15	R2002 1	9			4	3	-	04	05	-	06	07	-	0.30	8500	14000	82	132	64	104	
			1		4	3	2	04	05	0X	06	07	0W								
				2	-	3	2	04	-	0X	06	-	0W								
20	R2002 8	9			4	3	-	04	05	-	06	07	-	0.55	16000	24400	265	310	190	230	
			1		4	3	2	04	05	0X	06	07	0W								
				2	-	3	2	04	-	0X	06	-	0W								
25	R2002 2	9			4	3	-	04	05	-	06	07	-	0.90	20000	31600	365	450	290	350	
			1		4	3	2	04	05	0X	06	07	0W								
				2	-	3	2	04	-	0X	06	-	0W								
30	R2002 7	9			4	3	-	04	05	-	06	07	-	1.50	26300	40100	590	695	420	495	
			1		4	3	2	04	05	0X	06	07	0W								
				2	-	3	2	04	-	0X	06	-	0W								
35	R2002 3	9			4	3	-	04	05	-	06	07	-	2.25	36500	56200	1,025	1210	710	840	
			1		4	3	2	04	05	0X	06	07	0W								
				2	-	3	2	04	-	0X	06	-	0W								
FKS																					
15	R2000 1	9			4	3	-	04	05	-	06	07	-	0.15	4500	5600	44	55	16	19	
			1		4	3	-	04	05	0X	06	07	0W								
				-	-	-	-	-	-	-	-	-	-								
20	R2000 8	9			4	3	-	04	05	-	06	07	-	0.30	8200	9400	125	115	45	40	
			1		4	3	-	04	05	0X	06	07	0W								
				-	-	-	-	-	-	-	-	-	-								
25	R2000 2	9			4	3	-	04	05	-	06	07	-	0.50	10500	12600	195	180	70	65	
			1		4	3	-	04	05	0X	06	07	0W								
				-	-	-	-	-	-	-	-	-	-								
30	R2000 7	9			4	3	-	04	05	-	06	07	-	0.80	14500	17200	320	295	110	105	
			1		4	3	-	04	05	0X	06	07	0W								
				-	-	-	-	-	-	-	-	-	-								
35	R2000 3	9			4	3	-	04	05	-	06	07	-	1.20	19300	22400	545	485	170	150	
			1		4	3	-	04	05	0X	06	07	0W								
				-	-	-	-	-	-	-	-	-	-								

Ordering example

Options:

- ▶ Ball runner block BSHP Resist NR II, SKS
- ▶ Size 30
- ▶ Preload class C1
- ▶ Accuracy class H
- ▶ With standard seal, without ball chain

Material number: R2010 713 04

Preload classes

- C0 = Without preload (clearance)
- C1 = Moderate preload
- C2 = Average preload

Key

- gray numbers = no preferred variant / combination (partially longer delivery times)

Seals

- SS = Standard seal
- LS = Low-friction seal
- DS = Double-lip seal

Size	Ball runner block with size	Preload class			Accuracy class			Seal on ball runner block						Mass (kg) m	Load capacities ²⁾ (N)		Load moments ²⁾ (Nm)			
		C0	C1	C2	N	H	P	without ball chain			with ball chain				C	C ₀	→ ↕ ←		↶ ↷	
								SS	LS ¹⁾	DS	SS	LS ¹⁾	DS				M _t	M _{t0}	M _L	M _{L0}
SNS																				
15	R2011 1	9			4	3	-	04	05	-	06	07	-	0.15	5100	9300	63	90	34	49
			1		4	3	2	04	05	0X	06	07	0W							
				2	-	3	2	04	-	0X	06	-	0W							
20	R2011 8	9			4	3	-	04	05	-	06	07	-	0.35	12300	16900	205	215	110	115
			1		4	3	2	04	05	0X	06	07	0W							
				2	-	3	2	04	-	0X	06	-	0W							
25	R2011 2	9			4	3	-	04	05	-	06	07	-	0.50	15000	21000	270	295	150	165
			1		4	3	2	04	05	0X	06	07	0W							
				2	-	3	2	04	-	0X	06	-	0W							
30	R2011 7	9			4	3	-	04	05	-	06	07	-	0.85	20800	28700	460	500	245	265
			1		4	3	2	04	05	0X	06	07	0W							
				2	-	3	2	04	-	0X	06	-	0W							
35	R2011 3	9			4	3	-	04	05	-	06	07	-	1.25	27600	37500	760	805	375	390
			1		4	3	2	04	05	0X	06	07	0W							
				2	-	3	2	04	-	0X	06	-	0W							
SLS																				
15	R2012 1	9			4	3	-	04	05	-	06	07	-	0.20	8500	14000	82	132	64	104
			1		4	3	2	04	05	0X	06	07	0W							
				2	-	3	2	04	-	0X	06	-	0W							
20	R2012 8	9			4	3	-	04	05	-	06	07	-	0.45	16000	24400	265	310	190	230
			1		4	3	2	04	05	0X	06	07	0W							
				2	-	3	2	04	-	0X	06	-	0W							
25	R2012 2	9			4	3	-	04	05	-	06	07	-	0.65	20000	31600	365	450	290	350
			1		4	3	2	04	05	0X	06	07	0W							
				2	-	3	2	04	-	0X	06	-	0W							
30	R2012 7	9			4	3	-	04	05	-	06	07	-	1.10	26300	40100	590	695	420	495
			1		4	3	2	04	05	0X	06	07	0W							
				2	-	3	2	04	-	0X	06	-	0W							
35	R2012 3	9			4	3	-	04	05	-	06	07	-	1.70	36500	56200	1,025	1210	710	840
			1		4	3	2	04	05	0X	06	07	0W							
				2	-	3	2	04	-	0X	06	-	0W							
SKS																				
15	R2010 1	9			4	3	-	04	05	-	06	07	-	0.10	4500	5600	44	55	16	19
			1		4	3	-	04	05	0X	06	07	0W							
				-	-	-	-	-	-	-	-	-	-							
20	R2010 8	9			4	3	-	04	05	-	06	07	-	0.25	8200	9400	125	115	45	40
			1		4	3	-	04	05	0X	06	07	0W							
				-	-	-	-	-	-	-	-	-	-							
25	R2010 2	9			4	3	-	04	05	-	06	07	-	0.35	10500	12600	195	180	70	65
			1		4	3	-	04	05	0X	06	07	0W							
				-	-	-	-	-	-	-	-	-	-							
30	R2010 7	9			4	3	-	04	05	-	06	07	-	0.60	14500	17200	320	295	110	105
			1		4	3	-	04	05	0X	06	07	0W							
				-	-	-	-	-	-	-	-	-	-							
35	R2010 3	9			4	3	-	04	05	-	06	07	-	0.90	19300	22400	545	485	170	150
			1		4	3	-	04	05	0X	06	07	0W							
				-	-	-	-	-	-	-	-	-	-							
E.g.:	R2010 7	1			3			04												

- 1) Only for accuracy classes N and H
 2) Load capacities and load moments for ball runner block **without** ball chain. Load capacities and load moments for ball runner block **with** ball chain 14
 Determination of the dynamic load capacities and load moments is based on a stroke travel of 100,000 m according to DIN ISO 14728-1. Often only 50,000 m are actually stipulated. For comparison: Multiply the values **C**, **M_t** and **M_L** by 1.26 according to the table.

Note

Dimensions, dimension drawing see standard ball runner block BSHP

Product description

General notes on the ball runner blocks Resist CR

- ▶ For material numbers, please refer to the following pages.
- ▶ Dimensions, dimension drawing, dynamic characteristics, load capacities, rigidity and moments see corresponding standard ball runner blocks made of steel
- ▶ Steel ball runner block body with corrosion-resistant coating, matte-silver finish, hard chrome plated.
- ▶ Pre-lubricated

For ball runner blocks and ball guide rails Resist CR, matte-silver, hard chrome plated, deviating tolerances of the dimensions H and A₃ are to be observed (see "Accuracy classes and their tolerances").

Recommended ball runner blocks for ball guide rails Resist CR of accuracy class H and preload class C0 and C1

Recommended ball runner blocks, size 15 – 65

- ▶ Accuracy class H
- ▶ Preload class C0

Recommended ball runner blocks, size 30 – 65

- ▶ Accuracy class H
- ▶ Preload class C1

Definition of the format of ball runner blocks

Criterion	Designation	Code (example)		
		F	N	S
Width	Flange (F)	F		
	Slimline (S)	S		
	Wide (B)	B		
	Compact (C)	C		
Length	Normal (N)		N	
	Long (L)		L	
	Short (K)		K	
Height	Standard height (S)			S
	High (H)			H
	Low (N)			N



Ball chain (optional)

- ▶ Optimized noise level

Overview of formats

Standard ball runner blocks¹⁾ BSHP up to size 45

FNS

R1651 ... 7.

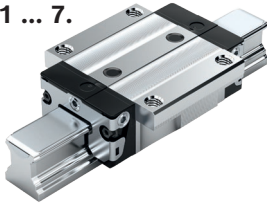

FLS

R1653 ... 7.



SNS

R1622 ... 7.

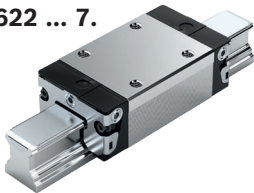

SLS

R1623 ... 7.



SNH

R1621 ... 7.

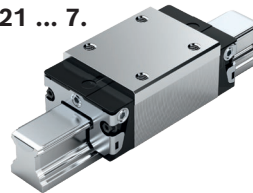

SLH

R1624 ... 7.

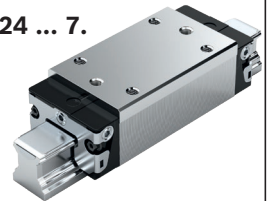

FNN

R1693 ... 6.²⁾



FKN

R1663 ... 6.²⁾



SNN

R1694 ... 6.²⁾



SKN

R1664 ... 6.²⁾



Heavy-duty ball runner blocks²⁾ BSHP from size 55

FNS

R1651 ... 6.

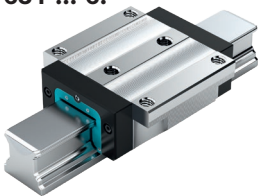

FLS

R1653 ... 6.



SNS

R1622 ... 6.

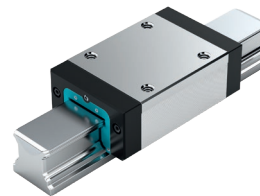

SLS

R1623 ... 6.



SNH

R1621 ... 6.

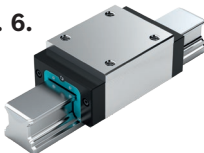

SLH

R1624 ... 6.



Super ball runner blocks²⁾

FKS

R1661 ... 7.

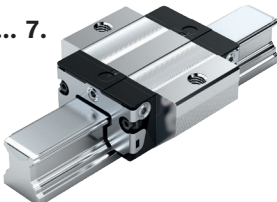

SKS

R1662 ... 7.

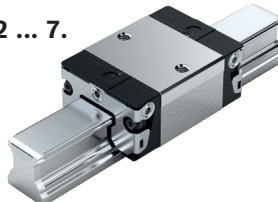

- 1) With ball chain
- 2) Without ball chain

FNS, FLS, SNS, SLS, SNH, SLH, FNN, FKN, SNN, SKN, FKS, SKS

Standard ball runner blocks BSHP

Format	Size	Ball runner block with size	Preload class		Accuracy class	Seal on ball runner block					
			C0	C1		without ball chain			with ball chain		
					H	SS	LS	DS	SS	LS	DS
FNS	45	R1651 4	9	1	3	70	-	-	72	-	-
					3	70	-	7Z	72	-	7Y
E.g.:		R1651 4		1	3	70					
FLS	45	R1653 4	9	1	3	70	-	-	72	-	-
					3	70	-	7Z	72	-	7Y
SNS	45	R1622 4	9	1	3	70	-	-	72	-	-
					3	70	-	7Z	72	-	7Y
SLS	45	R1623 4	9	1	3	70	-	-	72	-	-
					3	70	-	7Z	72	-	7Y
SNH	15	R1621 1	9	-	3	70	71	-	72	73	-
	25	R1621 2	9	-	3	70	71	-	72	73	-
	30	R1621 7	9	1	3	70	71	-	72	73	-
					3	70	71	7Z	72	73	7Y
	35	R1621 3	9	1	3	70	71	-	72	73	-
	45	R1621 4	9	1	3	70	71	7Z	72	73	7Y
3					70	-	-	72	-	-	
SLH	25	R1624 2	9	-	3	70	71	-	72	73	-
	30	R1624 7	9	1	3	70	71	-	72	73	-
					3	70	71	7Z	72	73	7Y
	35	R1624 3	9	1	3	70	71	-	72	73	-
					3	70	71	7Z	72	73	7Y
	45	R1624 4	9	1	3	70	-	-	72	-	-
3					70	-	7Z	72	-	7Y	
FNN	20	R1693 8	9	-	3	60	-	-	-	-	-
	25	R1693 2	9	-	3	60	-	-	-	-	-
FKN	20	R1663 8	9	-	3	60	-	-	-	-	-
	25	R1663 2	9	-	3	60	-	-	-	-	-
SNN	20	R1694 8	9	-	3	60	-	-	-	-	-
	25	R1694 2	9	-	3	60	-	-	-	-	-
SKN	20	R1664 8	9	-	3	60	-	-	-	-	-
	25	R1664 2	9	-	3	60	-	-	-	-	-

Ordering example

Options:

- ▶ Ball runner block BSHP Resist CR, FNS
- ▶ Size 45
- ▶ Preload class C1
- ▶ Accuracy class H
- ▶ With standard seal, without ball chain

Material number: R1651 413 70

Preload classes

C0 = Without preload (clearance)
C1 = Moderate preload

Seals

SS = Standard seal
LS = Low-friction seal
DS = Double-lip seal

Key

gray numbers
= no preferred variant / combination
(partially longer delivery times)

Heavy-duty ball runner blocks BSHP

Format	Size	Ball runner block with size	Preload class		Accuracy class	Seal on ball runner block without ball chain	
			C0	C1		H	SS
FNS	55	R1651 5	9	1	3	60	
	65	R1651 6	9	1	3	60	
FLS	55	R1653 5	9	1	3	60	
	65	R1653 6	9	1	3	60	
SNS	55	R1622 5	9	1	3	60	
	65	R1622 6	9	1	3	60	
SLS	55	R1623 5	9	1	3	60	
	65	R1623 6	9	1	3	60	
SNH	55	R1621 5	9	1	3	60	
SLH	55	R1624 5	9	1	3	60	

Super ball runner blocks

Format	Size	Ball runner block with size	Preload class		Accuracy class	Seal on ball runner block without ball chain				
			C0	C1		H	SS	LS	DS	
FKS	15	R1661 1	9	-	3	70	71	-		
	20	R1661 8	9	-	3	70	71	-		
	25	R1661 2	9	-	3	70	71	-		
	30	R1661 7		9		3	70	71	-	
						1	3	70	71	7Z
35	R1661 3		9		3	70	71	-		
					1	3	70	71	7Z	
SKS	15	R1662 1	9	-	3	70	71	-		
	20	R1662 8	9	-	3	70	71	-		
	25	R1662 2	9	-	3	70	71	-		
	30	R1662 7		9		3	70	71	-	
						1	3	70	71	7Z
35	R1662 3		9		3	70	71	-		
					1	3	70	71	7Z	

Note

Dimensions, dimension drawing, load capacities, rigidity and moments see standard/heavy-duty ball runner block BSHP and super ball runner block.

Product description

Characteristic features

- ▶ Maximum rigidity in all directions of loading
- ▶ High torque load capacity

Proven cover strip for the ball guide rail fastening bores

- ▶ **One** cover for all bore holes saves time and costs
- ▶ Made of corrosion-resistant spring steel as per DIN EN 10088
- ▶ Easy and safe during mounting
- ▶ Clip and secure

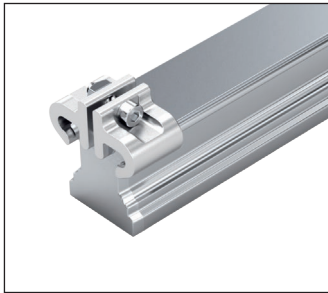
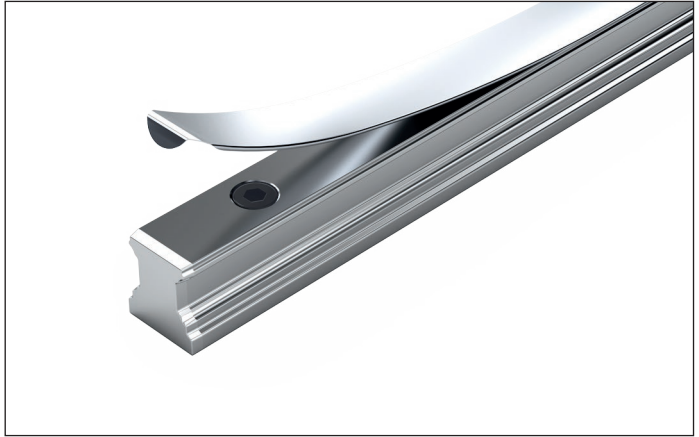

Ball guide rails with cover strip and strip clamps made of aluminum

- ▶ Without end-face threaded holes (not required)

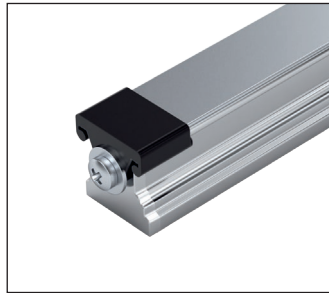

Ball guide rails with cover strip and bolted plastic protective caps

- ▶ With threaded holes at the end faces



Ball guide rails with plastic caps

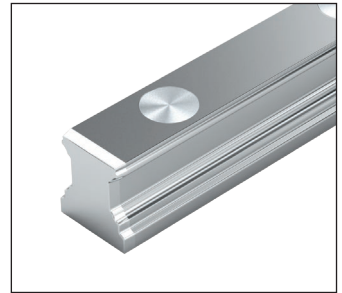

Ball guide rails with steel caps

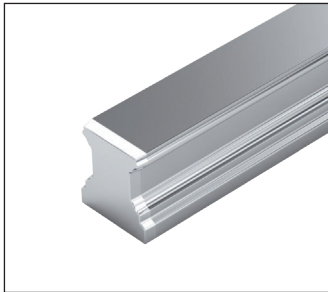

Ball guide rails for bolting from below

Definition of the format of ball guide rails

Criterion	Designation	Code (example)		
		S	N	S
Width	Slimline (S)	S		
	Wide (B)	B		
Length	Normal (N)		N	
Height	Standard height (S)			S
	Without groove (O)			O

Ordering guide rails in the recommended rail lengths

Ordering ball guide rails in the recommended rail lengths

The procedure shown in the following ordering examples applies to all ball guide rails. Recommended rail lengths are more cost effective.

Options and material numbers										
Size	Ball guide rail with size	Accuracy class					Number of partial sections, Rail length L (mm), ...		Spacing T (mm)	Recommended rail length in accordance with formula $L = n_B \cdot T - 4$
		N	H	P	SP	UP	One-piece	Composite		
15	R1605 13	4	3	2	1	9	31, ...	3, ...	60	64
20	R1605 83	4	3	2	1	9	31, ...	3, ...	60	64
25	R1605 23	4	3	2	1	9	31, ...	3, ...	60	64
30	R1605 73	4	3	2	1	9	31, ...	3, ...	80	48
35	R1605 33	4	3	2	1	9	61, ...	6, ...	80	48
45	R1605 43	4	3	2	1	9	61, ...	6, ...	105	36
55	R1605 53	4	3	2	1	9	61, ...	6, ...	120	32
65	R1605 63	4	3	2	1	9	61, ...	6, ...	150	25
E.g.:	R1605 73	3					31, 1676			

Excerpt from table with material numbers and recommended rail lengths for ordering example

From the desired rail length to the recommended length

$$L = \left(\frac{L_W}{T} \right)^* \cdot T - 4$$

* Round up quotient L_W/T to the nearest whole number!

Calculation example

$$L = \left(\frac{1660}{80 \text{ mm}} \right) \cdot 80 \text{ mm} - 4 \text{ mm}$$

$$L = 21 \cdot 80 \text{ mm} - 4 \text{ mm}$$

$$L = 1676 \text{ mm}$$

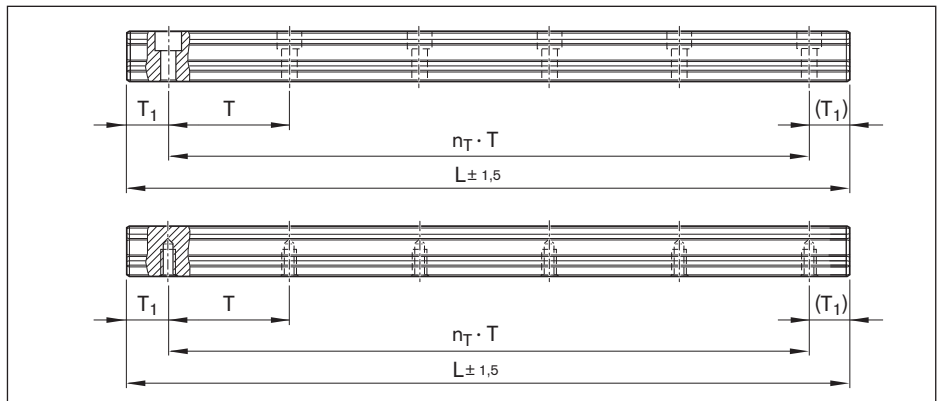

Basis: Number of holes

$$L = n_B \cdot T - 4 \text{ mm}$$

Basis: Number of spaces

$$L = n_T \cdot T + 2 \cdot T_{1S}$$

L = Recommended rail length (mm)

L_W = Desired rail length (mm)

T = Spacing (mm)

T_{1S} = Preferred dimension (mm)

n_B = Number of holes (-)

n_T = Number of spaces (-)

Notes on ordering examples

If preferred dimension T_{1S} is not used, it is possible to choose between:

- ▶ Select end spacing T_1 between T_{1S} and $T_{1 \min}$
- ▶ As an alternative, it is possible to choose end spacings T_1 to $T_{1 \max}$.

Ordering example 1 (to L_{\max})

- ▶ Ball guide rail SNS size 30 with cover strip and strip clamps
- ▶ Accuracy class H
- ▶ Calculated rail length 1676 mm, (20 · T, preferred dimension $T_{1S} = 38$ mm; number of holes $n_B = 21$)

Ordering data

Material number, rail length (mm)

$T_1 / n_T \cdot T / T_1$ (mm)

R1605 733 31, 1676 mm

38 / 20 · 80 / 38 mm

Ordering example 2 (above L_{\max})

- ▶ Ball guide rail SNS size 30 with cover strip and strip clamps
- ▶ Accuracy class H
- ▶ Calculated rail length 5116 mm, 2 partial sections (63 · T, preferred dimension $T_{1S} = 38$ mm; number of holes $n_B = 64$)

Ordering data

Material number with number of partial sections, rail length (mm)

$T_1 / n_T \cdot T / T_1$ (mm)

R1605 733 32, 5116 mm

38 / 63 · 80 / 38 mm

In the case of rail lengths above L_{\max} , partial sections approved by Rexroth are joined together.

SNS/SNO with cover strip and strip clamps



R1605 .3. ../ R1605 .B. ..

For bolting from above, with cover strip made of corrosion-resistant spring steel per EN 10088 and strip clamps made of aluminum (without end-face thread bore hole)

Notes

- ▶ Secure the cover strip!
- ▶ Strip clamps included in scope of delivery.
- ▶ Observe the instruction for mounting!
Please request the "Mounting instructions for ball rail systems" and "Mounting instructions for cover strip".
- ▶ Composite ball guide rail also available.

Further ball guide rails SNS/SNO and accessories available.

- ▶ Cover strip, protective caps (see Accessories for ball guide rails)

**Ball guide rails SNO R1605 .B. .. with smooth base area for mounting surfaces from cast mineral parts
In size 25-45 and available in accuracy class P and SP.**

Options and material numbers

Size	Ball guide rail with size	Accuracy class					Number of partial sections, rail length L (mm),		Spacing T (mm)	Recommended rail length in accordance with formula $L = n_B \cdot T - 4 \text{ mm}$	
		N	H	P	SP	UP	One-piece	Composite		Maximum number of holes n_B	
15	R1605 13	4	3	2	1	9	31,	3.,	60	64	
20	R1605 83	4	3	2	1	9	31,	3.,	60	64	
25	R1605 23	4	3	2	1	9	31,	3.,	60	64	
30	R1605 73	4	3	2	1	9	31,	3.,	80	48	
35	R1605 33	4	3	2	1	9	61,	6.,	80	48	
45	R1605 43	4	3	2	1	9	61,	6.,	105	36	
55	R1605 53	4	3	2	1	9	61,	6.,	120	32	
65	R1605 63	4	3	2	1	9	61,	6.,	150	25	
E.g.:	R1605 73	3					31, 1676				

Ordering example 1 (to L_{max})

Options:

- ▶ Ball guide rail SNS
- ▶ Size 30
- ▶ Accuracy class H
- ▶ One-piece
- ▶ Rail length L = 1676 mm

Material number:

R1605 733 31, 1676 mm

Ordering example 2 (above L_{max})

Options:

- ▶ Ball guide rail SNS
- ▶ Size 30
- ▶ Accuracy class H
- ▶ **2 partial sections**
- ▶ Rail length L = 5116 mm

Material number:

R1605 733 **32**, 5116 mm

Ordering example 3

(up to L_{max} , with smooth surface)

Options:

- ▶ Ball guide rail SNO
- ▶ Size 30
- ▶ Accuracy class H
- ▶ One-piece
- ▶ Rail length L = 1676 mm

Material number:

R1605 **7B3** 31, 1676 mm

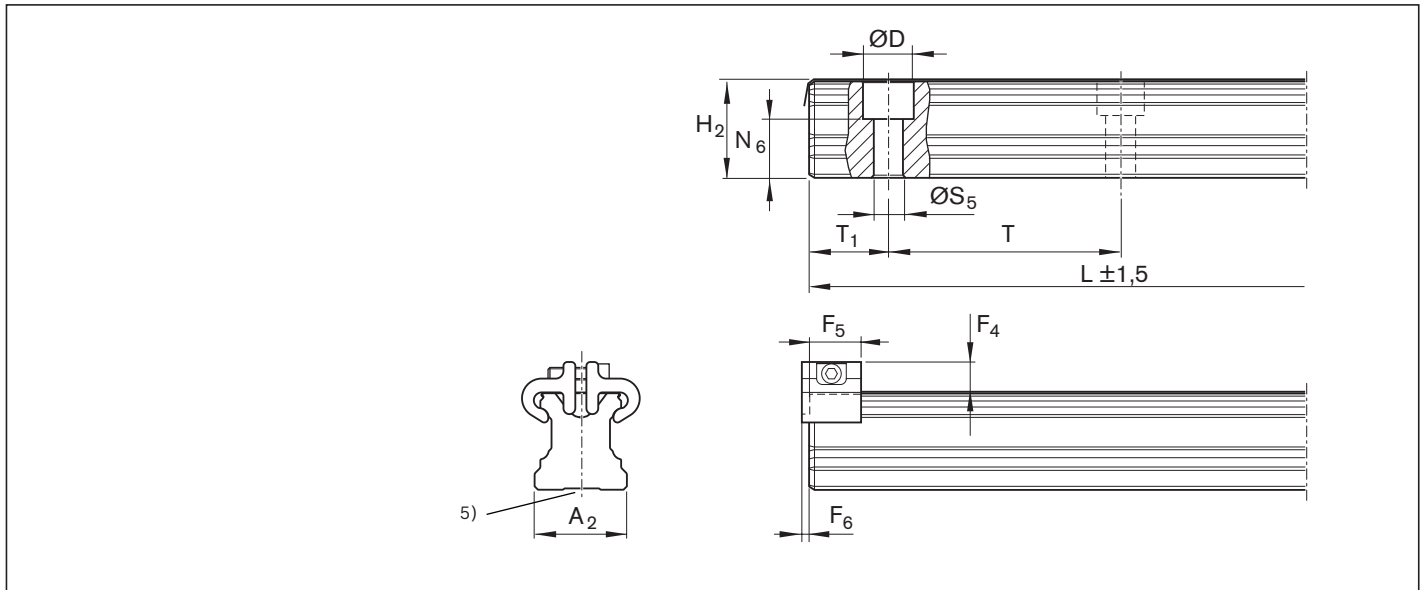

Size	Dimensions (mm)														Mass m (kg/m)
	A ₂	D	F ₄ ³⁾	F ₅	F ₆	H ₂ ¹⁾	L _{max} ²⁾	N ₆ ^{±0.5}	S ₅	T	T _{1 min}	T _{1S} ⁴⁾	T _{1 max}		
15	15	7.4	7.3	12	2.0	16.30	3836	10.3	4.5	60	12	28.0	50	1.4	
20	20	9.4	7.1	12	2.0	20.75	3836	13.2	6.0	60	13	28.0	50	2.4	
25	23	11.0	8.2	13	2.0	24.45	3836	15.2	7.0	60	13	28.0	50	3.2	
30	28	15.0	8.7	13	2.0	28.55	3836	17.0	9.0	80	16	38.0	68	5.0	
35	34	15.0	11.7	16	2.2	32.15	3836	20.5	9.0	80	16	38.0	68	6.8	
45	45	20.0	12.5	18	2.2	40.15	3776	23.5	14.0	105	18	50.5	89	10.5	
55	53	24.0	14.0	17	3.2	48.15	3836	29.0	16.0	120	20	58.0	102	16.2	
65	63	26.0	15.0	17	3.2	60.15	3746	38.5	18.0	150	21	73.0	130	22.4	

- 1) Dimension H₂ with cover strip
 Size 15 with cover strip 0.1 mm
 Size 20 - 30 with cover strip 0.2 mm
 Size 35 - 65 with cover strip 0.3 mm
- 2) For size 20 - 45 in accuracy class N, H and P one-pieceball guide rail lengths are available for
 Size 20 - 25 to 5816 mm available on request.
 Size 30 - 35 to 5836 mm available on request.
 Size 45 to 5771 mm available on request.
- 3) Dimension H₄ with cover strip
- 4) Preferred dimension T_{1S} with tolerances ± 0.75 recommended.
- 5) Ball guide rails SNO with smooth base surface (without base groove).

SNS/SNO with cover strip and protective caps



R1605 .6. .. / R1605 .D. ..

For bolting from above, with cover strip made of corrosion-resistant spring steel per EN 10088 and screw-down plastic protective caps (with end-face thread bore hole)

Notes

- ▶ Secure the cover strip!
- ▶ Protective caps with screws and washers are included in the scope of delivery.
- ▶ Observe the instruction for mounting!
Please request the "Mounting instructions for ball rail systems" and "Mounting instructions for cover strip".
- ▶ Composite ball guide rail also available.

Further ball guide rails SNS/SNO and accessories

- ▶ Cover strip, protective caps (see Accessories for ball guide rails)

Ball guide rails SNO R1605 .D. .. with smooth base area for mounting surfaces from cast mineral parts
In size 25-45 and available in accuracy class P and SP.

Options and material numbers

Size	Ball guide rail with size	Accuracy class					Number of partial sections, rail length L (mm), ...		Spacing T (mm)	Recommended rail length in accordance with formula $L = n_B \cdot T - 4 \text{ mm}$		
		N	H	P	SP	UP	One-piece	Composite		Maximum number of holes n_B		
15	R1605 16	4	3	2	1	9	31, ...	3., ...	60	64		
20	R1605 86	4	3	2	1	9	31, ...	3., ...	60	64		
25	R1605 26	4	3	2	1	9	31, ...	3., ...	60	64		
30	R1605 76	4	3	2	1	9	31, ...	3., ...	80	48		
35	R1605 36	4	3	2	1	9	61, ...	6., ...	80	48		
45	R1605 46	4	3	2	1	9	61, ...	6., ...	105	36		
55	R1605 56	4	3	2	1	9	61, ...	6., ...	120	32		
65	R1605 66	4	3	2	1	9	61, ...	6., ...	150	25		
E.g.:	R1605 76	3					31, 1676					

Ordering example 1 (to L_{max})

Options:

- ▶ Ball guide rail SNS
- ▶ Size 30
- ▶ Accuracy class H
- ▶ One-piece
- ▶ Rail length L = 1676 mm

Material number:

R1605 763 31, 1676 mm

Ordering example 2 (above L_{max})

Options:

- ▶ Ball guide rail SNS
- ▶ Size 30
- ▶ Accuracy class H
- ▶ **2 partial sections**
- ▶ Rail length L = 5116 mm

Material number:

R1605 763 32, 5116 mm

Ordering example 3 (up to L_{max} , with smooth surface)

Options:

- ▶ Ball guide rail SNO
- ▶ Size 30
- ▶ Accuracy class H
- ▶ One-piece
- ▶ Rail length L = 1676 mm

Material number:

R1605 7D3 31, 1676 mm

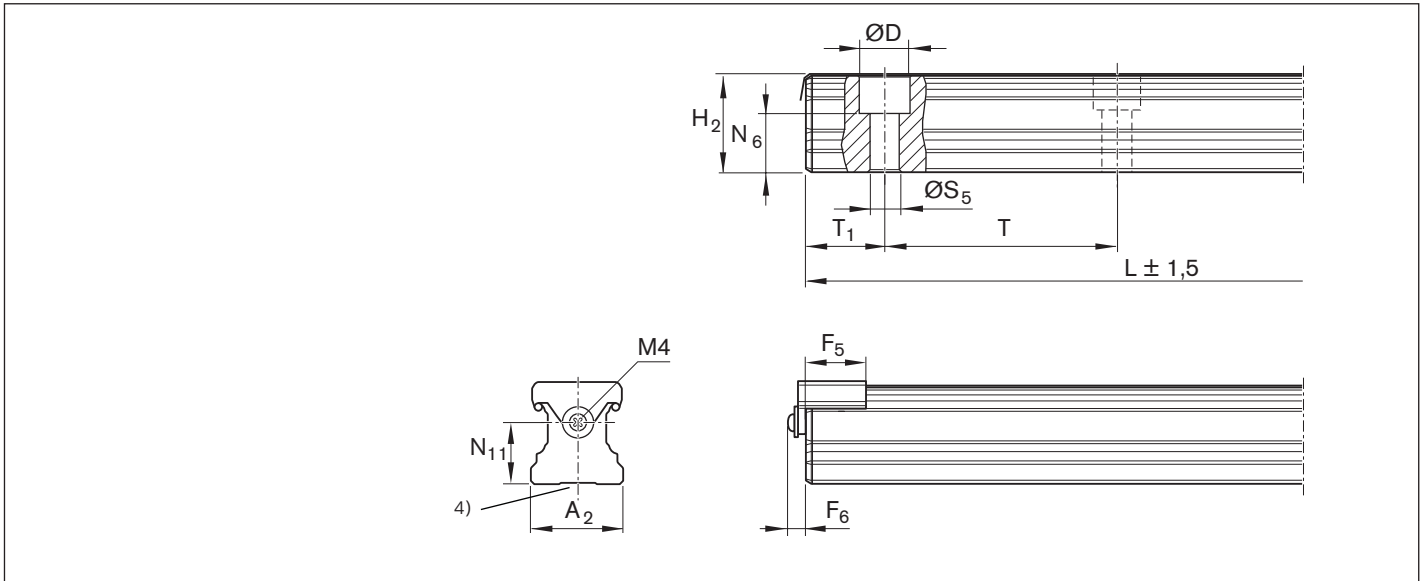

Size	Dimensions (mm)														Mass m (kg/m)
	A ₂	D	F ₅	F ₆	H ₂ ¹⁾	L _{max} ²⁾	N ₆ ^{±0.5}	N ₁₁	S ₅	T	T _{1 min} ³⁾	T _{1S} ⁵⁾	T _{1 max}		
15	15	7.4	14.0	6.5	16.30	3836	10.3	9.8	4.5	60	12	28.0	50	1.4	
20	20	9.4	14.0	6.5	20.75	3836	13.2	13.0	6.0	60	13	28.0	50	2.4	
25	23	11.0	15.2	6.5	24.45	3836	15.2	15.0	7.0	60	13	28.0	50	3.2	
30	28	15.0	15.2	7.0	28.55	3836	17.0	18.0	9.0	80	16	38.0	68	5.0	
35	34	15.0	18.0	7.0	32.15	3836	20.5	22.0	9.0	80	16	38.0	68	6.8	
45	45	20.0	20.0	7.0	40.15	3776	23.5	30.0	14.0	105	18	50.5	89	10.5	
55	53	24.0	20.0	7.0	48.15	3836	29.0	30.0	16.0	120	20	58.0	102	16.2	
65	63	26.0	20.0	7.0	60.15	3746	38.5	40.0	18.0	150	21	73.0	130	22.4	

- 1) Dimension H₂ with cover strip
 Size 15 with cover strip 0.1 mm
 Size 20 - 30 with cover strip 0.2 mm
 Size 35 - 65 with cover strip 0.3 mm
- 2) For size 20 - 45 in accuracy class N, H and P one-pieceball guide rail lengths are available for
 Size 20 - 25 to 5816 mm available on request.
 Size 30 - 35 to 5836 mm available on request.
 Size 45 to 5771 mm available on request.
- 3) For end spaces below T_{1 min}, no threaded holes in end faces possible. Secure the cover strip.
- 4) Ball guide rails SNO with smooth base surface (without base groove).
- 5) Preferred dimension T_{1S} with tolerances ± 0.75 recommended.

SNS/SNO with plastic caps



R1605 .0. .. / R1605 .C. ..

For bolting from above with plastic caps

Notes

- ▶ Plastic caps included in scope of supply.
- ▶ Observe the instruction for mounting!
Please request the "Mounting instructions for ball rail systems."
- ▶ Composite ball guide rail also available.

Further ball guide rails SNS and accessories

- ▶ Corrosion-resistant ball guide rails Resist NR, Resist CR
- ▶ Caps made of plastic see Accessories for ball guide rails

Ball guide rails SNO R1605 .C. .. with smooth base area for mounting surfaces from cast mineral parts

In sizes 25-45 and available in accuracy class P and SP.

Options and material numbers

Size	Ball guide rail with size	Accuracy class					Number of partial sections, rail length L (mm), ...		Spacing T (mm)	Recommended rail length in accordance with formula $L = n_B \cdot T - 4 \text{ mm}$	
		N	H	P	SP	UP	One-piece	Composite			Maximum number of holes n_B
15	R1605 10	4	3	2	1	9	31, ...	3, ...	60	64	
20	R1605 80	4	3	2	1	9	31, ...	3, ...	60	64	
25	R1605 20	4	3	2	1	9	31, ...	3, ...	60	64	
30	R1605 70	4	3	2	1	9	31, ...	3, ...	80	48	
35	R1605 30	4	3	2	1	9	31, ...	3, ...	80	48	
45	R1605 40	4	3	2	1	9	31, ...	3, ...	105	36	
55	R1605 50	4	3	2	1	9	31, ...	3, ...	120	32	
65	R1605 60	4	3	2	1	9	31, ...	3, ...	150	25	
E.g.:	R1605 70	3					31, 1676				

Ordering example 1 (to L_{max})

Options:

- ▶ Ball guide rail SNS
- ▶ Size 30
- ▶ Accuracy class H
- ▶ One-piece
- ▶ Rail length L = 1676 mm

Material number:

R1605 703 31, 1676 mm

Ordering example 2 (above L_{max})

Options:

- ▶ Ball guide rail SNS
- ▶ Size 30
- ▶ Accuracy class H
- ▶ **2 partial sections**
- ▶ Rail length L = 5116 mm

Material number:

R1605 703 32, 5116 mm

Ordering example 3 (up to L_{max} , with smooth surface)

Options:

- ▶ Ball guide rail SNO
- ▶ Size 30
- ▶ Accuracy class H
- ▶ One-piece
- ▶ Rail length L = 1676 mm

Material number:

R1605 7C3 31, 1676 mm

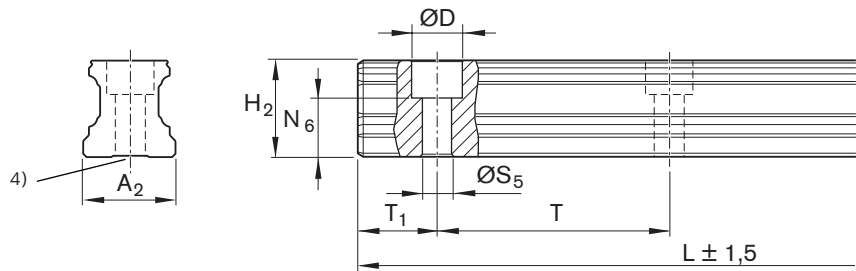

Size	Dimensions (mm)										Mass m (kg/m)
	A ₂	D	H ₂ ¹⁾	L _{max} ²⁾	N ₆ ^{±0.5}	S ₅	T	T _{1 min}	T _{1S} ³⁾	T _{1 max}	
15	15	7.4	16.20	3836	10.3	4.5	60	10	28.0	50	1.4
20	20	9.4	20.55	3836	13.2	6.0	60	10	28.0	50	2.4
25	23	11.0	24.25	3836	15.2	7.0	60	10	28.0	50	3.2
30	28	15.0	28.35	3836	17.0	9.0	80	12	38.0	68	5.0
35	34	15.0	31.85	3836	20.5	9.0	80	12	38.0	68	6.8
45	45	20.0	39.85	3776	23.5	14.0	105	16	50.5	89	10.5
55	53	24.0	47.85	3836	29.0	16.0	120	18	58.0	102	16.2
65	63	26.0	59.85	3746	38.5	18.0	150	20	73.0	130	22.4

- 1) Dimension H₂ without cover strip
- 2) For size 20 - 45 in accuracy class N, H and P one-pieceball guide rail lengths are available for
 Size 20 - 25 to 5816 mm available on request.
 Size 30 - 35 to 5836 mm available on request.
 Size 45 to 5771 mm available on request.
- 3) Preferred dimension T_{1S} with tolerances ± 0.75 recommended.
- 4) Ball guide rails SNO with smooth base surface (without base groove).

SNS with caps made of steel

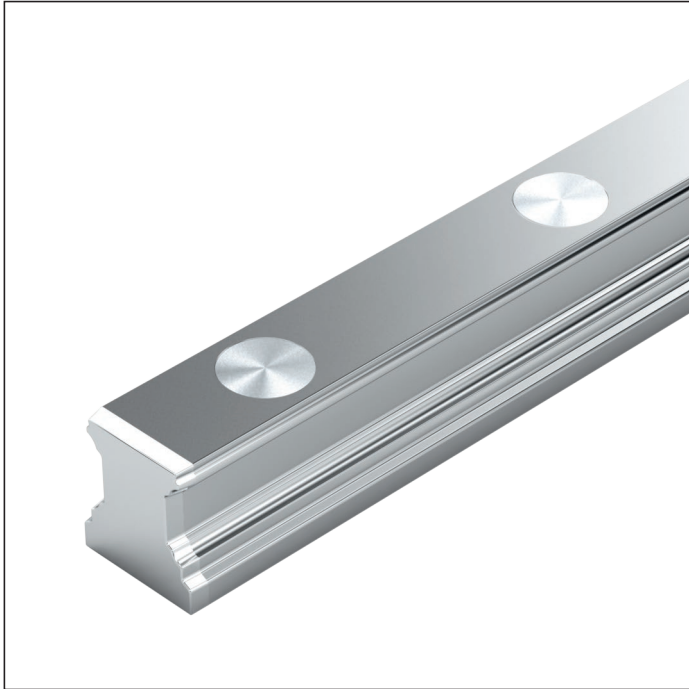

R1606 .5. ..

**For bolting from above,
for caps made of steel**

Notes

- ▶ Caps made of steel not included in scope of delivery.
- ▶ Observe the instruction for mounting!
Please request the "Mounting instructions for ball rail systems."

- ▶ Composite ball guide rail also available.

Further ball guide rails SNS and accessories

- ▶ Caps made of steel, mounting device for caps made of steel see Accessories for ball guide rails

Options and material numbers

Size	Ball guide rail with size	Accuracy class				Number of partial sections, rail length L (mm), ...		Spacing T (mm)	Recommended rail length in accordance with formula $L = n_B \cdot T - 4 \text{ mm}$	
		N	H	P	SP	One-piece	Composite		Maximum number of holes n_B	
25	R1606 25	4	3	2	1	31, ...	3, ...	60	64	
30	R1606 75	4	3	2	1	31, ...	3, ...	80	48	
35	R1606 35	4	3	2	1	31, ...	3, ...	80	48	
45	R1606 45	4	3	2	1	31, ...	3, ...	105	36	
55	R1606 55	4	3	2	1	31, ...	3, ...	120	32	
65	R1606 65	4	3	2	1	31, ...	3, ...	150	25	
E.g.:	R1606 75	3				31, 1676				

**Ordering example 1
(to L_{max})**

Options:

- ▶ Ball guide rail SNS
- ▶ Size 30
- ▶ Accuracy class H
- ▶ One-piece
- ▶ Rail length L = 1676 mm

Material number:

R1606 753 31, 1676 mm

**Ordering example 2
(above L_{max})**

Options:

- ▶ Ball guide rail SNS
- ▶ Size 30
- ▶ Accuracy class H
- ▶ **2 partial sections**
- ▶ Rail length L = 5116 mm

Material number:

R1606 753 32, 5116 mm

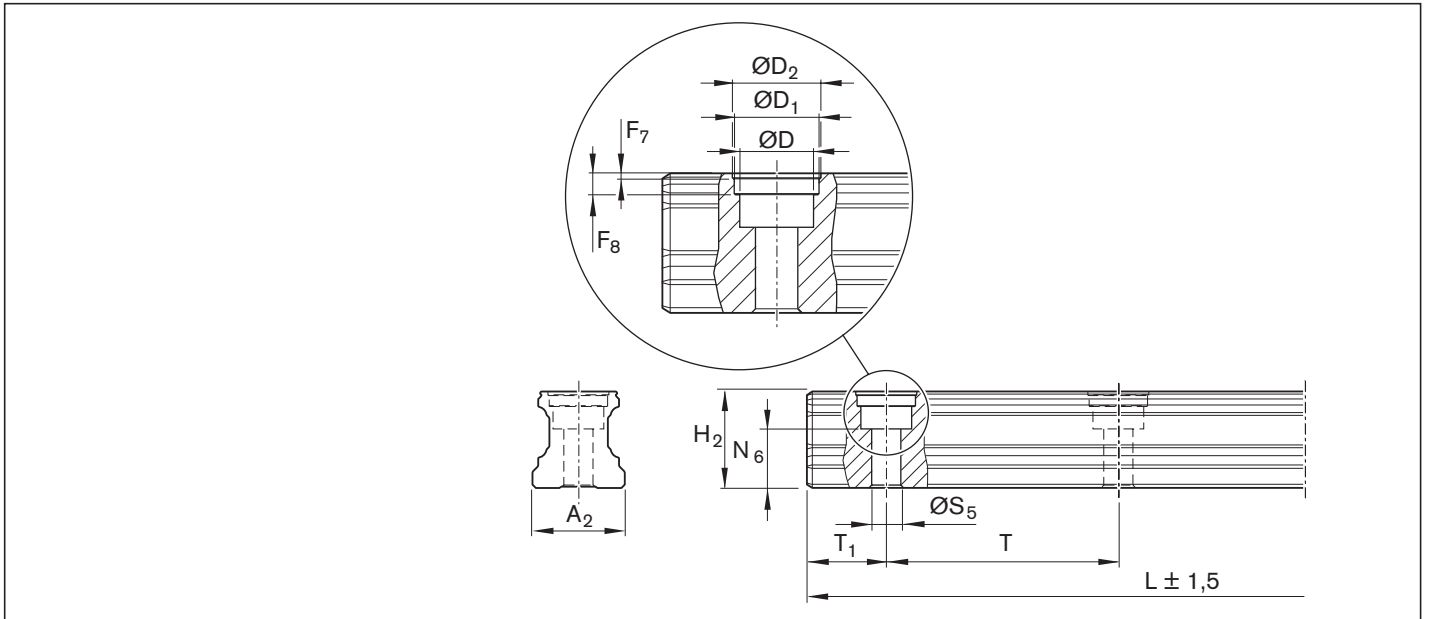

Size	Dimensions (mm)															Mass m (kg/m)
	A ₂	D	D ₁	D ₂	F ₇	F ₈	H ₂ ¹⁾	L _{max} ²⁾	N ₆ ^{±0.5}	S ₅	T	T _{1 min}	T _{1s} ³⁾	T _{1 max}		
25	23	11.0	12.55	13.0	0.90	3.7	24.25	3836	15.2	7.0	60	13	28.0	50	3.2	
30	28	15.0	17.55	18.0	0.90	3.6	28.35	3836	17.0	9.0	80	16	38.0	68	5.0	
35	34	15.0	17.55	18.0	0.90	3.6	31.85	3836	20.5	9.0	80	16	38.0	68	6.8	
45	45	20.0	22.55	23.0	1.45	8.0	39.85	3776	23.5	14.0	105	18	50.5	89	10.5	
55	53	24.0	27.55	28.0	1.45	8.0	47.85	3836	29.0	16.0	120	20	58.0	102	16.2	
65	63	26.0	29.55	30.0	1.45	8.0	59.85	3746	38.5	18.0	150	21	73.0	130	22.4	

- 1) Dimension H₂ without cover strip
- 2) For size 25 - 45 in accuracy class N, H and P one-piece ball guide rail lengths are available for size 25 to 5816 mm on request.
Size 30 - 35 to 5836 mm available on request.
Size 45 to 5771 mm available on request.
- 3) Preferred dimension T_{1s} with tolerances ± 0.75 recommended.

SNS for bolting from below

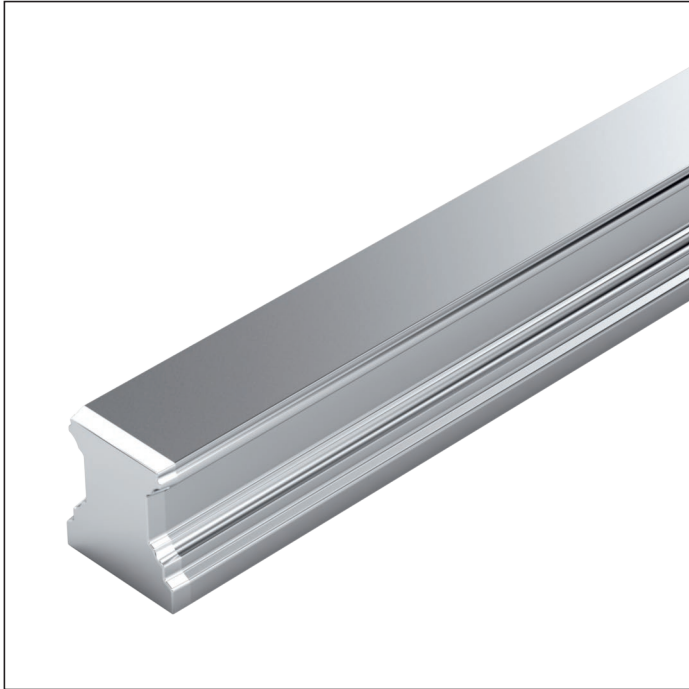

R1607 .0. ..

For bolting from below

Notes

- ▶ Observe the instruction for mounting!
Please request the "Mounting instructions for ball rail systems."
- ▶ Composite ball guide rail also available.

Further ball guide rails SNS and accessories

- ▶ Corrosion-resistant ball guide rails Resist NR, Resist CR

Options and material numbers

Size	Ball guide rail with size	Accuracy class					Number of partial sections, rail length L (mm), ...		Spacing T (mm)	Recommended rail length in accordance with formula $L = n_B \cdot T - 4 \text{ mm}$		
		N	H	P	SP	UP	One-piece	Composite		Maximum number of holes n_B		
15	R1607 10	4	3	2	1	9	31,	3.,	60	64		
20	R1607 80	4	3	2	1	9	31,	3.,	60	64		
25	R1607 20	4	3	2	1	9	31,	3.,	60	64		
30	R1607 70	4	3	2	1	9	31,	3.,	80	48		
35	R1607 30	4	3	2	1	9	31,	3.,	80	48		
45	R1607 40	4	3	2	1	9	31,	3.,	105	36		
55	R1607 50	4	3	2	1	9	31,	3.,	120	32		
65	R1607 60	4	3	2	1	9	31,	3.,	150	25		
E.g.:	R1607 70	3					31, 1676					

**Ordering example 1
(to L_{max})**

Options:

- ▶ Ball guide rail SNS
- ▶ Size 30
- ▶ Accuracy class H
- ▶ One-piece
- ▶ Rail length L = 1676 mm

Material number:

R1607 703 31, 1676 mm

**Ordering example 2
(above L_{max})**

Options:

- ▶ Ball guide rail SNS
- ▶ Size 30
- ▶ Accuracy class H
- ▶ **2 partial sections**
- ▶ Rail length L = 5116 mm

Material number:

R1607 703 32, 5116 mm

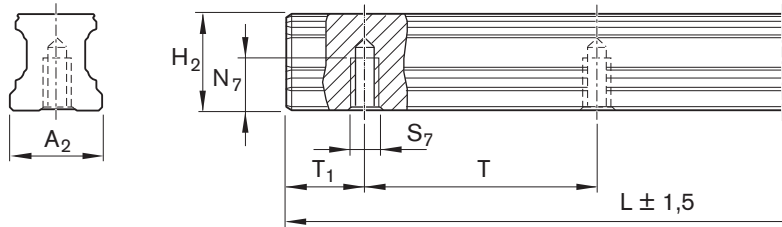

Size	Dimensions (mm)									Mass m (kg/m)
	A ₂	H ₂ ¹⁾	L _{max} ²⁾	N ₇	S ₇	T	T _{1min}	T _{1S} ³⁾	T _{1max}	
15	15	16.20	3836	7.5	M5	60	10	28.0	50	1.4
20	20	20.55	3836	9.0	M6	60	10	28.0	50	2.4
25	23	24.25	3836	12.0	M6	60	10	28.0	50	3.2
30	28	28.35	3836	15.0	M8	80	12	38.0	68	5.0
35	34	31.85	3836	15.0	M8	80	12	38.0	68	6.8
45	45	39.85	3776	19.0	M12	105	16	50.5	89	10.5
55	53	47.85	3836	22.0	M14	120	18	58.0	102	16.2
65	63	59.85	3746	25.0	M16	150	20	73.0	130	22.4

- 1) Dimension H₂ without cover strip
- 2) For size 20 - 45 in accuracy class N, H and P one-pieceball guide rail lengths are available for
 Size 20 - 25 to 5816 mm available on request.
 Size 30 - 35 to 5836 mm available on request.
 Size 45 to 5771 mm available on request.
- 3) Preferred dimension T_{1S} with tolerances ± 0.75 recommended.

Product description

General notes on ball guide rails Resist NR II

For material numbers, please refer to the following pages. For recommended rail lengths, dimensions and gravity, see corresponding standard steel ball guide rails. Observe the chapter "Instruction for mounting"!

Please request the "Mounting instructions for ball rail systems" and "Mounting instructions for cover strip".

Accessories: Cover strip, strip clamps, caps, ... for ball guide rails, see chapter "Accessories for ball guide rails"

Corrosion resistance and conditions of use

Ball guide rails Resist NR II as well as all steel parts are made of corrosion-resistant steel according to DIN EN 10088, strip clamps are made of aluminum. Ball guide rails Resist NR II are used specifically in conjunction with water-based media, heavily diluted acidic materials, alkali or saline solutions. These guides are also ideally suitable for use at relative humidities above 70% and temperatures exceeding 30 °C. Such conditions are found mainly in cleaning plants, electroplating and pickling lines, vapor degreasing plants and refrigeration systems. Since no additional corrosion protection is required, ball rail systems Resist NR II are ideally suited for use in clean rooms and general printed circuit board manufacturing. Other possible areas of application include the pharmaceutical and food industries.

Recommended ball runner blocks for Resist NR II ball guide rails, see the "Ball runner block Resist NR II" chapter
When using ball guide rails NR II, always use the lower load capacities of the ball runner blocks NR II.

Combinations of different accuracy classes

When combining ball guide rail and ball runner block of different accuracy classes, the tolerances for dimensions H and A₃ change (see "Accuracy classes and their tolerances").

Ball guide rails Resist NR II

R2045 .3. ..., SNS can be bolted from above, with cover strip and strip clamps

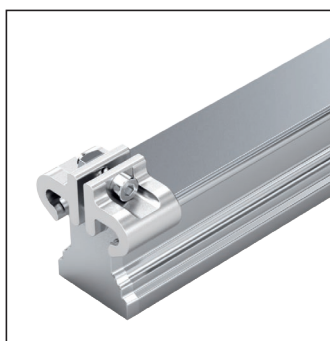

Options and material numbers

Size	Ball guide rail with size	Accuracy class			Number of partial sections, rail length L (mm), ...	
		N	H	P	One-piece	Composite
15 ¹⁾	R2045 13	4	3	2	31, ...	3., ...
20	R2045 83	4	3	2	31, ...	3., ...
25	R2045 23	4	3	2	31, ...	3., ...
30	R2045 73	4	3	2	31, ...	3., ...
35	R2045 33	4	3	2	61, ...	6., ...
E.g.:	R2045 73	3			31, 1676	

1) Maximum rail length 1856 mm, maximum number of holes n_B 30

Instruction for mounting

- ▶ Secure the cover strip!
- ▶ Strip clamps included in scope of delivery.
- ▶ Composite ball guide rail also available.

Ordering example 1 (to L_{max})

- Options:
- ▶ Ball guide rail NR II, SNS
 - ▶ Size 30
 - ▶ Accuracy class H
 - ▶ One-piece
 - ▶ Rail length L = 1676 mm

Material number:
R2045 733 31, 1676 mm

Ordering example 2 (above L_{max})

- Options:
- ▶ Ball guide rail NR II, SNS
 - ▶ Size 30
 - ▶ Accuracy class H
 - ▶ **2 partial sections**
 - ▶ Rail length L = 5116 mm

Material number:
R2045 733 32, 5116 mm

Ball guide rails Resist NR II

R2045 .0. ... , SNS can be bolted from above, with plastic caps

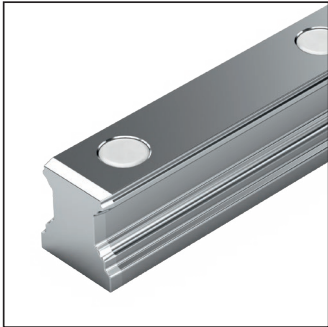

Options and material numbers

Size	Ball guide rail with size	Accuracy class			Number of partial sections, rail length L (mm), ...	
		N	H	P	One-piece	Composite
15 ¹⁾	R2045 10	4	3	2	31, ...	3., ...
20	R2045 80	4	3	2	31, ...	3., ...
25	R2045 20	4	3	2	31, ...	3., ...
30	R2045 70	4	3	2	31, ...	3., ...
35	R2045 30	4	3	2	31, ...	3., ...
E.g.:	R2045 70	3			31, 1676	

1) Maximum rail length 1856 mm, maximum number of holes n_B 30

Instruction for mounting

- ▶ Plastic caps included in scope of supply.
- ▶ Composite ball guide rail also available.

Ordering example 1 (to L_{max})

Options:

- ▶ Ball guide rail NR II, SNS
- ▶ Size 30
- ▶ Accuracy class H
- ▶ One-piece
- ▶ Rail length
L = 1676 mm

Material number:

R2045 703 31, 1676 mm

Ordering example 2 (above L_{max})

Options:

- ▶ Ball guide rail NR II, SNS
- ▶ Size 30
- ▶ Accuracy class H
- ▶ **2 partial sections**
- ▶ Rail length
L = 5116 mm

Material number:

R2045 703 32, 5116 mm

R2047 .0. ... , SNS, for bolting from below

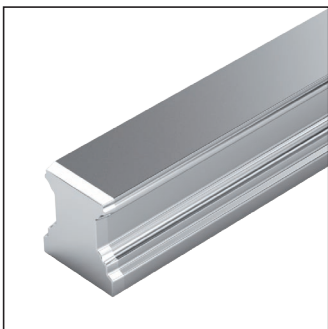

Options and material numbers

Size	Ball guide rail with size	Accuracy class			Number of partial sections, rail length L (mm), ...	
		N	H	P	One-piece	Composite
15 ¹⁾	R2047 10	4	3	2	31, ...	3., ...
20	R2047 80	4	3	2	31, ...	3., ...
25	R2047 20	4	3	2	31, ...	3., ...
30	R2047 70	4	3	2	31, ...	3., ...
35	R2047 30	4	3	2	31, ...	3., ...
E.g.:	R2047 70	3			32, 5116	

1) Maximum rail length 1856 mm, maximum number of holes n_B 30

Instruction for mounting

- ▶ Composite ball guide rail also available.

Ordering example 1 (to L_{max})

Options:

- ▶ Ball guide rail NR II, SNS
- ▶ Size 30
- ▶ Accuracy class H
- ▶ One-piece
- ▶ Rail length L = 1676 mm

Material number:

R2047 703 31, 1676 mm

Ordering example 2 (above L_{max})

Options:

- ▶ Ball guide rail NR II, SNS
- ▶ Size 30
- ▶ Accuracy class H
- ▶ **2 partial sections**
- ▶ Rail length L = 5116 mm

Material number:

R2047 703 32, 5116 mm

Product description

General notes on ball guide rails Resist CR

For material numbers, please refer to the following pages. For recommended rail lengths, dimensions and gravity, see corresponding standard steel ball guide rails. Observe the chapter "Instruction for mounting"!

Please request the "Mounting instructions for ball rail systems" and "Mounting instructions for cover strip".

Accessories: Cover strip, strip clamps, caps, ... for ball guide rails, see chapter "Accessories for ball guide rails"

Corrosion-resistant Resist CR coating

Steel ball guide rail with corrosion-resistant coating, matte-silver finish, hard chrome plated.

Ball guide rails with coated end faces

- ▶ Coated end faces, chamfers and end-face thread, material numbers: – R16.. ... 41 or R16.. ... 71
- ▶ Multi-part ball guide rails are chamfered on two sides at the joints.

Recommended ball runner blocks for ball guide rails Resist CR of accuracy class H and preload class C0 and C1

Size 15 - 65: Accuracy class H, preload class C0

Size 30 - 65: Accuracy class H, preload class C1

Combinations of different accuracy classes

Combining ball guide rails and ball runner blocks of different accuracy classes results in different tolerances for the dimensions H and A3 (see chapter "Accuracy classes and their tolerances").

Ball guide rails Resist CR

R1645 .3. ..., SNS can be bolted from above, with cover strip and strip clamps

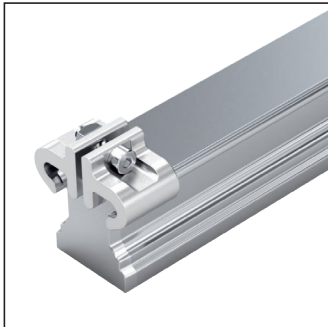

Options and material numbers

Size	Ball guide rail with size	Accuracy class	Number of partial sections, rail length L (mm), ...	
			One-piece Coated end faces	Composite Coated end faces
15	R1645 13	H	41, ...	4., ...
20	R1645 83	H	41, ...	4., ...
25	R1645 23	H	41, ...	4., ...
30	R1645 73	H	41, ...	4., ...
35	R1645 33	H	71, ...	7., ...
45	R1645 43	H	71, ...	7., ...
55	R1645 53	H	71, ...	7., ...
65	R1645 63	H	71, ...	7., ...
E.g.:	R1645 73	H	41, 1676	

Instruction for mounting

- ▶ Secure the cover strip!
- ▶ Strip clamps included in scope of delivery.
- ▶ Composite ball guide rail also available.

Ordering example 1 (to L_{max})

- Options:
- ▶ Ball guide rail CR, SNS
 - ▶ Size 30
 - ▶ Accuracy class H
 - ▶ One-piece
 - ▶ End faces coated
 - ▶ Rail length L = 1676 mm
- Material number:
R1645 733 41, 1676 mm

Ordering example 2 (above L_{max})

- Options:
- ▶ Ball guide rail CR, SNS
 - ▶ Size 30
 - ▶ Accuracy class H
 - ▶ **2 partial sections**
 - ▶ End faces coated
 - ▶ Rail length L = 5116 mm
- Material number:
R1645 733 42, 5116 mm

Ball guide rails Resist CR

R1645 .0. ... SNS can be bolted from above, with plastic caps



Options and material numbers

Size	Ball guide rail with size	Accuracy class	Number of partial sections, rail length L (mm), ...	
			One-piece Coated end faces	Composite Coated end faces
15	R1645 10		3	41, ...
20	R1645 80		3	41, ...
25	R1645 20		3	41, ...
30	R1645 70		3	41, ...
35	R1645 30		3	41, ...
45	R1645 40		3	41, ...
55	R1645 50		3	41, ...
65	R1645 60		3	41, ...
E.g.:	R1645 70		3	41, 1676

Instruction for mounting

- ▶ Plastic caps included in scope of supply.
- ▶ Composite ball guide rail also available.

Ordering example 1 (to L_{max})

- Options:
- ▶ Ball guide rail CR, SNS
 - ▶ Size 30
 - ▶ Accuracy class H
 - ▶ One-piece
 - ▶ End faces coated
 - ▶ Rail length L = 1676 mm

Material number:
R1645 703 41, 1676 mm

Ordering example 2 (above L_{max})

- Options:
- ▶ Ball guide rail CR, SNS
 - ▶ Size 30
 - ▶ Accuracy class H
 - ▶ **2 partial sections**
 - ▶ End faces coated
 - ▶ Rail length L = 5116 mm

Material number:
R1645 703 **42**, 5116 mm

R1647 .0. ... SNS for bolting from below

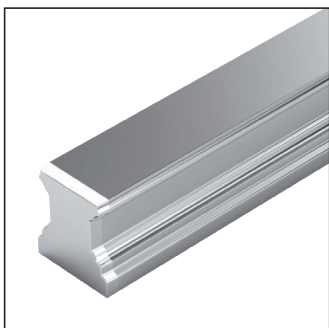

Options and material numbers

Size	Ball guide rail with size	Accuracy class	Number of partial sections, rail length L (mm), ...	
			One-piece Coated end faces	Composite Coated end faces
15	R1647 10		3	41, ...
20	R1647 80		3	41, ...
25	R1647 20		3	41, ...
30	R1647 70		3	41, ...
35	R1647 30		3	41, ...
45	R1647 40		3	41, ...
55	R1647 50		3	41, ...
65	R1647 60		3	41, ...
E.g.:	R1647 70		3	42, 5116

Instruction for mounting

- ▶ Composite ball guide rail also available.

Ordering example 1 (to L_{max})

- Options:
- ▶ Ball guide rail CR, SNS
 - ▶ Size 30
 - ▶ Accuracy class H
 - ▶ One-piece
 - ▶ End faces coated
 - ▶ Rail length L = 1676 mm

Material number:
R1647 703 41, 1676 mm

Ordering example 2 (above L_{max})

- Options:
- ▶ Ball guide rail CR, SNS
 - ▶ Size 30
 - ▶ Accuracy class H
 - ▶ **2 partial sections**
 - ▶ End faces coated
 - ▶ Rail length L = 5116 mm

Material number:
R1647 703 **42**, 5116 mm

Ball guide rails with temperature control, product description

Characteristic features

Faster starting, more precise movement, simple conversion

What used to only be possible with a lot of effort and special solutions is now available for the first time as standard: Rexroth has integrated temperature control into the guide rail. Wherever fast travel cycles and the highest precision are required, guide rails can now be started without any run-in time. Always at the perfect temperature and thermally stable. And with less waste. Ideal for retrofitting: Simply replace the rail and connect to the existing cooling circuit. You can turn your standard machines into precision machines in no time at all!

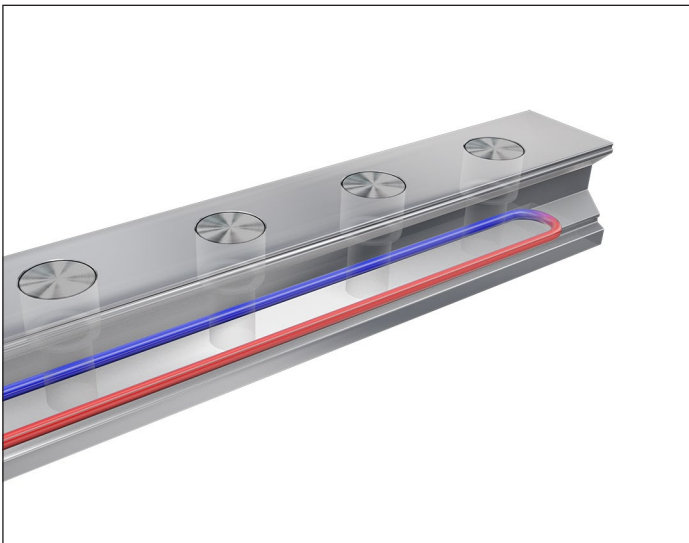
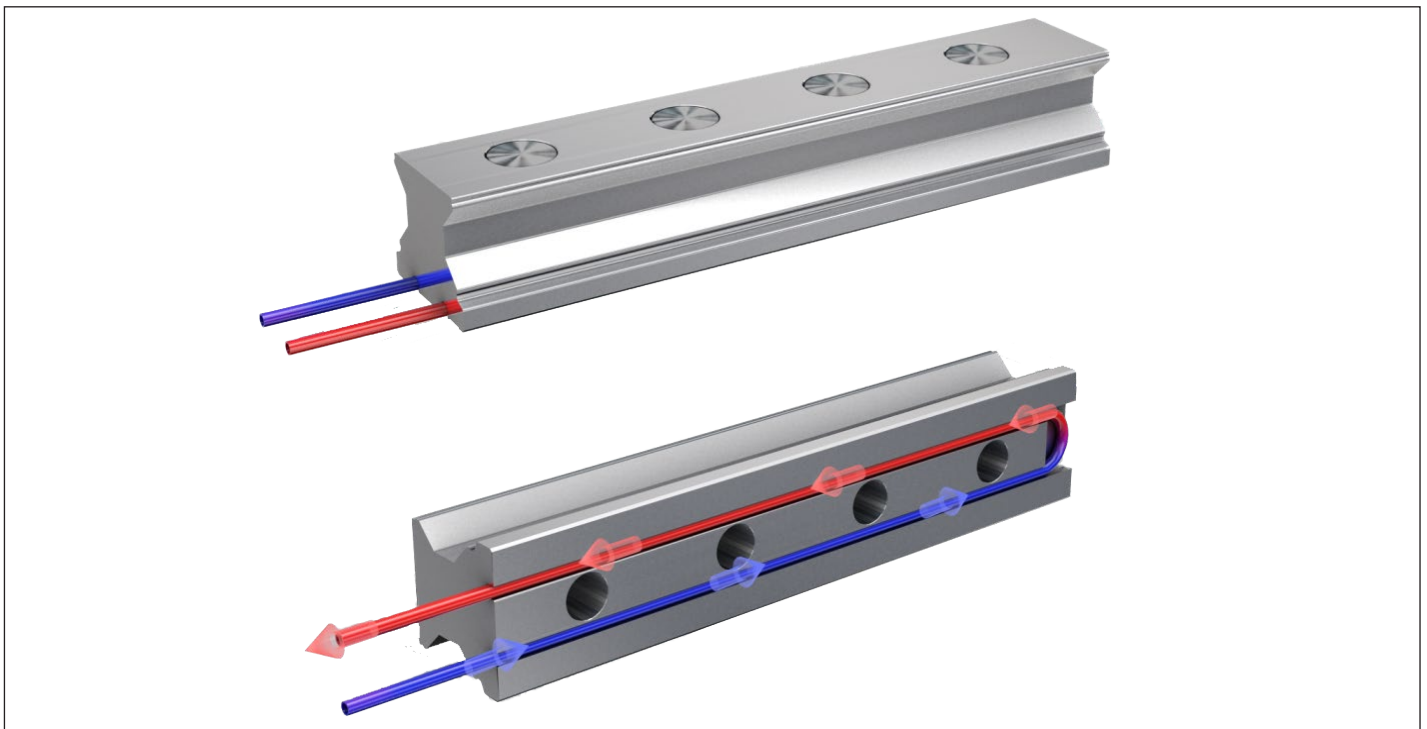

Extremely precise movement, flexible adjustment

Since the new guide rails by Rexroth remove the heat from where it is created or supplies it to where it is needed you have complete freedom. No matter where your machine is positioned or what material the machine bed is made from, the linear guides work with high precision and are thermally stable. No run-in time, with good parts right from the first part onwards. This ensures the greatest availability and increases part accuracy by up to 75%. Even with existing machines: rails can be easily connected to existing cooling circuits with ready to connect piping. Finished.

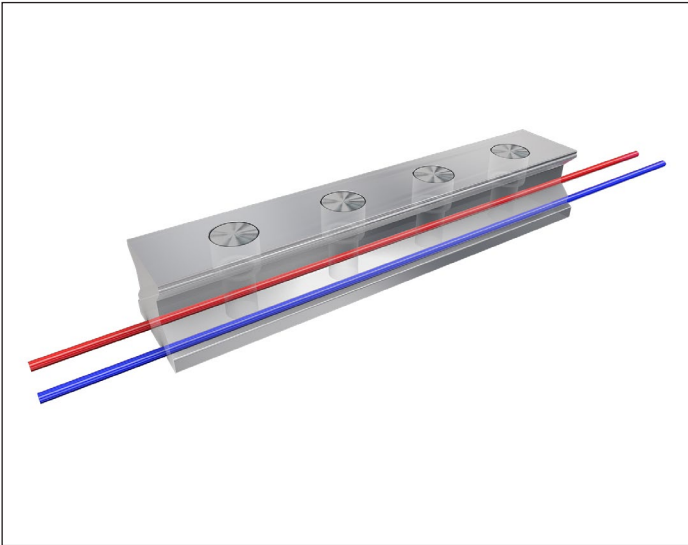

Further highlights

- ▶ High precision: Up to 75% higher part accuracy, regardless of environment
- ▶ Always available: No run-in to the operating temperature
- ▶ Flexible: Can be adjusted to changes as required
- ▶ Can be retrofitted: compatible with existing systems
- ▶ Simple: Pipes are ready to connect, uses existing cooling circuits

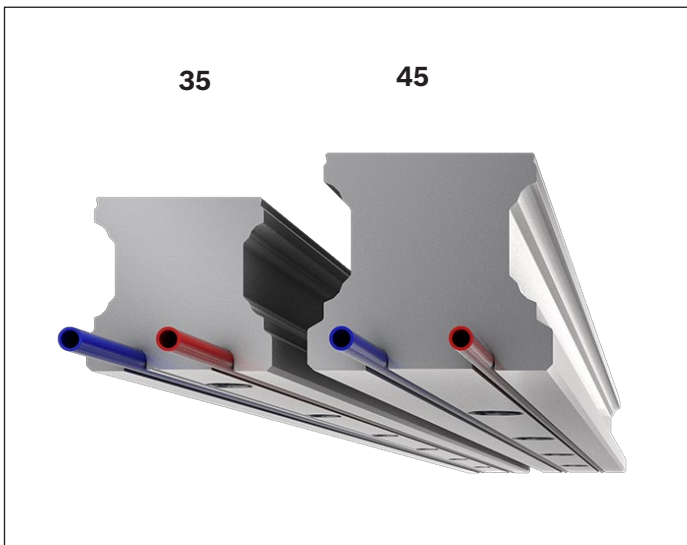

Technical features

- ▶ Ball guide sizes: 35/45
- ▶ Formats: R1605
- ▶ Rail covers: Cover strip, plastic caps
- ▶ Series with groove
- ▶ Accuracy classes: P/SP
- ▶ Rail lengths: Up to max. 4000 mm
- ▶ Redirecting temperature control: To the rails or universal
- ▶ Patent pending

Ball guide rails with temperature control are available on request.
The illustrations partly show the roller guide rail version

Product description

Characteristic features

- ▶ Limitless interchangeability as all ball guide rail systems can be combined at will with all ball runner block versions within each accuracy class.
- ▶ Very high torsional moment load capacity and very high torsion resistance – therefore primarily used as an individual guide
- ▶ High torque load capacity
- ▶ The same high load capacities in all four main directions of loading
- ▶ Integrated all-round sealing
- ▶ Low noise level and optimum travel behavior
- ▶ Excellent dynamic characteristics:
Travel speed: v_{\max} up to 5 m/s ¹⁾
Acceleration: a_{\max} up to 500 m/s² ¹⁾
- ▶ Long-term lubrication is possible over several years
- ▶ Minimum quantity lubrication system with integrated reservoir for oil lubrication¹⁾
- ▶ Lube fittings with metal threads on all sides¹⁾
- ▶ Maximum system rigidity due to preloaded O-arrangement
- ▶ Wide range of accessories

Further highlights

- ▶ Optimized entry-zone geometry and high number of balls minimize variation in elastic deflection
- ▶ End-face fastening thread for all attachments
- ▶ Linear guideway with low clearance or moderate preload
- ▶ Smooth, quiet running thanks to optimally designed ball and ball chain return and guideway¹⁾
- ▶ Attachments on the ball runner block can be bolted from above and below¹⁾
- ▶ Improved rigidity under lift-off and side loading conditions due to two additional mounting screw bores at the center of the ball runner block
- ▶ Ball runner block pre-lubricated at the factory¹⁾
- ▶ Optionally available with ball chain¹⁾
- ▶ Can be used on all ball guide rails BNS

Corrosion protection (optional)

- ▶ Resist CR:
Ball runner block body or ball guide rail made of steel with corrosion-resistant coating, matte-silver finish, hard chrome plated

1) Type-dependent

Size 20/40:

New ball rail system with different ball diameters. Not interchangeable with the old 20/40 size!

Overview of formats

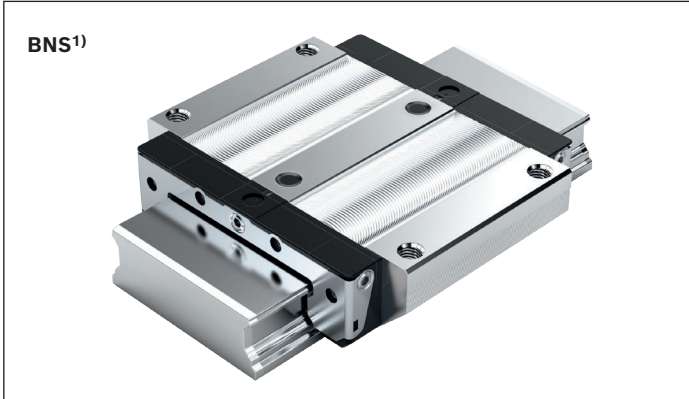

Size 20/40 and 25/70

- ▶ With ball chain
- ▶ Pre-lubricated



Size 35/90

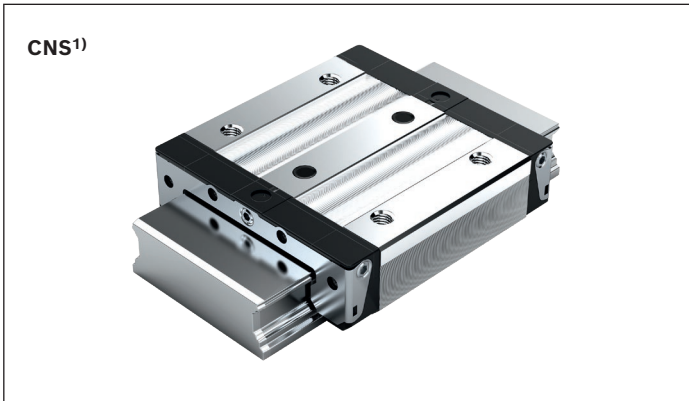

Size 20/40 and 25/70

- ▶ With ball chain
- ▶ Pre-lubricated

Definition of the format of ball runner blocks

Criterion	Designation	Code (example)		
		B	N	S
Width	Flange (F)	F		
	Slimline (S)	S		
	Wide (B)	B		
	Compact (C)	C		
Length	Normal (N)		N	
	Long (L)		L	
	Short (K)		K	
Height	Standard height (S)			S
	High (H)			H
	Low (N)			N



Ball chain (optional)

- ▶ Optimized noise level

BNS – Wide, normal, standard height

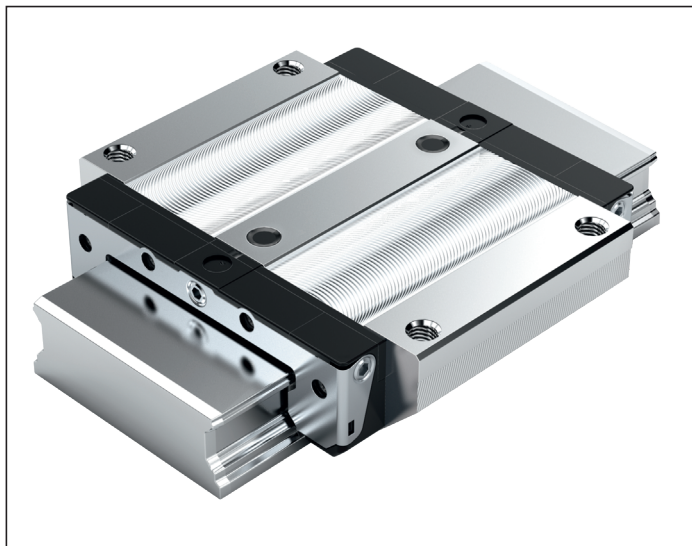

Ball runner blocks made of steel

R1671 ... 2.

Dynamic characteristics

Travel speed: $v_{max} = 5 \text{ m/s}$

Acceleration: $a_{max} = 500 \text{ m/s}^2$

(If $F_{comb} > 2.8 \cdot F_{pr}$: $a_{max} = 50 \text{ m/s}^2$)

Note on lubrication:

- ▶ Pre-lubricated

Further ball runner blocks BNS

- ▶ Corrosion-resistant ball runner blocks see below

Options and material numbers

Size	Ball runner block with size	Preload class		Accuracy class			Seal on ball runner block			
		C0	C1	N	H	P	without ball chain		with ball chain	
							SS	DS	SS	DS
20/40 ¹⁾	R1671 5	9		4	3	–	20	–	22	–
			1	4	3	2	20	2Z	22	2Y
25/70	R1671 2	9		4	3	–	20	–	22	–
			1	4	3	2	20	2Z	22	2Y
E.g.:	R1671 2		1		3		20			

Ordering example

Options:

- ▶ Ball runner block BNS
- ▶ Size 25/70
- ▶ Preload class C1
- ▶ Accuracy class H
- ▶ With standard seal, without ball chain

Material number:

R1671 213 20

Ball runner blocks Resist CR

R1671 ... 7.

Note on lubrication:

- ▶ Pre-lubricated

Ordering example

Options:

- ▶ Ball runner block BNS
- ▶ Size 25/70
- ▶ Preload class C0
- ▶ Accuracy class H
- ▶ With standard seal, without ball chain

Material number:

R1671 293 70

Options and material numbers

Size	Ball runner block with size	Preload class	Accuracy class	Seal on ball runner block			
				without ball chain		with ball chain	
		C0	H	SS	DS	SS	DS
20/40 ¹⁾	R1671 5	9	3	70	7Z	72	7Y
25/70	R1671 2	9	3	70	7Z	72	7Y
E.g.:	R1671 2	9	3	70			

1) Caution: Ball runner blocks, not combinable with ball guide rail R167.8.. ...!

Preload classes

C0 = Without preload (clearance)
C1 = Moderate preload

Seals

SS = Standard seal
DS = Double-lip seal

Key

gray numbers
= no preferred variant / combination
(partially longer delivery times)

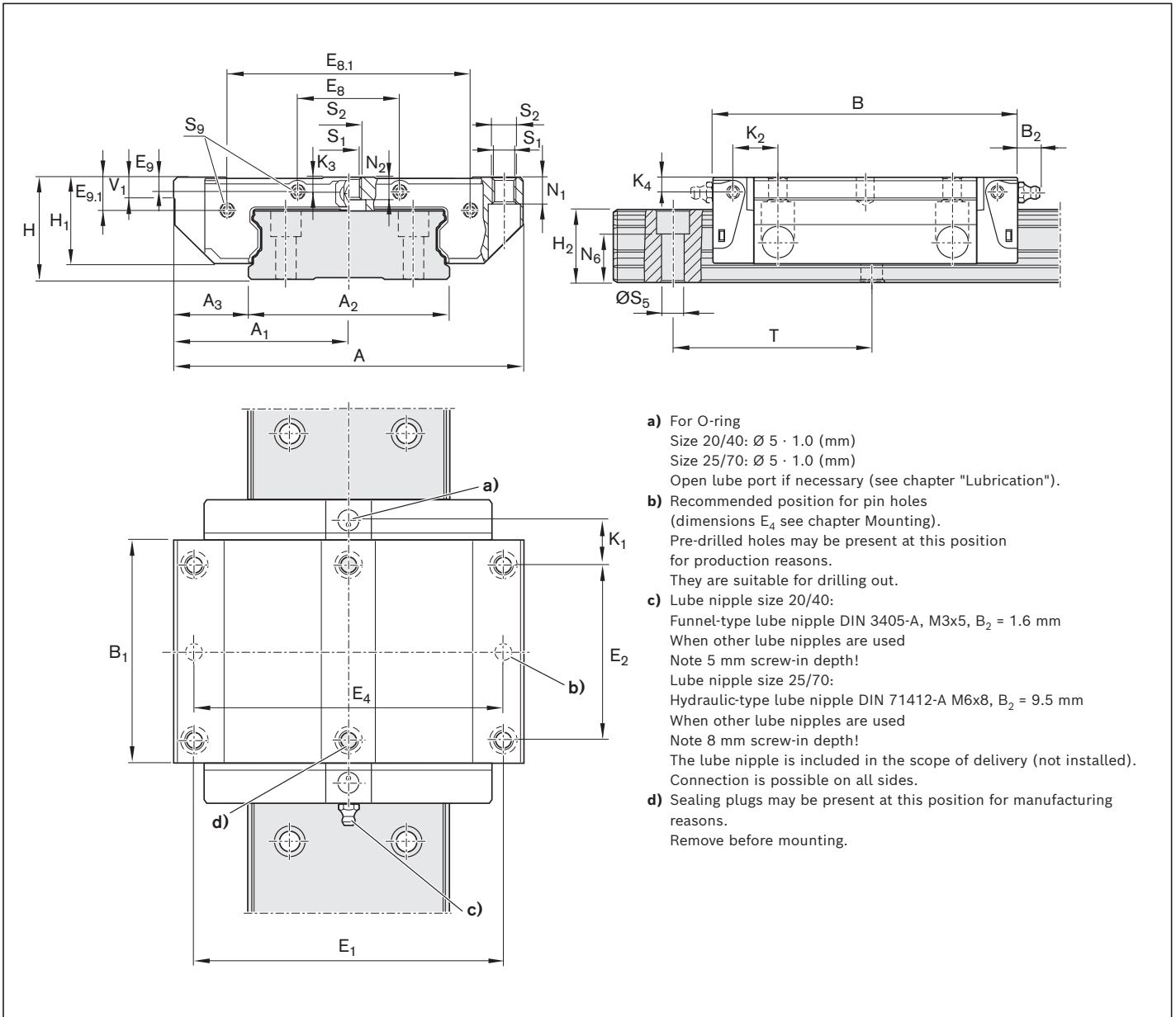

Size	Dimensions (mm)																		
	A	A ₁	A ₂	A ₃	B	B ₁	E ₁	E ₂	E ₈	E _{8.1}	E ₉	E _{9.1}	H	H ₁	H ₂	K ₁	K ₂	K ₃	K ₄
20/40	80	40	42	19.0	73	51.3	70	40	18	53.4	3.4	8.1	27	22.50	18.30	10.6	11.0	3.5	3.5
25/70	120	60	69	25.5	105	76.5	107	60	35	83.5	4.9	11.3	35	29.75	23.55	15.4	15.5	5.2	5.2

Size	Dimensions (mm)										Mass (kg)	Load capacities ¹⁾ (N)		Load moments ¹⁾ (Nm)			
	N ₁	N ₂	N ₆ ^{±0.5}	S ₁	S ₂	S ₅	S ₉	T	V ₁	C		C ₀	M _t	M _{t0}	M _L	M _{Lo}	
20/40	7.70	3.70	12.5	5.3	M6	4.4	M2.5x1.5 ⁺³	60	6.0	0.4	14900	20600	340	470	140	190	
25/70	9.35	7.05	14.4	6.7	M8	7.0	M3x2 ^{+4.5}	80	7.5	1.2	36200	50200	1,350	1870	490	680	

1) Load capacities and load moments for ball runner block **without** ball chain. Load capacities and load moments for ball runner block **with** ball chain 14

Determination of the dynamic load capacities and load moments is based on a stroke travel of 100,000 m according to DIN ISO 14728-1. Often only 50,000 m are actually stipulated. For comparison: Multiply the values **C**, **M_t** and **M_L** by 1.26 according to the table.

BNS – Wide, normal, standard height

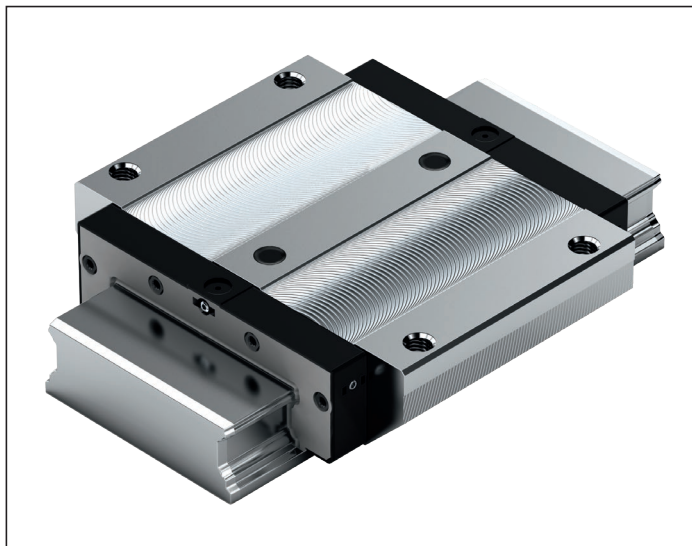

Ball runner blocks made of steel
R1671 ... 1.

Dynamic characteristics

Travel speed: $v_{max} = 3 \text{ m/s}$

Acceleration: $a_{max} = 250 \text{ m/s}^2$

(If $F_{comb} > 2.8 \cdot F_{pr}$: $a_{max} = 50 \text{ m/s}^2$)

Note on lubrication:

- ▶ No initial lubrication

Further ball runner blocks BNS

- ▶ Corrosion-resistant ball runner blocks see below

Ordering example

Options:

- ▶ Ball runner block BNS
- ▶ Size 35/90
- ▶ Preload class C1
- ▶ Accuracy class H
- ▶ With standard seal, without ball chain

Material number:

R1671 313 10

Options and material numbers

Size	Ball runner block with size	Preload class			Accuracy class			Seal on ball runner block without ball chain	SS
		C0	C1	C2	N	H	P		
35/90	R1671 3	9			4	3	-	10	
			1		4	3	2	10	
				2		3	2	10	
E.g.:	R1671 3		1			3		10	

Ball runner blocks Resist CR

R1671 ... 6.

Ordering example

Options:

- ▶ Ball runner block BNS
- ▶ Size 35/90
- ▶ Preload class C1
- ▶ Accuracy class H
- ▶ With standard seal, without ball chain

Material number:

R1671 313 60

Options and material numbers

Size	Ball runner block with size	Preload class		Accuracy class	Seal on ball runner block without ball chain	SS
		C0	C1			
35/90	R1671 3	9	1		H	60
E.g.:	R1671 3		1		3	60

Preload classes

C0 = Without preload (clearance)
C1 = Moderate preload

Seals

SS = Standard seal

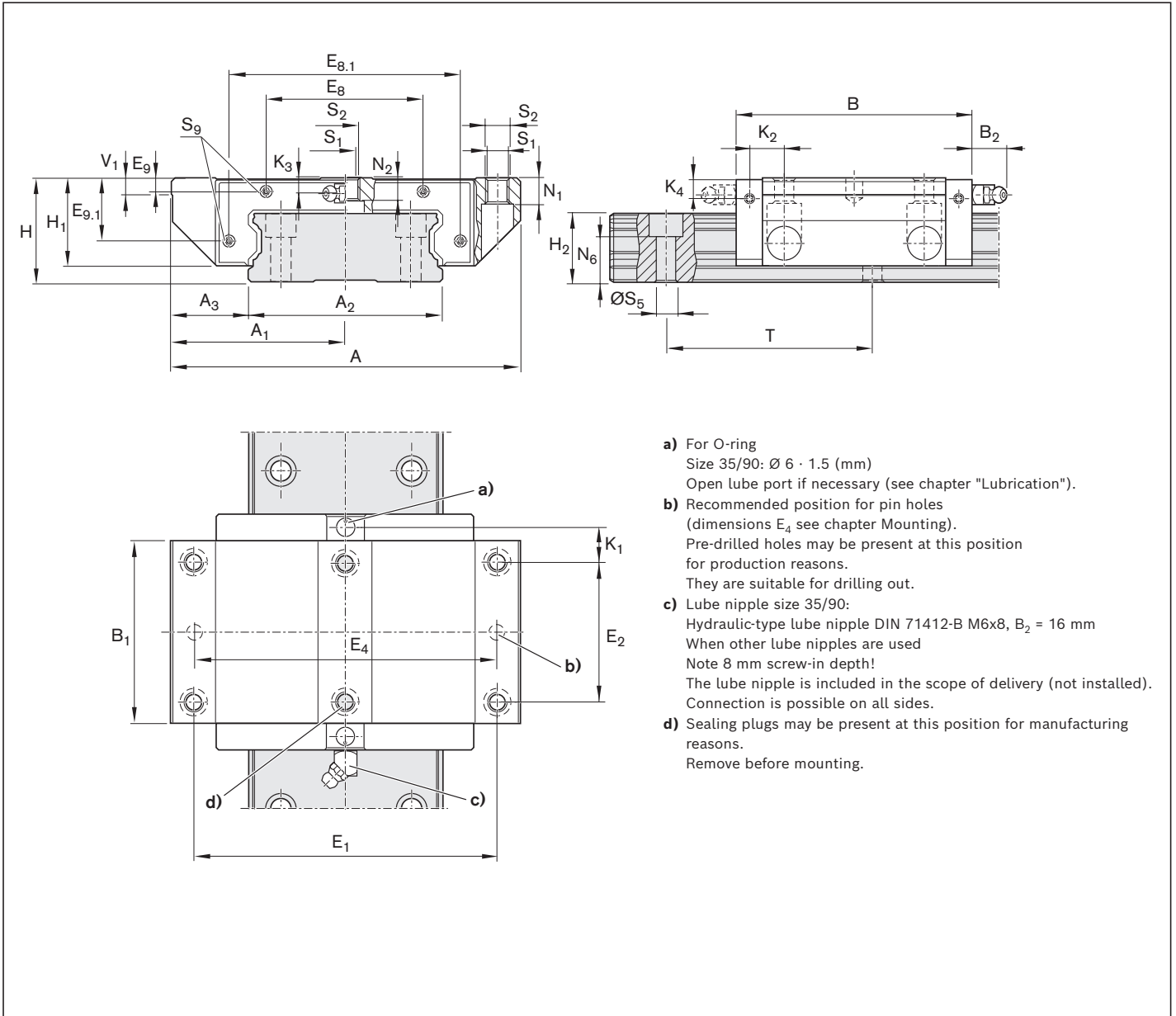

- a) For O-ring
Size 35/90: $\varnothing 6 \cdot 1.5$ (mm)
Open lube port if necessary (see chapter "Lubrication").
- b) Recommended position for pin holes
(dimensions E_4 see chapter Mounting).
Pre-drilled holes may be present at this position for production reasons.
They are suitable for drilling out.
- c) Lube nipple size 35/90:
Hydraulic-type lube nipple DIN 71412-B M6x8, $B_2 = 16$ mm
When other lube nipples are used
Note 8 mm screw-in depth!
The lube nipple is included in the scope of delivery (not installed).
Connection is possible on all sides.
- d) Sealing plugs may be present at this position for manufacturing reasons.
Remove before mounting.

Size	Dimensions (mm)																
	A	A ₁	A ₂	A ₃	B	B ₁	E ₁	E ₂	E ₈	E _{8.1}	E ₉	E _{9.1}	H	H ₁	H ₂	K ₁	K ₂
35/90	162	81	90	36	142	113.6	144	80	79	116	6.8	29.9	50	42.5	31.85	22.8	24.8

Size	Dimensions (mm)											Mass (kg)	Load capacities ¹⁾ (N)		Load moments ¹⁾ (Nm)			
	K ₃	K ₄	N ₁	N ₂	N ₆ ^{±0.5}	S ₁	S ₂	S ₅	S ₉	T	V ₁		C	C ₀	M _t	M _{t0}	M _L	M _{L0}
35/90	9	9	14	12	20.5	8.4	M10	9	M3x5	80	8.0	3.70	70700	126000	3500	6240	1470	2620

1) Load capacities and load moments for ball runner block **without** ball chain.
 Determination of the dynamic load capacities and load moments is based on a stroke travel of 100,000 m according to DIN ISO 14728-1. Often only 50,000 m are actually stipulated. For comparison: Multiply the values **C**, **M_t** and **M_L** by 1.26 according to the table.

CNS – Compact, normal, standard height

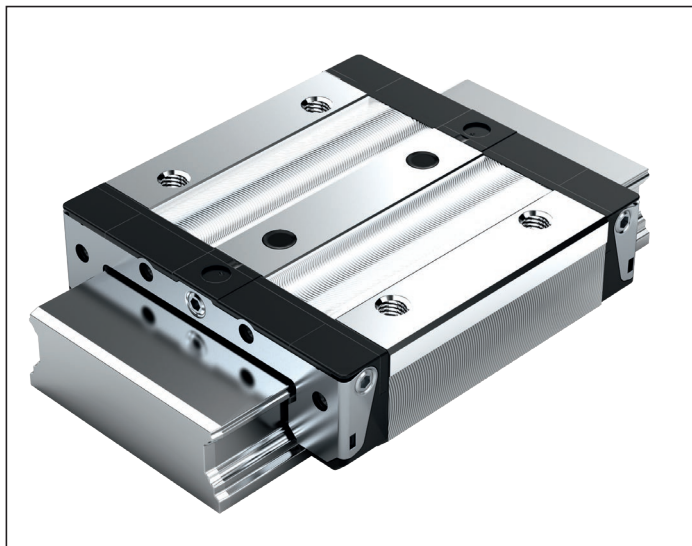

Ball runner blocks made of steel
R1672 ... 2.

Dynamic characteristics

Travel speed: $v_{max} = 5 \text{ m/s}$

Acceleration: $a_{max} = 500 \text{ m/s}^2$

(If $F_{comb} > 2.8 \cdot F_{pr}$: $a_{max} = 50 \text{ m/s}^2$)

Note on lubrication:

- ▶ Pre-lubricated

Further ball runner blocks CNS

- ▶ Corrosion-resistant ball runner blocks see below

Ordering example

Options:

- ▶ Ball runner block CNS
- ▶ Size 25/70
- ▶ Preload class C1
- ▶ Accuracy class H
- ▶ With standard seal, without ball chain

Material number:

R1672 213 20

Options and material numbers

Size	Ball runner block with size	Preload class		Accuracy class			Seal on ball runner block			
		C0	C1	N	H	P	without ball chain		with ball chain	
							SS	DS	SS	DS
20/40 ¹⁾	R1672 5	9		4	3	-	20	-	22	-
			1	4	3	-	20	2Z	22	2Y
25/70	R1672 2	9		4	3	-	20	-	22	-
			1	4	3	-	20	2Z	22	2Y
E.g.:	R1672 2		1		3		20			

Ball runner blocks Resist CR²⁾

R1672 ... 7.

Ordering example

Options:

- ▶ Ball runner block CNS
- ▶ Size 25/70
- ▶ Preload class C0
- ▶ Accuracy class H
- ▶ With standard seal, without ball chain

Material number:

R1672 293 70

Options and material numbers

Size	Ball runner block with size	Preload class	Accuracy class	Seal on ball runner block				
				without ball chain		with ball chain		
		C0		H	SS	DS	SS	DS
20/40 ¹⁾	R1672 5	9		3	70	7Z	72	7Y
25/70	R1672 2	9		3	70	7Z	72	7Y
E.g.:	R1672 2	9		3	70			

1) Caution: Ball runner blocks, not combinable with ball guide rail R167.8.. ...!

Preload classes

C0 = Without preload (clearance)
C1 = Moderate preload

Seals

SS = Standard seal
DS = Double-lip seal

Key

gray numbers
= no preferred variant / combination
(partially longer delivery times)

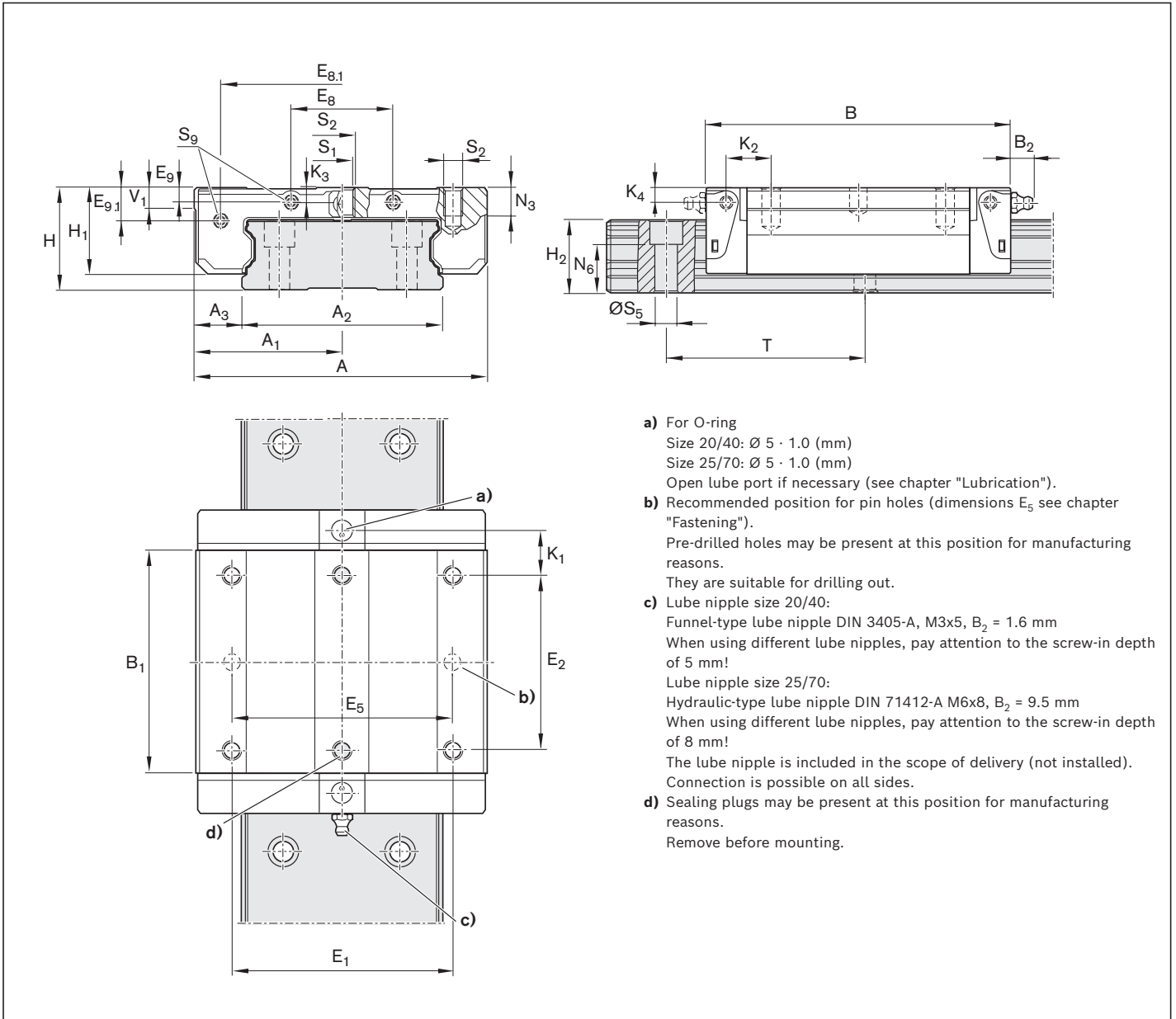

- a)** For O-ring
 Size 20/40: $\varnothing 5 \cdot 1.0$ (mm)
 Size 25/70: $\varnothing 5 \cdot 1.0$ (mm)
 Open lube port if necessary (see chapter "Lubrication").
- b)** Recommended position for pin holes (dimensions E_5 see chapter "Fastening").
 Pre-drilled holes may be present at this position for manufacturing reasons.
 They are suitable for drilling out.
- c)** Lube nipple size 20/40:
 Funnel-type lube nipple DIN 3405-A, M3x5, $B_2 = 1.6$ mm
 When using different lube nipples, pay attention to the screw-in depth of 5 mm!
 Lube nipple size 25/70:
 Hydraulic-type lube nipple DIN 71412-A M6x8, $B_2 = 9.5$ mm
 When using different lube nipples, pay attention to the screw-in depth of 8 mm!
 The lube nipple is included in the scope of delivery (not installed).
 Connection is possible on all sides.
- d)** Sealing plugs may be present at this position for manufacturing reasons.
 Remove before mounting.

Size	Dimensions (mm)																		
	A	A ₁	A ₂	A ₃	B	B ₁	E ₁	E ₂	E ₈	E _{8.1}	E ₉	E _{9.1}	H	H ₁	H ₂	K ₁	K ₂	K ₃	K ₄
20/40	62	31	42	10.0	73.0	51.3	46	32	18	53.4	3.4	8.1	27	22.50	18.30	14.6	15.00	3.5	3.5
25/70	100	50	69	15.5	104.7	76.5	76	50	35	83.5	4.9	11.3	35	29.75	23.55	19.4	20.45	5.2	5.2

Size	Dimensions (mm)									Mass (kg)	Load capacities ¹⁾ (N)		Load moments ¹⁾ (Nm)			
	N ₃	N ₆ ^{±0.5}	S ₁	S ₂	S ₅	S ₉	T	V ₁	C		C ₀	M _t	M _{t0}	M _L	M _{L0}	
20/40	6	12.5	5.3	M6	4.4	M2.5x1.5 ⁺³	60	6.0	0.3	14900	20600	340	470	140	190	
25/70	8	14.4	6.7	M8	7.0	M3x2 ^{+4.5}	80	7.5	1.0	36200	50200	1,350	1870	490	680	

1) Load capacities and load moments for ball runner block **without** ball chain. Load capacities and load moments for ball runner block **with** ball chain 14

Determination of the dynamic load capacities and load moments is based on a stroke travel of 100,000 m according to DIN ISO 14728-1. Often only 50,000 m are actually stipulated. For comparison: Multiply the values **C**, **M_t** and **M_L** by 1.26 according to the table.

Product description

Characteristic features

- ▶ Maximum rigidity in all directions of loading
- ▶ Maximum torque load capacity

Corrosion protection (optional)

- ▶ Resist CR:
Ball guide rail made of steel with corrosion-resistant coating, matte-silver finish, hard chrome plated, accuracy class H



Ball guide rails with plastic caps

⚠ Size 20/40:

Ball rail system with other ball diameters.
Not interchangeable with the old 20/40 size!

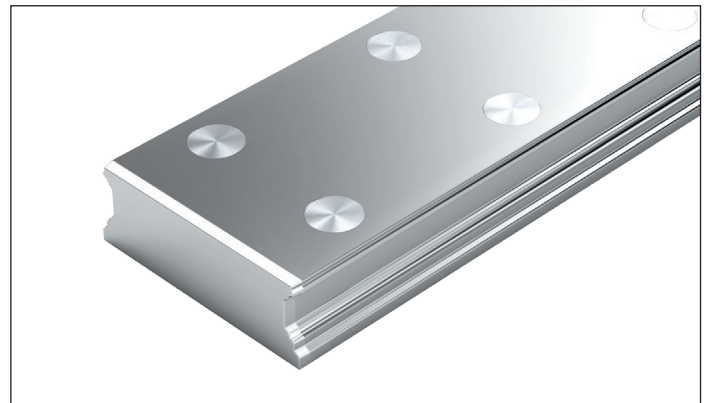

Ball guide rails with steel caps

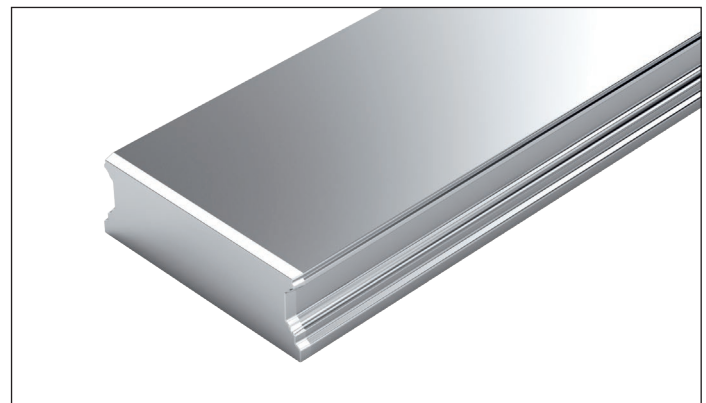

Ball guide rails for bolting from below

Definition of the format of ball guide rails

Criterion	Designation	Code (example)		
		B	N	S
Width	Slimline (S)	S		
	Wide (B)	B		
Length	Normal (N)		N	
Height	Standard height (S)			S

Ordering guide rails in the recommended rail lengths

Ordering ball guide rails in the recommended rail lengths

The procedure shown in the following ordering examples applies to all ball guide rails. Recommended rail lengths are more cost effective.

From the desired rail length to the recommended length

$$L = \left(\frac{L_W}{T} \right)^* \cdot T - 4$$

* Round up quotient L_W/T to the nearest whole number!

Calculation example

$$L = \left(\frac{1660 \text{ mm}}{80 \text{ mm}} \right) \cdot 80 \text{ mm} - 4 \text{ mm}$$

$$L = 21 \cdot 80 \text{ mm} - 4 \text{ mm}$$

$$L = 1676 \text{ mm}$$

Notes on ordering examples

If preferred dimension T_{1S} is not used, it is possible to choose between:

- ▶ Select end spacing T_1 between T_{1S} and T_{1min}
- ▶ As an alternative, it is possible to choose end spacings T_1 to T_{1max} .

Options and material numbers								
Size	Ball guide rail with size	Accuracy class			Number of partial sections, Rail length L (mm), ...		Spacing T (mm)	Recommended rail length in accordance with formula $L = n_B \cdot T - 4 \text{ mm}$ Maximum number of holes n_B
		N	H	P	One-piece	Composite		
20/40 ¹⁾	R1675 50	4	3	2	31, ...	3, ...	60	64
25/70	R1675 20	4	3	2	31, ...	3, ...	80	48
35/90	R1675 30	4	3	2	31, ...	3, ...	80	48
E.g.:	R1675 30		3		31, 1676			

Excerpt from table with material numbers and recommended rail lengths for ordering example

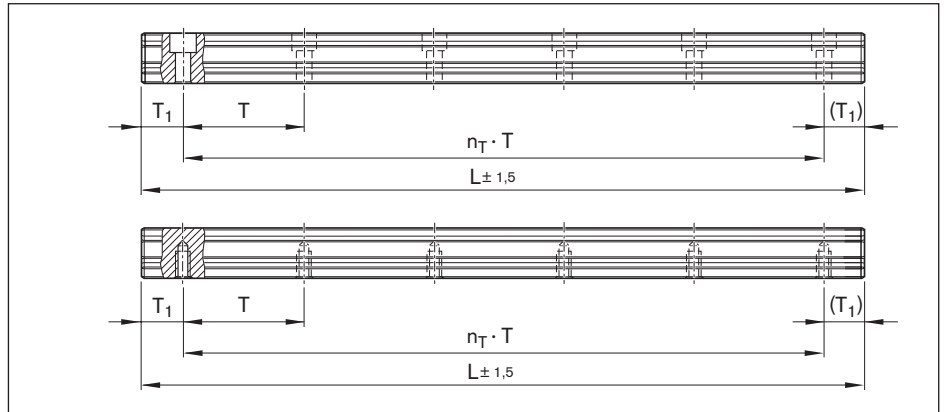

Basis: Number of holes per drill row

$$L = n_B \cdot T - 4$$

Basis: Number of spaces

$$L = n_T \cdot T + 2 \cdot T_{1S}$$

L = Recommended rail length (mm)

L_W = Desired rail length (mm)

T = Spacing (mm)

T_{1S} = Preferred dimension (mm)

n_B = Number of holes per drill row (-)

n_T = Number of spaces (-)

Ordering example 1 (to L_{max})

- ▶ Ball guide rail BNS size 35/90 with plastic caps
- ▶ Accuracy class H
- ▶ Calculated rail length 1676 mm, ($20 \cdot T$, preferred dimension $T_{1S} = 38 \text{ mm}$; number of holes per drill row $n_B = 21$)

Ordering data

Material number, rail length (mm)

$T_1 / n_T \cdot T / T_1$ (mm)

R1675 303 31, 1676 mm

38 / 20 · 80 / 38 mm

Ordering example 2 (above L_{max})

- ▶ Ball guide rail BNS size 35/90 with plastic caps
- ▶ Accuracy class H
- ▶ Calculated rail length 5116 mm, 2 sections ($63 \cdot T$, preferred dimension $T_{1S} = 38 \text{ mm}$; number of holes per drill row $n_B = 64$)

Ordering data

Material number with number of partial sections, rail length (mm)

$T_1 / n_T \cdot T / T_1$ (mm)

R1675 303 32, 5116 mm

38 / 63 · 80 / 38 mm

In the case of rail lengths above L_{max} , factory-coordinated partial sections are joined together.

BNS with plastic caps



Ball guide rails made of steel

R1675 .0. ..

With two-row hole pattern, for bolting from above with plastic caps

Notes

- ▶ Plastic caps included in scope of supply.
- ▶ Observe the instruction for mounting!
Please request the "Mounting instructions for ball rail systems."
- ▶ Composite ball guide rail also available.

Further ball guide rails BNS and accessories

- ▶ Corrosion-resistant ball guide rails see below
- ▶ Caps see chapter "Accessories for ball guide rails"

Options and material numbers

Size	Ball guide rail with size	Accuracy class			Number of partial sections, rail length L (mm), ...		Hole spacing T (mm)	Recommended rail length in accordance with formula $L = n_B \cdot T - 4$ Maximum number of holes per drill row n_B
		N	H	P	One-piece	Composite		
20/40 ¹⁾	R1675 50	4	3	2	31, ...	3., ...	60	64
25/70	R1675 20	4	3	2	31, ...	3., ...	80	48
35/90	R1675 30	4	3	2	31, ...	3., ...	80	48
E.g.:	R1675 30	3			31, 1676			

Ball guide rails Resist CR

R1673 .0. ..

Options and material numbers

Size	Ball guide rail with size	Accuracy class			Number of partial sections, rail length L (mm), ...			Hole spacing T (mm)	Recommended rail length in accordance with formula $L = n_B \cdot T - 4$ Maximum number of holes per drill row n_B
		H	Uncoated end faces	Coated end faces	Composite Coated end faces				
20/40 ¹⁾	R1673 50		3	31, ...	41, ...	4., ...	60	64	
25/70	R1673 20		3	31, ...	41, ...	4., ...	80	48	
35/90	R1673 30		3	31, ...	41, ...	4., ...	80	48	
E.g.:	R1673 30		3	42, 5116					

1) Caution: Ball guide rail cannot be combined with ball runner block R1671 8.. ..!

Ordering example 1 (to L_{max})

Options:

- ▶ Ball guide rail BNS
- ▶ Size 35/90
- ▶ Accuracy class H
- ▶ One-piece
- ▶ End faces uncoated
- ▶ Rail length L = 1676 mm

Material number: R1675 303 31, 1676 mm

Ordering example 2 (above L_{max})

Options:

- ▶ Ball guide rail CR, BNS
- ▶ Size 35/90
- ▶ Accuracy class H
- ▶ **2 partial sections**
- ▶ End faces coated
- ▶ Rail length L = 5116 mm

Material number: R1673 303 42, 5116 mm

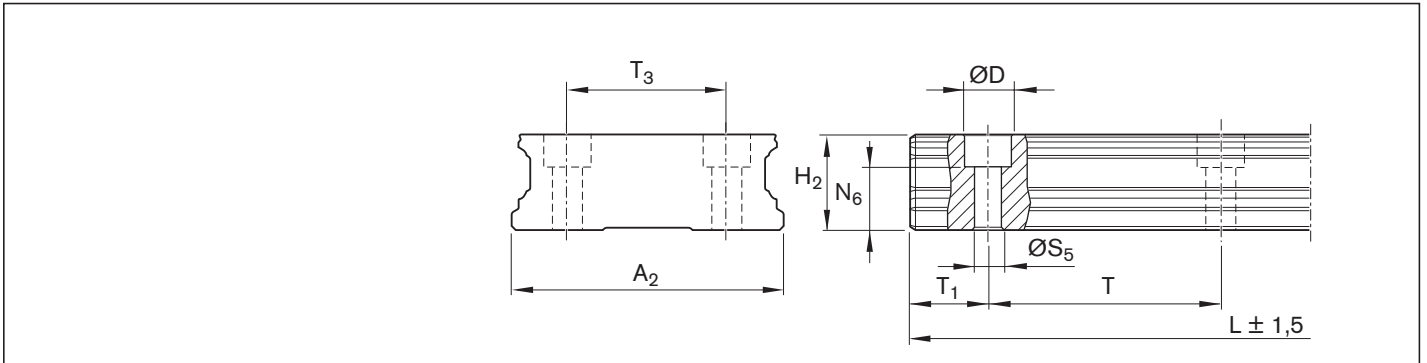

Size	Dimensions (mm)											Mass (kg/m)
	A_2	D	H_2 ¹⁾	L_{max}	$N_6^{\pm 0.5}$	S_5	T	$T_{1 min}$	T_{1S} ²⁾	$T_{1 max}$	T_3	
20/40	42	7.4	18.30	3836	12.45	4.4	60	10	28	50	24	5.3
25/70	69	11.0	23.55	3836	14.50	7.0	80	10	38	70	40	11.6
35/90	90	15.0	31.85	3836	20.50	9.0	80	12	38	68	60	21.0

1) Dimension H_2 without cover strip

2) Recommended: Preferred dimension T_{1S} with tolerances ± 0.75 .

BNS with caps made of steel

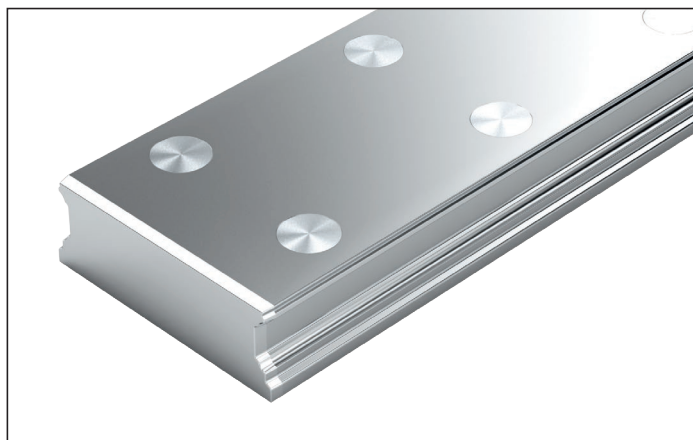

Ball guide rails made of steel R1676 .5. ..
With two-row hole pattern, for bolting from above with caps made of steel

Notes

- ▶ Caps made of steel not included in scope of delivery.
- ▶ Observe the instruction for mounting!
Please request the "Mounting instructions for ball rail systems."
- ▶ Composite ball guide rail also available.

Accessories

- ▶ Caps, mounting tool for caps see chapter "Accessories for ball guide rails"

Options and material numbers

Size	Ball guide rail with size	Accuracy class			Number of partial sections, rail length L (mm), ...		Hole spacing T (mm)	Recommended rail length in accordance with formula $L = n_B \cdot T - 4$	
		N	H	P	One-piece	Composite		Maximum number of holes per drill row n_B	
25/70	R1676 25	4	3	2	31, ...	3., ...	80	48	
35/90	R1676 35	4	3	2	31, ...	3., ...	80	48	
E.g.:	R1676 35	3			31, 1676				

Ordering example 1 (to L_{max})

Options:

- ▶ Ball guide rail BNS
- ▶ Sizes 35/90
- ▶ Accuracy class H
- ▶ One-piece
- ▶ Rail length L = 1676 mm

Material number: R1676 353 31, 1676 mm

Ordering example 2 (above L_{max})

Options:

- ▶ Ball guide rail BNS
- ▶ Sizes 35/90
- ▶ Accuracy class H
- ▶ **2 partial sections**
- ▶ Rail length L = 5116 mm

Material number: R1676 353 32, 5116 mm

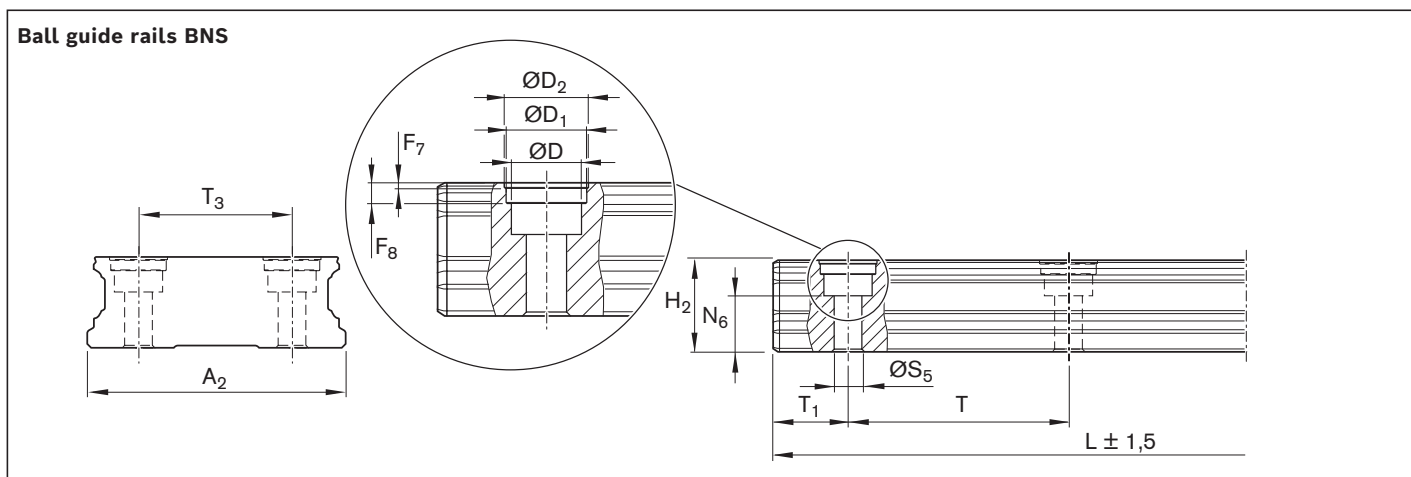

Size	Dimensions (mm)															Mass (kg/m)
	A ₂	D	D ₁	D ₂	F ₇	F ₈	H ₂ ¹⁾	L _{max}	N ₆ ^{±0.5}	S ₅	T	T _{1 min}	T ₁₅ ²⁾	T _{1 max}	T ₃	
25/70	69	11.0	12.55	13	0.9	3.7	23.55	3836	14.5	7.0	80	10	38	70	40	11.6
35/90	90	15.0	17.55	18	0.9	3.6	31.85	3836	20.5	9.0	80	12	38	68	60	21.0

1) Dimension H₂ without cover strip

2) Recommended: preferred dimension T₁₅ with tolerances ±0.75.

BNS for bolting from below

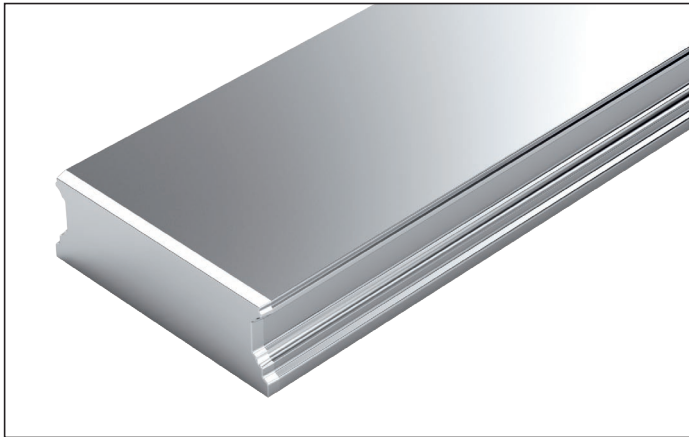

Ball guide rails made of steel R1677 .0. ..
With double-row hole pattern for bolting from below

Notes

- ▶ Observe the instruction for mounting!
Please request the "Mounting instructions for ball rail systems."
- ▶ Composite ball guide rail also available.

Options and material numbers

Size	Ball guide rail with size	Accuracy class			Number of partial sections, rail length L (mm), ...		Hole spacing T (mm)	Recommended rail length in accordance with formula $L = n_B \cdot T - 4$	
		N	H	P	One-piece	Composite		Maximum number of holes per drill row n_B	
20/40 ¹⁾	R1677 50	4	3	2	31, ...	3., ...	60	64	
25/70	R1677 20	4	3	2	31, ...	3., ...	80	48	
35/90	R1677 30	4	3	2	31, ...	3., ...	80	48	
E.g.:	R1677 30	3			31, 1676				

1) Caution: Ball guide rail cannot be combined with ball runner block R1671 8.. ...!

Ordering example 1 (to L_{max})

Options:

- ▶ Ball guide rail BNS,
- ▶ Size 35/90,
- ▶ Accuracy class H,
- ▶ One-piece
- ▶ Rail length L = 1676 mm

Material number: R1677 303 31, 1676 mm

Ordering example 2 (above L_{max})

Options:

- ▶ Ball guide rail BNS,
- ▶ Size 35/90,
- ▶ Accuracy class H,
- ▶ **2 partial sections**
- ▶ Rail length L = 5116 mm

Material number: R1677 303 32, 5116 mm

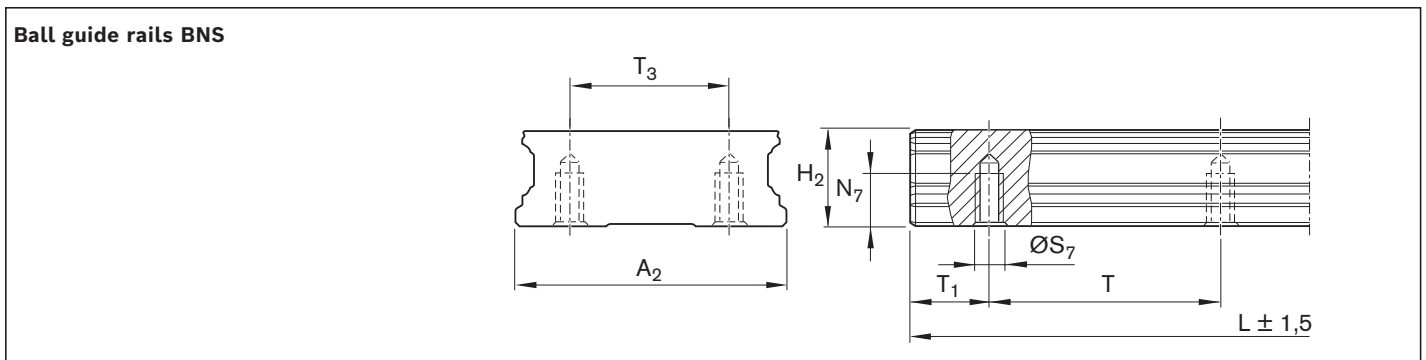







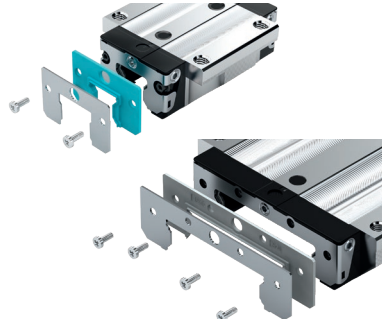
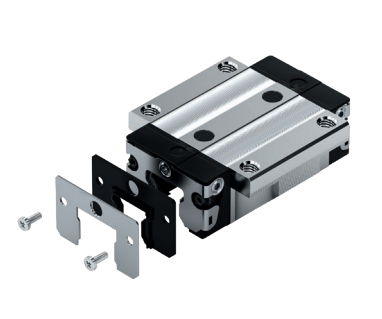
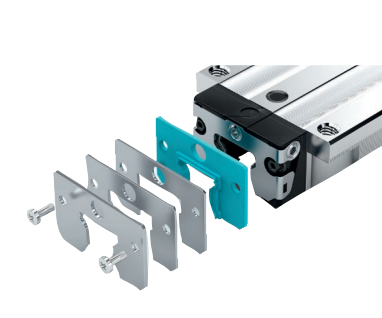

Size	Dimensions (mm)										Mass (kg/m)
	A ₂	H ₂ ¹⁾	L _{max}	N ₇	S ₇	T	T _{1min}	T _{1S} ²⁾	T _{1max}	T ₃	
20/40	42	18.30	3836	7.5	M5	60	10	28	50	24	5.3
25/70	69	23.55	3836	12.0	M6	80	10	38	70	40	11.6
35/90	90	31.85	3836	15.0	M8	80	12	38	68	60	21.0

- 1) Dimension H₂ without cover strip
- 2) Recommended: preferred dimension T_{1S} with tolerances ±0.75.

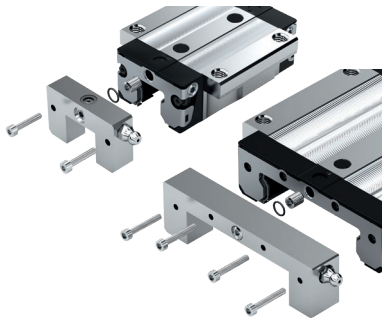
Product description

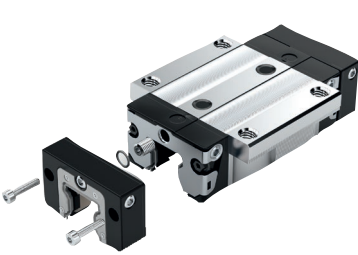
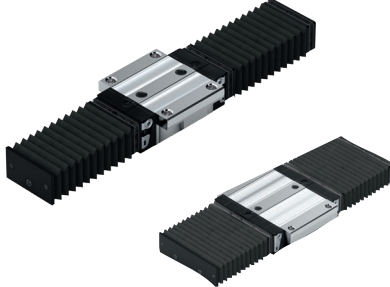
Rexroth offers limitless interchangeability as all ball runner block versions can be combined at will with all accessories within each size. The entire range is ideally geared to enable a top performance and meet all special requirements. Accessories can also be supplied ready-mounted on request.

Overview of ball runner block accessories

<p>Cover plate wiper</p> 	<p>Two-piece front seal¹⁾</p> 	<p>One and two-piece FKM seal¹⁾</p> 
<p>Seal kit¹⁾</p> 	<p>Lubrication adapter only for existing systems with high ball runner blocks SNH or SLH¹⁾</p> 	<p>Lubrication plate¹⁾</p> 
<p>Transport lock</p> 	<p>Front lube unit</p> 	<p>Bellows</p> 
<p>Lube nipple</p> 	<p>Plastic tube for lube connection</p>  <p>O-rings</p> 	<p>Lube fittings</p>  <ul style="list-style-type: none"> ▶ Reducers ▶ Extensions ▶ Connectors ▶ Swivel fittings ▶ Swivel screw joints for plastic tubes

1) For ball runner blocks F.N (flange ... low) and S.N. (slimline ... low) not available

Cover plate wiper

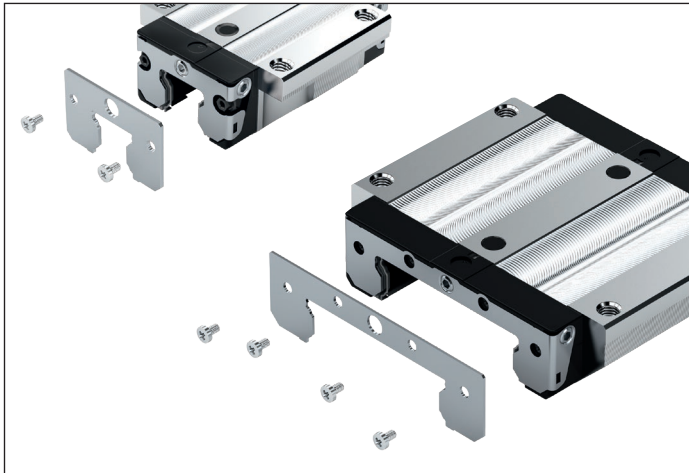

Cover plate wiper R16.0 .10 ..

- ▶ Material: Corrosion-resistant steel as per EN 10088
- ▶ Design: Bright
- ▶ Precision design with a maximum gap dimension of 0.1 to 0.3 mm

Instruction for mounting

- ▶ When combining with two-piece front seals, use seal kit: See seal kit for material numbers
- ▶ The fastening screws are included.
- ▶ When mounting, make sure that there is a uniform gap between the ball guide rail and the cover plate wiper.
- ▶ Observe the minimum screw-in depth for the end-face lube connection.
- ▶ Observe the mounting instructions.

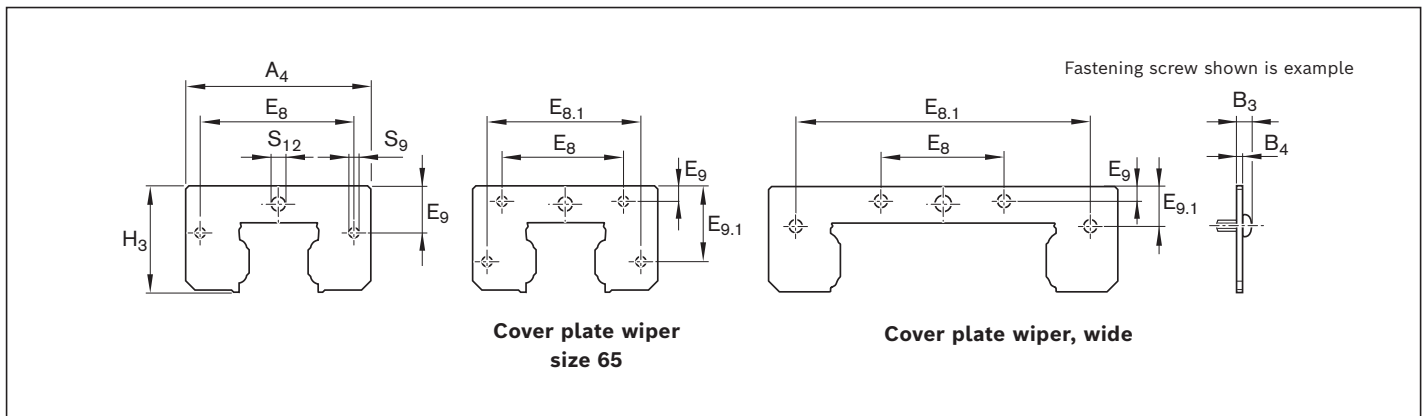

Size	Material number for ball guide rail with cover strip	Dimensions (mm)										Mass (g)
		A ₄	B ₃	B ₄	E ₈	E _{8.1}	E ₉	E _{9.1}	H ₃	S ₉	S ₁₂	
15	R1620 110 30	33.0	3.1	1.0	24.55	–	6.30	–	19.2	3.5	4.6	5
20	R1620 810 30	42.0	3.4	1.0	32.40	–	6.80	–	24.8	4.0	5.1	6
	R1620 810 35 ³⁾	41.0	3.4	1.0	30.50	–	5.10	–	22.8	4.0	4.0	5
25	R1620 210 30	47.0	3.4	1.0	38.30	–	11.00	–	29.5	4.0	7.0	8
	R1620 210 35 ³⁾	47.0	3.4	1.0	38.30	–	8.00	–	26.5	4.0	4.0	7
30	R1620 710 30	59.0	3.4	1.0	48.40	–	14.10	–	34.7	4.0	7.0	12
35	R1620 310 40 ¹⁾	69.0	3.4	1.0	58.00	–	17.00	–	40.1	4.0	7.0	16
45	R1620 410 40 ¹⁾	85.0	5.1	2.0	69.80	–	20.50	–	50.0	5.0	7.0	50
55	R1620 510 40 ¹⁾	98.0	5.7	2.0	80.00	–	21.80	–	56.4	6.0	7.0	65
65	R1620 610 40 ¹⁾	124.0	5.6	2.5	76.00	100.0	10.00	52.50	74.7	5.0	9.0	140
20/40 ⁴⁾⁵⁾	R1670 510 00 ²⁾	60.0	3.1	1.0	18.00	53.4	2.65	7.35	21.7	3.5	4.0	7
25/70 ⁴⁾	R1670 210 10 ²⁾	101.0	3.4	1.0	35.00	83.5	4.35	10.75	29.1	4.0	7.0	14
35/90 ⁴⁾	R1670 310 10 ²⁾	129.0	3.4	1.0	79.00	116.0	5.60	28.70	40.8	4.0	7.0	25

- 1) Material number for ball guide rail **without** cover strip: R1620 .10 30
- 2) Ball guide rail **without** cover strip
- 3) For ball runner blocks F.N (flange ... low) and S.N. (slimline ... low)
- 4) Wide ball rail system
- 5) Caution: Cover plate wiper, not combinable with ball guide rail R167. 8. ...!

Front seal

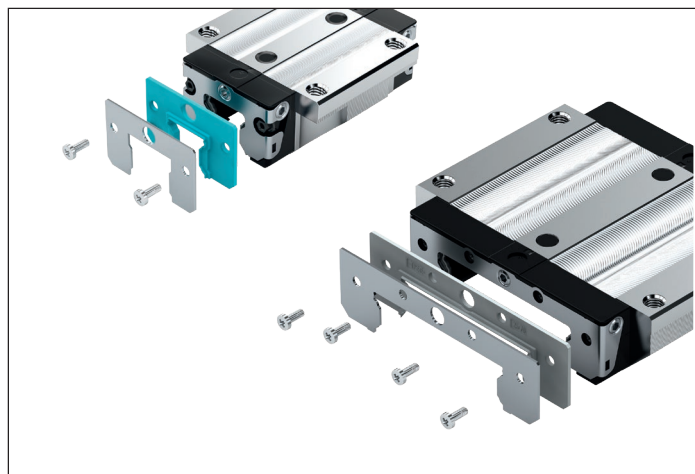

Two-piece

- ▶ Material: Corrosion-resistant steel as per DIN EN 10088 with plastic seal ring
- ▶ Design: Bright

Instruction for mounting

- ▶ The fastening screws are included.
- ▶ Observe the minimum screw-in depth for the end-face lube connection.
- ▶ Observe the mounting instructions.

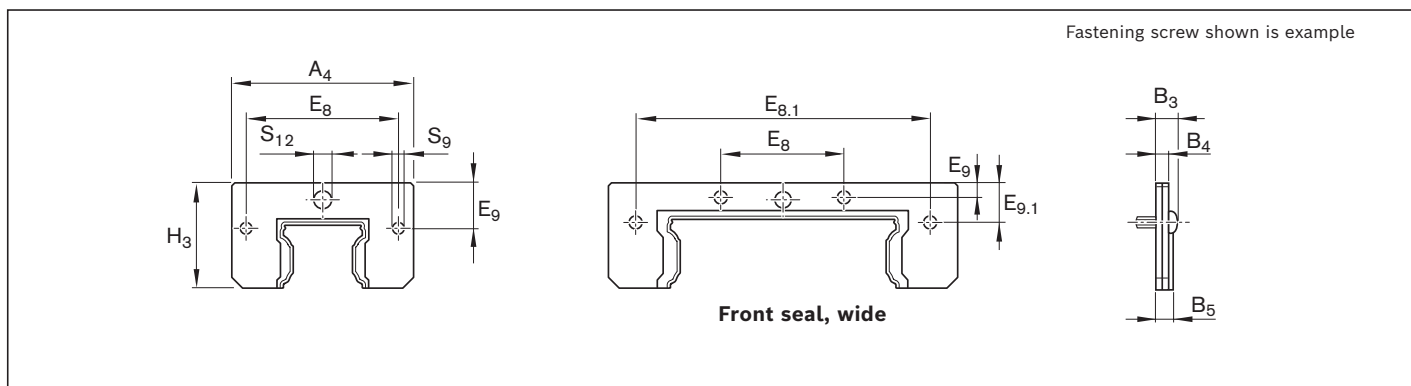

Size	Material number	Dimensions (mm)											Mass (g)
		A ₄	B ₃	B ₄	B ₅	E ₈	E _{8.1}	E ₉	E _{9.1}	H ₃	S ₉	S ₁₂	
15	R1619 121 20	32.0	4.3	2.2	3.0	24.55	-	6.30	-	19.0	3.5	4.3	6.0
20 ¹⁾	R1619 821 20	42.0	4.9	2.5	3.3	32.40	-	6.80	-	24.3	4.0	5.1	8.0
25 ¹⁾	R1619 221 30	47.0	4.9	2.5	3.3	38.30	-	11.00	-	29.0	4.0	7.0	10.0
30	R1619 721 30	59.0	5.7	3.3	4.5	48.40	-	14.10	-	34.5	4.0	7.0	18.0
35	R1619 321 30	69.0	5.7	3.3	4.5	58.00	-	17.00	-	39.5	4.0	7.0	25.0
45	R1619 421 30	85.0	7.1	4.0	5.5	69.80	-	20.50	-	49.5	5.0	7.0	55.0
55	R1619 521 30	98.0	7.7	4.0	5.5	80.00	-	21.50	-	56.0	6.0	7.0	65.0
20/40 ²⁾³⁾	R1619 522 20	60.0	4.6	2.5	3.3	18.00	53.4	2.65	7.35	21.7	3.5	4.0	7.5
25/70 ²⁾	R1619 222 20	99.0	4.9	2.5	3.3	35.00	83.5	4.30	10.70	28.6	4.0	7.3	14.5
35/90 ²⁾	R1619 322 20	128.6	5.7	3.3	4.5	79.00	116.0	5.80	28.90	41.0	4.0	7.0	40.0

1) Not for ball runner blocks F.N (flange ... low) and S.N. (slimline ... low)

2) Wide ball rail system

3) Caution: The new front seal is not combinable with existing ball guide rail R167. 8.. ...!

FKM seal

Two-piece

- ▶ Material: Corrosion-resistant steel as per DIN EN 10088 and seal made of FKM
- ▶ See Selection criteria/Seals for the area of application and resistance

Special feature

Simple mounting and dismounting on fixed ball guide rail

Instruction for mounting

- ▶ The fastening screws are included.
- ▶ Observe the minimum screw-in depth for the end-face lube connection.
- ▶ Observe the mounting instructions.

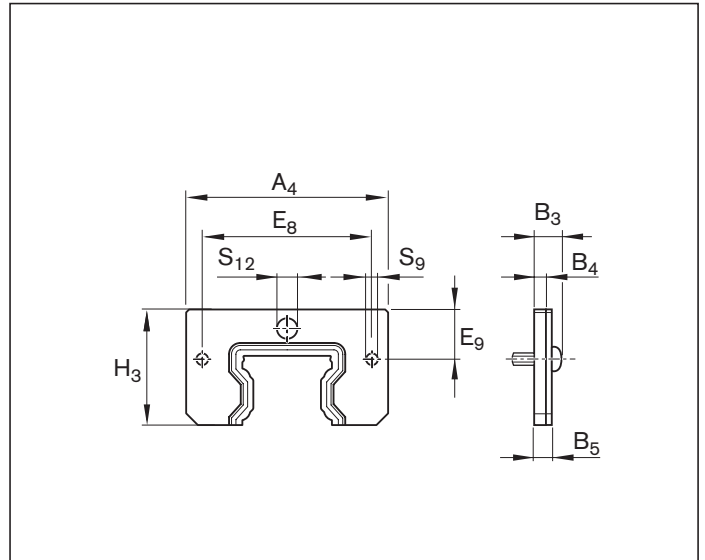

Size	Material number	Dimensions (mm)									Mass (g)
		A ₄	B ₃	B ₄	B ₅	E ₈	E ₉	H ₃	S ₉	S ₁₂	
35	R1619 320 30	69	8.4	4	6	58.0	17.0	39.5	4	7	39.0
45	R1619 420 30	85	9.1	4	6	69.8	20.5	49.5	5	7	61.0
55	R1619 520 30	98	9.7	4	6	80.0	21.8	56.4	6	7	80.5

One-piece

- ▶ Material: Corrosion-resistant steel as per DIN EN 10088 with seal made of FKM.

Instruction for mounting

- ▶ The fastening screws are included.
- ▶ Observe the minimum screw-in depth for the end-face lube connection.
- ▶ Observe the mounting instructions.

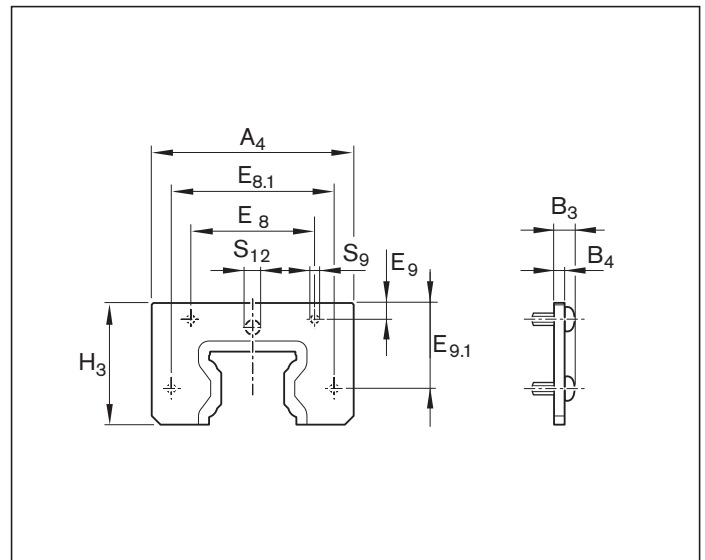

Size	Material number	Dimensions (mm)									Mass (g)	
		A ₄	B ₃	B ₄	E ₈	E _{8.1}	E ₉	E _{9.1}	H ₃	S ₉		S ₁₂
65	R1619 620 30	124	9.6	6.5	76	100	10	52.5	74.7	5	9	146

Seal kit

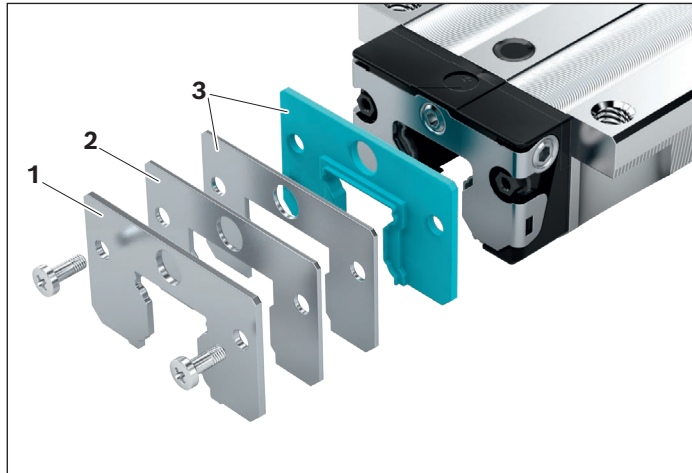

- 1 Cover plate wiper
- 2 Reinforcing plate
- 3 Two-piece front seal

Instruction for mounting

- ▶ The seal kit is recommended when combining the cover plate wiper with a two-piece front seal.
- ▶ The fastening screws are included.
- ▶ Observe the minimum screw-in depth for the end-face lube connection.
- ▶ Observe the mounting instructions.

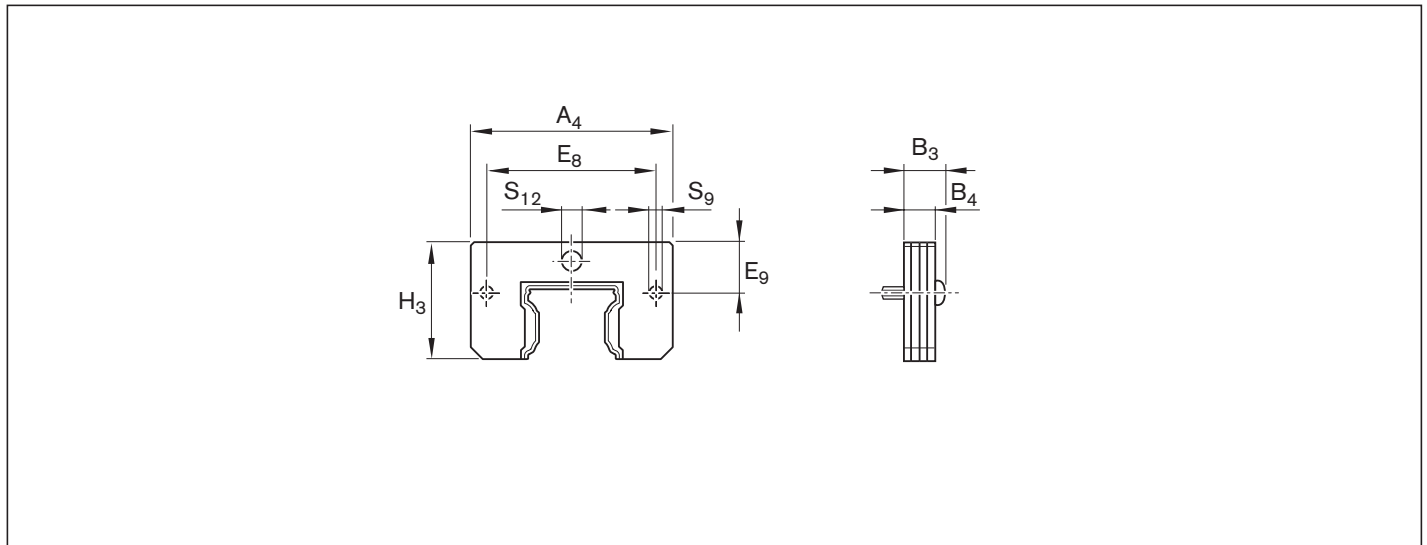

Size	Material number for ball guide rail		Dimensions (mm)								Mass (g)
	without cover strip	with cover strip	A ₄	B ₃	B ₄	E ₈	E ₉	H ₃	S ₉	S ₁₂	
15	R1619 120 50	R1619 120 50	32.0	6.3	4.2	24.55	6.30	19.0	3.5	4.3	16
20 ¹⁾	R1619 820 50	R1619 820 50	42.0	6.9	4.5	32.40	6.80	24.3	4.0	5.1	20
25 ¹⁾	R1619 220 50	R1619 220 50	47.0	6.9	4.5	38.30	11.00	29.0	4.0	7.0	26
30	R1619 720 50	R1619 720 50	59.0	8.2	5.8	48.40	14.10	34.5	4.0	7.0	42
35	R1619 320 40	R1619 320 50	69.0	8.2	5.8	58.00	17.00	39.5	4.0	7.0	57
45	R1619 420 40	R1619 420 50	85.0	11.1	8.0	69.80	20.50	49.5	5.0	7.0	155
55	R1619 520 40	R1619 520 50	98.0	11.7	8.0	80.00	21.50	56.0	6.0	7.0	195

1) Not for ball runner blocks F.N (flange ... low) and S.N. (slimline ... low)

Lubrication adapter

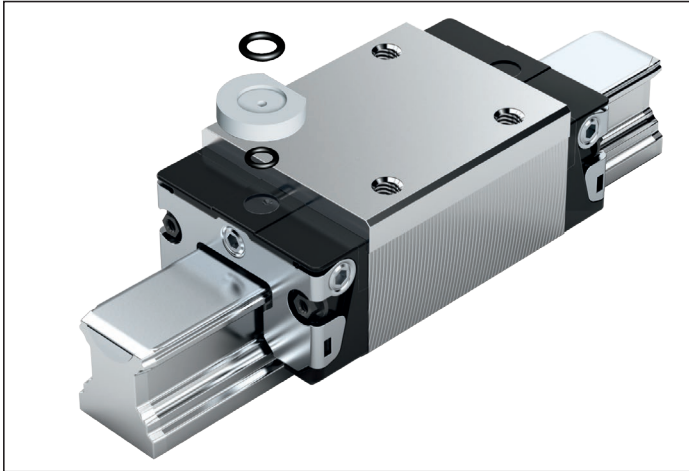

**For oil and grease lubrication from above,
only for high ball runner blocks
SNH R1621 or SLH R1624**

- ▶ Material: Plastic
- ▶ Packaging unit: 1 unit

Instruction for mounting

- ▶ O-rings are provided.
- ▶ Before mounting, use a heated pointed metal tool to open the lube port on the ball runner block (but not a drill).
- ▶ For more details, see chapter "Lubrication and maintenance".

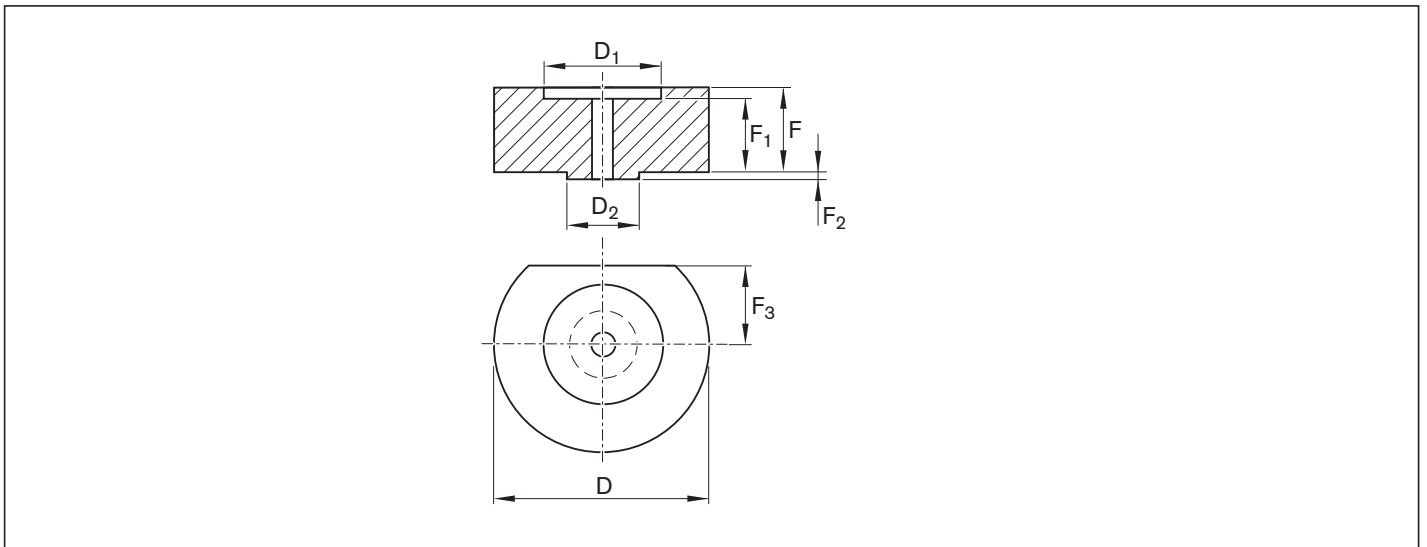

Size	Material number	Dimensions (mm)							Mass (g)
		D	D ₁	D ₂	F	F ₁	F ₂	F ₃	
15	R1621 100 05	12	6.2	3.4	3.7	3.1	0.5	3.20	0.5
25	R1621 200 05	15	7.2	4.4	3.8	3.2	0.5	5.85	0.9
30	R1621 700 05	16	7.2	4.4	2.8	2.2	0.5	6.10	0.7
35	R1621 300 05	18	7.2	4.4	6.8	6.2	0.5	6.80	2.2
45	R1621 400 05	20	7.2	4.4	9.8	9.2	0.5	8.30	4.1

Lubrication plate

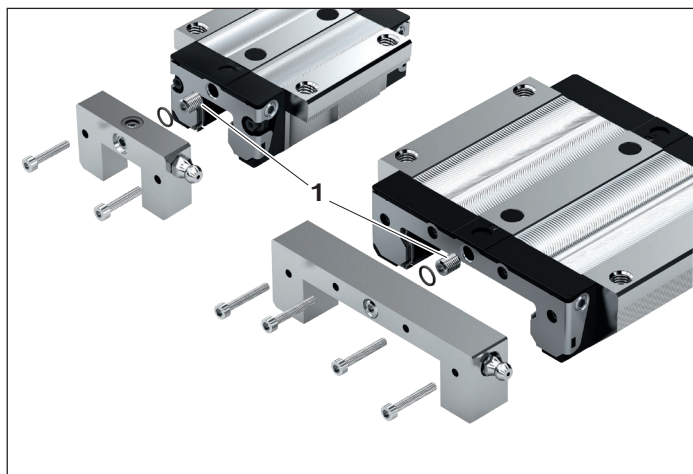

For standard lube nipples

- ▶ Material: Aluminum

Instruction for mounting

- ▶ The required mounting parts are included.
- ▶ Size 15 - 20:
A funnel-type lube nipple with a knock-in spigot is included.
- ▶ Size 25 - 65:
The lube nipple of the ball runner block can be used.
- ▶ Observe the mounting instructions.

⚠ The enclosed lube pin (1) must be mounted between the lubrication plate and the ball runner block!
(It contains a lube port.)

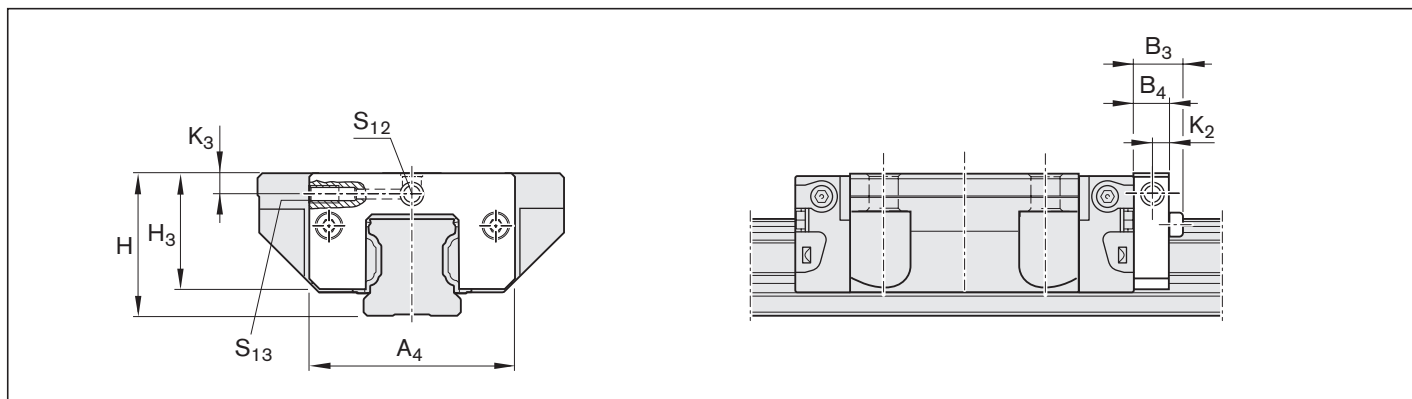

Size	Material number	Dimensions (mm)									Mass (g)
		A ₄	B ₃	B ₄	H	H ₃ ²⁾	K ₂	K ₃ ²⁾	S ₁₂	S ₁₃	
15	R1620 111 20	32	13.1	11	24 28 ³⁾	19.0	5.5	3.4 7.4 ³⁾	M3	Ø3	15
20 ¹⁾	R1620 811 20	42	15.0	12	30	24.8	6.0	3.5	M3	Ø3	25
25 ¹⁾	R1620 211 20	47	15.0	12	36 40 ³⁾	28.3	6.0	6.0 10.0 ³⁾	M6	M6	30
30	R1620 711 20	59	15.0	12	42 45 ³⁾	33.8	6.0	8.0 11.0 ³⁾	M6	M6	45
35	R1620 311 20	69	15.0	12	48 55 ³⁾	39.1	6.0	8.0 15.0 ³⁾	M6	M6	60
45	R1620 411 20	85	16.0	12	60 70 ³⁾	48.5	6.0	8.0 18.0 ³⁾	M6	M6	85
55	R1620 511 20	98	17.0	12	70 80 ³⁾	56.0	6.0	9.0 19.0 ³⁾	M6	M6	115
65	R1620 611 20	124	18.0	14	90	75.7	7.0	18.0	M8x1	M8x1	250

1) Not for ball runner blocks F.N (flange ... low) and S.N. (slimline ... low)
 2) Based on the mounting face of the ball runner block
 3) For ball runner blocks S.H (slimline ... high)

Lubrication plate G 1/8

For lube nipples G 1/8

► Material: Aluminum

Instruction for mounting

- The required mounting parts are included.
- Ball runner block S.. (slimline) Size 25: Observe the side projection of the lubrication plate.
- Observe the mounting instructions.

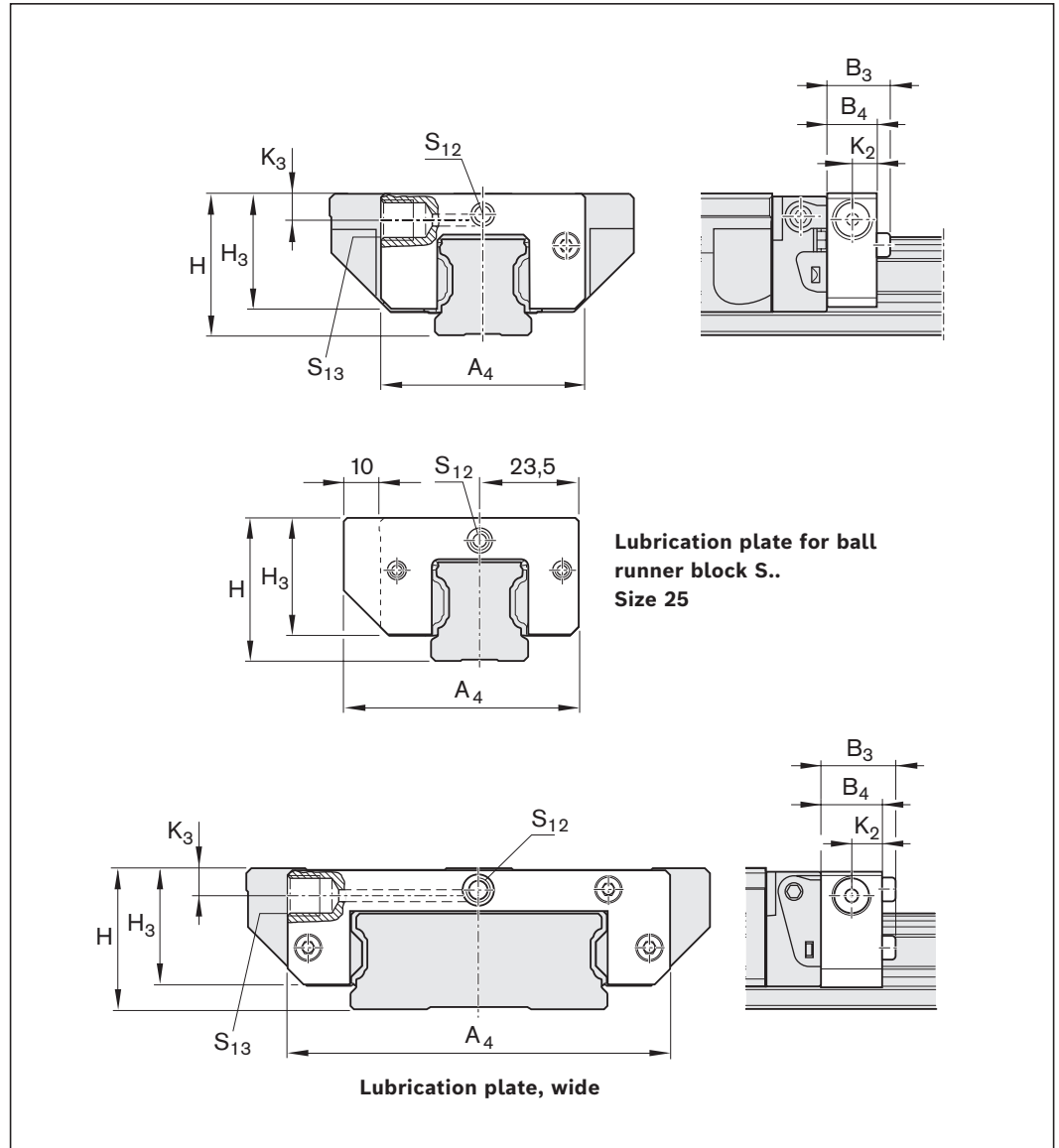

Size	Material number	Dimensions (mm)									Mass (g)
		A ₄	B ₃	B ₄	H	H ₃ ²⁾	K ₂	K ₃ ²⁾	S ₁₂	S ₁₃	
25 ¹⁾	R1620 211 30	57	19.0	16	36 40 ³⁾	28.3	8	7.0 11.0 ³⁾	M6	G 1/8x8	40
30	R1620 711 30	59	19.0	16	42 45 ³⁾	33.8	8	7.0 10.0 ³⁾	M6	G 1/8x8	59
35	R1620 311 30	69	19.0	16	48 55 ³⁾	39.1	8	8.0 15.0 ³⁾	M6	G 1/8x8	79
45	R1620 411 30	85	20.0	16	60 70 ³⁾	48.5	8	8.0 18.0 ³⁾	M6	G 1/8x8	112
55	R1620 511 30	98	21.0	16	70 80 ³⁾	56.0	8	9.0 19.0 ³⁾	M6	G 1/8x8	152
65	R1620 611 30	124	20.0	16	90	75.7	8	18.0	M6	G 1/8x8	285
25/70 ⁴⁾	R1670 211 40	99	19.0	16	35	29.6	8	8.4	M6	G 1/8x8	65
35/90 ⁴⁾	R1670 311 30	129	19.0	16	50	42.0	8	9.5	M6	G 1/8x8	120

1) Not for ball runner blocks F.N (flange ... low) and S.N. (slimline ... low)

2) Based on the mounting face of the ball runner block

3) For ball runner blocks S.H (slimline ... high)

4) Wide ball rail system

Transport lock



Transport lock for ball runner blocks

For transporting and as a mounting device

► Material: Plastic

Size	Material numbers	Mass (g)
15	R1653 101 89	2
20	R1653 801 89	3
25	R1653 202 89	4
30	R1653 702 89	10
35	R1653 302 89	10
45	R1653 402 89	20
55	R1653 502 89	31
65	R1653 602 89	58
20/40	R1671 505 89	7
25/70	R1671 201 89	13
35/90	R1671 301 89	33

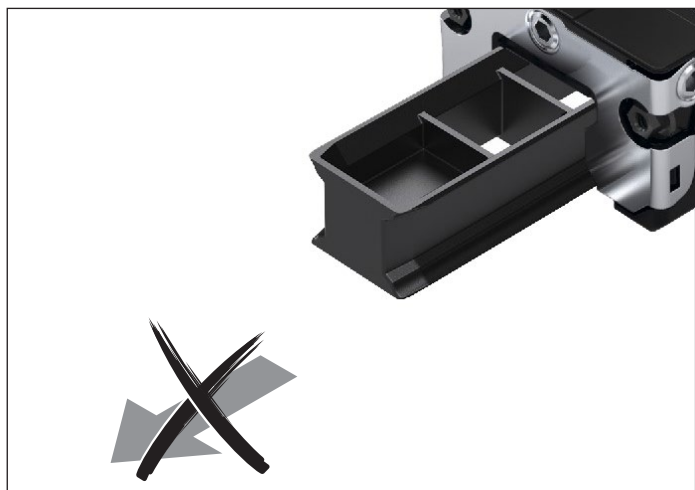

Notes

The ball runner block is slid from the transport lock onto the rail.

See the chapter "Instruction for mounting".

⚠ The transport lock must remain in the ball runner block until it slides onto the ball guide rail! Otherwise it is possible to lose the balls!

Front lube units

For travel up to 25 000 km without relubrication

Advantages for mounting and operation

- ▶ For a travel distance of up to 25,000 km without re-lubrication
- ▶ Ball runner block only requires initial lubrication with grease
- ▶ Front lube units on both sides of the ball runner block
- ▶ Low lubricant loss
- ▶ Reduced oil consumption
- ▶ No lubrication lines
- ▶ Max. operating temperature 60°C
- ▶ Front lube unit can be refilled using the lube nipple on the end-face or at the side.
- ▶ Lube connection on the end-face of the front lube unit is suitable for lubricating the ball runner block with grease.

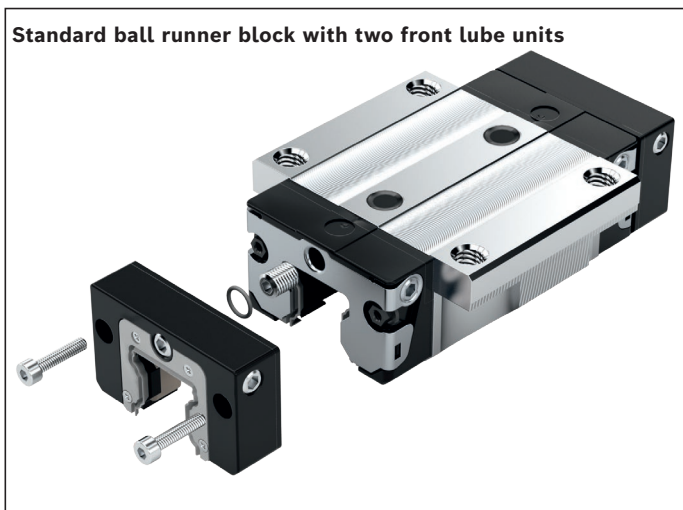

Size	Possible travel distance s with front lube units (km)
15	15000
20*)	15000
25*)	25000
30	25000
35	25000
45	25000
55	1500
65	1000

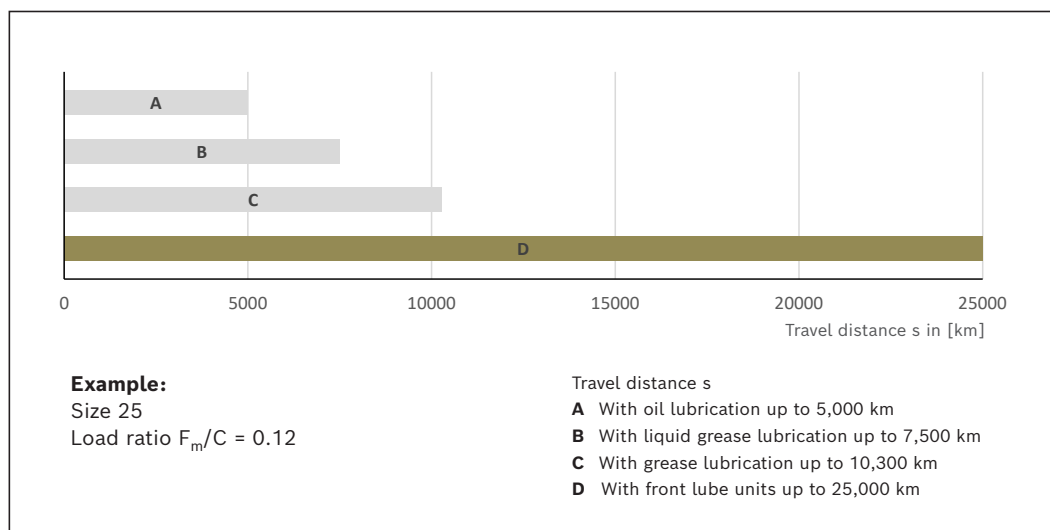

Material numbers, dimension drawing, dimensions and technical data see following page.

*) Low ball runner blocks of type FNN, SNN, FKN and SKN have shorter travel distances. See diagram 1 "Load-dependent relubrication intervals for ball runner blocks with front lube units".

Lubricant distribution

Due to the special structural design of the lubricant distribution, lubrication occurs primarily where it is needed: directly on the raceways and the top surfaces of the ball guide rails.

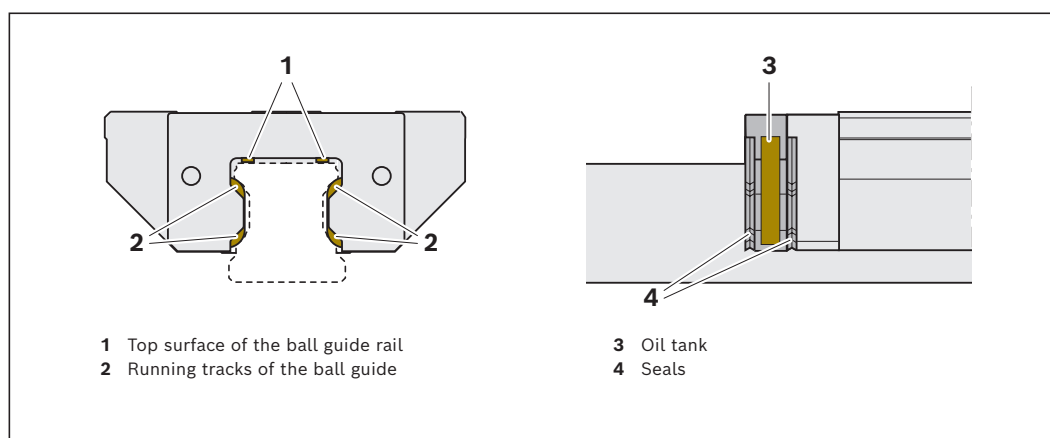

Front lube unit R1619 .2. 00

Material:
Special plastic

The front lube units R1619 .2. 00 are supplied ready-filled with oil (Mobil SHC 639) and can be mounted after basic lubrication of the ball runner blocks.

Front lube unit R1619 .2. 10

Material:
Special plastic

The front lube units R1619 .2. 10 are not filled at the factory.

Recommended lubricant oil for initial filling:

- ▶ Mobil SHC 639 (viscosity 1000 mm²/s at 40 °C)

An initial lubrication of the ball runner blocks **with grease lubricant** is required before mounting the front lube units! **See chapter "Lubrication".**

If other types of lubricant oil are used, please consider the compatibility of the lubricants and the travel distance!

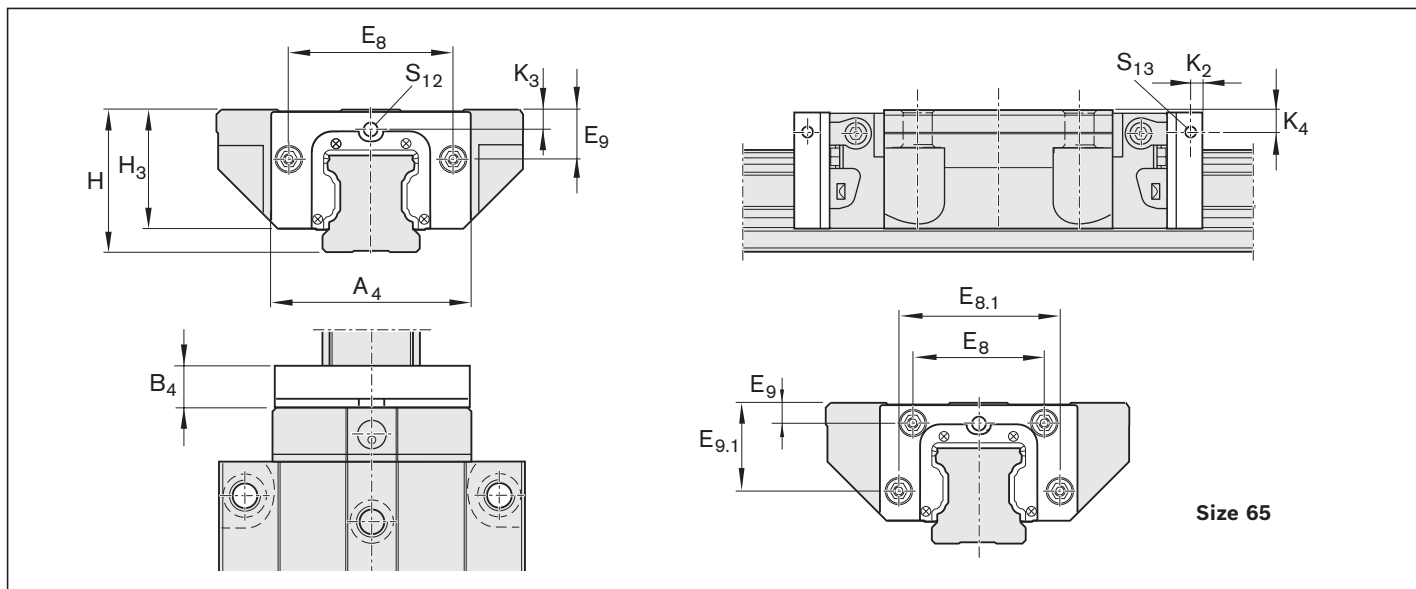

Size	Material number	Dimensions (mm)											Oil (cm ³)	Mass (g)	
		A ₄	B ₄	E ₈	E _{8.1}	E ₉ ²⁾	E _{9.1} ²⁾	H	H ₃ ²⁾	K ₂	K ₃ ²⁾ /K ₄ ²⁾	S ₁₂			S ₁₃
15	R1619 125 00	31.8	11.5	24.55	-	6.70	-	24	19.40	5	3.35	M3	M3	1.00	15
						10.70 ³⁾		28 ³⁾	23.40 ³⁾		7.35 ³⁾				
20	R1619 825 00	43.0	12.5	32.50	-	7.30	-	30	24.90	5	3.70	M3	M3	2.20	20
	R1619 826 00 ¹⁾	41.0	12.5	30.50	-	5.60	-	28	22.90	-	3.10	-	M3	1.80	20
25	R1619 225 00	47.0	13.0	38.30	-	11.50	-	36	29.30	5	5.50	M6	M6	2.60	25
						15.50 ³⁾		40 ³⁾	33.30 ³⁾		9.50 ³⁾				
	R1619 226 00 ¹⁾	47.0	13.0	38.30	-	8.50	-	33	26.30	5	4.10	M3	M3	2.50	25
30	R1619 725 00	58.8	14.5	48.40	-	14.60	-	42	35.05	6	6.05	M6	M6	3.85	35
						17.60 ³⁾		45 ³⁾	38.05 ³⁾		9.05 ³⁾				
35	R1619 325 00	69.0	16.0	58.00	-	17.35	-	48	39.85	6	6.90	M6	M6	5.70	50
						24.35 ³⁾		55 ³⁾	46.85 ³⁾		13.90 ³⁾				
45	R1619 425 00	84.0	17.0	69.80	-	20.90	-	60	49.80	7	8.20	M6	M6	9.60	70
						30.90 ³⁾		70 ³⁾	59.80 ³⁾		18.20 ³⁾				
55	R1619 525 00	99.0	18.0	80.00	-	22.30	-	70	57.05	8	8.90	M6	M6	14.50	90
						32.30 ³⁾		80 ³⁾	67.05 ³⁾		18.90 ³⁾				
65	R1619 625 00	124.2	19.0	76.00	100	11.00	53.5	90	75.70	8	16.00	M8	M8	30.00	130

- 1) For ball runner blocks F.N (flange ... low) and S.N. (Slimline ... low)
- 2) Based on the mounting face of the ball runner block
- 3) For ball runner blocks S.H (Slimline ... high)

Front lube units

Initial filling of a front lube unit without oil

- ▶ Remove the set screw from the lube port (fig. 1, item 1) and keep for later use.
- ▶ Screw in lube nipple (2).
- ▶ Lie the front lube unit (3) down flat, fill with quantity of oil as per table 1, and leave it to lie for around 36 hours.
- ▶ Check whether the lube insert is completely soaked with oil. If necessary, add oil.
- ▶ Remove lube nipple.
- ▶ Screw in the set screw

- ▶ For size 20 low profile: Stand the front lube units in 10 mm of oil for approx. 36 hours (see fig. 2).

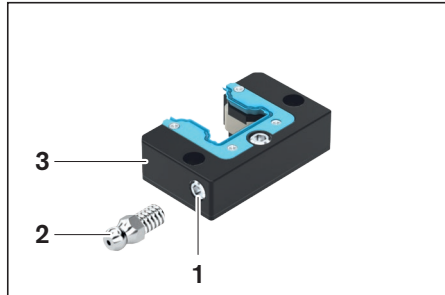

Figure 1

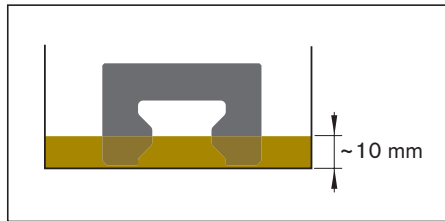

Figure 2

Size	Oil quantity for initial filling of a front lube unit without oil (cm ³)
15	0.90
20	2.00
25	2.40
30	3.85
35	5.70
45	9.60
55	14.50
65	30.00

Table 1

Relubrication of front lube units

If the relubrication interval according to diagram 1 has been reached, relubricate the amount stated in table 1.

- ▶ The units can be relubricated through the lube connection at the side.
- ▶ The front lube unit size 20 low is **not** refillable via the lube connection (see figure 2).

Note

Rexroth recommends replacing the front lube units every 3 years at the latest and re-lubricating the ball runner block before mounting the new front lube unit.

Relubrication of the ball runner blocks

In clean operating environments, the ball runner blocks can be relubricated with grease (Dynalub 510) at the end face. Relubrication of the ball runner blocks **with grease lubricant** see the "Lubrication" chapter

⚠ If other lubricants are used, this may lead to a reduction in the lubrication intervals, performance losses in short stroke applications and the load capacities. Possible chemical interactions between the plastic materials, lubricants and preservative agents must also be taken into account.

The recommended lubrication intervals depend on environmental factors, load and load type.

Examples of environmental factors include swarf, mineral abrasion (or similar), solvent and temperature.

Examples of loads and stress types are oscillations, shocks and tilting.

⚠ The conditions of use are unknown to the manufacturer. Only the user's own trials or accurate monitoring can yield safety across lubrication intervals.

⚠ Do not use water-based coolant/lubricant on the ball guide rails and ball runner block!

Load-dependent relubrication intervals for ball runner blocks with front lube units

This applies to the following conditions:

- ▶ Ball runner block lubricants:
Dynalub 510 (grease NLGI 2),
alternatively Castrol Tribol GR 100-2 PD
or Elkalube GLS 135/N2
- ▶ Front lube units lubricant:
Mobil SHC 639 (synthetic oil)
- ▶ Maximum speed: $v_{max} = 2$ m/s
- ▶ No media pressurization
- ▶ Standard seals (SS)
- ▶ Ambient temperature: $T = 10 - 40$ °C

Key

- C = Dynamic load capacity (N)
- F_m = Dynamically equivalent load on bearing (N)
- F_m/C = Load ratio (-)
- s = Lubrication interval as travel distance (km)

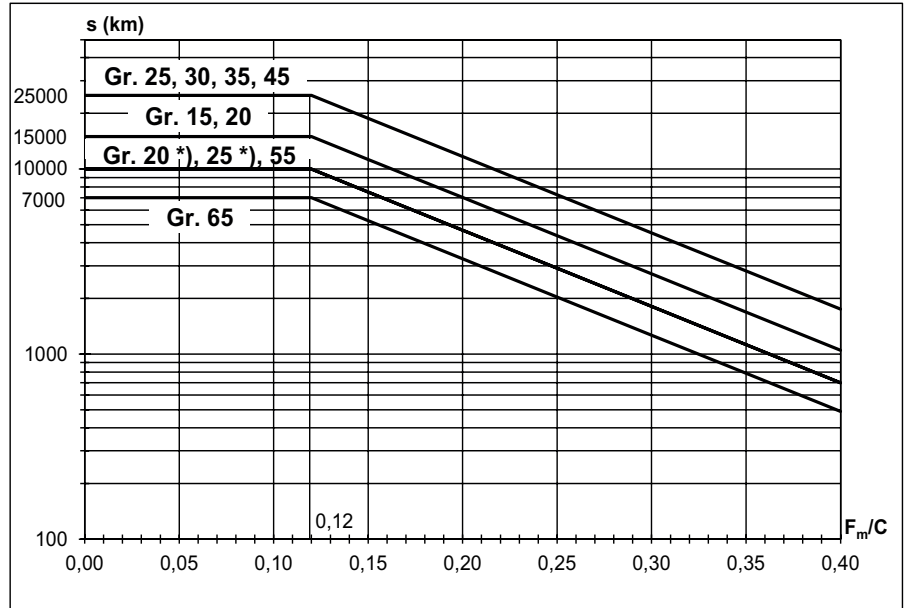

Diagram 1

(-) *)ball runner blocks F.N (flange ... low) and S.N. (slimline ... low)

Mounting of front lube units

Instruction for mounting

The required mounting accessories (coated screws, seals and lube nipples) are supplied along with the units.

Mount a front lube unit on both sides of the ball runner block (fig. 3, pos. 3)!

Do not remove the ball runner block from the ball guide rail!

Ball runner blocks up to size 45 (fig. 3a):

The enclosed lube pin (2) must be mounted between the lubrication plate and the ball runner block!

(It contains a lube port.)

- ▶ Remove the set screws (1).
- ▶ Screw in the lube pin (2).
- ▶ Slide on the front lube units (3).
- ▶ Insert o-rings (5) between the ball runner block and front lube units.
- ▶ Tighten screws (4) to tightening torque M_A (see table 2).

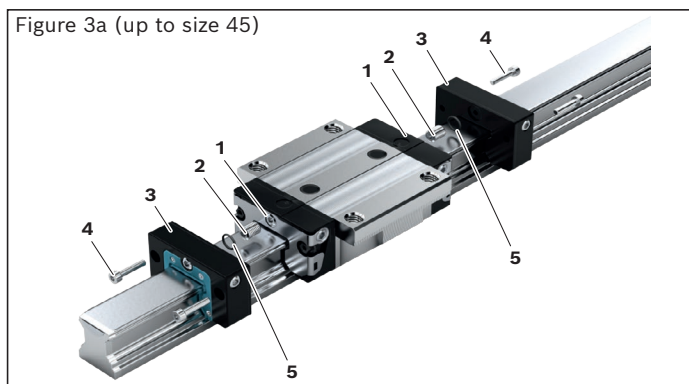

Ball runner blocks from size 55 (fig. 3b):

- ▶ Slide on the front lube units (3).
- ▶ Remove the set screws (1) and insert the o-rings (5) between the ball runner block and front lube units.
- ▶ Tighten screws (4) to tightening torque M_A (see table 2).

Size	 Pos. 4	Tightening torque M_A (Nm)
15	M2.5 x 12	0.3
20	M3 x 14	0.6
25	M3 x 14	0.6
30	M3 x 14	1.2
35	M3 x 16	1.2
45	M4 x 18	1.6
55	M5 x 18	2.0
65	M4 x 20	1.6

Table 2



Bellows

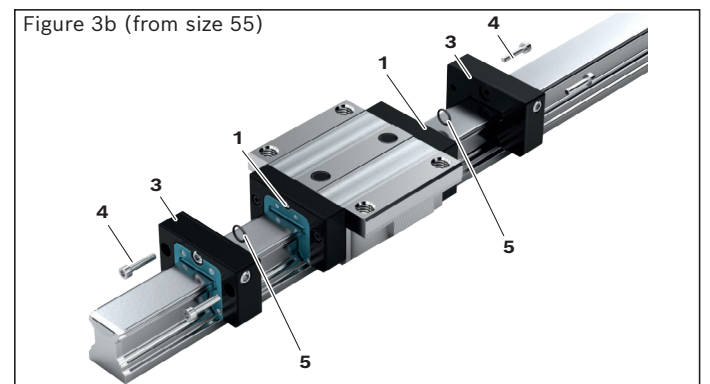
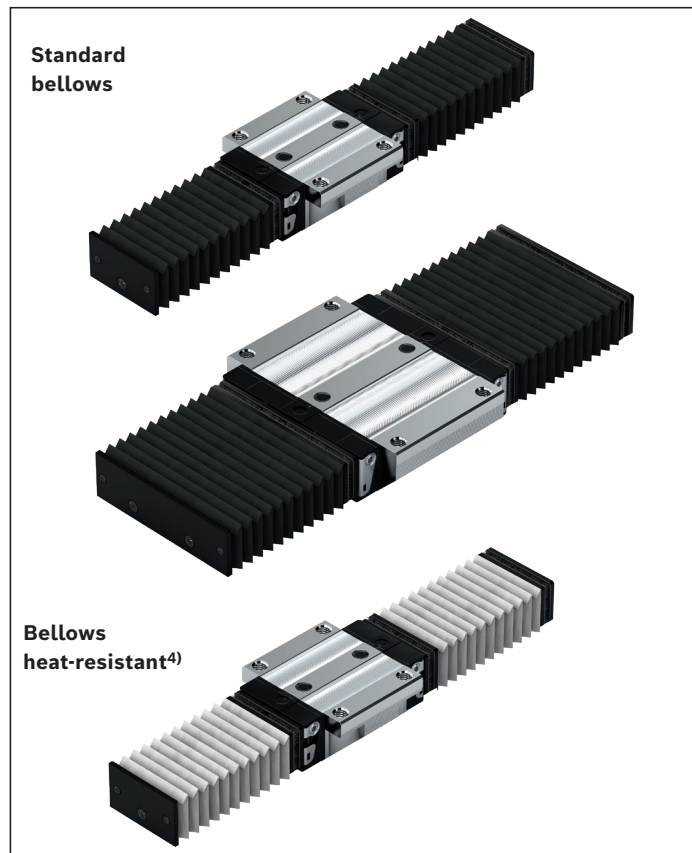

Standard bellows

R1620 .0. 00

- ▶ Material: Polyurethane-coated polyester fabric
- ▶ Aluminum lubrication plate

Heat-resistant bellows⁴⁾

R1620 .5. 00

- ▶ Material: Nomex fabric, metalized

Temperature stability

- ▶ Non combustible, non flammable
- ▶ Resistant to sparks, welding spatter and hot chips
- ▶ The protective metal coating can withstand peak temperatures of up to 200 °C
- ▶ Operating temperature for the total bellows max. 80 °C

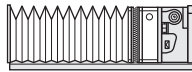
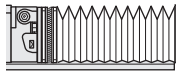
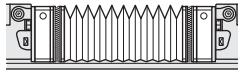
Size	Material number, fold count		
	 Type 1: With lubrication plate ¹⁾ and end plate Type 6: With VSE ²⁾ and end plate	 Type 2: With fastening frame and end plate	 Type 3: With 2 lubrication plates ¹⁾ Type 7: With 2 VSE ²⁾
	Material number, fold count		
	Standard bellows		
15	R1620 10. 00, ...	R1620 102 00, ...	R1620 10. 00, ...
20	R1620 80. 00, ...	R1620 802 00, ...	R1620 80. 00, ...
25	R1620 20. 00, ...	R1620 202 00, ...	R1620 20. 00, ...
30	R1620 70. 00, ...	R1620 702 00, ...	R1620 70. 00, ...
35	R1620 30. 00, ...	R1620 302 00, ...	R1620 30. 00, ...
45	R1620 40. 00, ...	R1620 402 00, ...	R1620 40. 00, ...
55	R1620 50. 00, ...	R1620 502 00, ...	R1620 50. 00, ...
65	R1620 60. 00, ...	R1620 602 00, ...	R1620 60. 00, ...
20/40 ³⁾	–	R1670 502 00, ...	–
25/70 ³⁾	–	R1670 202 00, ...	–
35/90 ³⁾	–	R1670 302 00, ...	–
	Heat-resistant bellows⁴⁾		
25	R1620 25. 00, ...	R1620 252 00, ...	R1620 25. 00, ...
30	R1620 75. 00, ...	R1620 752 00, ...	R1620 75. 00, ...
35	R1620 35. 00, ...	R1620 352 00, ...	R1620 35. 00, ...
45	R1620 45. 00, ...	R1620 452 00, ...	R1620 45. 00, ...
55	R1620 55. 00, ...	R1620 552 00, ...	R1620 55. 00, ...
65	R1620 65. 00, ...	R1620 652 00, ...	R1620 65. 00, ...

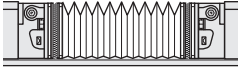
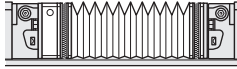
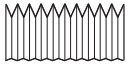
Size	Material number, fold count		
	 Type 4: With 2 fastening frames	 Type 5: With lubrication plate ¹⁾ and fastening frame Type 8: With VSE ²⁾ and fastening frame	 Type 9: Loose bellows (spare part)
Material number, fold count			
Standard bellows			
15	R1620 104 00, ...	R1620 10. 00, ...	R1600 109 00, ...
20	R1620 804 00, ...	R1620 80. 00, ...	R1600 809 00, ...
25	R1620 204 00, ...	R1620 20. 00, ...	R1600 209 00, ...
30	R1620 704 00, ...	R1620 70. 00, ...	R1600 709 00, ...
35	R1620 304 00, ...	R1620 30. 00, ...	R1600 309 00, ...
45	R1620 404 00, ...	R1620 40. 00, ...	R1600 409 00, ...
55	R1620 504 00, ...	R1620 50. 00, ...	R1600 509 00, ...
65	R1620 604 00, ...	R1620 60. 00, ...	R1600 609 00, ...
20/40 ³⁾	R1670 504 00, ...	-	R1670 509 00, ...
25/70 ³⁾	R1670 204 00, ...	-	R1670 209 00, ...
35/90 ³⁾	R1670 304 00, ...	-	R1670 309 00, ...
Heat-resistant bellows ⁴⁾			
25	R1620 254 00, ...	R1620 25. 00, ...	R1600 259 00, ...
30	R1620 754 00, ...	R1620 75. 00, ...	R1600 759 00, ...
35	R1620 354 00, ...	R1620 35. 00, ...	R1600 359 00, ...
45	R1620 454 00, ...	R1620 45. 00, ...	R1600 459 00, ...
55	R1620 554 00, ...	R1620 55. 00, ...	R1600 559 00, ...
65	R1620 654 00, ...	R1620 65. 00, ...	R1600 659 00, ...

Weights on request

- 1) No lubrication plate necessary for ball runner blocks with side lube ports
- 2) VSE = Front lube unit
- 3) Wide ball rail system
- 4) Note overall height (see dimension drawing/dimensions of heat-resistant bellows)

Ordering example:

- ▶ Bellows
- ▶ Size 35
- ▶ Standard
- ▶ Type 6 with VSE and end plate
- ▶ Number of folds: 36

Example: R1620 3 0 6 00, 36 Folding

Standard = 0
Heat-resistant = 5
Type 1 - 9

Bellows

Instruction for mounting

- ▶ The bellows are pre-mounted.
- ▶ The fastening screws are included.
- ▶ Bellows with lubrication plate (type 1, 3 - 5) sizes 15 - 20:
A funnel-type lube nipple with a knock-in spigot is included.
Sizes 25 - 65 and wide:
The lube nipple of the ball runner block can be used.

- ▶ For type 1 and type 2, an M4x10 thread with 2 x 45° countersink must be placed in the end face of the ball guide rail SNS in each case.
For ball guide rail BNS: Tap two threads at each end face.

- ▶ Observe the mounting instructions

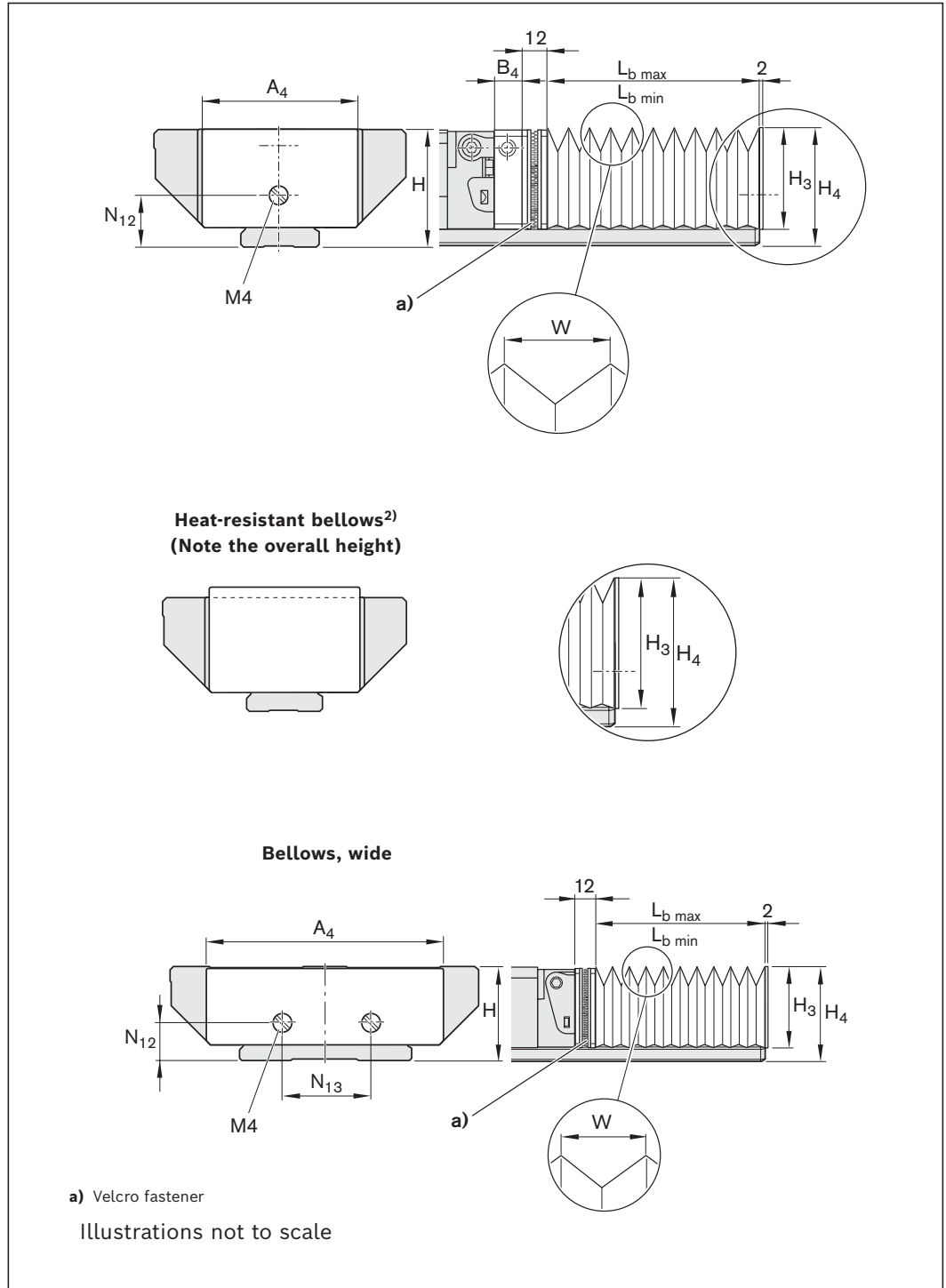

Standard bellows

Size	Dimensions (mm)								Factor U
	A ₄	B ₄	H	H ₃	H ₄	N ₁₂	N ₁₃	W	
15	45	11	24	26.5	31.5	11.0	-	21.0	1.25
20	42	12	30	24.0	29.2	13.0	-	10.5	1.56
25	45	12	36	28.5	35.0	15.0	-	14.0	1.39
30	55	12	42	34.0	41.0	18.0	-	17.5	1.30
35	64	12	48	39.0	47.0	22.0	-	21.0	1.32
45	83	12	60	49.0	59.0	30.0	-	28.0	1.23
55	96	12	70	56.0	69.0	30.0	-	31.5	1.20
65	120	14	90	75.0	89.0	40.0	-	43.75	1.14
20/40 ¹⁾	73	-	27	31.0	35.0	11.5	-	21.0	1.25
25/70 ¹⁾	101	-	35	29.0	35.0	14.0	26	14.0	1.39
35/90 ¹⁾	128	-	50	42.0	49.0	21.5	40	21.0	1.32

Heat-resistant bellows²⁾

Size	Dimensions (mm)								Factor U
	A ₄	B ₄	H	H ₃	H ₄	N ₁₂	N ₁₃	W	
25	62	12	36	39.0	44.5	15	-	28.0	1.43
30	67	12	42	42.0	47.5	18	-	28.0	1.43
35	74	12	48	47.0	54.0	22	-	31.5	1.38
45	88	12	60	55.0	64.0	30	-	35.0	1.33
55	102	12	70	63.0	75.0	30	-	40.25	1.28
65	134	14	90	86.0	99.0	40	-	57.75	1.19

- 1) Wide ball rail system
- 2) Observe the overall height (dimension H₄ compared with dimension H)

Calculation

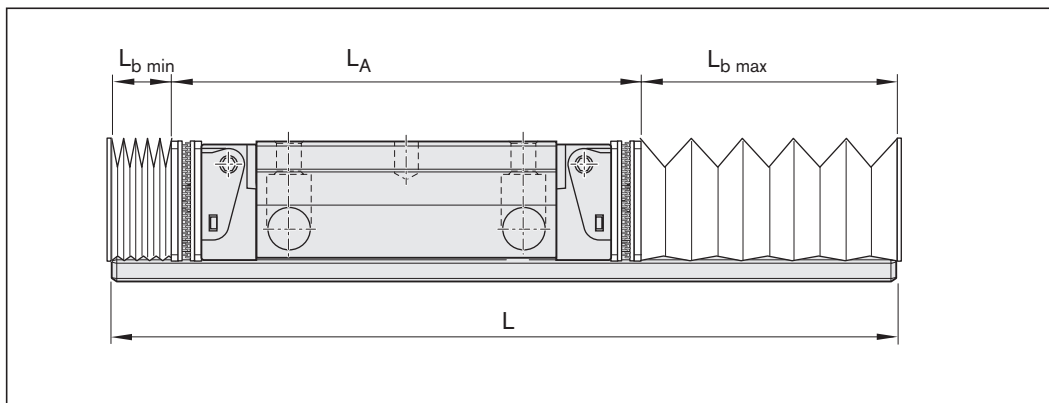

Ball guide rail length

$$L = s_{\max} \cdot U + L_A + 30$$

$$L_A = B + 2 \cdot 12 + B_4$$

$$s_{\max} = \frac{L - L_A - 30}{U}$$

- L = Ball guide rail length (mm)
- s_{max} = Maximum travel range (mm)
- U = Calculation factor (-)
- L_A = Length of ball runner block with attachments (mm)
- B = Ball runner block length (mm)
(see chapter "Ball runner blocks")
- B₄ = Front unit width (mm)
(see chapter "Accessories for ball runner blocks")

Bellows

$$L_{b\min} = 1/2 (L - s_{\max} - L_A)$$

$$L_{b\max} = L_{b\min} + s_{\max}$$

$$n = \frac{L_{b\max}}{W} + 2$$

- L_{bmin} = Bellows, contracted (mm)
- L_{bmax} = Bellows, maximum elongated (mm)
- n = Number of folds (-)
- W = Maximum bellows extension (mm)

- 1) At predetermined travel
- 2) With limited installation space

Lube nipple, lube fittings, extensions

Funnel-type lube nipple according to DIN 3405

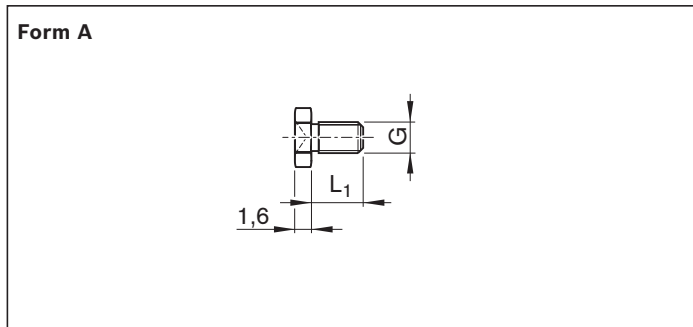

Material number	Dimensions (mm)		Mass (g)
	G	L ₁	
R3417 029 09	M3	5	0.3
R3417 032 09 ¹⁾			

1) Lube nipple Resist NR II made of corrosion-resistant steel according to DIN EN 10088

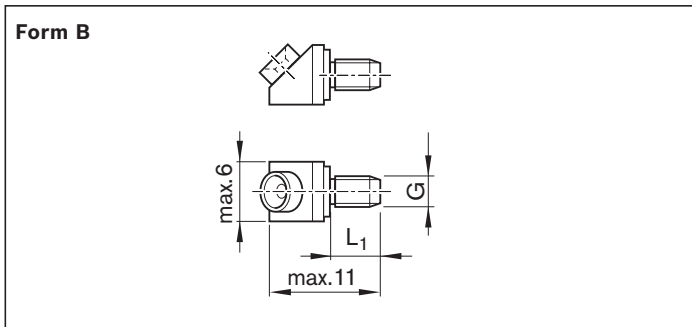

Material number	Dimensions (mm)		Mass (g)
	G	L ₁	
R3417 004 09	M3	5	1.5

Ball-type lube nipple

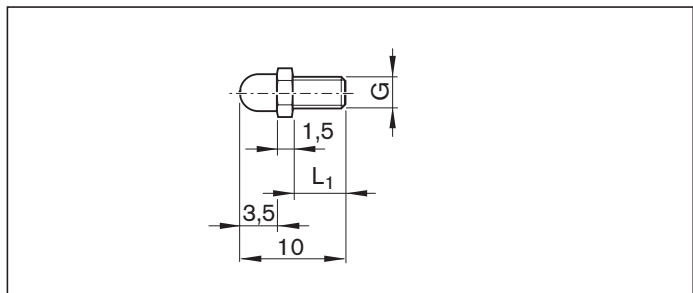

Material number	Dimensions (mm)		Mass (g)
	G	L ₁	
R3417 005 01 ¹⁾	M3	5	0.5

1) Material: Brass

Hydraulic-type lube nipple according to DIN 71412

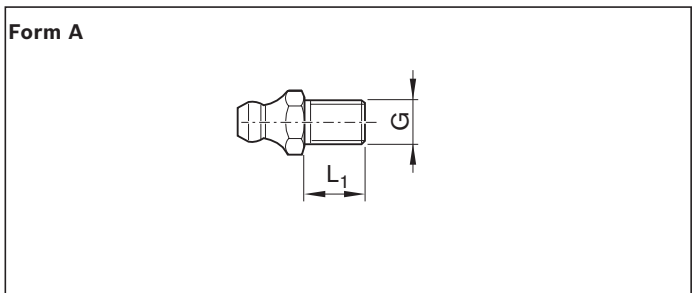

Material number	Dimensions (mm)		Mass (g)
	G	L ₁	
R3417 008 02	M6	8	2.6
R3417 016 02 ¹⁾			

1) Lube nipple Resist NR II made of corrosion-resistant steel according to DIN EN 10088

Hydraulic-type lube nipple according to DIN 71412

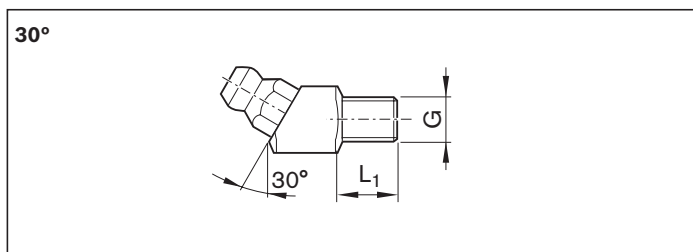

Material number	Dimensions (mm)		Mass (g)
	G	L ₁	
R3417 023 02	M6	8	7.4

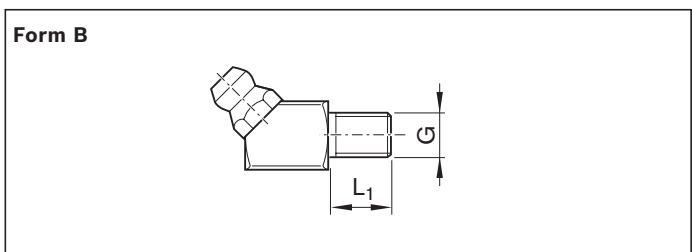

Material number	Dimensions (mm)		Mass (g)
	G	L ₁	
R3417 007 02	M6	8	7.4
R3417 006 02	M8x1	8	8.0

Lube fittings

Plastic tube for lube connection

Plastic tube Ø 3 mm



Material number	Dimensions			Mass (kg)
	External Ø (mm)	Internal Ø (mm)	Length (m)	
R3499 287 00	3	1.7	50	0.4

O-rings

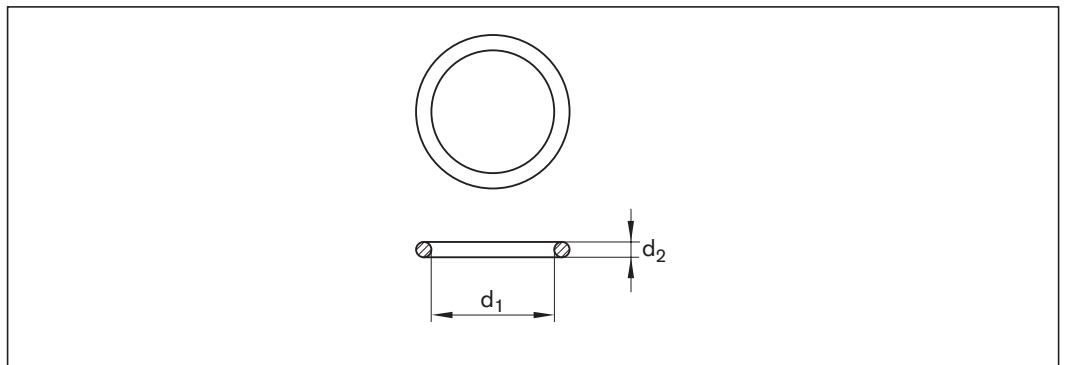

Material number	d ₁ x d ₂ (mm)	Mass
R3411 130 01	4 x 1.0	
R3411 131 01	5 x 1.0	
R3411 003 01	6 x 1.5	0.03

Nozzle pipe

for manual grease guns.

For the lubrication of funnel-type and ball-type lube nipples for ball runner blocks BSHP.

Scope of delivery:

- 1 x nozzle pipe
- 1 x interchangeable insert A for funnel-type lube nipple
- 1 x interchangeable insert B for ball-type lube nipple

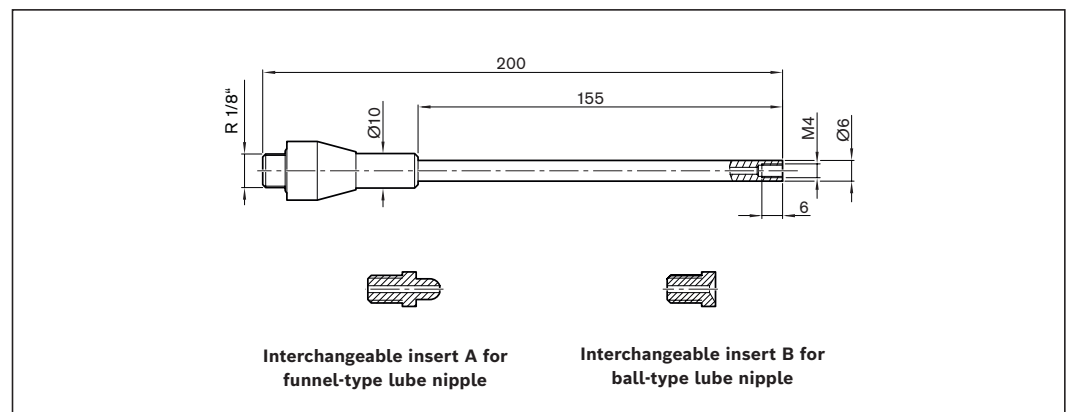

Material number	Dimensions (mm)	Mass (g)
R3455 031 06	L 200	158

Lube nipple, lube fittings, extensions

Lube fittings

Reducers

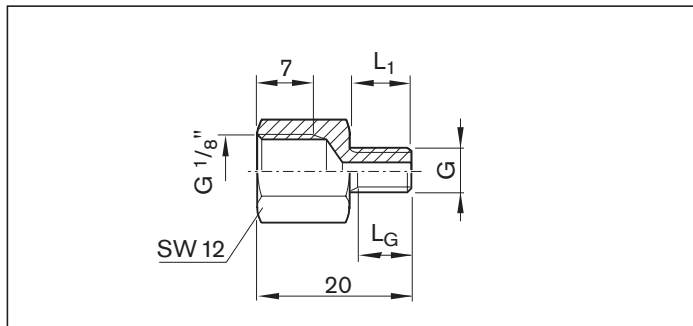

Material number	Dimensions (mm)			Mass (g)
	G	L ₁	L _G	
R3455 030 34	M6	8	6.5	7.5

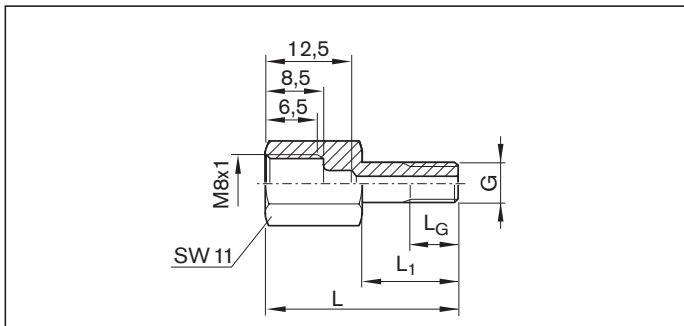

Material number	Dimensions (mm)				Mass (g)
	G	L	L ₁	L _G	
R3455 030 53	M8x1	28.5	14.5	8	10

Extensions

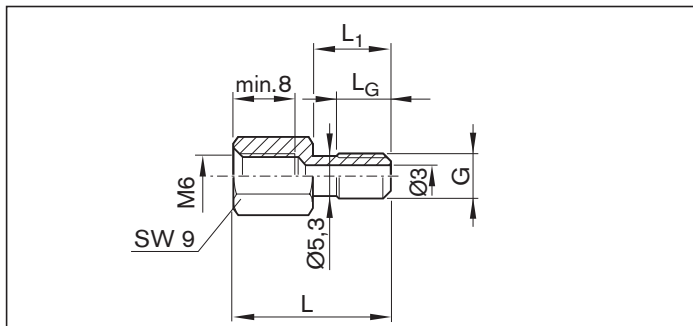

Material number	Dimensions (mm)				Mass (g)
	G	L	L ₁	L _G	
R3455 030 69	M6	21.0	10.5	7	5.0
R3455 030 87	M6	25.0	14.5	8	5.5
R3455 030 85	M6	26.5	16.0	7	5.0

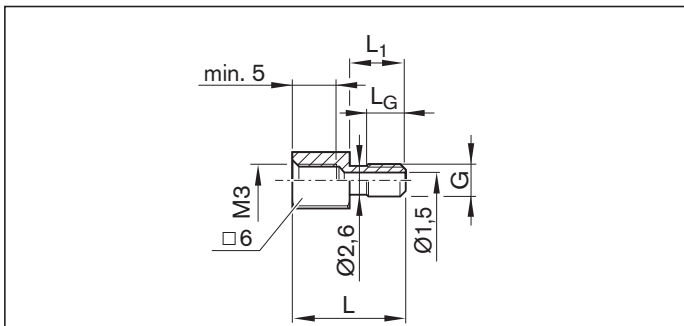

Material number	Dimensions (mm)				Mass (g)
	G	L	L ₁	L _G	
R3455 030 78	M3	16.5	8.5	6	2.5

Connectors

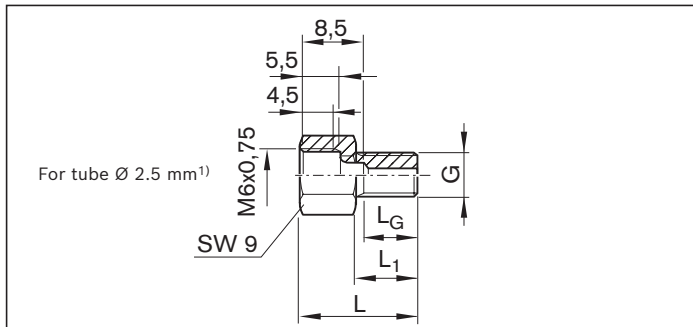

Material number	Dimensions (mm)				Mass (g)
	G	L	L ₁	L _G	
R3455 030 38	M6	15.5	8	6.5	4.1

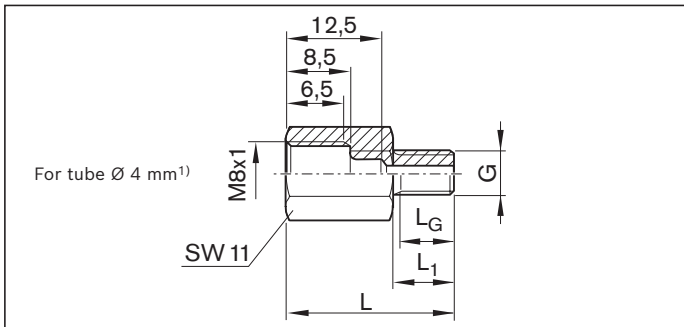

Material number	Dimensions (mm)				Mass (g)
	G	L	L ₁	L _G	
R3455 030 37	M6	22	8	6.5	8.8

1) For connections according to DIN 2353 (solderless tube fittings)

Swivel fittings

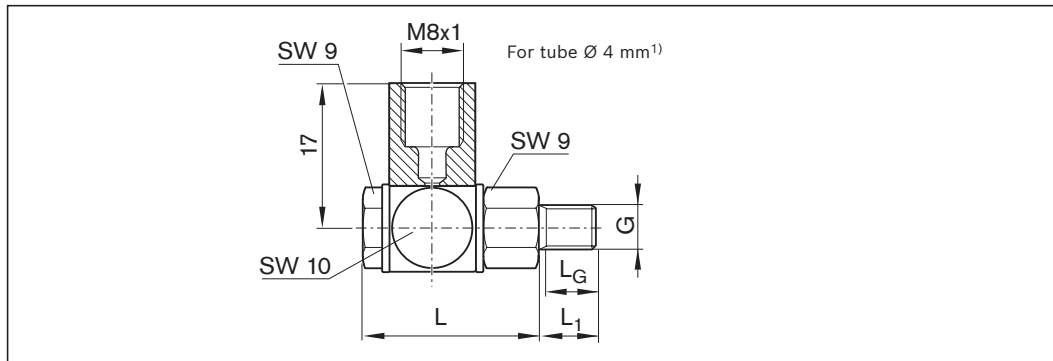

Material number	Dimensions (mm)				Mass (g)
	G	L	L ₁	L _G	
R3417 018 09	M6	21.5	8	6.5	18.6

1) For connections according to DIN 2353 (solderless tube fittings)

Straight connectors
Push-in fittings for plastic tubes and metal pipes

⚠ Not permitted for ball runner blocks with accessories on the end face

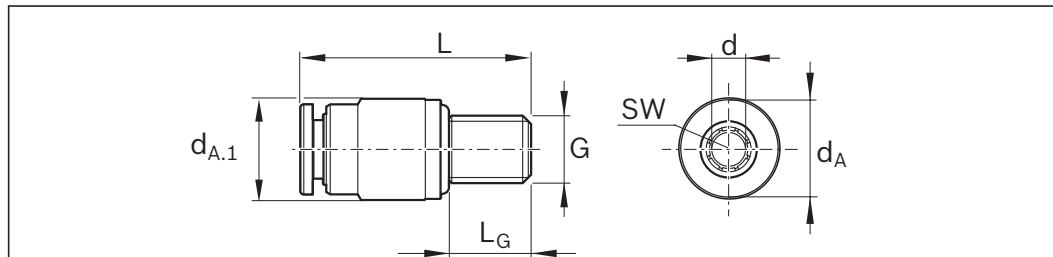

Material number	Dimensions (mm)							Mass (g)
	d _A	d _{A.1}	d±0.1	G	L	L _G	SW	
R3417 073 09	6.5	6.5	3	M3	16	5	1.5 ¹⁾	1.6
R3417 074 09	6.5	8	3	M5	16	5	2	2.5
R3417 075 09	9	9	4	M6	24.5	8	2.5	4.9
R3417 076 09	11	11	6	M6	26	8	2.5	6.2

1) Max. tightening torque: M_A = 0.5 Nm

Elbow plug-in connections rotatable¹⁾

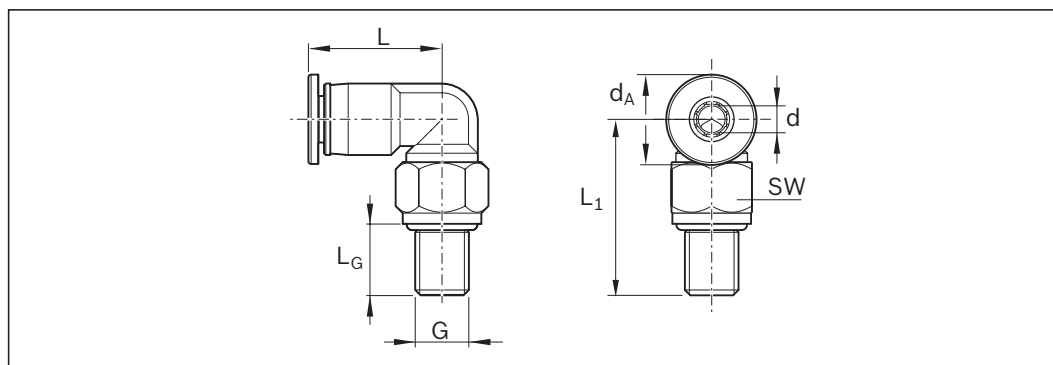

Material number	Dimensions (mm)							Mass (g)
	d _A	d±0.1	G	L	L ₁	L _G	SW	
R3417 077 09	6.5	3	M3	11.2	14.7	5	6 ²⁾	3.8
R3417 078 09	9	4	M6	18.1	18.1	8	9	10.8
R3417 079 09	11	6	M6	20.8	18.1	8	9	12.9

1) Max. lubrication pressure: 30 bar (exerting slow pressure with manual grease gun)
2) Max. tightening torque: M_A = 0.5 Nm

Product description

Rexroth offers limitless interchangeability as all ball guide rail versions can be combined at will with all accessories within each size.

The entire range is ideally geared to enable a top performance and meet all special requirements.

Overview of accessories for ball guide rails

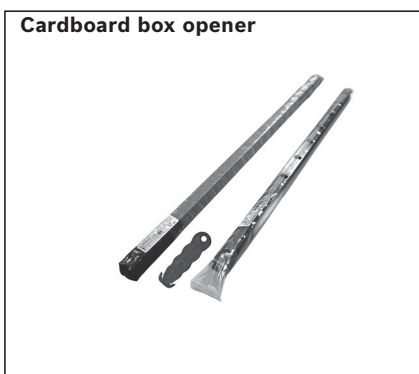
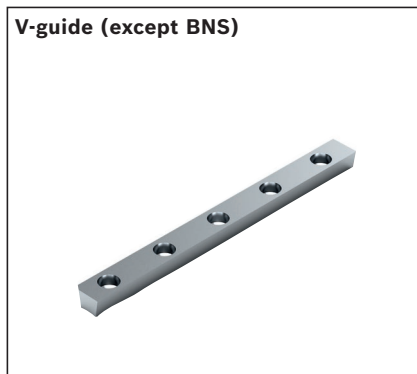
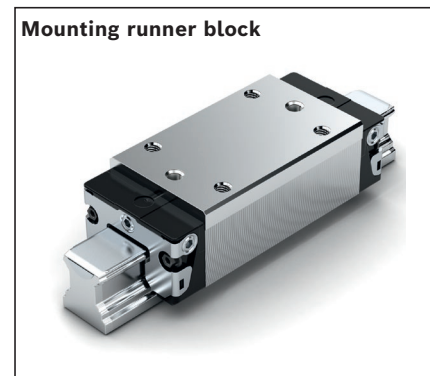
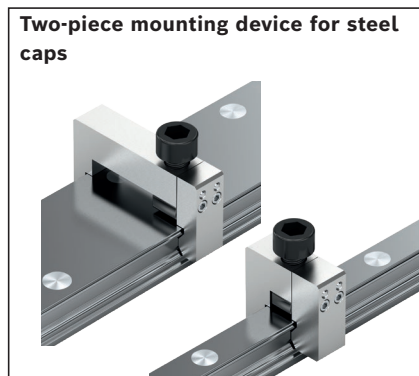
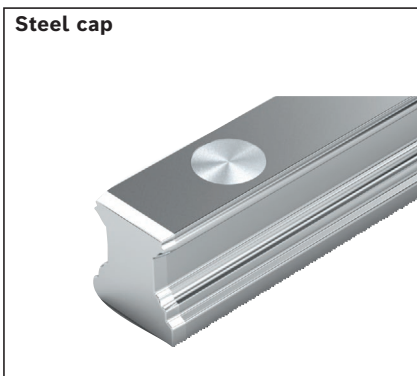
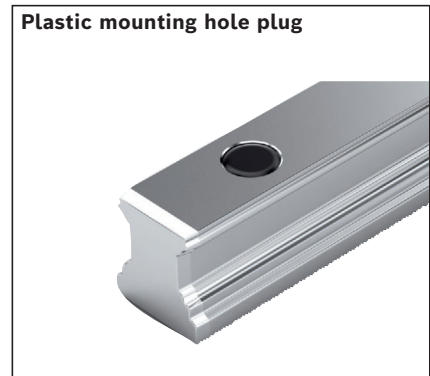
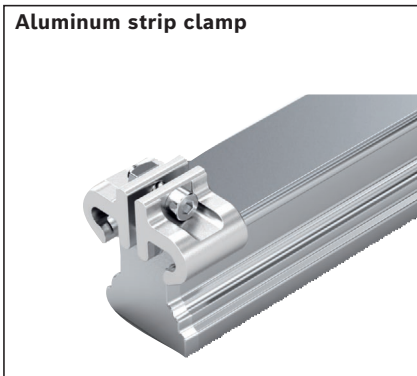
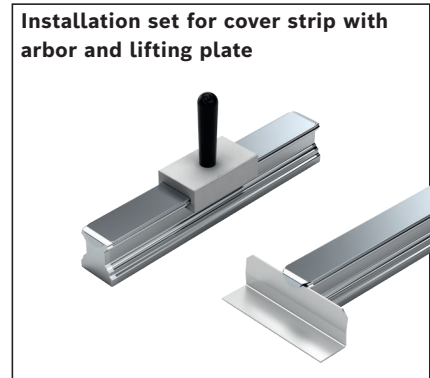
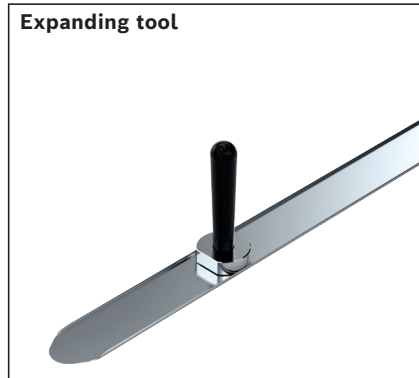
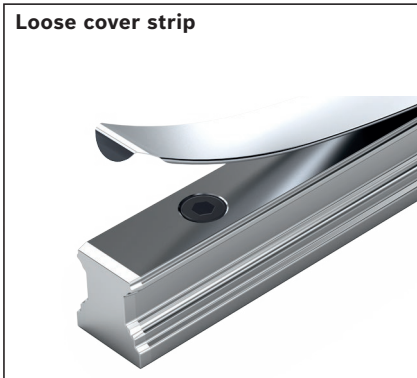

Cover strip

Instruction for mounting the cover strip

Secure the cover strip!

- ▶ Observe the instruction for mounting!
Please request the "Mounting instructions for cover strip".

Advantages

The cover strip is easy to clip on and remove.

- ▶ This considerably facilitates and speeds up the mounting process:
 - ▶ No need to plug every single bore.
 - ▶ No waiting time while waiting for adhesive to harden when using adhesive tape.
- ▶ Can be mounted and dismantled several times (up to four times).

Designs and functions

A Cover strip with snap fit (standard)

- ▶ The cover strip is clipped on before the ball runner block is mounted and fits tightly.

B Cover strip with sliding fit

- ▶ For mounting or replacing a cover strip, if the ball runner block or connection structure cannot be removed.
- ▶ A section of the snap fit cover strip is very slightly widened and can then be easily slid under the ball runner block.

An expanding tool for cover strips can be used to create a sliding fit after installation.

In particular, the sliding length L_S can be adapted in accordance with the installation case.

- ⚠ The cover strip is a precision-machined part that requires careful handling. Above all, it must not be bent.
Risk of injury at the edges and ends of the cover strip!
Wear gloves.

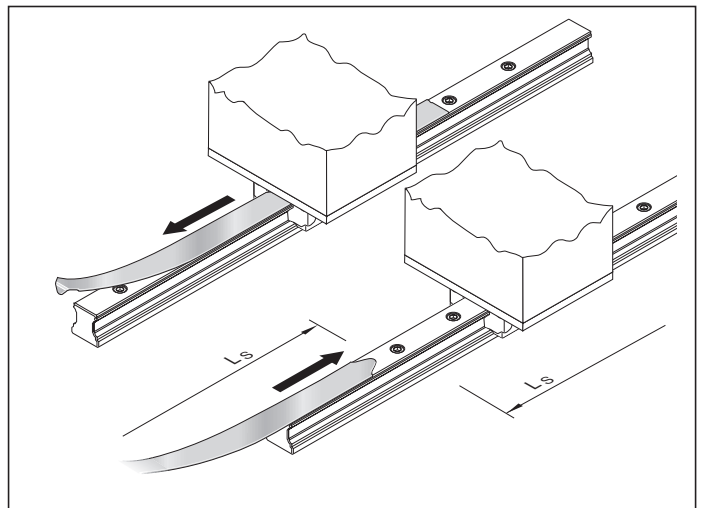
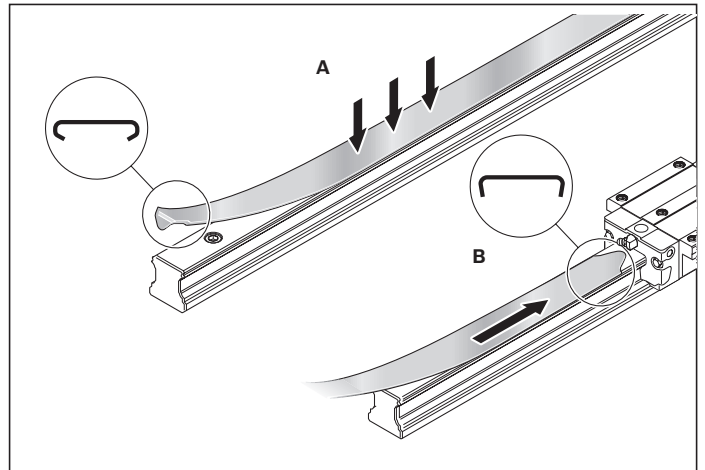
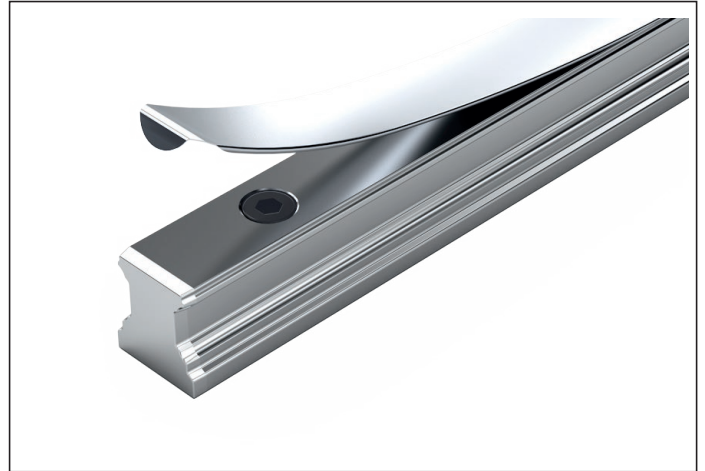

Material numbers, dimension drawing, dimensions and gravity see following pages.

Cover strip

Loose cover strip

For initial installation, storage and replacement

Note

A suitable cover strip with snap fit or with sliding fit is available for each ball guide rail SNS.

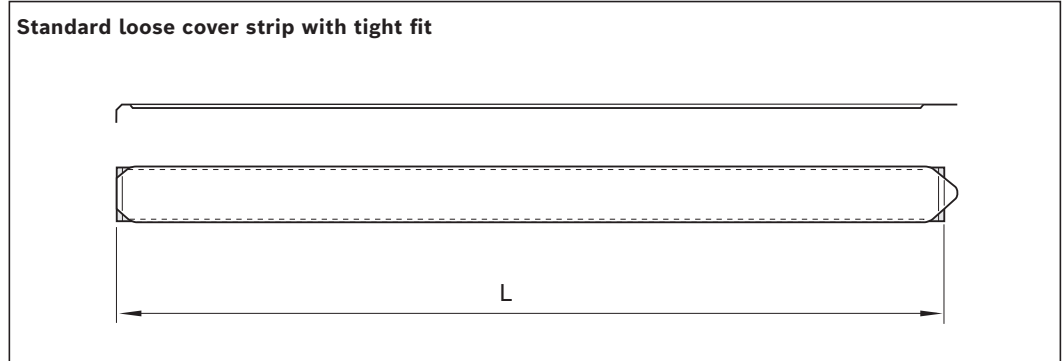

Ordering example 1 (standard cover strip with tight fit)

- ▶ Ball guide rail SNS
- ▶ Size 35
- ▶ Rail length
L = 2696 mm

Material number: **R1619 330 20, 2696 mm**

Size	Standard loose cover strip with tight fit Material number, rail length L (mm)	Mass (g/m)
15	R1619 130 00, ...	10
20	R1619 830 00, ...	29
25	R1619 230 00, ...	32
30	R1619 730 00, ...	40
35	R1619 330 20, ...	80
45	R1619 430 20, ...	100
55	R1619 530 20, ...	120
65	R1619 630 20, ...	148

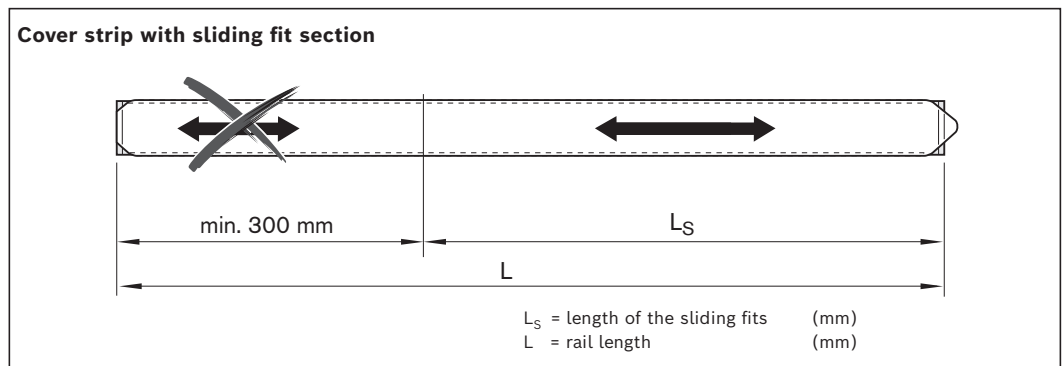

Ordering example 2 (cover strip with sliding fit section)

- ▶ Ball guide rail SNS
- ▶ Size 35
- ▶ Rail length
L = 2696 mm
- ▶ Length of sliding fit section
L_S = 1200 mm

Material number:

R1619 330 30, 2696, 1200 mm

Size	Cover strip with sliding fit section Material number, rail length L (mm), Length of sliding fit section L _S (mm)	Mass (g/m)
15	R1619 130 10, ...	10
20	R1619 830 10, ...	29
25	R1619 230 10, ...	32
30	R1619 730 10, ...	40
35	R1619 330 30, ...	80
45	R1619 430 30, ...	100
55	R1619 530 30, ...	120
65	R1619 630 30, ...	148

Expanding tool

For creating a sliding fit in the cover strip



Size	Material number	Mass (g)
15	R1619 115 10	40
20	R1619 815 10	50
25	R1619 215 10	80
30	R1619 715 10	100
35	R1619 315 30	100
45	R1619 415 30	130
55	R1619 515 30	210
65	R1619 615 30	270

Cover strip mounting kit

Mounting device and lift-off plate

Instruction for mounting

- ▶ To clip on the cover strip, a mounting device (A) is available; for removal, there is a lift-off plate (B).

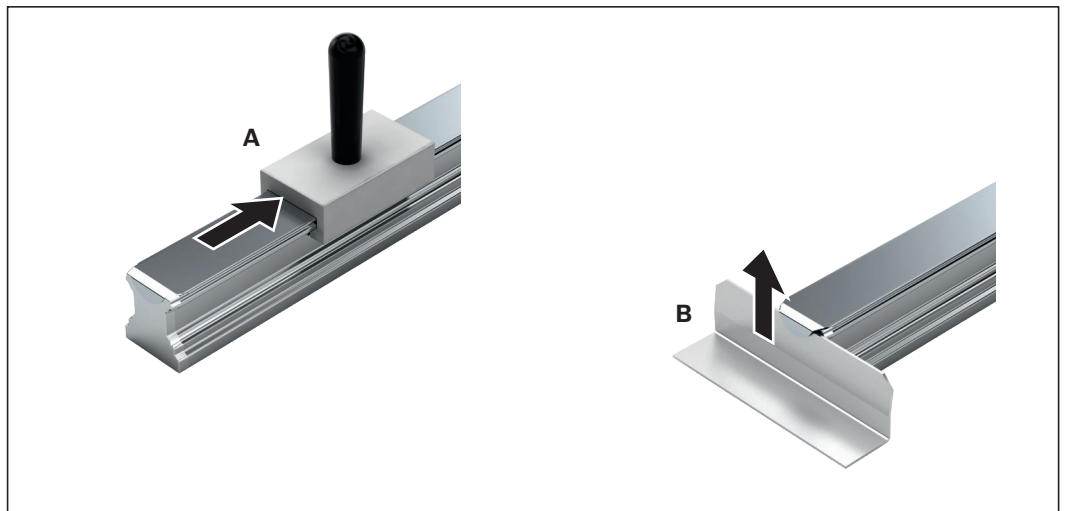

Size	Material number	Mass (g)
25	R1619 210 80	170
30	R1619 710 80	200
35	R1619 310 60	200
45	R1619 410 60	210
55	R1619 510 60	210
65	R1619 610 60	280

Observe the instruction for mounting!

- ▶ Please request the "Mounting instructions for cover strip".

Cover strip

Retainer for cover strip

Instruction for mounting

- ▶ Rexroth recommends the use of strip clamps:
- ▶ This prevents accidental lifting of the rail seal and infiltration of dirt
- ▶ Secures the cover strip

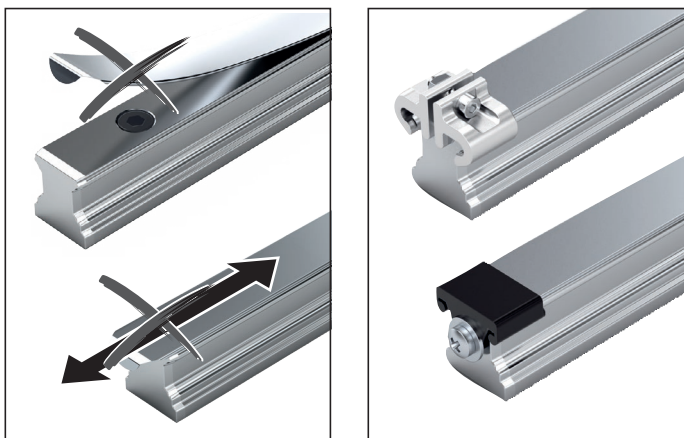

Strip clamps

For ball guide rails without threaded holes at the end faces

Material:

- ▶ Aluminum strip clamps (anodized)
- ▶ Clamping screw and nut made of corrosion-resistant steel as per DIN EN 10088

Size	Set (2 pieces per unit)		Bulk packaging (100 pieces per unit)			
	Material number (unit)	Mass (g)	Material number (unit)	Mass (kg)	Material number (unit)	Mass (kg)
15	R1619 139 50	11	R1619 139 60	0.55		
20	R1619 839 50	13	R1619 839 60	0.65		
25	R1619 239 50	14	R1619 239 60	0.70		
30	R1619 739 50	22	R1619 739 60	1.10		
35	R1619 339 50	30	R1619 339 60	1.50		
45	R1619 439 50	56	R1619 439 60	2.80		
55	R1619 539 50	62	R1619 539 60	3.10		
65	R1619 639 50	84	R1619 639 60	4.20		

Protective caps

For ball guide rails with threaded holes at the end faces

Material:

- ▶ Plastic protective cap, black
- ▶ Screw made of corrosion-resistant steel as per DIN EN 10088
- ▶ Washer made of galvanized steel

Size	Single cap		Set (2 pieces per unit with screw)		Bulk packaging	
	Material number (without screw)	Weight (g)	Material number (unit)	Mass (g)	Material number/piece (without screws)	Mass (kg)
15	R1619 139 00	0.8	R1619 139 20	5.5	R1619 139 01 / 1000	0.8
20	R1619 839 00	0.9	R1619 839 20	6.0	R1619 839 01 / 1000	0.9
25	R1619 239 00	1.0	R1619 239 20	7.0	R1619 239 01 / 1000	1.3
30	R1619 739 00	1.7	R1619 739 20	9.0	R1619 739 01 / 1000	1.7
35	R1619 339 00	2.0	R1619 339 20	10.0	R1619 339 01 / 1000	2.5
45	R1619 439 00	4.0	R1619 439 20	13.0	R1619 439 01 / 700	2.6
55	R1619 539 00	4.0	R1619 539 20	20.0	R1619 539 01 / 500	2.1
65	R1619 639 00	6.0	R1619 639 20	20.0	R1619 639 01 / 300	1.7

Caps

Plastic caps

Size	Single cap Material numbers	Mass (g)
15	R1605 100 80	0.05
20	R1605 800 80	0.10
25	R1605 200 80	0.30
30	R1605 300 80	0.60
35	R1605 300 80	0.60
45	R1605 400 80	1.00
55	R1605 500 80	1.70
65	R1605 600 80	2.10
20/40	R1605 100 80	0.05
25/70	R1605 200 80	0.30
35/90	R1605 300 80	0.60



Note

- ▶ Observe the instruction for mounting!
Please request the "Mounting instructions for ball rail systems."

Caps made of steel

Size	Single cap made of machining steel Material numbers	Mass (g)
25	R1606 200 75	2
30	R1606 300 75	3
35	R1606 300 75	3
45	R1606 400 75	6
55	R1606 500 75	8
65	R1606 600 75	9
25/70	R1606 200 75	2
35/90	R1606 300 75	3

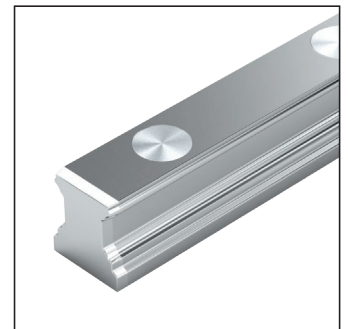

Notes

- ▶ Caps made of steel are not included in the scope of delivery of the ball guide rails.
Order the mounting tool too!
- ▶ Observe the instruction for mounting!
Please request the "Mounting instructions for ball rail systems."

Mounting tool for caps made of steel

Two-piece, with mounting instructions

The two-piece mounting tool is suitable for caps in built-in ball guide rail.

Size	Material numbers	Mass (kg)
25	R1619 210 00 ¹⁾	0.37
30	R1619 710 00 ¹⁾	0.37
35	R1619 310 10	0.57
45	R1619 410 10	0.85
55	R1619 510 10	1.50
65	R1619 610 00 ¹⁾	1.85
25/70	R1619 210 40	0.75
35/90	R1619 310 40	1.05

1) Can only be delivered as one part.

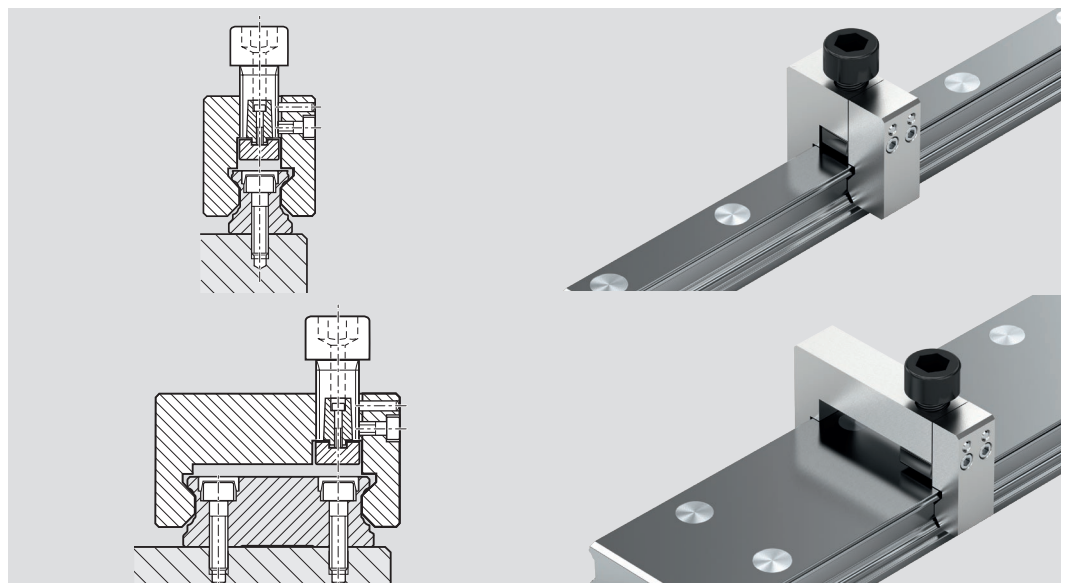

Mounting runner block

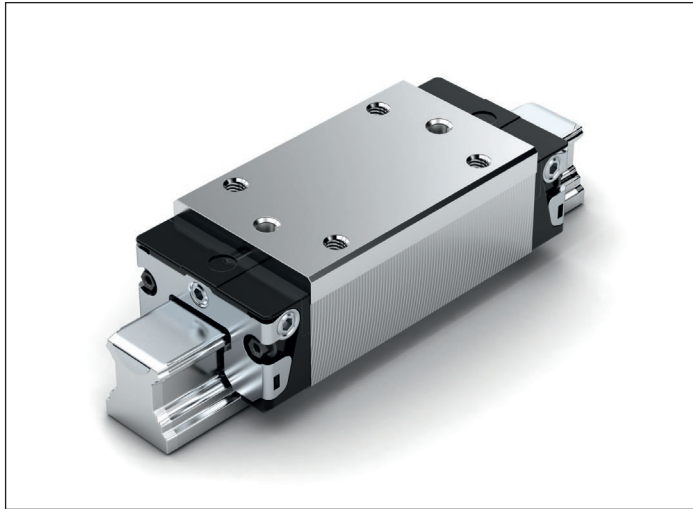

Mounting runner block

- ▶ For highly accurate parallel alignment of ball rail systems (types SNS and SNO)
- ▶ For joint alignment of multi-piece ball guide rails (types SNS and SNO)

Size	Material numbers	Dimensions (mm)				Mass (kg)
		A	B	T	D	
15	R1629 121 90	34	72.6	43	6	0.2
20	R1629 821 90	44	91	55	6	0.5
25	R1629 221 90	48	107.9	60	8	0.8
30	R1629 721 90	60	119.7	75	10	1.1
35	R1629 321 90	70	139	80	10	2.2
45	R1629 421 90	86	174.1	105	15	4.1
55	R1629 521 90	100	199	120	18	6.0
65	R1629 621 90	126	243	150	20	9.8

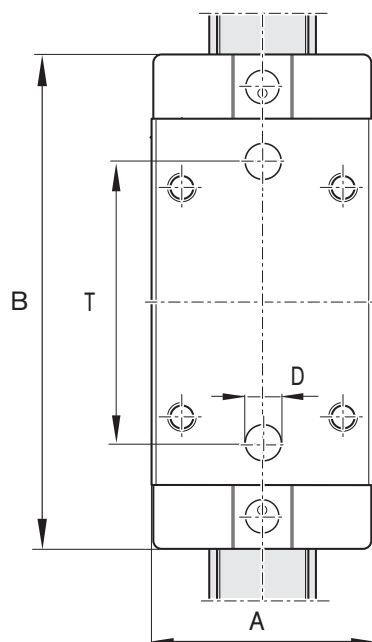

Mounting with mounting runner block

Alignment of parallel rails

- 1 Align and mount the first ball guide rail using a graduated straightedge.
- 2 Set up a mounting bridge with dial gauge between the ball runner blocks.
- 3 Move both ball runner blocks in parallel until the bores D of the mounting runner block are exactly over two fastening bores of the rail (provided that the drilling distances of the rail correspond to the spacing T).
- 4 Align the ball guide rail manually until the dial gauge shows the correct dimension.
- 5 Tighten the screws through the mounting runner block.

Alignment of the multi-piece rails

- 1 Slide the multi-piece rails together at the joint.
- 2 Slide the mounting runner block over the center of the joint until both screw heads are visible. This is the case when the hole center distance of the joint corresponds to hole spacing T. If this is not the case, continue with point 5.
- 3 The mounting runner block automatically aligns the rails at the joint.
- 4 Tighten the screws through the mounting runner block.
- 5 If the screw center distances of the guide rail at the joint are not equal to the spacing and deviate from the hole spacing T of the mounting runner block, each screw must be tightened individually and then moved to the next hole.

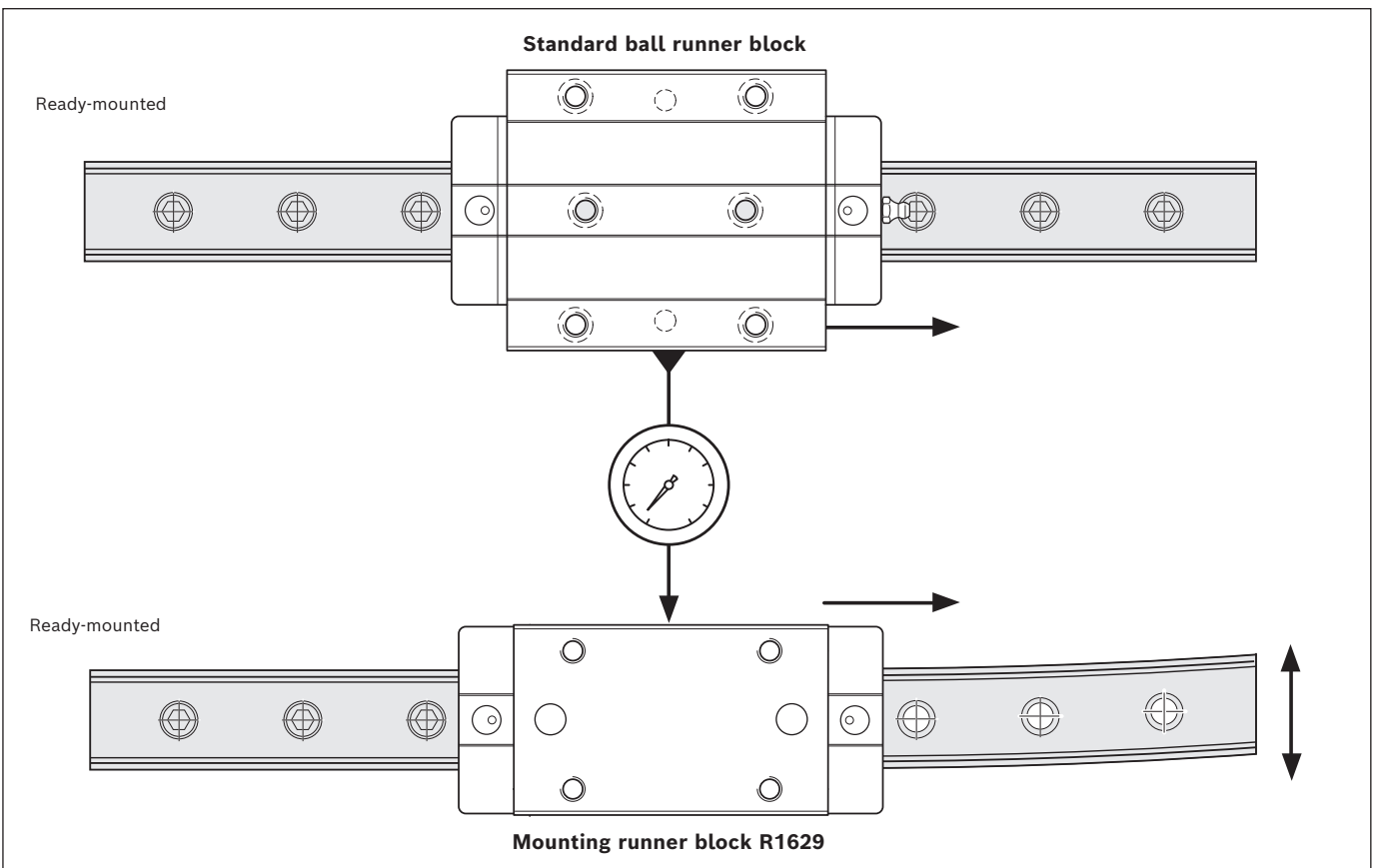

V-guide

V-guide

Lateral retention of ball guide rails

- ▶ Material: Steel
- ▶ Design: Black finished

Note

- ▶ Observe the instruction for mounting!
Please request the "Mounting instructions for ball rail systems."

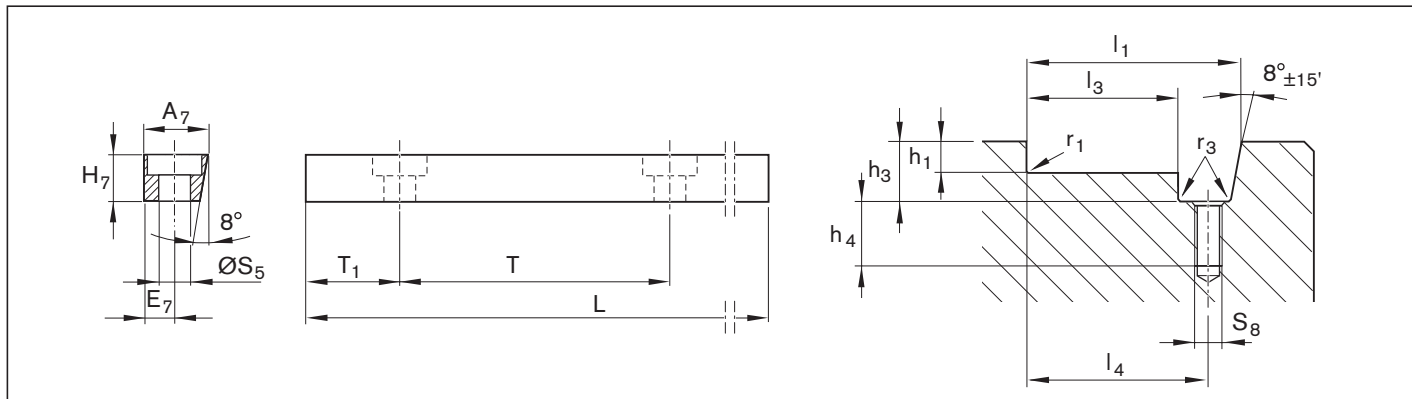
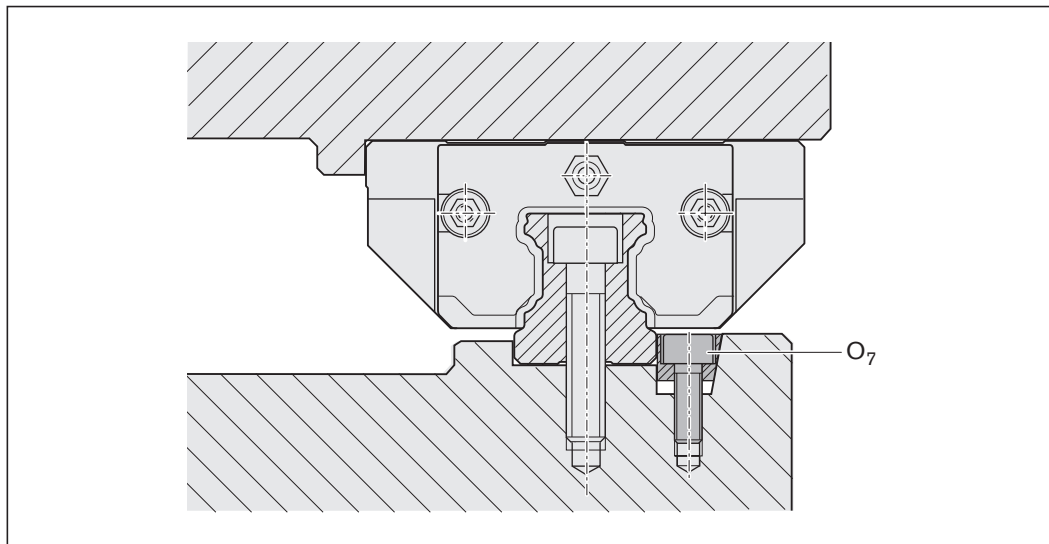

V-guide

Size	Material number	Dimensions (mm)								Mass (kg)
		A ₇	E ₇	H ₇	L	O ₇ ¹⁾	S ₅	T	T ₁	
15	R1619 200 01	12.0	6	10	957	M5x20	6.0	60	28.5	0.8
20										
25										
30										
35										
45	R1619 400 01	19.0	9	16	942	M8x25	9.0	105	51.0	2.0
55										
65										

1) Screw O₇ according to DIN 6912

V-guide slot

Size	Dimensions (mm)									
	h _{1-0.2}	h ₃ ⁺¹	h ₄ ⁺²	l ₁ ^{±0.05}	l ₃ ^{-0.1}	l ₄ ^{±0.1}	r ₁ max	r ₃ max	S ₈	
15	3.5	12.5	15	27	14.9	21	0.4	0.5	M5	
20	4.0	12.5	15	32	19.9	26	0.5	0.5	M5	
25	4.0	12.5	15	35	22.9	29	0.8	0.5	M5	
30	5.0	12.5	15	40	27.9	34	0.8	0.5	M5	
35	6.0	12.5	15	46	33.9	40	0.8	0.5	M5	
45	8.0	19.0	16	64	44.9	54	0.8	0.5	M8	
55	10.0	19.0	16	72	52.9	62	1.2	0.5	M8	
65	10.0	19.0	16	82	62.9	72	1.2	0.5	M8	

Cardboard box opener



- ▶ Tool for opening the guide rails packaging.
- ▶ Prevents risk of injury

Ordering data

Material number R320105175

Product description hydraulic clamping and braking units

Application areas

Clamping

- ▶ During mounting work and standstill of the machine **with** energy with hydraulic clamping and braking units (KBH)
- ▶ Of heavy handling systems
- ▶ Clamping of machine tables from heavily machined machining centers

Brakes

- ▶ Support as brake for linear motors
- ▶ Of heavy handling systems

Characteristic features

- ▶ Very high axial holding forces
- ▶ Dynamic and static stabilization in the axial direction
- ▶ Heavy-duty brake

⚠ Observe the safety instructions on clamping and braking units.

Further highlights

- ▶ Up to 1 million clamping cycles.
- ▶ Up to 2000 emergency braking operations
- ▶ Threaded on both sides for the hydraulic connection
- ▶ Solid, rigid steel housing, chemically nickel-plated
- ▶ High positioning accuracy
- ▶ Release pressure 150 bar
- ▶ Integrated all-round sealing
- ▶ Special pressure diaphragm technology for maximum functional reliability without pressure losses or leakage
- ▶ Brake shoes with integrated positive-locking, large-surface contact profiles for maximum axial rigidity
- ▶ Super heavy-duty model

Special features of hydraulic clamping and braking units (KBH):

- ▶ Low displacement
- ▶ Compact design, compatible with DIN 645
- ▶ 10 million clamping cycles (B10d value)

Functional principle

Hydraulic pressure: 50 - 150 bar

Clamps and brakes with compression

The large-scale clamping profiles are pressed directly through the hydraulic oil via a piston principle to the flanks of the ball guide rail.

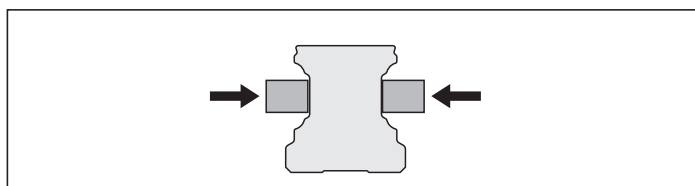

Hydraulic pressure: 0 bar

Decompression with spring force

A preloaded return spring allows for short decompression cycles.

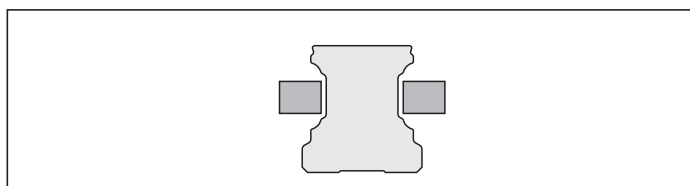

KBH, FLS

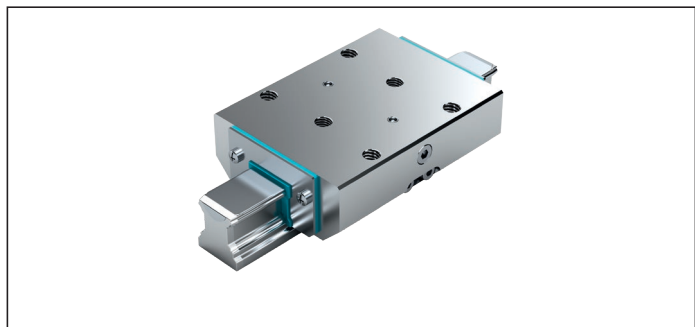

KBH, SLS

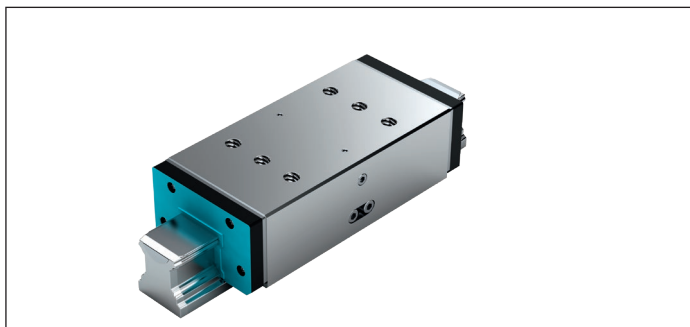

Additional information

Hydraulic connections

The hydraulic clamping units are pre-filled with HLP 46 at the factory. The hydraulic connection is attached on two sides. One connection is suitable for pressurization. Take care when venting fixed and flexible hydraulic lines because air ports can damage sealing elements.

Connection structure, mounting the clamping units

To prevent detrimental effects, e.g. permanent grinding on the linear guide, the connection structure must be rigid and in accordance with its load and requirements. If the clamping units tilt, this can result in contact, wear and therefore damage to the linear guide.

The setting at the factory is adapted for the linear guide and may not be altered when mounting. It is imperative to observe the mounting instructions for the clamping and braking units and the linear guides.

Some spring-loaded accumulators are equipped with a transport lock between the contact profiles.

This must be removed when mounting by pressurizing the unit. When pressure is removed, the transport lock or the associated linear guide must always lie between the contact profiles.

The clamping units do not have any guiding function. A runner block can therefore not be replaced with a clamping unit.

The ideal position of the clamping unit lies between two runner blocks.

When using several clamping units, these should be distributed evenly on both guide rails in order to attain a maximum rigidity of the overall construction.

Lubrication

When using the prescribed pressurizing medium, lubrication is not required.

Surface protection

All housings of the clamping units are chemically nickel-plated and therefore have limited rust protection.

Aluminum subsections are chemically nickel-plated or hard-coated according to their requirement.

B10d value

The B10d value specifies the number of switching cycles until 10% of components fail dangerously.

Hydraulic clamping and braking units, KBH, FLS

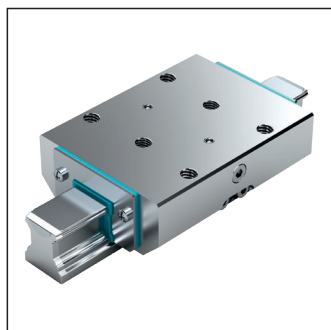

FLS

Flange, long, standard height

R1619 .40 21

Note

Can be used on all ball guide rails SNS.

Clamps and brakes with compression

- ▶ Max. hydraulic operating pressure:
 - ▶ Size 25: 100 bar
 - ▶ Sizes 35 - 65: 150 bar
- ▶ Operating temperature range t: 0 – 70 °C

Note on lubrication

- ▶ Initial filling of hydraulic oil HLP46
- ▶ Check for compatibility when using different oils

⚠ Observe the safety instructions on clamping and braking units.

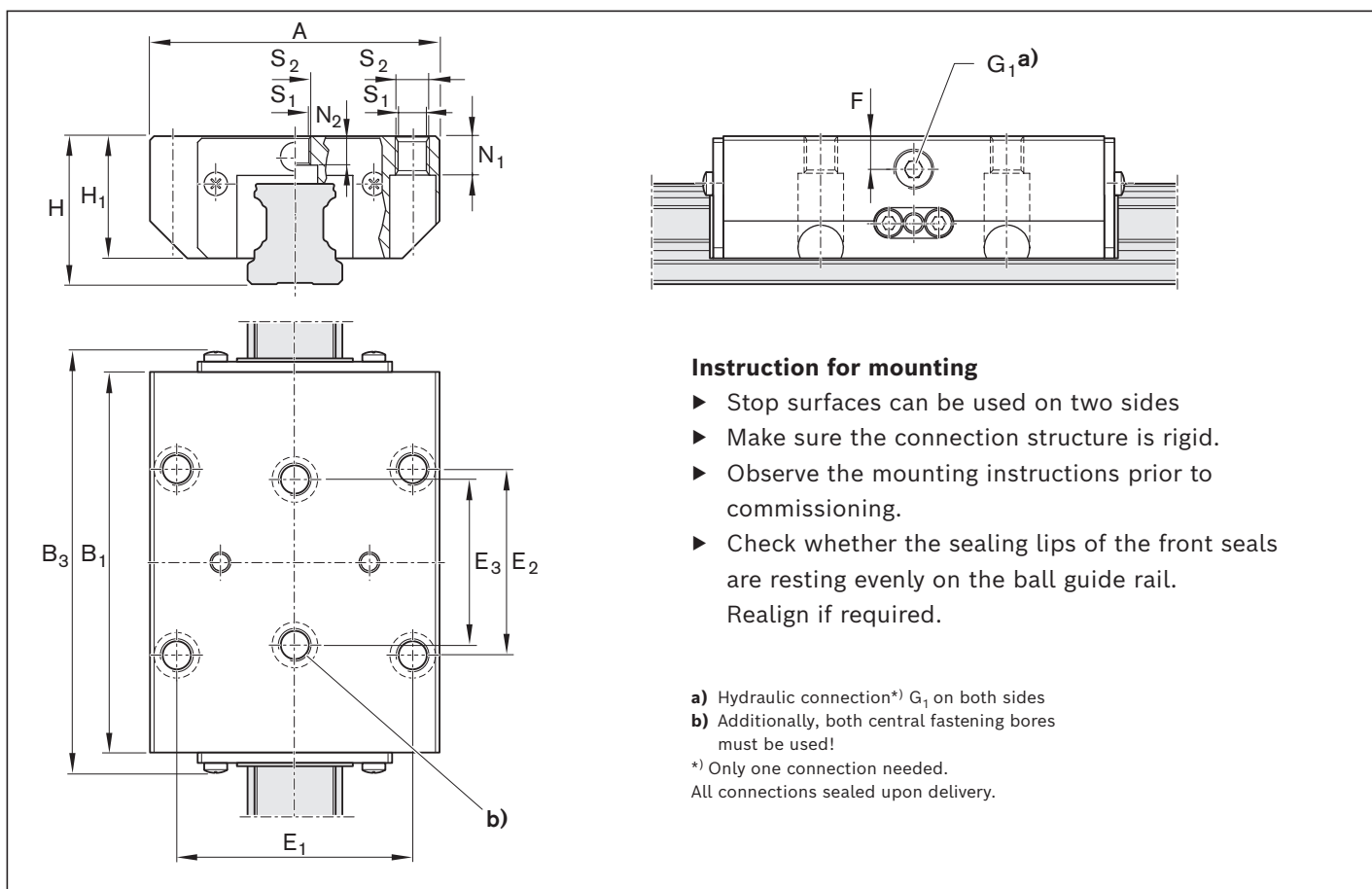

Size	Material number	Holding force ¹⁾ (N)	Dimensions (mm)													Displacement ⁶⁾ (cm ³)	Mass (kg)	
			A	B ₁	B _{3max}	H	H ₁	E ₁	E ₂	E ₃	F	G ₁	N ₁ ⁴⁾	N ₂ ⁵⁾	S ₁			S ₂
25	R1619 240 21	2,200 ²⁾	70	92.0	102.3	36	29.5	57	45	40	8	1/8"	9	7.0	6.8	M8	0.6	1.10
35	R1619 340 21	5700 ³⁾	100	120.5	141.0	48	40.0	82	62	52	12	1/8"	12	10.2	8.6	M10	1.1	2.69
45	R1619 440 21	9900 ³⁾	120	155.0	178.0	60	50.0	100	80	60	15	1/8"	15	12.4	10.5	M12	1.8	5.20
55	R1619 540 21	13700 ³⁾	140	184.0	209.0	70	57.0	116	95	70	16	1/8"	18	13.5	12.5	M14	2.4	8.40
65	R1619 640 21	22700 ³⁾	170	227.0	264.0	90	76.0	142	110	82	20	1/4"	23	14.0	14.5	M16	3.8	17.30

1) The inspection is done in a mounted state with a lubricated layer (ISO-VG 68).
 2) At 100 bar
 3) At 150 bar

4) For bolting from below with ISO 4762
 5) For bolting from below with DIN 7984
 6) Per clamping

Hydraulic clamping and braking units, KBH, SLS

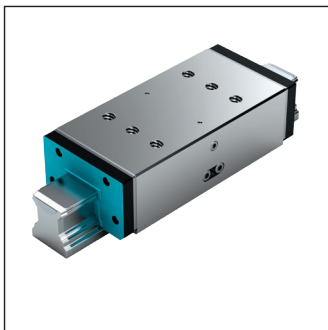

SLS

Slimline, long, standard height

R1619 .40 20

Note

Can be used on all ball guide rails SNS.

Clamps and brakes with compression

- ▶ Max. hydraulic operating pressure:
- ▶ Size 65: 150 bar
- ▶ Operating temperature range t: 0 – 70 °C

Note on lubrication

- ▶ Initial filling of hydraulic oil HLP46
- ▶ Check for compatibility when using different oils

! Observe the safety instructions on clamping and braking units.

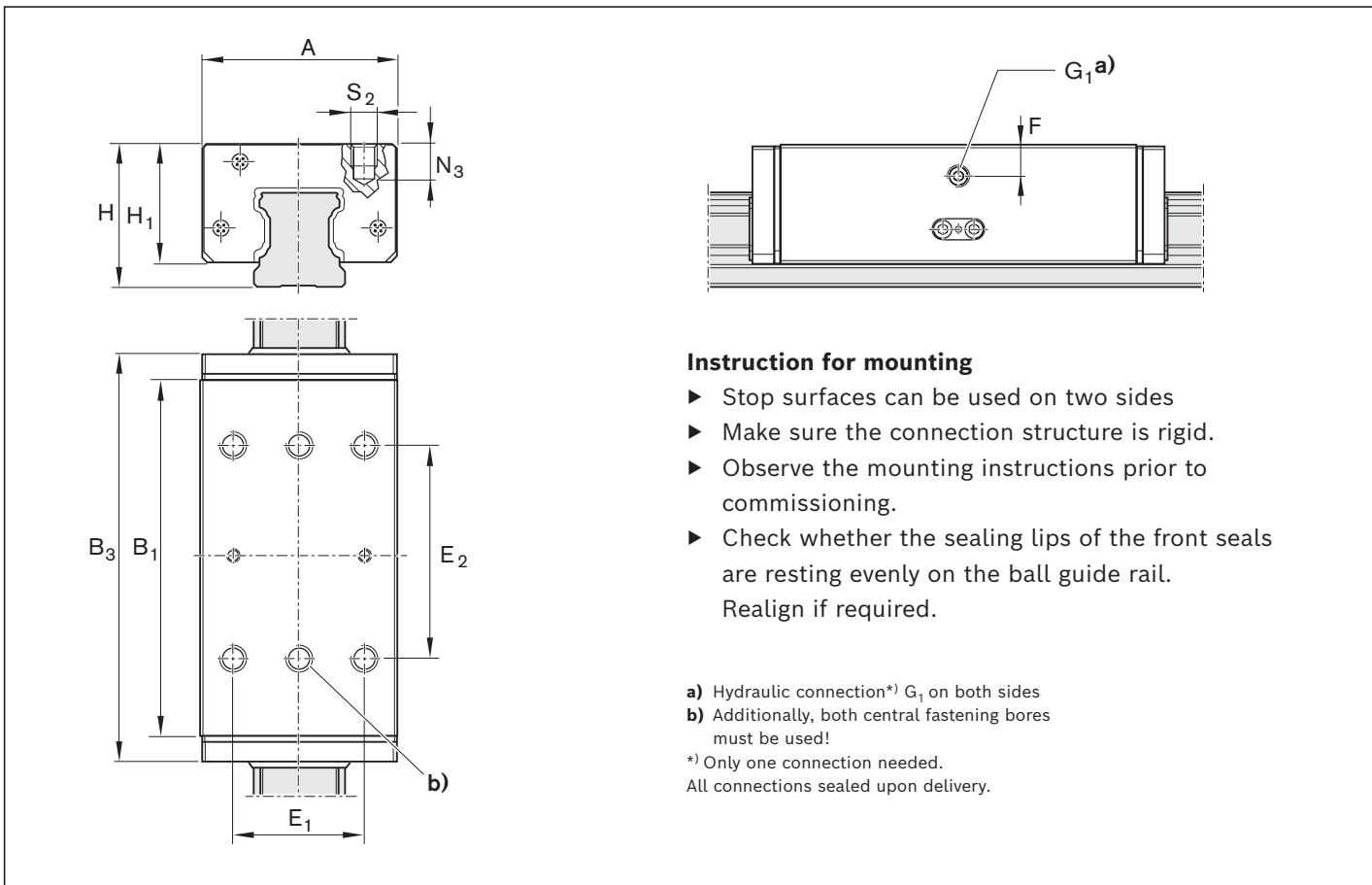

Size	Material number	Holding force ¹⁾ (N)	Dimensions (mm)											Displacement ³⁾ (cm ³)	Mass (kg)
			A	B ₁	B _{3max}	H	H ₁	E ₁	E ₂	F	G ₁	N ₃	S ₂		
65	R1619 640 20	22700 ²⁾	126	227	264	90	76	76	120	20	1/4"	21	M16	3.8	14.40

1) The inspection is done in a mounted state with a lubricated layer (ISO-VG 68).
 2) At 100 bar
 3) Per clamping

Hydraulic clamping units product description

Application areas

- ▶ Clamping of heavy handling systems
- ▶ Clamping of machine tables from heavily machined machining centers

Characteristic features

- ▶ Very high axial holding forces
- ▶ Compact design, compatible with DIN 645
- ▶ Dynamic and static stabilization in the axial direction

⚠ Observe the safety instructions on clamping and braking units.

Further highlights

- ▶ Threaded on both sides for the hydraulic connection
- ▶ Solid, rigid steel housing, chemically nickel-plated
- ▶ High positioning accuracy
- ▶ Continuously adjustable pressure from 50 - 150 bar
- ▶ Integrated all-round sealing
- ▶ Special pressure diaphragm technology for maximum functional reliability without pressure losses or leakage
- ▶ Integrated positive-locking, large-surface contact profiles for maximum axial rigidity

Special features of the hydraulic clamping and braking units (KWH):

- ▶ 10 million clamping cycles (B10d value)

Functional principle

Hydraulic pressure: 50 - 150 bar

Clamps with compression

The large-scale clamping profiles are pressed directly through the hydraulic oil via a piston principle to the flanks of the ball guide rail.

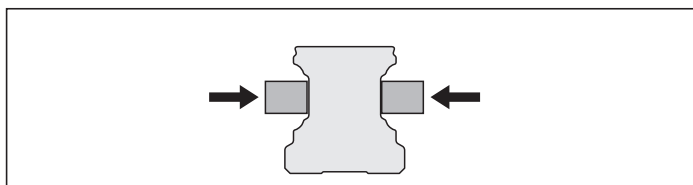

Hydraulic pressure: 0 bar

Decompression with spring force

A preloaded return spring allows for short decompression cycles.

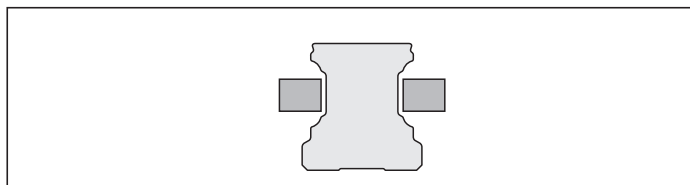

Model overview of accessories for hydraulic clamping units

KWH, FLS

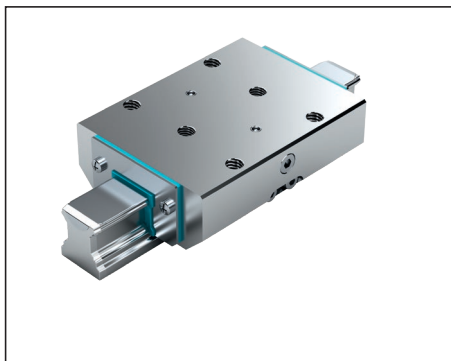

KWH, SLS

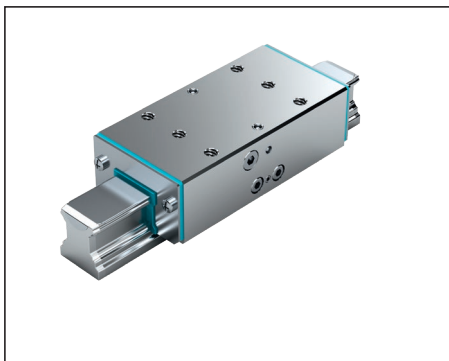

KWH, SLH

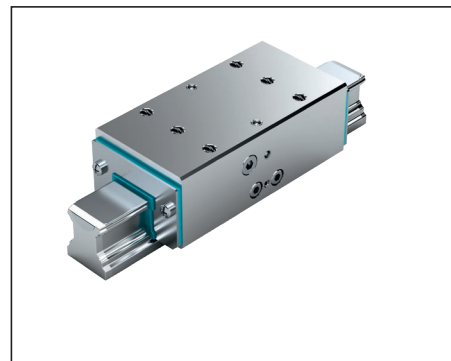

Technical data and calculations

Normal forces and retaining forces

Measured values with the hydraulic clamping unit KWH, FLS flange, long, standard height, size 25 - 65

Max. hydraulic operating pressure:

- ▶ Sizes 25 - 30: 100 bar
- ▶ Sizes 35 - 65: 150 bar

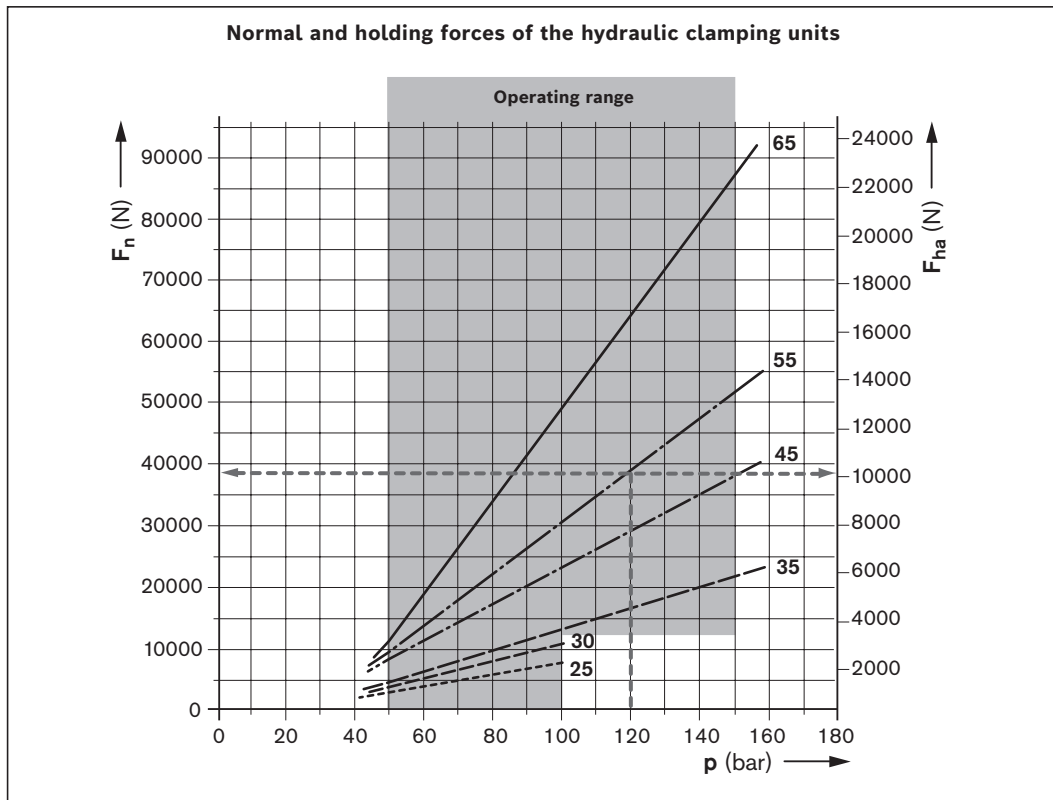

Calculation of the holding force

Holding force for hydraulic clamping units

$$F_{ha} = F_n \cdot 2 \cdot \mu_0$$

Normal (perpendicular) force (measured): F_n see diagram
 Stiction coefficient: $\mu_0 = 0.13$ (approx.) for steel/steel, lubricated, in relation to the ball guide rail

Calculation example: Clamping unit KWH, size 55

Pressure: $p = 120$ bar
 Normal (perpendicular) force: $F_n = 38500$ N (see diagram)
 Holding force: $F_{ha} = 38500 \text{ N} \cdot 2 \cdot 0.13 = 10010$ N

Permissible holding force for hydraulic clamping units

$$F_{ha, perm} = F_{ha} / f_s$$

The safety factor f_s depends on:

- ▶ Vibrations
- ▶ Force surges
- ▶ Application-specific requirements etc.

Example: Clamping unit KWH, size 55

Holding force: $F_{ha} = 10010$ N (see calculation example)
 Safety factor: $f_s = 1.25$ (assumed)
 Permissible holding force: $F_{ha, perm} = 10010 \text{ N} / 1.25 \approx 8000$ N

- f_s = Safety factor (-)
- F_{ha} = Holding force (N) (with $\mu_0 = 0.13$)
- $F_{ha, perm}$ = Permissible holding force (N)
- F_n = Normal (perpendicular) force (N)
- μ_0 = Stiction coefficient: (-)
- p = Pressure (bar)

Hydraulic clamping units KWH, FLS

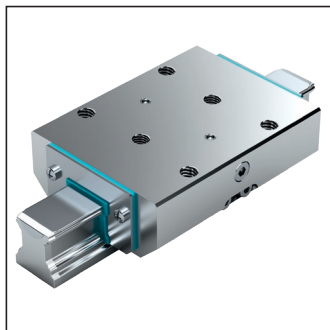

FLS Flange, long, standard height

R1619 .42 11

Note

Can be used on all ball guide rails SNS.

Clamps with compression

- ▶ Max. hydraulic operating pressure:
 - ▶ Sizes 25 - 30: 100 bar
 - ▶ Sizes 35 - 65: 150 bar
- ▶ Operating temperature range t: 0 – 70 °C

Note on lubrication

- ▶ Initial filling of hydraulic oil HLP46
- ▶ Check for compatibility when using different oils

⚠ Observe the safety instructions on clamping and braking units.

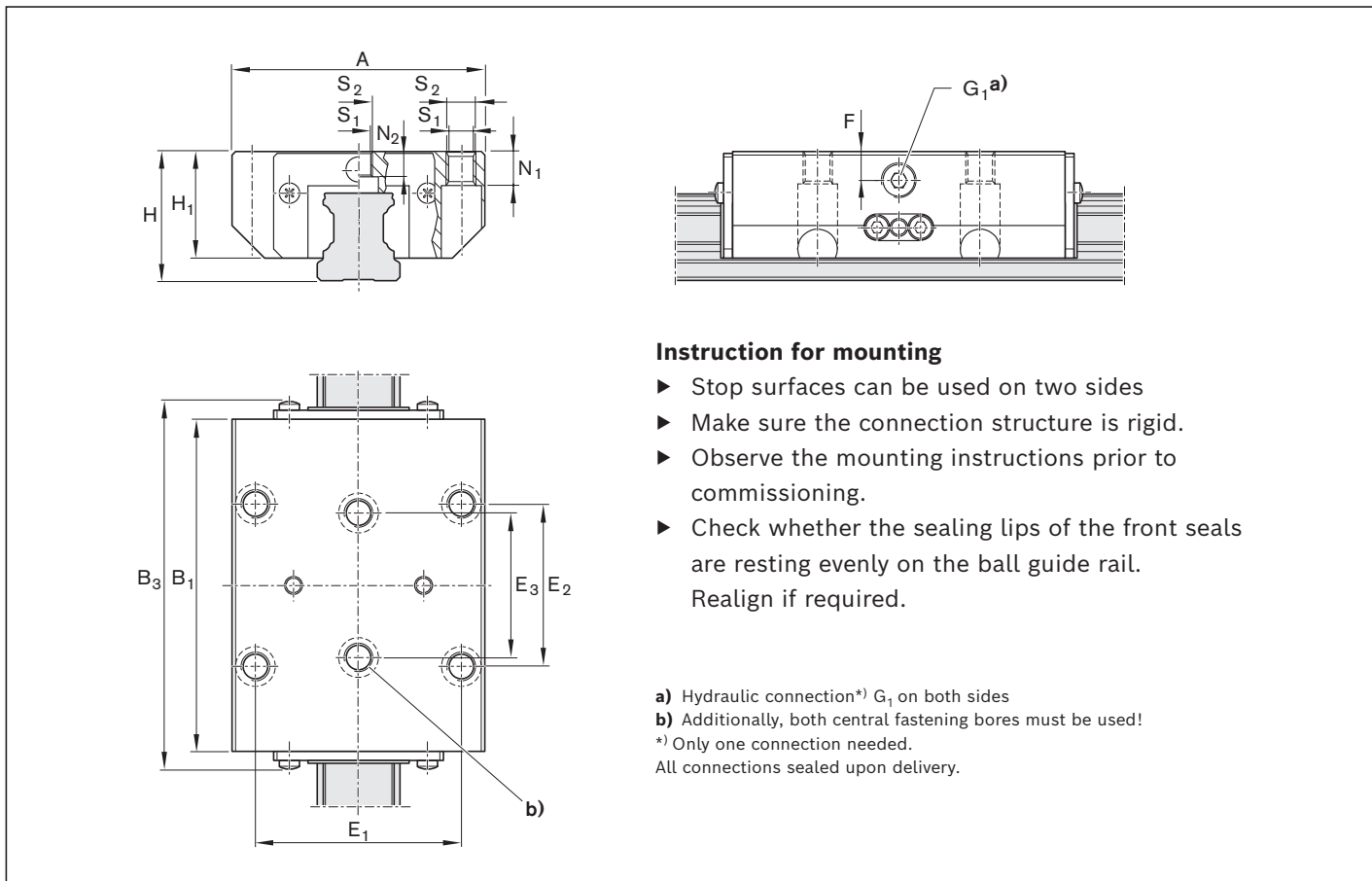

Instruction for mounting

- ▶ Stop surfaces can be used on two sides
- ▶ Make sure the connection structure is rigid.
- ▶ Observe the mounting instructions prior to commissioning.
- ▶ Check whether the sealing lips of the front seals are resting evenly on the ball guide rail. Realign if required.

a) Hydraulic connection*) G₁ on both sides
 b) Additionally, both central fastening bores must be used!
 *) Only one connection needed.
 All connections sealed upon delivery.

Size	Material number	Holding force ¹⁾ (N)	Dimensions (mm)														Displacement ⁶⁾ (cm ³)	Mass (kg)
			A	B ₁	B _{3max}	H	H ₁	E ₁	E ₂	E ₃	F	G ₁	N ₁ ⁴⁾	N ₂ ⁵⁾	S ₁	S ₂		
25	R1619 242 11	2,200 ²⁾	70	92.0	102.3	36	29.5	57	45	40	8.0	1/8"	9	7.0	6.8	M8	0.6	1.22
30	R1619 742 11	3000 ²⁾	90	103.5	115.4	42	35.0	72	52	44	10.5	1/8"	11	8.0	8.6	M10	0.7	2.09
35	R1619 342 11	5700 ³⁾	100	120.5	133.0	48	40.0	82	62	52	12.0	1/8"	12	10.2	8.6	M10	1.1	2.69
45	R1619 442 11	9900 ³⁾	120	155.0	170.0	60	50.0	100	80	60	15.0	1/8"	15	12.4	10.5	M12	1.8	5.32
55	R1619 542 11	13700 ³⁾	140	184.0	201.0	70	57.0	116	95	70	16.0	1/8"	18	13.5	12.5	M14	2.4	8.40
65	R1619 642 11	22700 ³⁾	170	227.0	256.0	90	76.0	142	110	82	20.0	1/4"	23	14.0	14.5	M16	3.8	17.30

1) The inspection is done in a mounted state with a lubricated layer (ISO-VG 68). Permissible holding force φ 173
 2) At 100 bar
 3) At 150 bar

4) For bolting from below with ISO 4762
 5) For bolting from below with DIN 7984
 6) Per clamping

Hydraulic clamping units KWH, SLS

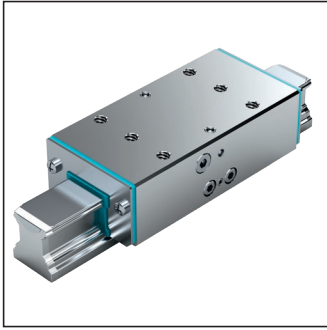

SLS - Slimline, long, standard height

R1619 .42 51

Note

Can be used on all ball guide rails SNS.

Clamps with compression

- ▶ Max. hydraulic operating pressure:
 - ▶ Sizes 25 - 45: 100 bar
 - ▶ Sizes 55 - 65: 150 bar
- ▶ Operating temperature range t: 0 – 70 °C

Note on lubrication

- ▶ Initial filling of hydraulic oil HLP46
- ▶ Check for compatibility when using different oils

⚠ Observe the safety instructions on clamping and braking units.

Instruction for mounting

- ▶ Stop surfaces can be used on two sides
- ▶ Make sure the connection structure is rigid.
- ▶ Observe the mounting instructions prior to commissioning.
- ▶ Check whether the sealing lips of the front seals are resting evenly on the ball guide rail. Realign if required.

a) Hydraulic connection*) G₁ on both sides
 b) Hydraulic connection*) G₁ on both sides for sizes 25 - 30
 c) In addition, both fastening bores must be used!
 *) Only one connection needed.
 All connections sealed upon delivery.

Size	Material number	Holding force ¹⁾ (N)	Dimensions (mm)											Displacement ⁴⁾ (cm ³)	Mass (kg)
			A	B ₁	B _{3 max}	H	H ₁	E ₁	E ₂	F	G ₁	N ₃	S ₂		
25	R1619 242 51	1600 ²⁾	48	92.0	102.3	36	29.5	35	50	8	1/8"	8	M6	0.6	1.22
30	R1619 742 51	3000 ²⁾	60	103.5	115.4	42	35.0	40	60	9	1/8"	8	M8	0.7	2.09
35	R1619 342 51	3500 ²⁾	70	120.5	134.0	48	40.0	50	72	12	1/8"	13	M8	1.1	2.02
45	R1619 442 51	7400 ²⁾	86	155.0	170.0	60	50.0	60	80	15	1/8"	15	M10	1.8	4.00
55	R1619 542-51	13700 ³⁾	100	184.0	201.0	70	57.0	75	95	16	1/8"	18	M12	2.4	6.10
65	R1619 642 51	22700 ³⁾	126	227.0	256.0	90	76.0	76	120	20	1/4"	21	M16	3.8	14.40

1) The inspection is done in a mounted state with a lubricated layer (ISO-VG 68). Permissible holding force 173
 2) At 100 bar
 3) At 150 bar
 4) Per clamping

Hydraulic clamping units KWH, SLH

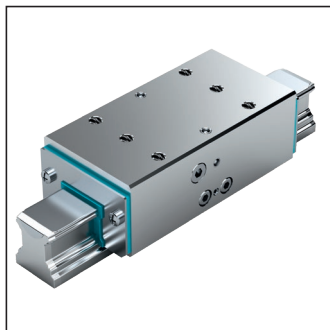

SLH - Slimline, long, high

R1619 .42 31

Note

Can be used on all ball guide rails SNS.

Clamps with compression

- ▶ Max. hydraulic operating pressure:
 - ▶ Sizes 25 - 45: 100 bar
 - ▶ Size 55 : 150 bar
- ▶ Operating temperature range t: 0 – 70 °C

Note on lubrication

- ▶ Initial filling of hydraulic oil HLP46
- ▶ Check for compatibility when using different oils

⚠ Observe the safety instructions on clamping and braking units.

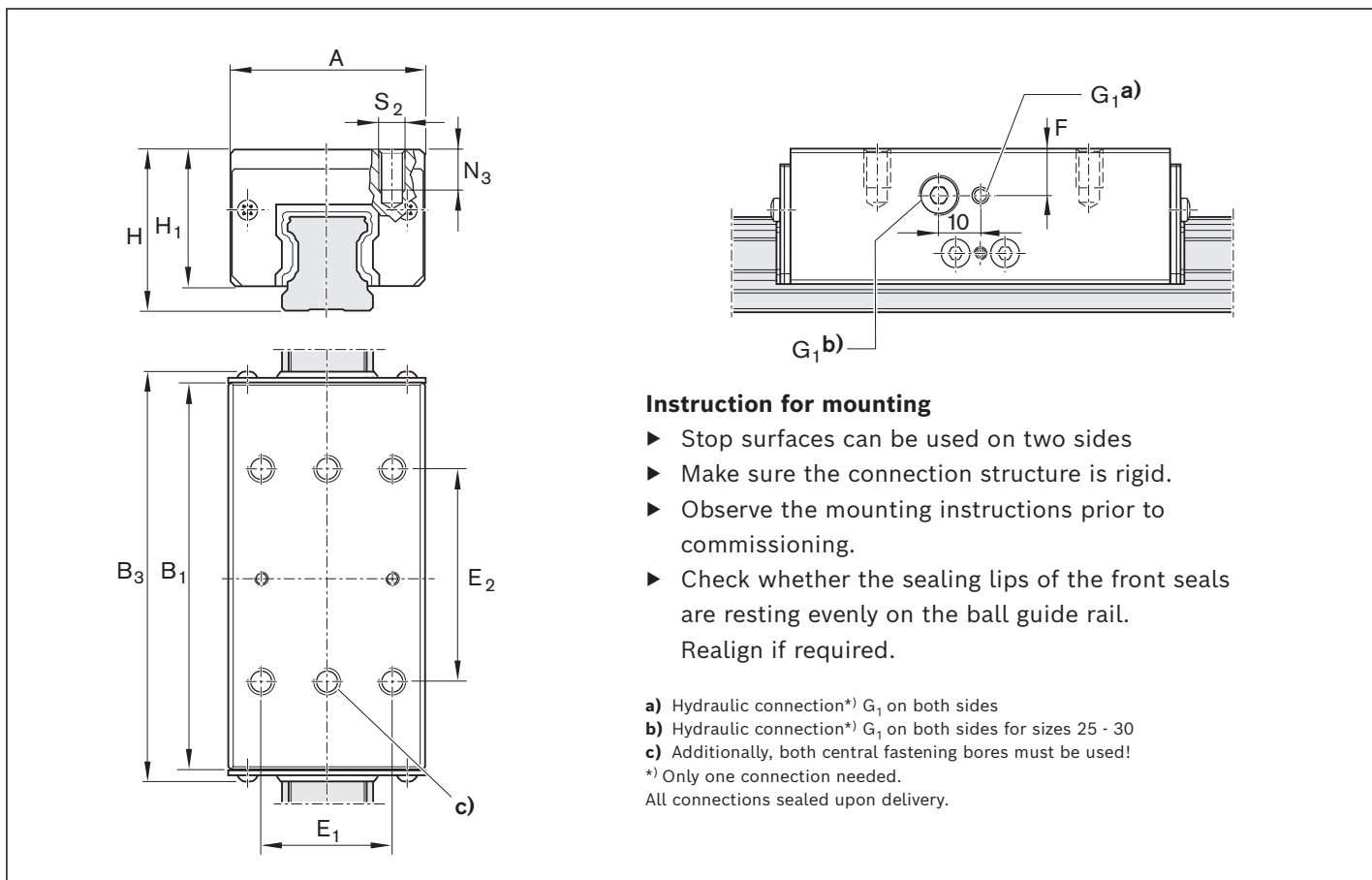

Instruction for mounting

- ▶ Stop surfaces can be used on two sides
- ▶ Make sure the connection structure is rigid.
- ▶ Observe the mounting instructions prior to commissioning.
- ▶ Check whether the sealing lips of the front seals are resting evenly on the ball guide rail. Realign if required.

- a) Hydraulic connection*) G₁ on both sides
 - b) Hydraulic connection*) G₁ on both sides for sizes 25 - 30
 - c) Additionally, both central fastening bores must be used!
- *) Only one connection needed.
All connections sealed upon delivery.

Size	Material number	Holding force ¹⁾ (N)	Dimensions (mm)											Displacement ⁴⁾ (cm ³)	Mass (kg)
			A	B ₁	B _{3 max}	H	H ₁	E ₁	E ₂	F	G ₁	N ₃	S ₂		
25	R1619 242 31	1600 ²⁾	48	92.0	102.3	40	33.5	35	50	12	1/8"	12	M6	0.6	1.10
30	R1619 742 31	3000 ²⁾	60	103.5	115.4	45	38.0	40	60	12	1/8"	11	M8	0.7	1.90
35	R1619 342 31	3500 ²⁾	70	120.5	134.0	55	47.0	50	72	18	1/8"	13	M8	1.1	2.46
45	R1619 442 31	7400 ²⁾	86	155.0	170.0	70	60.0	60	80	24	1/8"	18	M10	1.8	4.95
55	R1619 542 31	13700 ³⁾	100	184.0	201.0	80	67.0	75	95	26	1/8"	19	M12	2.4	7.90

1) The inspection is done in a mounted state with a lubricated layer (ISO-VG 68). Permissible holding force 173
 2) At 100 bar
 3) At 150 bar
 4) Per clamping

Pneumatic clamping and braking units, product description

Application areas

Clamping

- ▶ In the event of loss of pressure
- ▶ During assembly work and standstill of the machine without energy
- ▶ Of machine tables from machining centers
- ▶ Of z-axis positioning in the resting position

Brakes

- ▶ In the event of energy failure
- ▶ In the event of a pressure drop
- ▶ Support of the emergency stop function
- ▶ Support as brake for linear motors

Characteristic features

- ▶ Clamps and brakes with spring energy accumulator
- ▶ Positive-locking integrated contact profiles ensure maximum axial and horizontal rigidity, and thus an excellent braking effect
- ▶ Dynamic and static stability in axial direction

Special features MBPS/UBPS:

- ▶ 5 million clamping cycles (B10d value)

⚠ Observe the safety instructions on clamping and braking units.

Functional principle

Air pressure: 0 bar

Clamps and brakes with spring force

In the event of a pressure drop, the clamping or braking effect is generated via a dual acting gate valve gear mechanism, each with one spring assembly (spring energy accumulator).

An integrated quick-exhaust valve ensures short response times.

Air pressure: 4.5 - 8 bar (MBPS)

5.5 - 8 bar (UBPS)

Decompression with air pressure

The clamping profiles are held apart by the compressed air.

- ▶ Free movement is possible

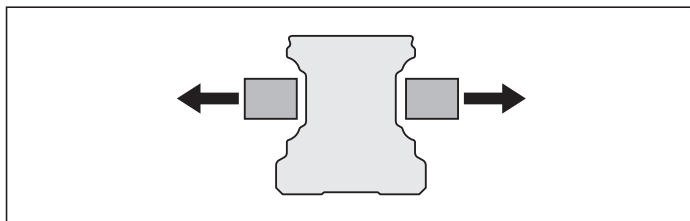
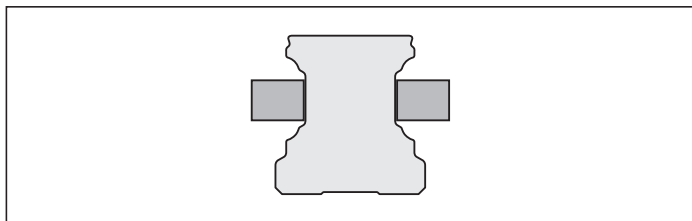

Further highlights

- ▶ Up to 1 million clamping cycles
- ▶ Up to 2000 emergency braking operations
- ▶ Integrated all-round sealing
- ▶ High continuous output
- ▶ High positioning accuracy
- ▶ Mechanical gate valve gear mechanism
- ▶ Solid, rigid steel housing, chemically nickel-plated
- ▶ Low air consumption
- ▶ Maintenance-free

Special features of MBPS:

- ▶ Clamping and braking units in short format
- ▶ Add-ons with three pistons connected in series combined with strong springs result in holding forces up to 3,800 N at just 4.5 bar release pressure
- ▶ 5 million clamping cycles (B10d value)¹⁾

Special features of UBPS:

- ▶ Very high axial holding forces of up to 7700 N at 5.5 bar release pressure with high-power spring energy accumulator
- ▶ Increased holding force of up to 9200 N thanks to additional pressurization on the air-plus port
- ▶ Extremely low air consumption
- ▶ Compact design, compatible with DIN 645
- ▶ 5 million clamping cycles (B10d value)¹⁾

1) B10d value is not achieved on air-plus port

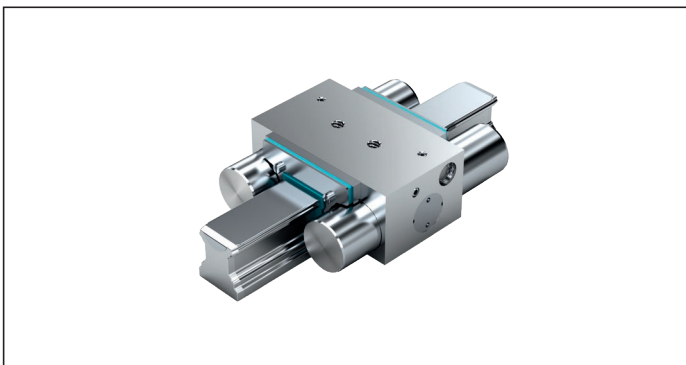
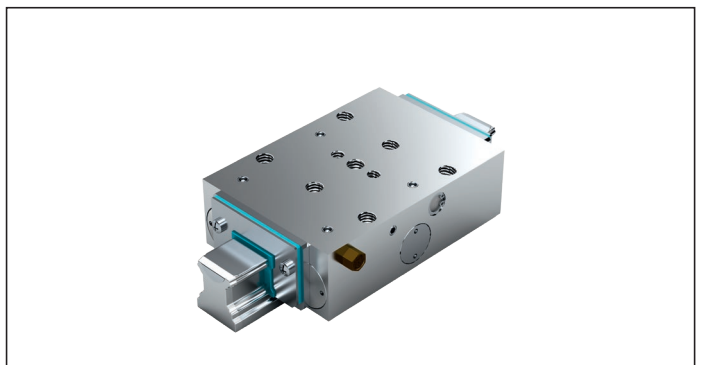
MBPS**UBPS**

Pneumatic clamping and braking units MBPS

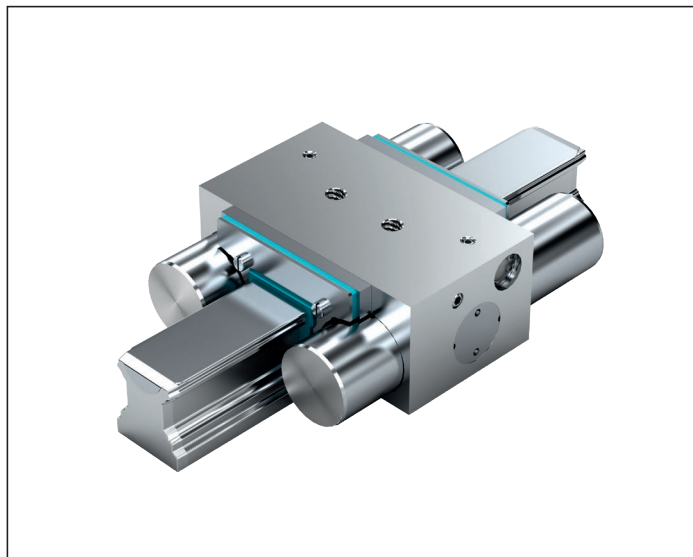

R1619 .40 31

Note

Can be used on all ball guide rails SNS.

Clamps and brakes without pressurization (spring energy)

- ▶ Minimum release pressure 4.5 bar
- ▶ Maximum pneumatic operating pressure: 8 bar
- ▶ Operating temperature range t: 0 – 70°C

Instruction for mounting

- ▶ Make sure the connection structure is rigid.
- ▶ Use only purified and lubricated air. The prescribed filter mesh size is 25 µm.
- ▶ Observe the mounting instructions prior to commissioning.
- ▶ Check whether the sealing lips of the front seals are resting evenly on the ball guide rail. Realign if required.

⚠ Observe the safety instructions on clamping and braking units.

Circuitry¹⁾ for standard air port

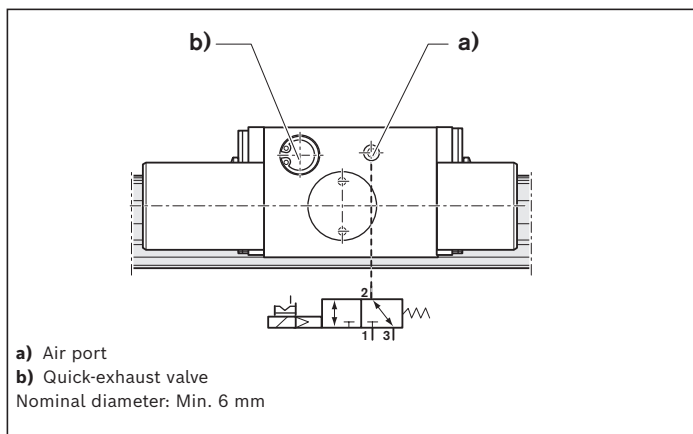

Size	Material number	Holding force Spring energy ¹⁾ (N)	Air consumption (normal liter) Air port (dm ³ /stroke)
20	R1619 840 31	1000	0.034
25	R1619 240 31	1300	0.048
30	R1619 740 31	2000	0.065
35	R1619 340 31	2600	0.093
45	R1619 440 31	3600	0.099
55	R1619 540 31	4700	0.244
65	R1619 640 31	4700	0.244

1) Holding force by spring energy at 6 bar. The inspection is done in a mounted state with a lubricated layer (ISO-VG 68).

MBPS

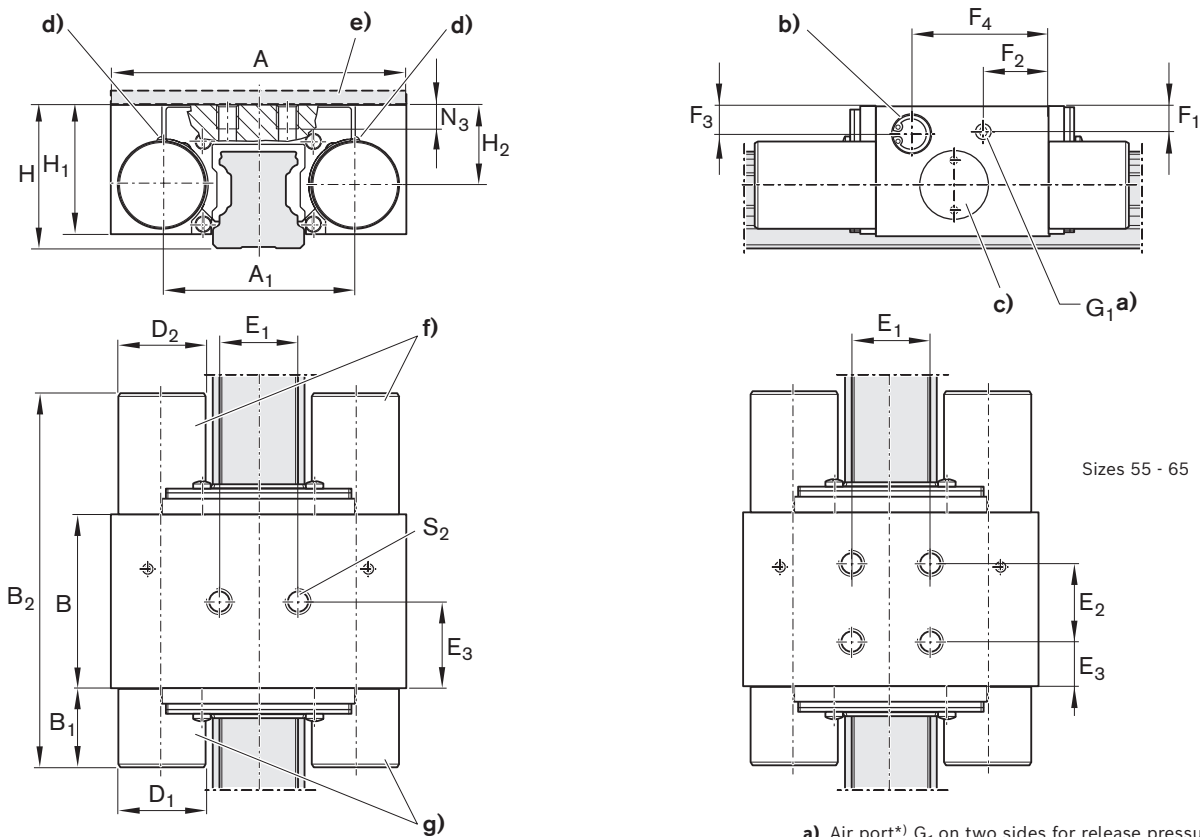

- a) Air port*) G₁ on two sides for release pressure
 - b) Quick-exhaust on two sides
 - c) Adjusting screw on two sides
 - d) Exhaust on two sides
 - e) Spacer plate (accessory)
 - f) Piston
 - g) Spring-loaded accumulator
- *) Only one connection needed.
All connections sealed upon delivery.

Size	Dimensions (mm)																				Mass (kg)
	A	A ₁	B	B ₁	B _{2 max}	D ₁	D ₂	E ₁	E ₂	E ₃	F ₁	F ₂	F ₃	F ₄	G ₁	H	H ₁ ¹⁾	H ₂	N ₃	S ₂	
20	66	45.7	44	19.0	94.5	16	18	20	-	22.0	5.5	15.5	6.0	35.5	M5	30	25.8	16.2	8.6	M6	0.7
25	75	49.0	44	20.2	95.5	22	22	20	-	22.0	6.5	16.5	7.0	34.7	M5	36	32.5	20.0	8.0	M6	1.0
30	90	58.0	47	29.0	107.5	25	25	22	-	23.0	7.2	30.5	7.2	40.0	M5	42	38.5	24.0	9.0	M8	1.8
35	100	68.0	46	27.7	106.2	28	28	24	-	24.5	9.0	19.0	9.5	38.0	G1/8"	48	42.0	26.5	10.0	M8	1.9
45	120	78.8	49	32.2	113.7	30	30	26	-	24.5	15.0	31.1	12.2	41.6	G1/8"	60	52.0	35.5	15.0	M10	2.3
55	140	97.0	62	41.0	145.0	39	39	38	38	12.0	11.0	23.0	11.0	40.0	M5	70	59.0	38.0	18.0	M10	3.7
65	150	106.0	62	41.0	145.0	39	38	38	38	12.0	16.0	23.0	16.0	40.0	M5	90	75.5	53.5	18.0	M10	4.2

1) For ball runner block .H. (...high...) Spacer plate necessary.

Pneumatic clamping and braking units UBPS

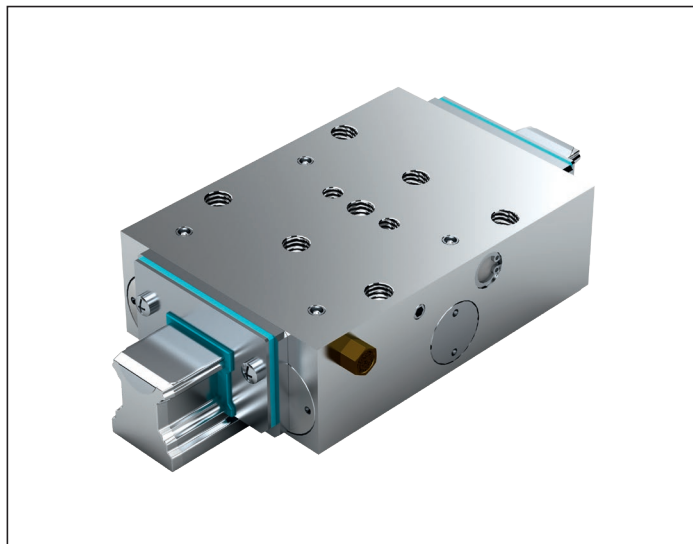

R1619 .40 51

Very high axial holding forces due to three pistons connected in series combined with strong spring energy accumulator; increased holding force thanks to additional pressure through the air-plus port.

Note

Can be used on all ball guide rails SNS.

Clamps and brakes without pressurization (spring energy)

- ▶ Minimum release pressure 5.5 bar
- ▶ Maximum pneumatic operating pressure: 8 bar
- ▶ Operating temperature range t: 0 - 70 °C

Instruction for mounting

- ▶ Stop surfaces can be used on two sides.
- ▶ Make sure the connection structure is rigid.
- ▶ Use only purified and lubricated air. The prescribed filter mesh size is 25 µm.
- ▶ Observe the mounting instructions prior to commissioning.
- ▶ Check whether the sealing lips of the front seals are resting evenly on the ball guide rail. Realign if required.

⚠ Observe the safety instructions on clamping and braking units.

Circuitry¹⁾ for standard air port

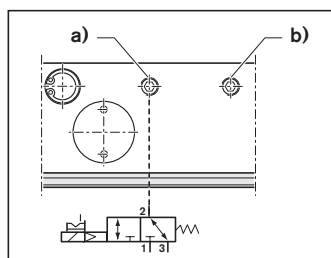

a) Air port
b) Air filter
Nominal diameter: Min. 6 mm

Circuitry²⁾ for air-plus port

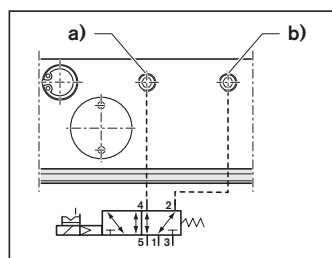

a) Air port
b) Air-plus port
Nominal diameter: Min. 6 mm

Size	Material number	Holding force Spring energy ¹⁾ (N)	Air consumption (normal liter)	
			with air-plus port ²⁾ (N)	Air port Air-plus port (dm ³ /stroke)
25	R1619 240 51	1500	2650	0.080 / 0.165
30	R1619 740 51	2500	3300	0.111 / 0.274
35	R1619 340 51	2800	3800	0.139 / 0.303
45	R1619 440 51	5200	7600	0.153 / 0.483
55	R1619 540 51	7700	9200	0.554 / 0.952

1) Holding force achieved by spring energy. The inspection is done in a mounted state with a lubricated layer (ISO-VG 68).
2) Increased holding force by additional air admission at air-plus port with 6.0 bar. Switching via 5/2 or 5/3-way directional control valve.

UBPS

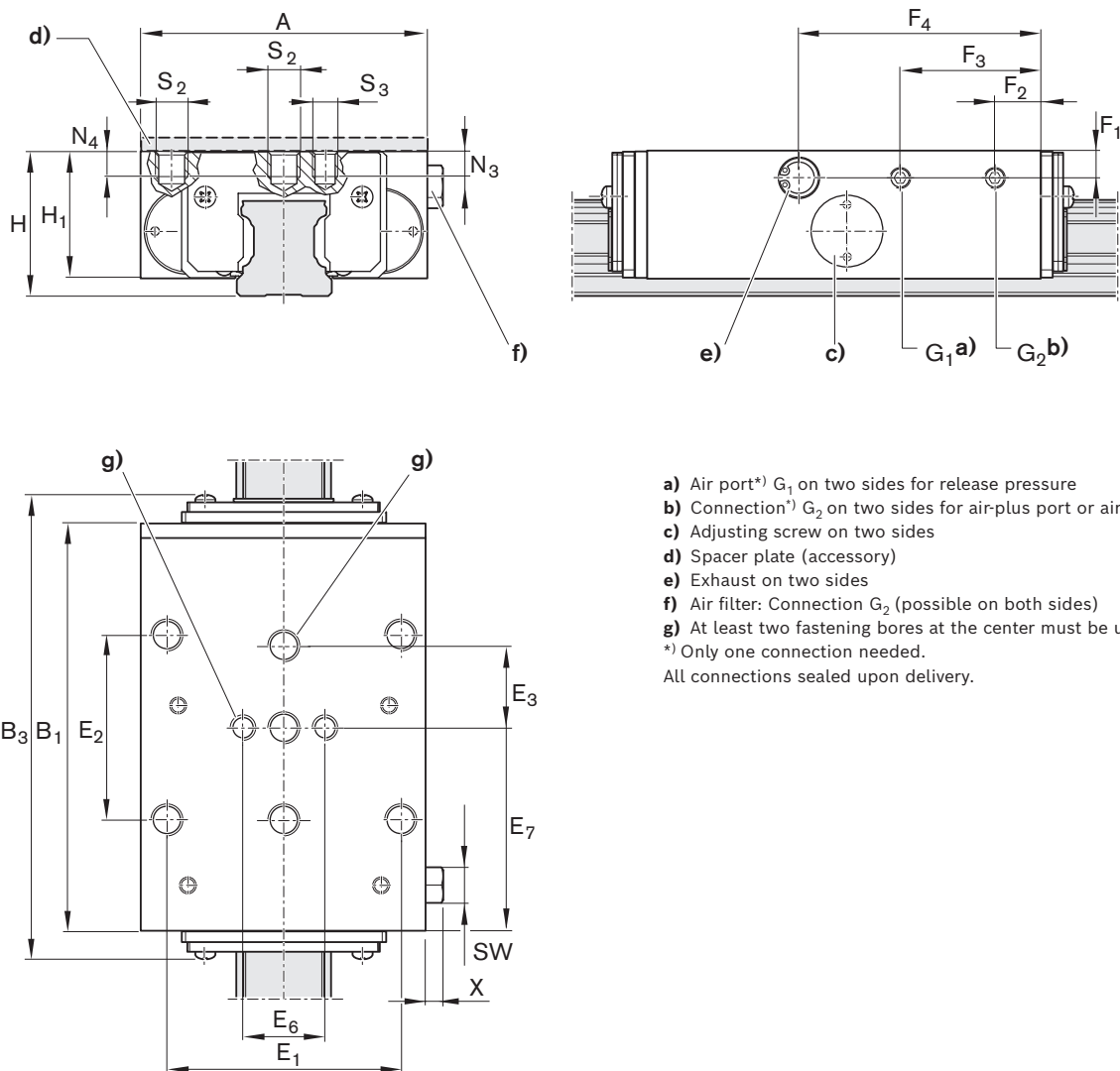

- a) Air port*) G₁ on two sides for release pressure
 - b) Connection¹⁾ G₂ on two sides for air-plus port or air filter
 - c) Adjusting screw on two sides
 - d) Spacer plate (accessory)
 - e) Exhaust on two sides
 - f) Air filter: Connection G₂ (possible on both sides)
 - g) At least two fastening bores at the center must be used!
- *) Only one connection needed.
All connections sealed upon delivery.

Size	Dimensions (mm)											
	A	B ₁	B _{3 max}	E ₁	E ₂	E ₃	E ₆	E ₇	F ₁	F ₂	F ₃	F ₄
25	70	99	115.1	57	45	20	20	49.5	6.5	11	34.3	59.0
30	90	109	128.7	72	52	22	22	54.5	6.5	11	40.8	66.5
35	100	109	131.0	82	62	26	24	54.5	8.0	11	40.8	66.5
45	120	197	220.1	100	80	30	-	98.5	12	32	167	106.5
55	140	197	221.6	116	95	35	-	98.5	13	32	165	103.5

Size	Dimensions (mm)										Mass (kg)
	G ₁	G ₂	H	H ₁ ¹⁾	N ₃	N ₄	S ₂	S ₃	X	SW	
25	M5	M5	36	31	7	7	M8	M6	5.5	Ø8, SW7	1.20
30	M5	M5	42	37	8	8	M10	M8	5.5	Ø8, SW7	1.80
35	G1/8"	G1/8"	48	42	10	10	M10	M8	6.5	Ø15, SW13	2.25
45	G1/8"	G1/8"	60	52	-	12	M12	-	6.5	Ø15, SW13	6.20
55	G1/8"	G1/8"	70	60	-	14	M14	-	6.5	Ø15, SW13	9.40

1) For ball runner block .H. (...high...) Spacer plate necessary. Available on request.

Product description pneumatic clamping units

Application areas

- ▶ Pneumatic clamping of machine axes
- ▶ Table crossbars in the timber industry
- ▶ Positioning of lifting gear

Characteristic features

- ▶ High axial holding forces with short format
- ▶ Dynamic and static stability in axial direction
- ▶ Simple mechanical gripping principle in LCP and LCPS with good price/performance ratio

Further highlights

- ▶ Easy mounting
- ▶ Chemically nickel-plated steel housing
- ▶ High axial and horizontal rigidity
- ▶ Precise positioning

▲ Observe the safety instructions on clamping and braking units.

Special features of MK:

- ▶ Clamps with compression (pneumatic). The clamping profiles are pressed by compressed air onto the web surfaces of the ball guide rail via a dual acting gate valve gear mechanism.
- ▶ Continuously adjustable pressure from 4 - 8 bar
- ▶ Decompression with spring force. A preloaded return spring allows for short decompression cycles.
- ▶ 5 million clamping cycles (B10d value)

Special features of MKS:

- ▶ Clamps without pressurization (spring energy). In the event of a pressure drop, it clamps via the dual-action gate valve gear mechanism with two spring assemblies.
- ▶ An integrated quick-exhaust valve ensures short response times.
- ▶ Higher holding force due to the air-plus port
- ▶ Pneumatic decompression Release pressure 5.5 - 8 bar
- ▶ 5 million clamping cycles (B10d value) *)

Special features of LCP:

- ▶ Clamps with compression (pneumatic) by means of mechanical gripping
- ▶ Continuously adjustable pressure from 5.5 - 8 bar
- ▶ Short decompression cycles
- ▶ Decompression with spring force. A preloaded return spring allows for short decompression cycles.

Special features of LCPS:

- ▶ Clamps without pressurization (with spring energy) by means of mechanical gripping with a spring assembly (spring energy accumulator)
- ▶ Release pressure 5.5 - 8 bar (pneumatic)
- ▶ Higher holding force due to the air-plus port
- ▶ Decompression with air pressure.

*) with the air-plus port, the B10d value cannot be achieved.

Functional principle

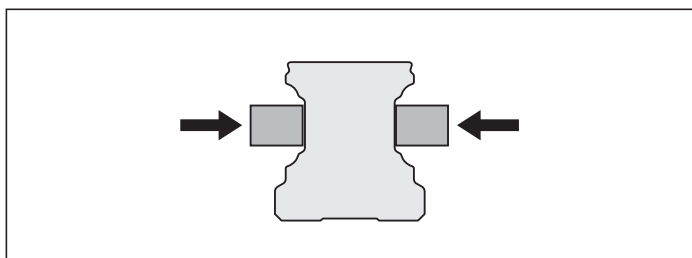

Clamping with air pressure or spring force

- ▶ The clamping profiles are pressed to the web surfaces of the ball guide rail.

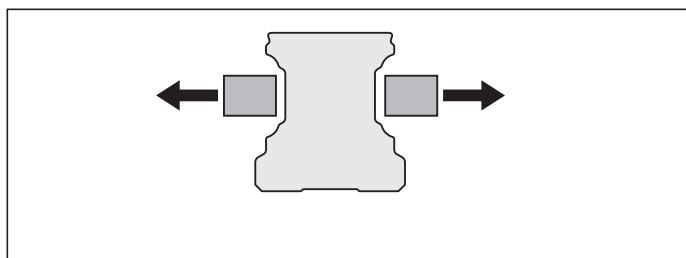

Decompression with air pressure or spring force

- ▶ The clamping profiles are held apart.
- ▶ Free movement is possible.

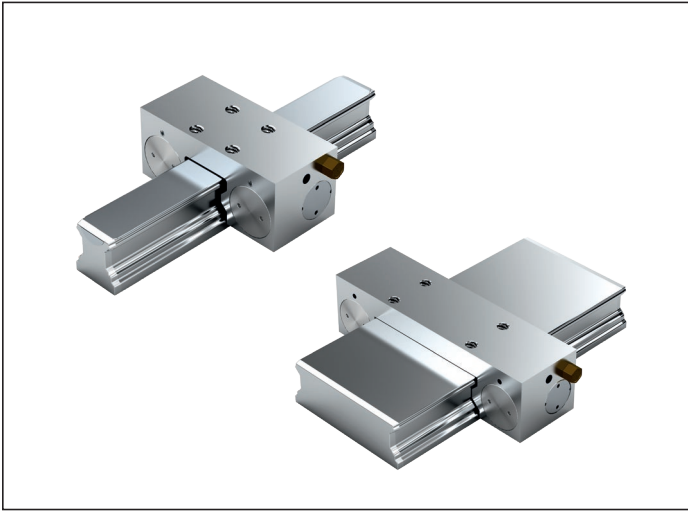
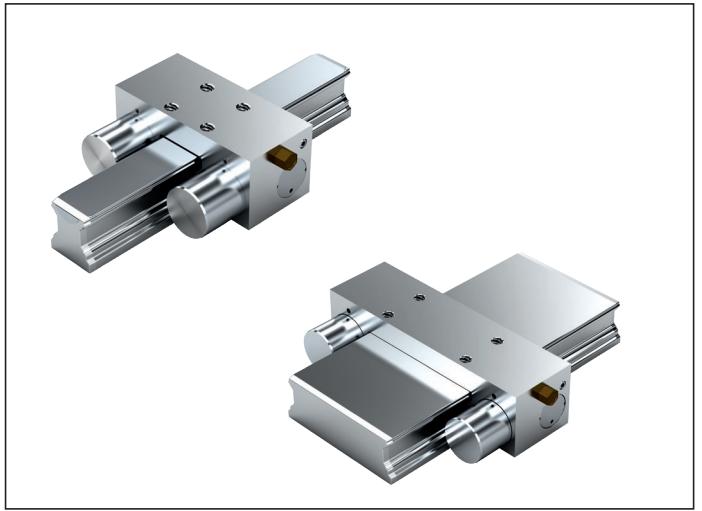
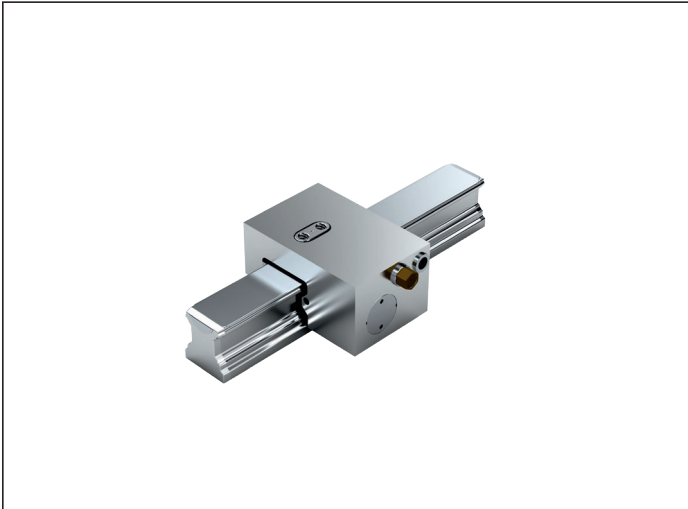
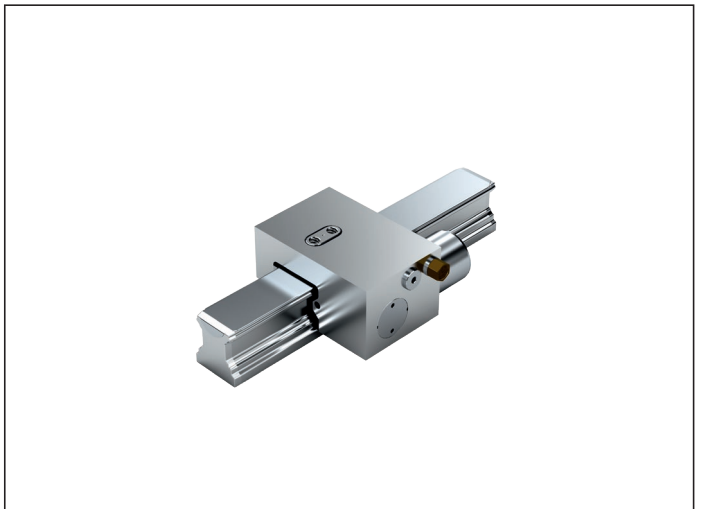
Model overview of accessories for pneumatic clamping units**MK****MKS****LCP****LCPS**

Pneumatic clamping units MK

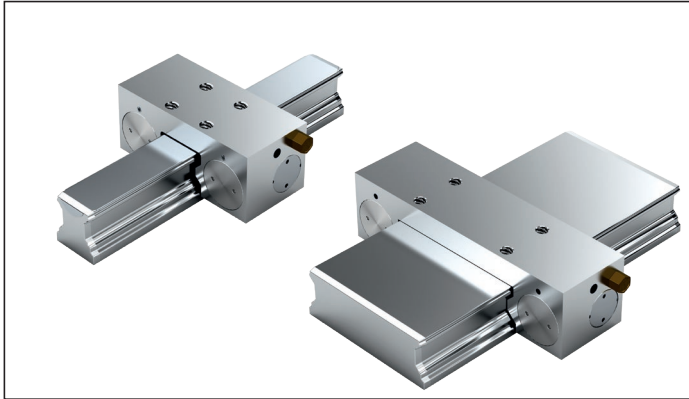

R1619 .42 60

Note

Can be used on all ball guide rails SNS.

R1619 .42 62

Note

Can be used on all ball guide rails BNS.

Clamps with compression

- ▶ Maximum pneumatic operating pressure: 8 bar
- ▶ Operating temperature range t: 0 – 70°C

Instruction for mounting

- ▶ Make sure the connection structure is rigid.
- ▶ Use only purified and lubricated air. The prescribed filter mesh size is 25 µm.
- ▶ Observe the mounting instructions prior to commissioning.

⚠ Observe the safety instructions on clamping and braking units.

**Circuit type¹⁾
for standard air port**

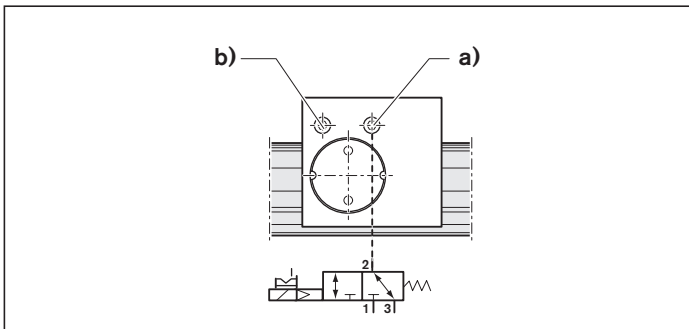

- a) Air port
- b) Air filter

Nominal diameter:

Sizes 15 - 20: min. 4 mm

Sizes 25 - 65: min. 6 mm

Size	Material number	Holding force pneumatic ¹⁾ (N)	Air consumption (normal liter) Air port (dm ³ /stroke)
15	R1619 142 60	650	0.011
20	R1619 842 60	1000	0.019
25	R1619 242 60	1200	0.021
30	R1619 742 60	1750	0.031
35	R1619 342 60	2000	0.031
45	R1619 442 60	2250	0.041
55	R1619 542 60	2250	0.041
65	R1619 642 60	2250	0.041
20/40	R1619 842 62	650	0.019
25/70	R1619 242 62	1200	0.021
35/90	R1619 342 62	2000	0.031

1) Holding force at 6 bar. The inspection is done in a mounted state with a lubricated layer (ISO-VG 68).

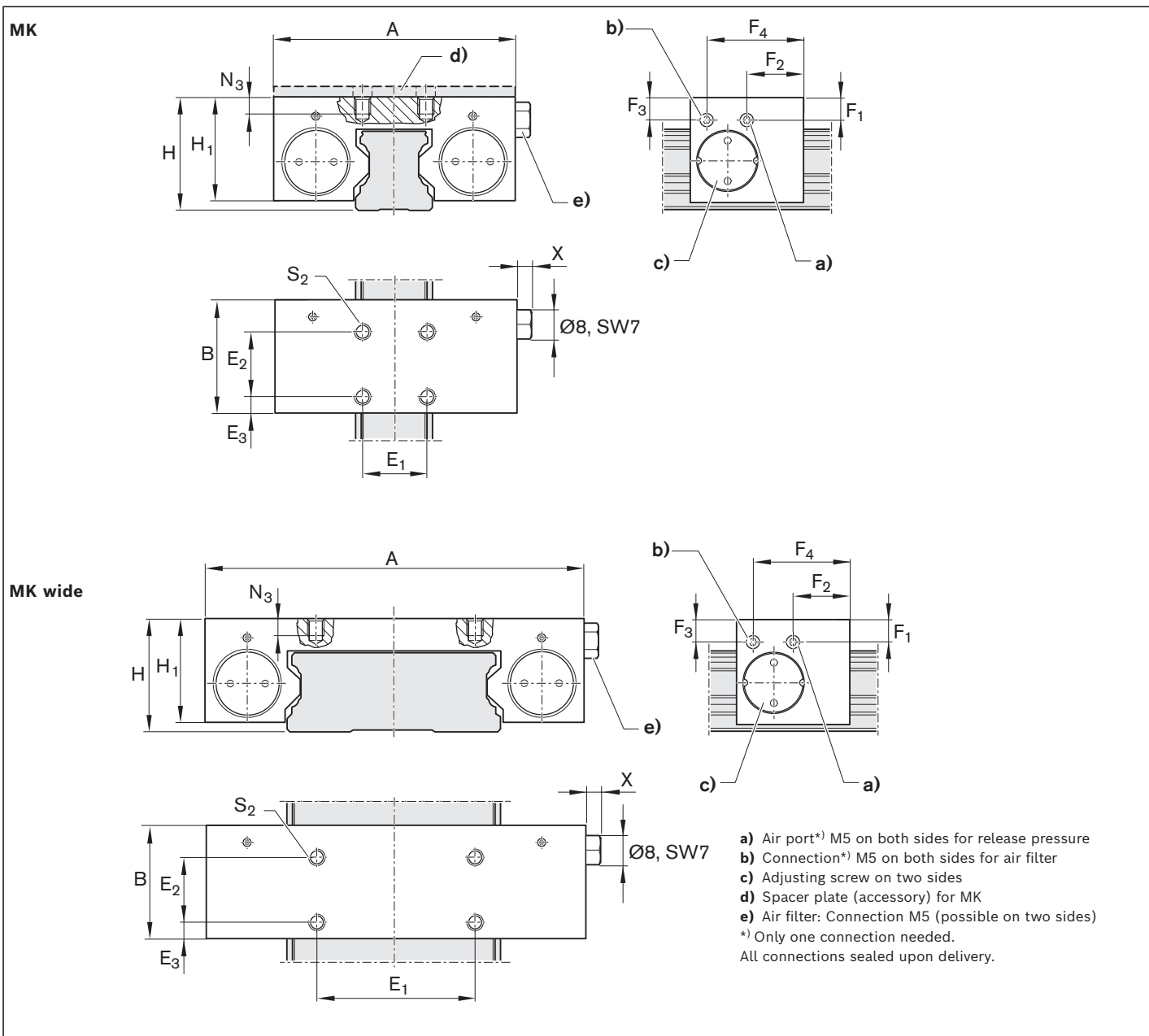

Size	Dimensions (mm)													Mass (kg)	
	A	B	E ₁	E ₂	E ₃	F ₁	F ₂	F ₃	F ₄	H	H ₁ ¹⁾	N ₃	S ₂		X
15	55	39	15	15	15.5	5.6	34.0	16.1	34.0	24	20.8	4.5	M4	6.5	0.25
20	66	39	20	20	9.0	4.5	17.3	6.0	34.5	30	27.0	6.0	M6	5.5	0.36
25	75	35	20	20	5.0	7.0	17.5	7.0	30.0	36	32.5	8.0	M6	5.5	0.45
30	90	39	22	22	8.5	8.5	15.0	10.3	24.5	42	38.5	9.0	M8	5.5	0.72
35	100	39	24	24	7.5	11.0	14.5	12.0	24.5	48	44.0	10.0	M8	5.5	0.88
45	120	49	26	26	11.5	14.5	19.5	14.5	29.5	60	52.0	15.0	M10	5.5	1.70
55	128	49	30	30	9.5	17.0	19.5	17.0	29.5	70	57.0	15.0	M10	5.5	1.95
65	138	49	30	30	9.5	14.5	19.5	14.5	29.5	90	73.5	20.0	M10	5.5	2.68
20/40	80	39	20	20	15.5	5.0	4.5	5.0	31.0	27	23.5	4.5	M4	5.5	0.37
25/70	120	35	50	20	5.0	7.0	17.5	9.0	30.0	35	32.5	8.0	M6	5.5	0.62
35/90	156	42	60	20	9.5	11.5	18.0	14.0	36.5	50	45.5	10.0	M10	5.5	0.88

1) For ball runner block .H. (...high...) Spacer plate necessary

Pneumatic clamping units MKS

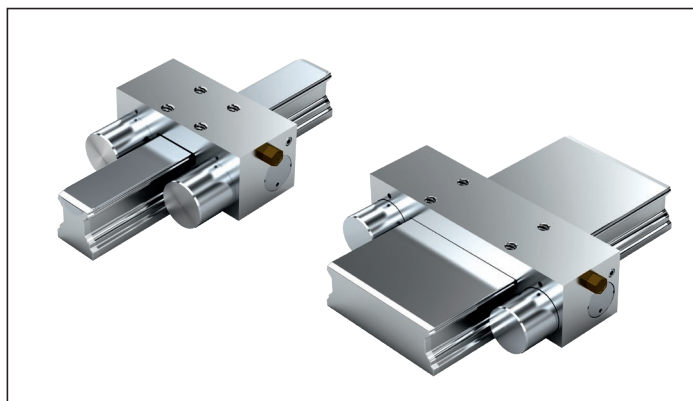

R1619 .40 60

Note

Can be used on all ball guide rails SNS.

R1619 .40 62

Note

Can be used on all ball guide rails BNS.

Clamps without pressurization (spring energy)

- ▶ Minimum release pressure 5.5 bar
- ▶ Maximum pneumatic operating pressure: 8 bar
- ▶ Operating temperature range t: 0 – 70°C

Circuit type¹⁾ for standard air port

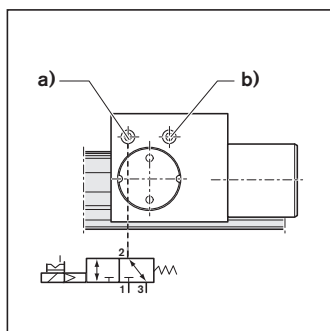

a) Air port
b) Air filter
Nominal diameter:
Sizes 15 - 20: min. 4 mm
Sizes 25 - 65: min. 6 mm

Circuit type²⁾ for air-plus port

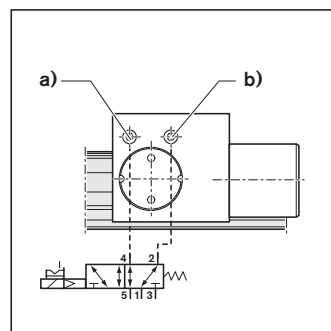

a) Air port
b) Air-plus port
Nominal diameter:
Sizes 15 - 20: min. 4 mm
Sizes 25 - 65: min. 6 mm

Instruction for mounting

- ▶ Make sure the connection structure is rigid.
- ▶ Use only purified and lubricated air. The prescribed filter mesh size is 25 µm.
- ▶ Observe the mounting instructions prior to commissioning.

⚠ Observe the safety instructions on clamping and braking units.

Size	Material number	Holding force		Air consumption (normal liter)	
		Spring energy ¹⁾ (N)	with air-plus port ²⁾ (N)	Air port (dm ³ /stroke)	Air-plus port (dm ³ /stroke)
15	R1619 140 60	400	1050	0.011	0.035
20	R1619 840 60	600	1300	0.019	0.063
25	R1619 240 60	750	1500	0.021	0.068
30	R1619 740 60	1050	2200	0.031	0.121
35	R1619 340 60	1250	2200	0.031	0.129
45	R1619 440 60	1450	3300	0.041	0.175
55	R1619 540 60	1450	3300	0.041	0.175
65	R1619 640 60	1450	3300	0.041	0.175
20/40	R1619 840 62	400	1050	0.019	0.063
25/70	R1619 240 62	750	1950	0.021	0.068
35/90	R1619 340 62	1250	2200	0.031	0.129

1) Holding force achieved by spring energy. The inspection is done in a mounted state with a lubricated layer (ISO-VG 68).

2) Increased holding force by additional air admission at air-plus port with 6.0 bar. Switching via 5/2 or 5/3-way directional control valve.

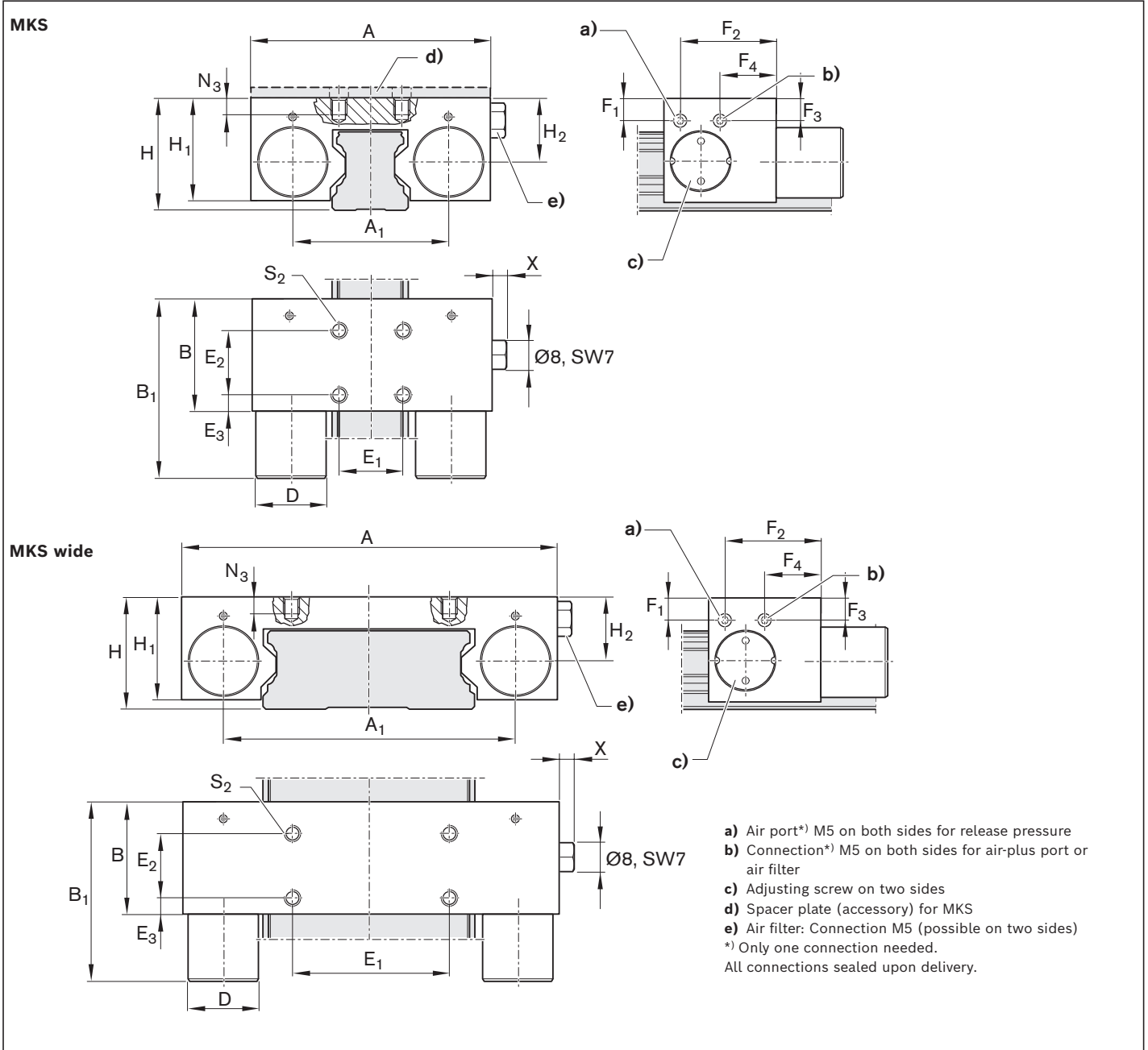

Size	Dimensions (mm)																Mass (kg)		
	A	A ₁	B	B _{1max}	D	E ₁	E ₂	E ₃	F ₁	F ₂	F ₃	F ₄	H	H ₁ ¹⁾	H ₂	N ₃		S ₂	X
15	55	34.0	39	58.5	16	15	15	15.5	16.1	34.0	5.6	34.0	24	20.8	11.6	4.5	M4	6.5	0.29
20	66	43.0	39	61.5	20	20	20	9.0	6.0	34.5	4.5	17.3	30	27.0	15.5	6.0	M6	5.5	0.41
25	75	49.0	35	56.5	22	20	20	5.0	7.0	30.0	7.0	17.5	36	32.5	20.0	8.0	M6	5.5	0.50
30	90	58.0	39	68.5	25	22	22	8.5	10.3	24.5	8.5	15.0	42	38.5	24.0	9.0	M8	5.5	0.81
35	100	68.0	39	67.5	28	24	24	7.5	12.0	24.5	11.0	14.5	48	44.0	28.0	10.0	M8	5.5	1.00
45	120	78.8	49	82.5	30	26	26	11.5	14.5	29.5	14.5	19.5	60	52.0	35.5	15.0	M10	5.5	1.84
55	128	86.8	49	82.5	30	30	30	9.5	17.0	29.5	17.0	19.5	70	57.0	40.0	15.0	M10	5.5	2.08
65	138	96.8	49	82.5	30	30	30	9.5	14.5	29.5	14.5	19.5	90	73.5	55.0	20.0	M10	5.5	2.86
20/40	80	59.0	39	58.5	16	20	20	15.5	5.0	31.0	5.0	4.5	27	23.5	14.0	4.5	M4	5.5	0.39
25/70	120	94.0	35	56.5	22	50	20	5.0	9.0	30.0	7.0	17.5	35	32.5	20.0	8.0	M6	5.5	0.68
35/90	156	124.0	42	70.5	28	60	20	9.5	14.0	36.5	11.5	18.0	50	45.5	30.0	10.0	M10	5.5	0.89

1) For ball runner block .H. (...high...) Spacer plate necessary

Pneumatic clamping units LCP



R1619 .42 74

Note

Can be used on all ball guide rails SNS.

Clamps with compression

- ▶ Maximum pneumatic operating pressure: 8 bar
- ▶ Operating temperature range t: 0 – 60 °C

Instruction for mounting

- ▶ Make sure the connection structure is rigid.
- ▶ Use only purified and lubricated air. The prescribed filter mesh size is 25 µm.
- ▶ Observe the mounting instructions prior to commissioning.

⚠ Observe the safety instructions on clamping and braking units.

**Circuit type¹⁾
for standard air port**

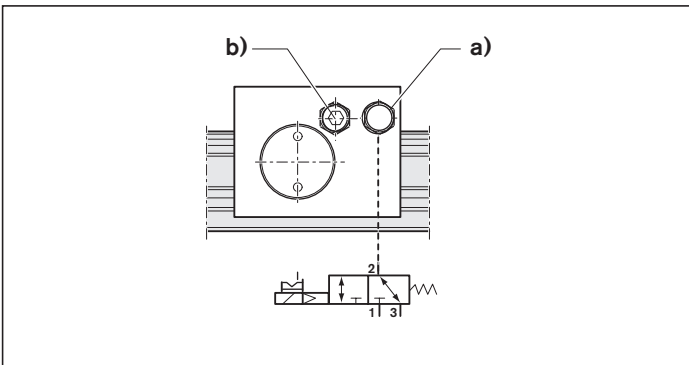

- a) Air port
- b) Air filter

Nominal diameter:

Sizes 15 - 20: min. 4 mm

Sizes 25 - 65: min. 6 mm

Size	Material number	Holding force pneumatic ¹⁾ (N)	Air consumption (normal liter) Air port (dm ³ /stroke)
25	R1619 242 74	850	0.015

1) Holding force at 6 bar. The inspection is done in a mounted state with a lubricated layer (ISO-VG 68).

LCP

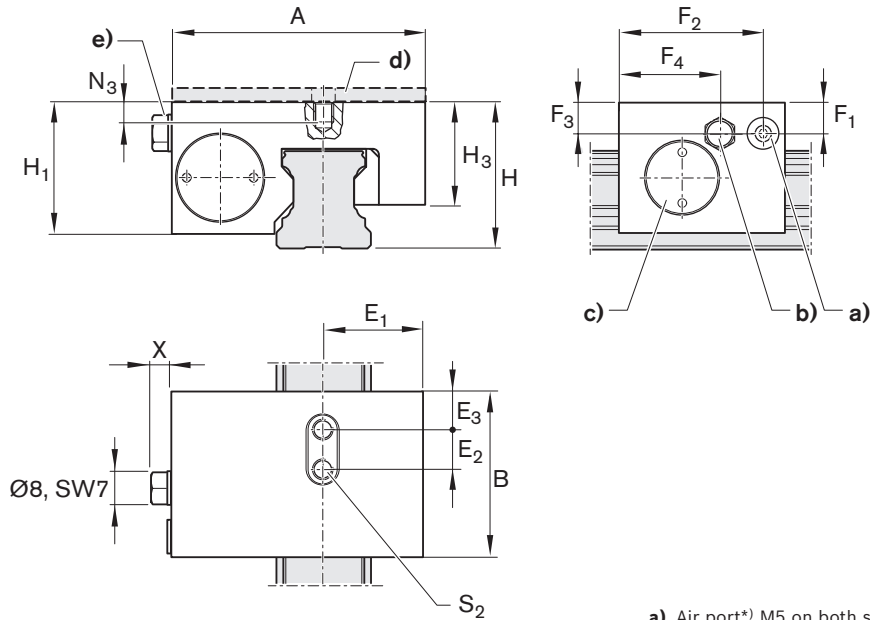

- a) Air port^{*)} M5 on both sides for release pressure
 - b) Connection^{*)} M5 on both sides for air filter
 - c) Adjusting screw on two sides
 - d) Spacer plate (accessory)
 - e) Air filter: Connection M5 (possible on two sides)
- ^{*)} Only one connection needed.
All connections sealed upon delivery.

Size	Dimensions (mm)															Mass (kg)
	A	B	E ₁	E ₂	E ₃	F ₁	F ₂	F ₃	F ₄	H	H ₁ ¹⁾	H ₃	N ₃	S ₂	X	
25	61.4	41	23.9	9.5	9.75	6.5	36.0	6.5	24.5	36.0	32.5	24.55	7.7	M5	6.5	0.27

1) For ball runner block .H. (...high...) Spacer plate necessary.

Pneumatic clamping units LCPS

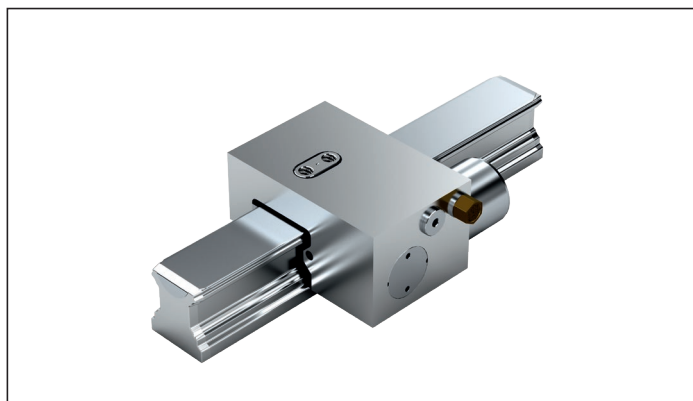

R1619 240 71

Note

Can be used on all ball guide rails SNS.

Clamps without pressurization (spring energy)

- ▶ Release pressure min.: 5.5 bar
- ▶ Maximum pneumatic operating pressure 6.5 bar
- ▶ Operating temperature range t: 0 – 60 °C

Instruction for mounting

- ▶ Make sure the connection structure is rigid.
- ▶ Use only purified and lubricated air. The prescribed filter mesh size is 25 µm.
- ▶ Observe the mounting instructions prior to commissioning.

⚠ Observe the safety instructions on clamping and braking units.

**Circuit type¹⁾
for standard air port**

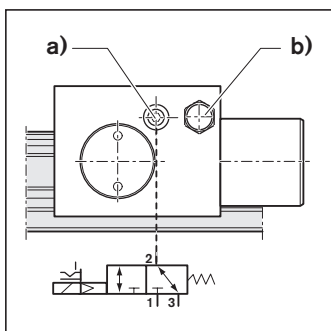

- a) Air port
- b) Air filter

Nominal diameter:
Size 25: min. 6 mm

Size	Material number	Holding force	Spring energy ¹⁾	Air consumption (normal liter)
			(N)	Air port (dm ³ /stroke)
25	R1619 240 71		600	0.015

1) Holding force achieved by spring energy. The inspection is done in a mounted state with a lubricated layer (ISO-VG 68).

LCPS

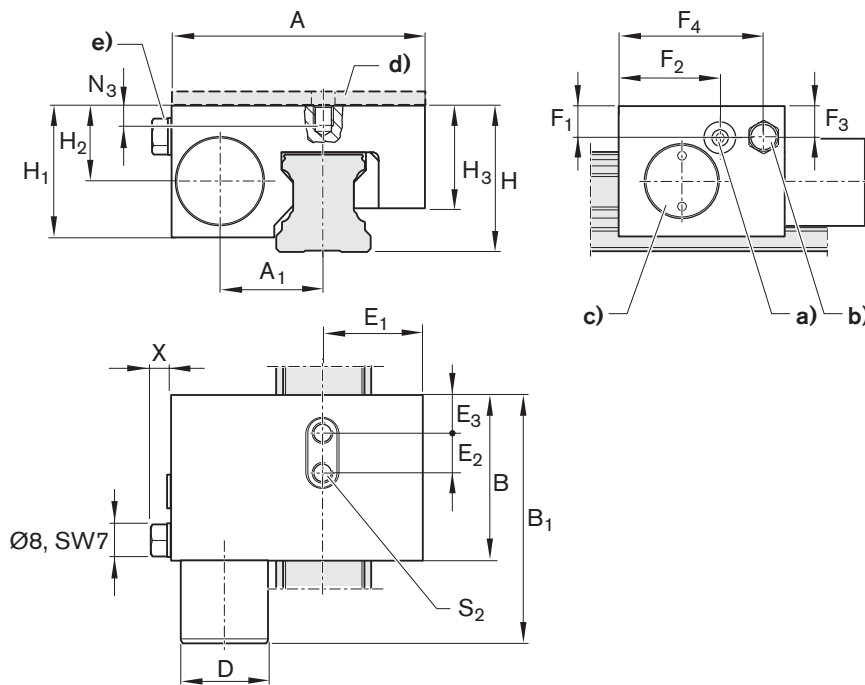

- a) Air port*) M5 on both sides for release pressure
 - b) Connection*) M5 on both sides for air filter
 - c) Adjusting screw on two sides
 - d) Spacer plate (accessory)
 - e) Air filter: Connection M5 (possible on two sides)
- *) Only one connection needed.
All connections sealed upon delivery.

Size	Dimensions (mm)																	Mass (kg)		
	A	A ₁	B	B _{1max}	D	E ₁	E ₂	E ₃	F ₁	F ₂	F ₃	F ₄	H	H ₁ ¹⁾	H ₂	H ₃	N ₃		S ₂	X
25	61.4	24.4	41	62.5	22	23	9.5	9.75	4.7	23	4.7	36.0	36	28	15.5	21	7	M5	6.5	0.37

1) For ball runner block .H. (...high...) Spacer plate necessary.

Manual clamping units, product description

Application areas

- ▶ Table crossbars and slides
- ▶ Width adjustment
- ▶ Stops
- ▶ Positioning on optical devices and measuring tables

Characteristic features

- ▶ Simple and safe structural design in compact format
- ▶ Manually operated clamping unit without auxiliary power

Special features of HK:

- ▶ 500000 clamping cycles (B10d value)

⚠ Observe the safety instructions on clamping and braking units.

Model overview of accessories for manual clamping units, spacer plate

HK

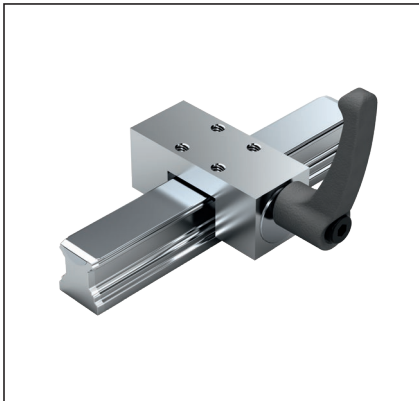

HK

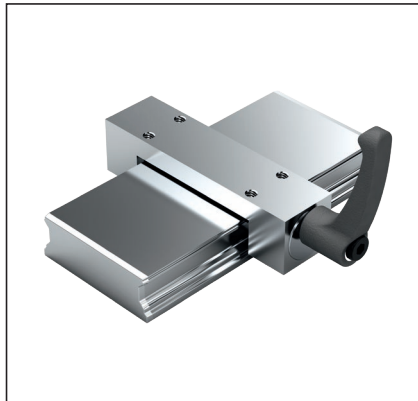

Spacer plate

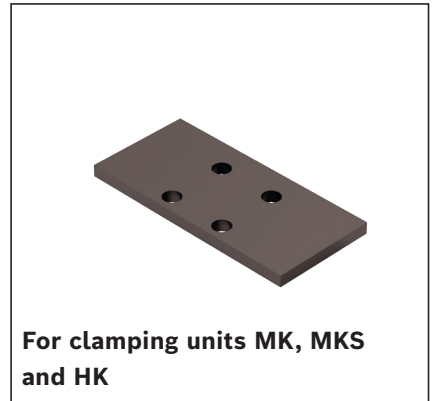

Clamps with manual compression

The clamping profiles are pressed to the web surfaces of the ball guide rail by the hand lever.

Compression via hand lever

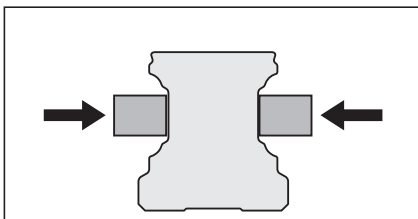

Hand lever disengaged

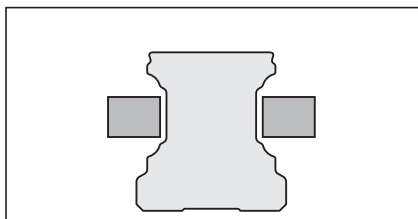

Manual clamping units HK

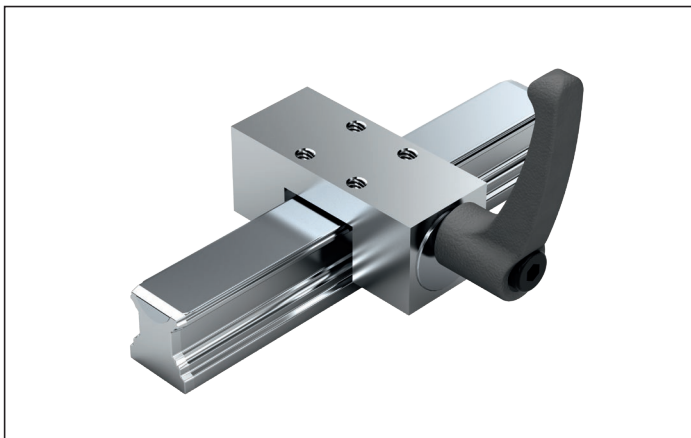

R1619 .42 82

Note

Can be used on all ball guide rails SNS.

Manual clamping unit

- ▶ Operating temperature range t: 0 – 70°C

Instruction for mounting

- ▶ Make sure the connection structure is rigid.
- ▶ Observe the mounting instructions prior to commissioning.

▲ Observe the safety instructions on clamping and braking units.

Size	Material number	Holding force ¹⁾ (N)	Tightening torque (Nm)
15	R1619 142 82	1200	4
20	R1619 842 82	1200	5
25	R1619 242 82	1200	7
30	R1619 742 82	2000	15
35	R1619 342 82	2000	15
45	R1619 442 82	2000	15
55	R1619 542 82	2000	22
65	R1619 642 82	2000	22

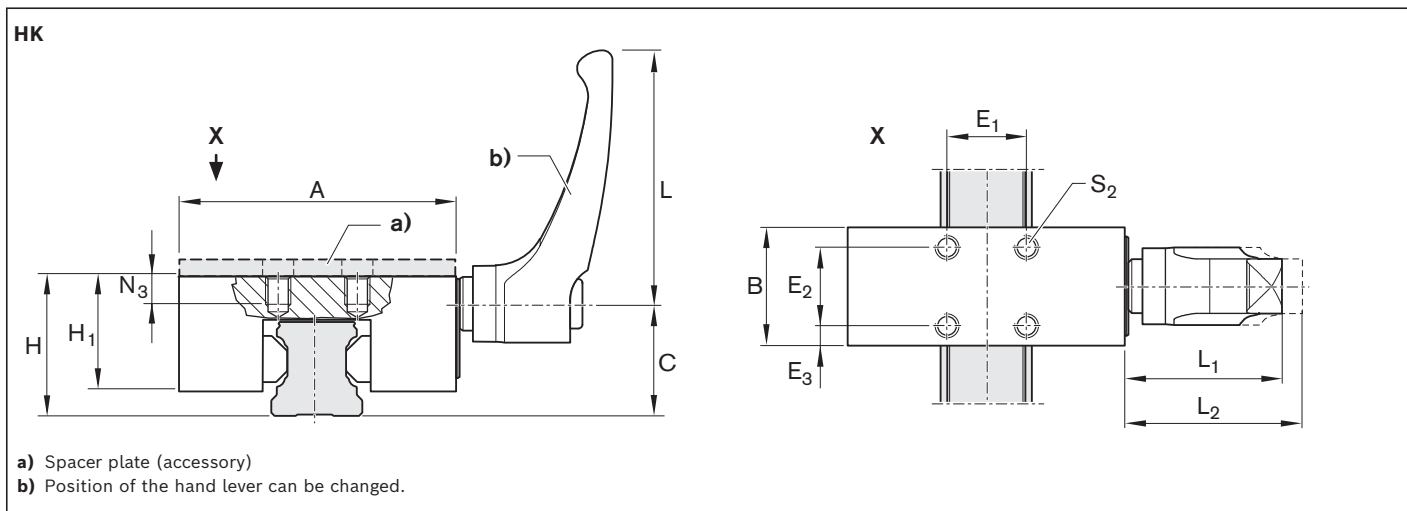

Size	Dimensions (mm)												Mass (kg)	
	A	B	C	E ₁	E ₂	E ₃	H	H ₁ ³⁾	L	L ₁	L ₂ ²⁾	N ₃		S ₂
15	47	25	19.0	17	17	4.0	24	19	44	30.0	33.0	5	M4	0.16
20	60	24	24.5	15	15	4.5	30	23	44	30.0	33.0	6	M5	0.23
25	70	30	29.3	20	20	5.0	36	29	64	38.5	41.5	7	M6	0.43
30	90	39	34.0	22	22	8.5	42	33	78	46.5	50.5	8	M6	0.82
35	100	39	38.0	24	24	7.5	48	41	78	46.5	50.5	10	M8	1.08
45	120	44	47.0	26	26	9.0	60	48	78	46.5	50.5	14	M10	1.64
55	140	49	56.5	30	30	9.5	70	51	95	56.5	61.5	14	M14	1.71
65	160	64	69.5	35	35	14.5	90	66	95	56.5	61.5	20	M16	2.84

- 1) The inspection is done in a mounted state with a lubricated layer (ISO-VG 68).
- 2) Hand lever disengaged
- 3) For ball runner block .H. (...high...) Spacer plate necessary

Manual clamping units HK

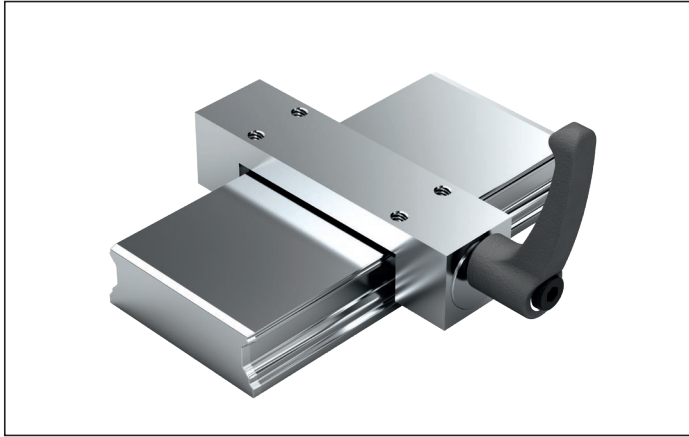

R1619 .42 83

Note

Can be used on all ball guide rails BNS.

Manual clamping unit

- ▶ Operating temperature range t: 0 – 70°C

Instruction for mounting

- ▶ Make sure the connection structure is rigid.
- ▶ Observe the mounting instructions prior to commissioning.

⚠ Observe the safety instructions on clamping and braking units.

Size	Material number	Holding force ¹⁾ (N)	Tightening torque (Nm)
25/70	R1619 242 83	1200	7
35/90	R1619 342 83	2000	15

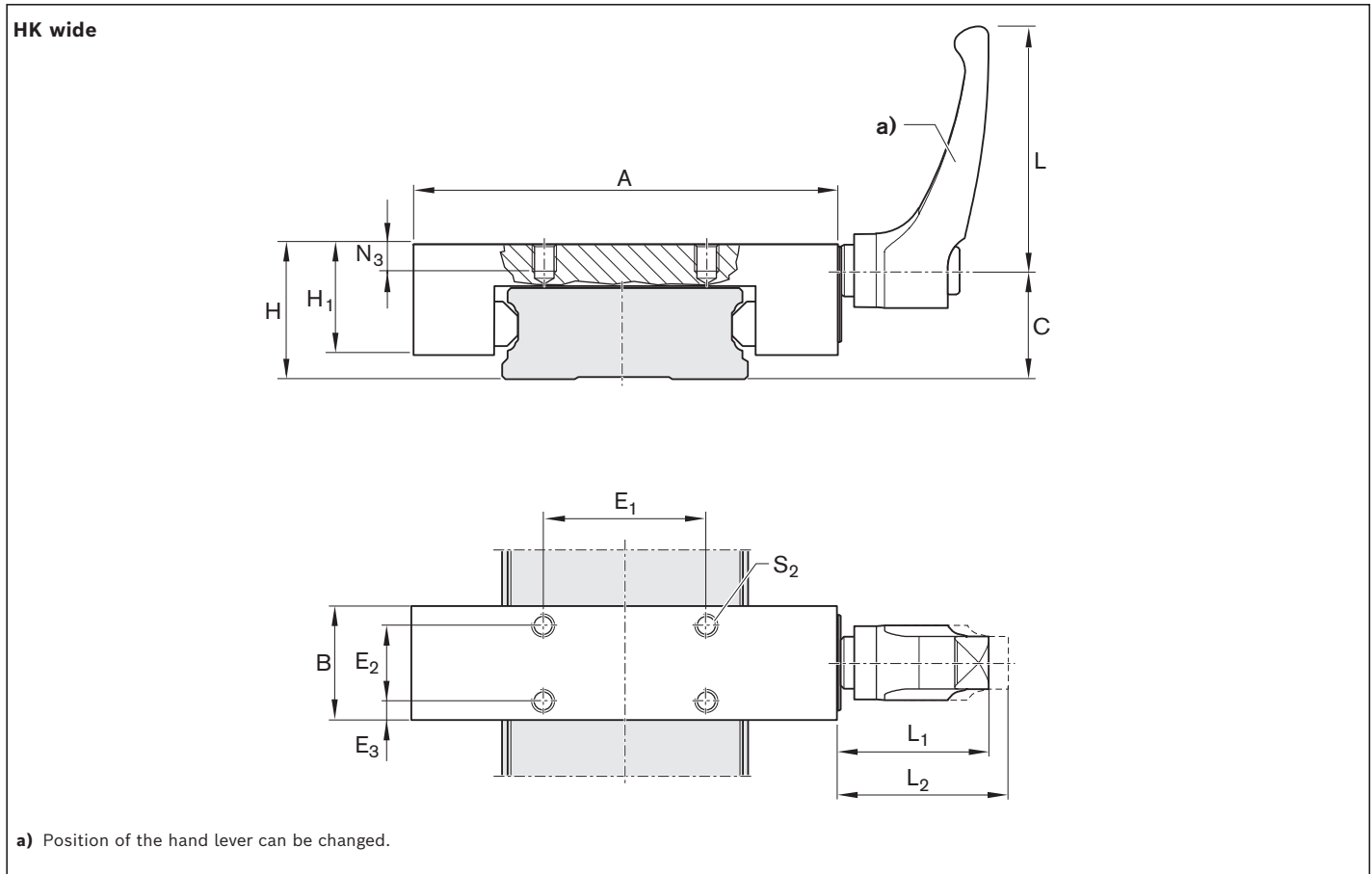

Size	Dimensions (mm)												Mass (kg)	
	A	B	C	E ₁	E ₂	E ₃	H	H ₁	L	L ₁	L ₂ ²⁾	N ₃		S ₂
25/70	120	39	28.2	50	25	7.0	35	30	64	38.5	41.5	11	M6	0.77
35/90	145	39	38.0	60	20	9.5	50	39	78	46.5	50.5	11	M8	1.38

1) The inspection is done in a mounted state with a lubricated layer (ISO-VG 68).

2) Hand lever disengaged

Spacer plate

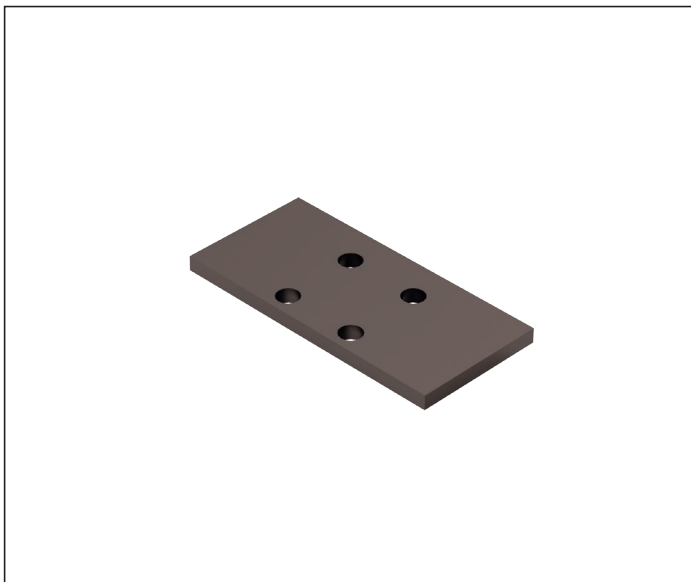

for clamping units **MK, MKS and HK**

Note

Suitable for mounting with high ball runner block SNH R1621 and SLH R1624.

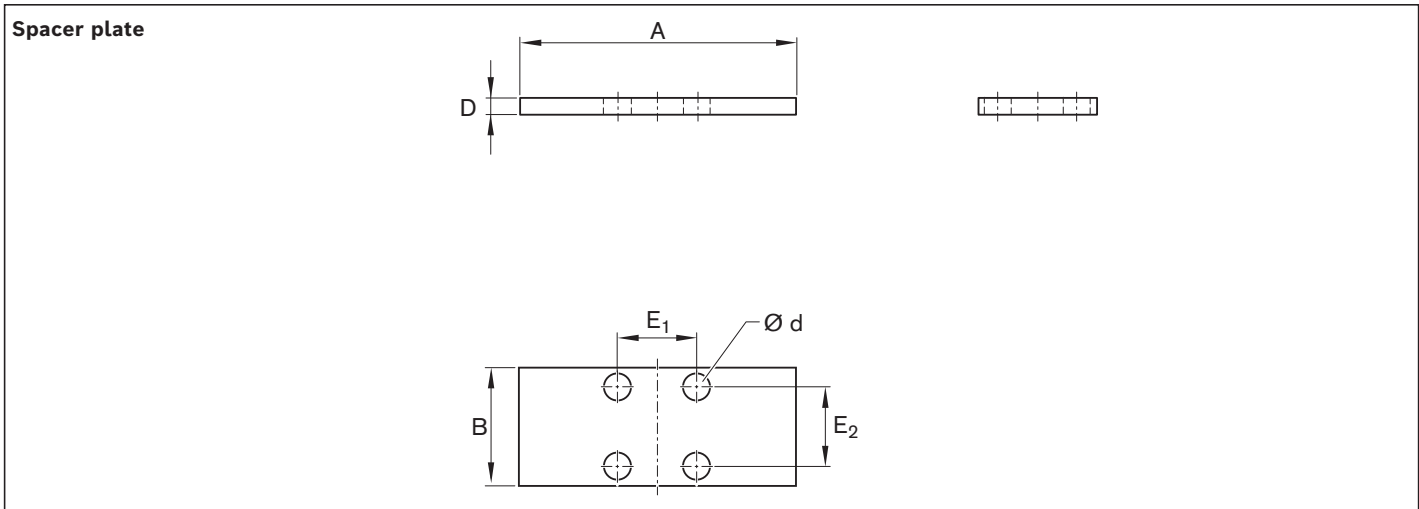

R1619 .40 65

Suitable for clamping units:

- ▶ R1619 .42 60 (MK)
- ▶ R1619 .40 60 (MKS)

Size	Material number	Dimensions (mm)						Mass (kg)
		A	B	D	d	E ₁	E ₂	
15	R1619 140 65	55	39	4	4.5	15	15	0.065
25	R1619 240 65	75	35	4	6.5	20	20	0.078
30	R1619 740 65	90	39	3	8.5	22	22	0.077
35	R1619 340 65	100	39	7	8.5	24	24	0.202
45	R1619 440 65	120	49	10	10.5	26	26	0.434
55	R1619 540 65	128	49	10	10.5	30	30	0.465

R1619 .42 .5

Suitable for clamping units:

- ▶ R1619 .42 82 (HK)

Size	Material number	Dimensions (mm)						Mass (kg)
		A	B	D	d	E ₁	E ₂	
15	R1619 142 85	47	25	4	4.5	17	17	0.035
25	R1619 242 85	70	30	4	6.5	20	20	0.062
30	R1619 742 85	90	39	3	6.5	22	22	0.080
35	R1619 340 65	100	39	7	8.5	24	24	0.202
45	R1619 442 85	120	44	10	10.5	26	26	0.387
55	R1619 542 85	140	49	10	14.5	30	30	0.511

Safety instructions clamping and braking units

General safety instructions

- ⚠ During all work on the clamping units, the respective valid instructions by UVV, VDE, the safety notes and instruction for mounting are to be observed!
- ⚠ The clamping units do not have any guiding function. A runner block can therefore not be replaced with a clamping unit. The ideal position of the clamping unit lies between two runner blocks. When using several clamping units, these should be distributed evenly on both guide rails in order to attain maximum rigidity for the overall construction.
- ⚠ For hydraulic clamping and braking units, the return pressure in the tank line must be lower than 1.5 bar!
- ⚠ Consider the response times of the clamping and braking units!
- ⚠ The clamping unit is not intended for securing suspended loads!
- ⚠ Do not remove the cover of the safety clamping unit - spring under tension!
- ⚠ The transport lock may only be removed if:
 - The hydraulic port has been pressurized with the operating pressure according to instructions.
 - The air port has been pressurized with compressed air to at least 4.5 bar (MBPS) or 5.5 bar (UBPS, MKS) according to instructions.
- ⚠ The clamping unit may only be de-pressurized when the appropriate ball guide rail or transport lock is in position between the contact profiles!
- ⚠ The use of clamping and braking units is not permissible on ball guide rails with integrated measuring systems.

Additional notes for clamping and braking units

- ⚠ The clamping and braking units are suitable for usage in safety-critical applications for braking and clamping. The safe function of the total system in which the clamping and braking units are used is primarily defined by the controller for this system. The technical configuration of this system and the controller is to be undertaken by the manufacturer of the higher level system, assembly, plant or machine. During this process the safety-related requirements for functional safety are to be observed.

Additional notes for clamping units

- ⚠ The unit may not be used as a braking unit! For use only when the axis is at a standstill!
- ⚠ Pressure may only be applied when the unit is properly mounted on the ball guide rail!

General instructions for mounting

The following notes relating to mounting apply to all ball rail systems. However, different specifications exist with regard to the parallelism of the ball guide rails and to bolting the ball runner blocks with screws and locating pins. This information is provided separately alongside the descriptions of the individual types of ball rail systems.

- ⚠ In the case of overhead installation (hanging installation) or vertical installation, the ball runner block can release from the ball guide rail due to the balls being lost or broken. Secure the ball runner block from falling! Risk of death! We recommend protection against falling loads!
- ⚠ Rexroth ball rail systems are high-quality products. Use with extreme care during transport and mounting. The same care must be taken with cover strips. All steel parts are protected with anti-corrosion oil. It is not necessary to remove this oil, provided that the recommended lubricants are used.

Installation examples

Ball guide rails

Each ball guide rail has ground reference surfaces on both sides.

Possibilities for side fixing:

- 1 Reference edges
- 2 Clamping strips
- 3 V-guides

Note

- ▶ Ball guide rails without side fixing have to be aligned straight and parallel when mounting, preferably using a straightedge.
- ▶ For guideline values for permissible lateral force without additional lateral retention, see corresponding ball runner blocks and instructions for mounting, page 206.

Ball runner blocks

Each ball runner block has a ground reference edge on one side (see dimension V_1 in the dimension drawings).

Possibilities for additional fixing:

- 1 Reference edges
- 2 Clamping strips
- 4 Locating pins

Mounting with fixing of both ball guide rails and both ball runner blocks

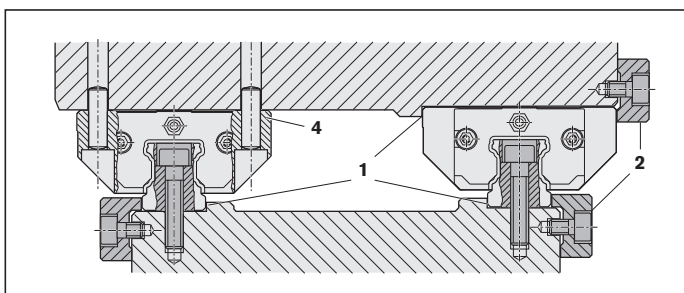

Mounting with fixing of one ball guide rail and one ball runner block

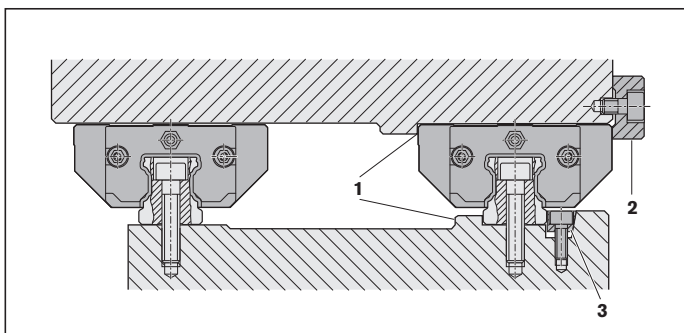

Notes

- ▶ Before installing the components, clean and degrease all mounting surfaces.
- ▶ Please ask for the "Mounting Instructions for ball rail systems".
- ▶ After mounting, it should be possible to move the ball runner block easily.

Fastener

Calculating screw connections

The screw connections in runner blocks and roller guide rails produce maximum traction forces $F_{0z \max}$, maximum static torsional moments $M_{0x \max}$ and maximum static side load $F_{0y \max}$ without stop strips that the linear guide can transfer. The maximum load on a profiled rail system is defined not only by the static load capacity C_0 in accordance with ISO 14728 Part 2 and the static load moments M_{t0} , but also by the screw connections.

As a rule, ball runner blocks are fastened using 4 or 6 screws. Ball guide rails have one or two rows of screw connections in regular distances, whereby the screws located directly under the runner block are subject to the most stress. If the runner block and rail are fastened with screws in the same strength class, the bolting between the rail and the mounting base (O3 or O6) is critical to the maximum forces and moments that can be transferred.

Calculation of the values in the table for strength class 8.8, 10.9 and 12.9 are based on DIN 637 (August 2013):

Ball bearings – safety regulations for dimensioning and operation of profiled rail systems with recirculating rolling elements. In comparison to the standard, the values determined by Bosch Rexroth include a higher safety factor. Screw connections are calculated based on the dimensions in the catalog (screw sizes, runner block lengths, clamping lengths, screw-in depths, bore diameters, rail separations of the rail bore holes, rail width, etc.).

Deviant screw connections are to be recalculated according to VDI 2230. The maximum static traction force and maximum static torsional moment of a ball guide rail system are the product of the sum of the axial forces on the rail screws within the flow of forces. However, for the maximum static side load, the sum of the clamping forces on the rail screws within the flow of forces is crucial.

Input values for calculation:

- | | |
|--|------------------|
| - Friction coefficient in the thread | $\mu_G = 0.125$ |
| - Friction coefficient at the head surface | $\mu_K = 0.125$ |
| - Friction coefficient in the joint | $\mu_T = 0.2$ |
| - Tightening torque for torque wrench | $\alpha_A = 1.5$ |

The applied friction coefficients and the tightening torque are common values in practice. Depending on the customer application and mounting procedure, the actual input parameters may deviate considerably from the assumptions. This must be checked after each sizing and screw connections must be recalculated with actual values according to VDI 2230 as necessary. Even slight deviations from the assumptions in the Bosch Rexroth calculations lead to variations in tightening torque and maximum transferable static tension forces, torsional moments and lateral forces.

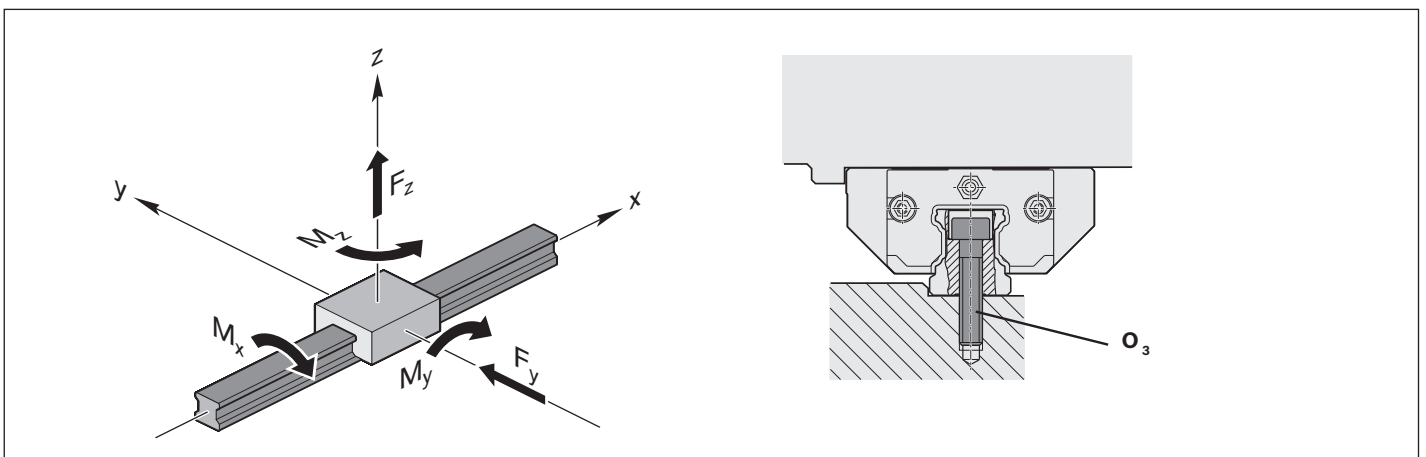

Fastener

Tightening torques for profiled rail systems

The tightening torques for screw strength classes 8.8, 10.9 and 12.9 were calculated for the dimensions of a Rexroth ball rail system. Detailed descriptions of the possible screw connections O1 to O6 can be found on the following pages.

Runner block

Size	FKS, FNS, FLS, FKN, FNN, BNS, CNS								SKS, SNS, SLS, SKN, SNN, SNH, SLH			
	for bolting from above				for bolting from below				for bolting from above			
	O4				O1&O2				O5			
		8.8	10.9	12.9		8.8	10.9	12.9		8.8	10.9	12.9
15	M5	6.3	9.2	11	M4	3.3	4.8	4.9	M4	3.1	4.6	5.4
20	M6	11	16	18	M5	6.5	9.5	11	M5	6.3	9.2	11
25	M8	26	38	44	M6	8.4	8.4	8.4	M6	11	16	18
30	M10	51	74	87	M8	27	28	28	M8	26	38	44
35	M10	51	74	87	M8	27	28	28	M8	26	38	44
45	M12	87	130	130	M10	52	66	66	M10	51	74	87
55	M14	140	200	220	M12	81	81	81	M12	87	130	130
65	M16	210	310	340	M14	140	150	150	M14	210	310	340

Guide rail

Size	for bolting from above				for bolting from below			
	O3				O6			
		8.8	10.9	12.9		8.8	10.9	12.9
15	M4	3.1	4.6	5.4	M5	6.3	9.2	11
20	M5	6.4	9.4	11	M6	11	16	18
25	M6	11	16	18	M6	11	16	18
30	M8	26	38	44	M8	26	38	44
35	M8	26	38	44	M8	26	38	44
45	M12	88	110	110	M12	87	130	140
55	M14	140	190	190	M14	140	200	230
65	M16	220	300	300	M16	210	310	360

Maximum static traction forces and torsional moments on profiled rail systems

The screw connections in a profiled rail system can only transfer a limited traction force F_z or a limited torsional moment M_x . If these limit values are exceeded, the guideway will lift off of the adjacent structure. The permissible values for a guideway are the product of the maximum possible axial force on a screw connection in the guide rail. Exceeding the indicated maximum static load is not permissible.



The table values are guideline values for the permissible static traction force $F_{0z \max}$ and torsional moments $M_{0x \max}$ that are only applicable when the following conditions are met:

- Screw sizes, screw quantity and connecting dimensions as listed in the catalog
- Same fastening screw strength class for runner blocks and rails
- Steel adjacent structure
- Traction force F_z or torsional moment M_x are static
- Traction force F_z and torsional moment M_x do not occur simultaneously
- No interaction with side load F_y or longitudinal moment M_y/M_z

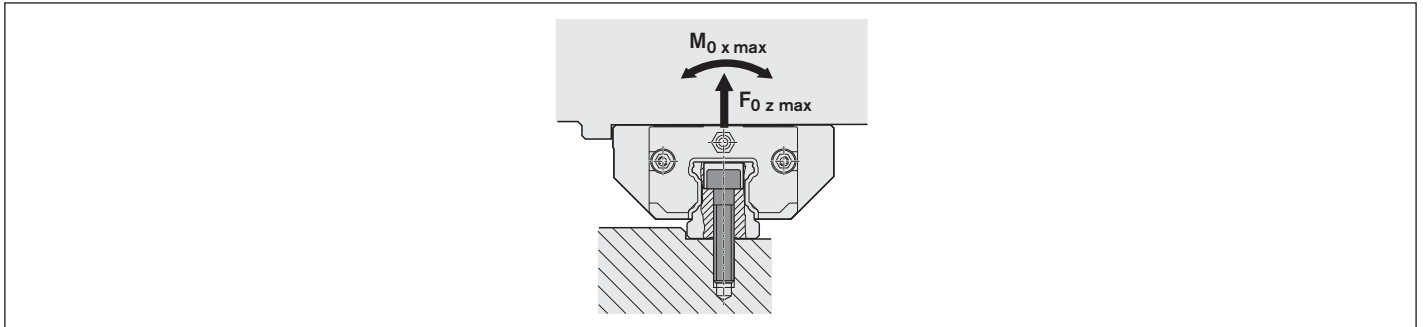

If these conditions are not met, recalculate the screw connection in accordance with VDI 2230. If the applied loads are just below the limit values, Bosch Rexroth also recommends checking the screw connections.



Tensile forces

Size	Maximum static tensile forces $F_{0z\ max}$ in [N]								
	 Short			 Normal length			 Long		
	xKx			xNx			xLx		
	8.8	10.9	12.9	8.8	10.9	12.9	8.8	10.9	12.9
15	2410	3900	4700	2410	3900	4700	2410	3900	4700
20	4220	6690	8010	4220	6690	8010	4600	7300	8730
25	5520	8740	10500	5520	8740	10500	7340	11600	13900
30	10100	16000	19200	10100	16000	19200	11300	17900	21500
35	10500	16400	19600	10500	16400	19600	13900	21700	25900
45	25400	34900	34900	25400	34900	34900	32300	44300	44300
55	36500	53700	53700	36500	53700	53700	47400	69800	69800
65	50600	76400	77500	50600	76400	77500	65800	99400	101000

Torsional moments

Size	Maximum static torsional moments $M_{0x\ max}$ in [Nm]								
	 Short			 Normal length			 Long		
	xKx			xNx			xLx		
	8.8	10.9	12.9	8.8	10.9	12.9	8.8	10.9	12.9
15	16	26	31	16	26	31	16	26	31
20	38	60	72	38	60	72	41	66	79
25	58	92	110	58	92	110	77	120	150
30	130	210	250	130	210	250	150	230	280
35	170	260	310	170	260	310	220	350	410
45	550	750	750	550	750	750	690	950	950
55	910	1340	1340	910	1340	1340	1190	1740	1740
65	1490	2250	2290	1490	2250	2290	1940	2930	2970

Fastener

Maximum static side load without stop strips

For a secure structure, Rexroth recommends using stop strips on the runner block and guide rail. If stop strips are not used on the runner block or the rail, then if a load is applied in the transverse direction the guideway may slip. The clamping force of the screw connection is too low as soon as the side loads in the table are exceeded.



The table values are guideline values for the permissible static side loads $F_{0y\ max}$ that are only applicable when the following conditions are met:

- Screw sizes, screw quantity and connecting dimensions as listed in the catalog
- Same fastening screw strength class for runner blocks and rails
- Steel adjacent structure
- No interaction with traction force F_z , torsional moments M_x or longitudinal moments M_y/M_z

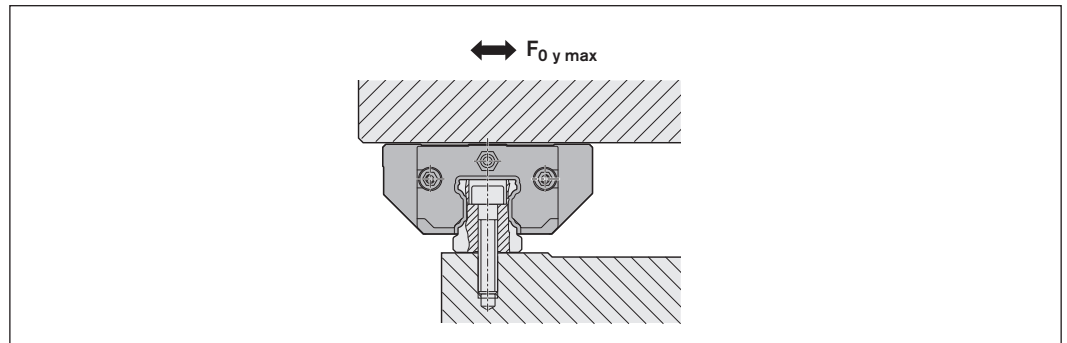
If these conditions are not met, recalculate the screw connection in accordance with VDI 2230. If the applied loads are just below the limit values, Bosch Rexroth also recommends checking the screw connections.



Lateral forces

Size	Maximum static lateral forces $F_{0y\ max}$ in [N]								
	 Short			 Normal length			 Long		
	xKx			xNx			xLx		
	8.8	10.9	12.9	8.8	10.9	12.9	8.8	10.9	12.9
15	370	600	720	370	600	720	370	600	720
20	640	1010	1210	640	1010	1210	690	1100	1320
25	900	1430	1710	900	1430	1710	1200	1900	2270
30	1630	2600	3110	1630	2600	3110	1830	2910	3480
35	1710	2670	3190	1710	2670	3190	2260	3530	4210
45	4110	5330	5330	4110	5330	5330	5220	6770	6770
55	5920	8220	8220	5920	8220	8220	7700	10700	10700
65	8210	11800	11800	8210	11800	11800	10700	15300	15300

**Reference edges,
corner radii**

Combination examples

The combinations shown here are examples. Basically, any ball runner block may be combined with any of the ball guide rail types offered.

Fastening screws

⚠ Always make sure the screws are secure where there are high screw loads!

For more information on this topic, see section "General instructions for mounting".

Ball guide rail with normal and long ball runner blocks

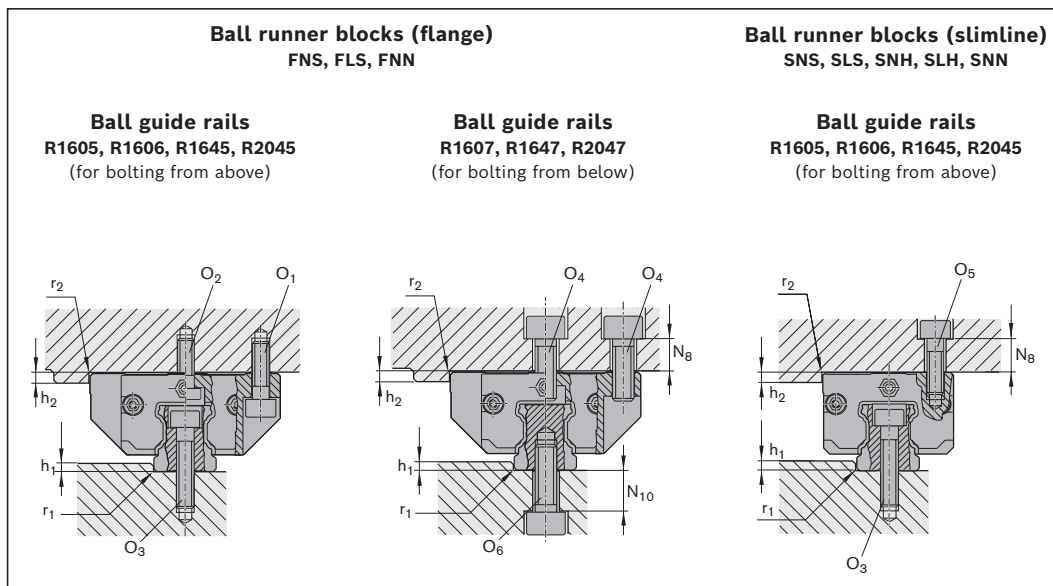

Size	Dimensions (mm)						
	$h_{1 \min}$	$h_{1 \max}^{1)}$	h_2	N_8	N_{10}	$r_{1 \max}$	$r_{2 \max}$
15	2.5	3.5	4	6	7.0	0.4	0.6
20	2.5	4.0	5	9 10 ³⁾	9.5 -	0.6	0.6
25	3.0	5.0	5	10 11 ³⁾	12.0 -	0.8	0.8
30	3.0	5.0	6	10	9.0	0.8	0.8
35	3.5	6.0	6	13	13	0.8	0.8
45	4.5	8.0	8	14	13	0.8	0.8
55	7.0	10.0	10	20	23	1.2	1.0
65	7.0	10.0	14	22	26	1.2	1.0

1) When using clamping and braking units, please take account of the values H1.

Size	Screw sizes					
	Ball runner block				Ball guide rail	
	O_1 ISO 4762 4 pieces	$O_2^{2)}$ DIN 6912 2 pieces	$O_4^{1) 2)}$ ISO 4762 6 pieces	O_5 ISO 4762 4 pieces	O_3 ISO 4762	O_6 ISO 4762
15	M4x12	M4x10	M5x12	M4x12	M4x20	M5x12
20	M5x16	M5x12	M6x16	M5x16	M5x25	M6x16
25	M6x20	M6x16	M8x20	M6x18	M6x30	M6x20
30	M8x25	M8x16	M10x20	M8x20	M8x30	M8x20
35	M8x25	M8x20	M10x25	M8x25	M8x35	M8x25
45	M10x30	M10x25	M12x30	M10x30	M12x45	M12x30
55	M12x40	M12x30	M14x40	M12x35	M14x50	M14x40
65	M14x45	M14x35	M16x45	M16x40	M16x60	M16x45

- 1) For fixing the ball runner block from above with only 4 O_4 screws:
Permissible side load 1/3 lower, and lower rigidity
- 2) When fastening the ball runner block with 6 screws:
Tighten centerline screws to tightening torque M_A of strength class 8.8
- 3) Ball runner block SNN

Fastener

Locating pins

⚠ If the guideline values for the permissible lateral force are exceeded (see the corresponding ball runner blocks), you must fix the ball runner block additionally by pinning.

For the recommended dimensions for pin holes, refer to the dimension drawing and the dimensions.

Possible pin types

- ▶ Tapered pin (hardened) or
- ▶ Straight pin DIN ISO 8734

Note

- ▶ At the recommended positions for pin holes, there may be pre-drilled holes in the middle of the ball runner block due to production-related issues ($\varnothing < S_{10}$). They are suitable for drilling out.
- ▶ If it is necessary to carry out pinning at a different position (e.g. the middle lube connection), dimension E_2 must not be exceeded in the longitudinal direction (for dimension E_2 , refer to the dimension tables of the corresponding ball runner blocks). Comply with dimensions E_1 and E_4 !
- ▶ Do not finish the pin holes until after installation.
- ▶ Please request the "Mounting instructions for ball rail systems."

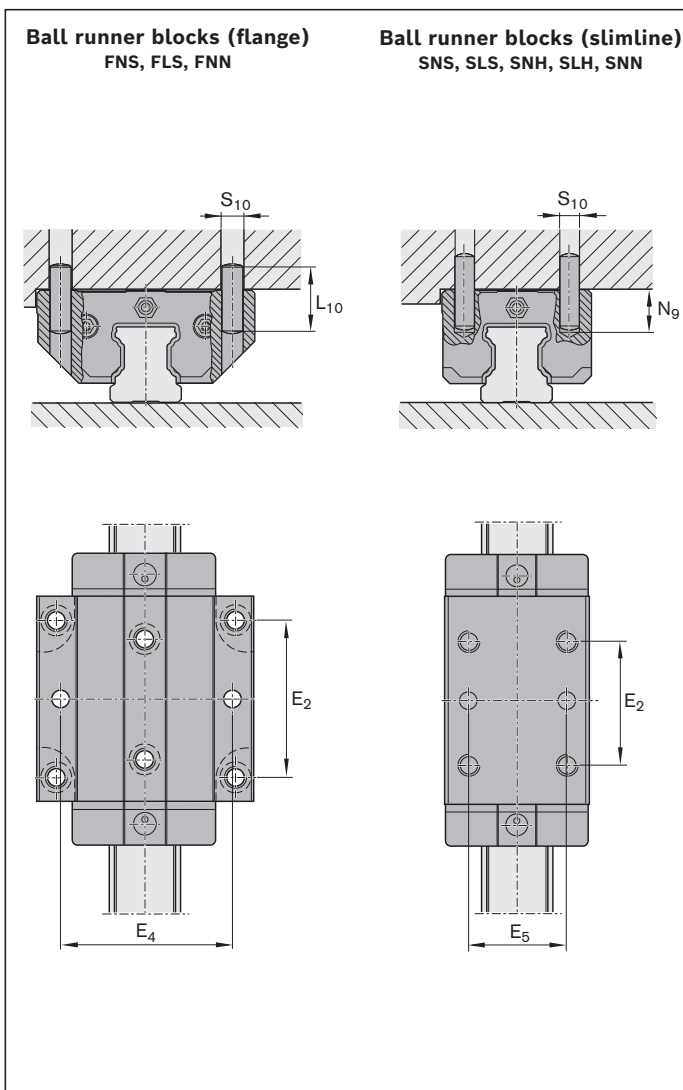

Size	Dimensions (mm)				
	E_4	E_5	$L_{10}^{1)}$	$N_{9 \max}$	$S_{10}^{1)}$
15	38	26	18	6.0	4
20	53 49 ²⁾	32	24	7.5 6.5 ²⁾	5
25	55 60 ²⁾	35	32	9.0 7.0 ²⁾	6
30	70	40	36	12.0	8
35	80	50	40	13.0	8
45	98	60	50	18.0	10
55	114	75	60	19.0	12
65	140	76	60	22.0	14

1) Tapered pin (hardened) or straight pin (DIN ISO 8734)
 2) Ball runner blocks FNN and SNN

Reference edges, corner radii

Combination examples

The combinations shown here are examples. Basically, any ball runner block may be combined with any of the ball guide rail types offered.

The bolting of the ball runner blocks with 2 screws is completely sufficient up to the maximum load. (For maximum load capacity and load moments, see corresponding ball runner blocks).

Fastening screws

⚠ Always make sure the screws are secure where there are high screw loads!

For more information on this topic, see section "General instructions for mounting".

Ball guide rail with ball runner block, short and super.

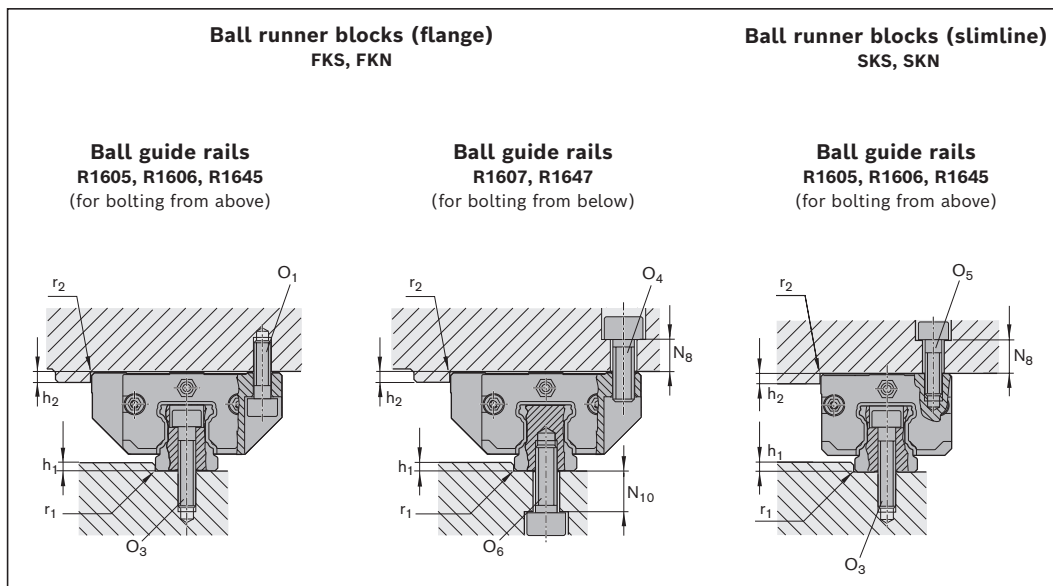

Size	Dimensions (mm)						
	$h_{1 \min}$	$h_{1 \max}^{1)}$	h_2	N_8	N_{10}	$r_{1 \max}$	$r_{2 \max}$
15	2.5	3.5	4	6	7.0	0.4	0.6
20	2.5	4.0	5	9	9.5	0.6	0.6
25	3.0	5.0	5	10 ²⁾	–	0.8	0.8
				11 ²⁾	–		
30	3.0	5.0	6	10	9.0	0.8	0.8
35	3.5	6.0	6	13	13.0	0.8	0.8

- 1) When using clamping and braking units, please take account of the values H1.
- 2) Ball runner block SKN

Size	Screw sizes				
	Ball runner block			Ball guide rail	
	O_1 ISO 4762 2 pieces	O_4 ISO 4762 2 pieces	O_5 ISO 4762 2 pieces	O_3 ISO 4762	O_6 ISO 4762
15	M4x12	M5x12	M4x12	M4x20	M5x12
20	M5x16	M6x16	M5x16	M5x25	M6x16
25	M6x20	M8x20	M6x18	M6x30	M6x20
30	M8x25	M10x20	M8x20	M8x30	M8x20
35	M8x25	M10x25	M8x25	M8x35	M8x25

Fastener

Locating pins

⚠ If the guideline values for the permissible lateral force are exceeded (see the corresponding ball runner blocks), you must fix the ball runner block additionally by pinning.

For the recommended dimensions for pin holes, refer to the dimension drawing and the dimensions.

Possible pin types

- ▶ Tapered pin (hardened) or
- ▶ Straight pin DIN ISO 8734

Note

- ▶ At the recommended positions for pin holes, there may be pre-drilled holes in the middle of the ball runner block due to production-related issues ($\varnothing < S_{10}$). They are suitable for drilling out. Comply with dimensions E_4 and E_5 !
- ▶ Do not complete the pin holes until after mounting. Please request the "Mounting instructions for ball rail systems."

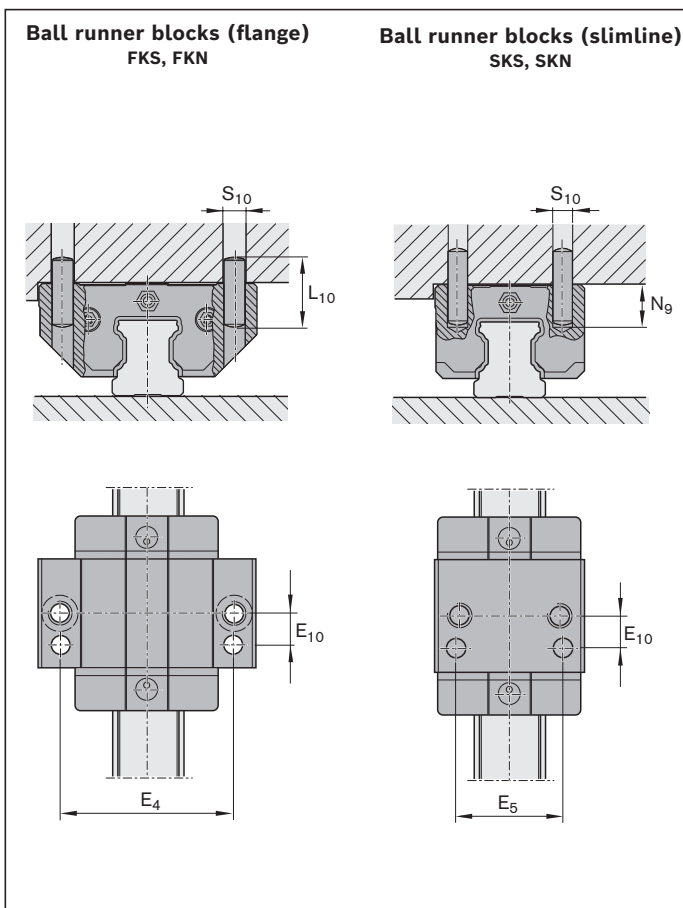

Size	Dimensions (mm)					
	E_4	E_5	E_{10}	$L_{10}^{1)}$	$N_{9 \max}$	$S_{10}^{1)}$
15	38	26	9	18	3.0	4
20	53	32	10	24	3.5	5
	49 ²⁾				2.0 ²⁾	
25	55	35	11	32	7.0	6
	60 ²⁾				5.0 ²⁾	
30	70	40	14	36	10.0	8
35	80	50	15	40	12.0	8

- 1) Tapered pin (hardened) or straight pin (DIN ISO 8734)
- 2) Ball runner blocks FKN and SKN

Permissible misalignments for super ball runner blocks

On the ball guide rail and on the ball runner block

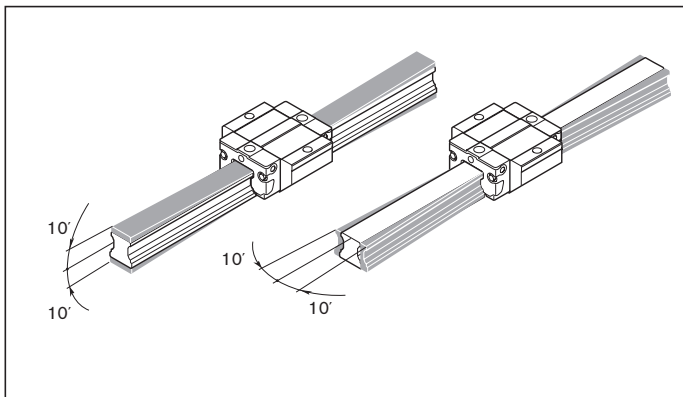

Ball guide rail with ball runner block, wide

**Reference edges,
corner radii, screw sizes**

Combination examples

The combinations shown here are examples. Basically, any ball runner block may be combined with any of the ball guide rail types offered.

Fastening screws

⚠ Always make sure the screws are secure where there are high screw loads!

For more information on this topic, see section "General instructions for mounting".

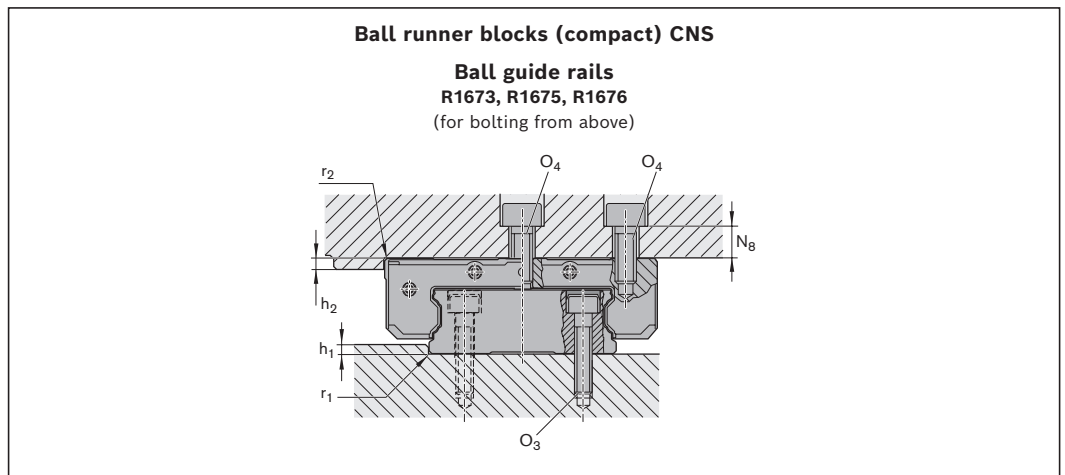
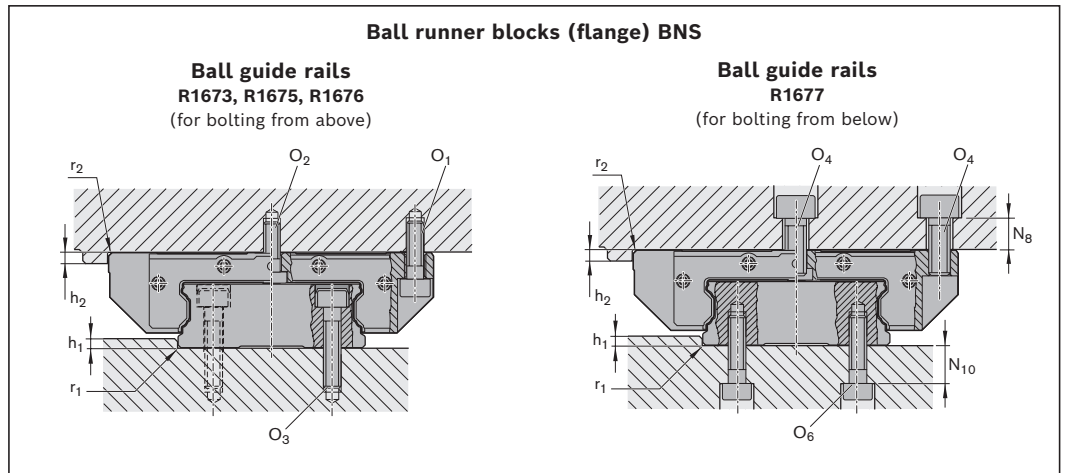

Size	Dimensions (mm)							
	$h_{1 \min}$	$h_{1 \max}^{1)}$	h_2	N_8	$N_8^{2)}$	N_{10}	$r_{1 \max}$	$r_{2 \max}$
20/40	2.0	2.5	4	9.5	11	5.5	0.5	0.5
25/70	3.0	4.5	5	10.0	13	9.0	0.8	0.8
35/90	3.5	6.0	6	13.0	–	11.0	0.8	0.8

Size	Screw sizes					
	Ball runner block			Ball guide rail		
	O_1 ISO 4762 4 pieces	$O_2^{3)}$ DIN 6912 2 pieces	$O_4^{3)}$ ISO 4762 6 pieces	O_3 ISO 4762	O_6 ISO 4762	
20/40	M5x16	–	M6x16	M4x20	M5x12	
25/70	M6x20	M6x16	M8x20	M6x30	M6x20	
35/90	M8x25	M8x20	M10x25	M8x35	M8x25	

- 1) When using clamping and braking units, please take account of the values H1.
- 2) Ball runner blocks CNS
- 3) When fastening the ball runner block with 6 screws:
Tighten centerline screws to tightening torque M_A of strength class 8.8.
As a matter of principle, centerline fastening screws should be used as well, otherwise there is a risk of a decreasing preload.

Fastener

Locating pins

⚠ If the guideline values for the permissible lateral force are exceeded (see the corresponding ball runner blocks), you must fix the ball runner block additionally by pinning.

For the recommended dimensions for pin holes, refer to the dimension drawing and the dimensions.

Possible pin types

- ▶ Tapered pin (hardened) or
- ▶ Straight pin DIN ISO 8734

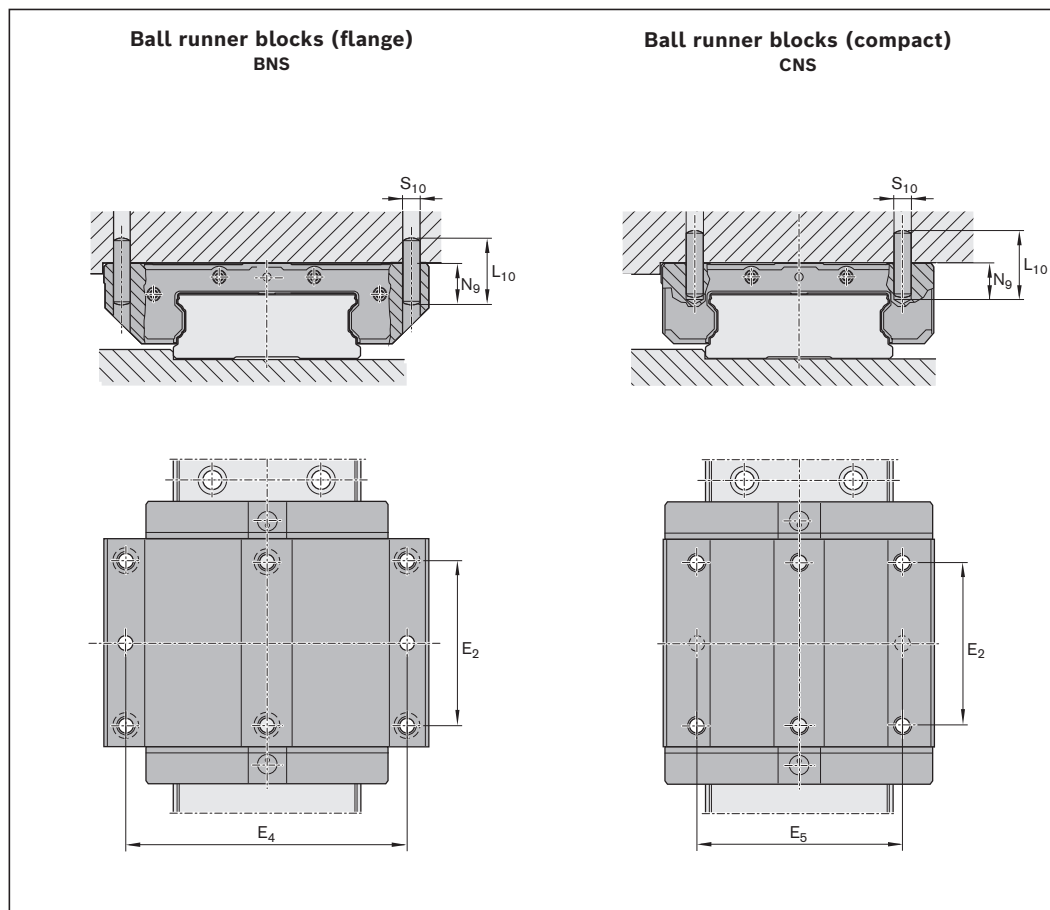

Size	Dimensions (mm)				
	E_4	E_5	$L_{10}^{1)}$	$N_{9 \max}$	$S_{10}^{1)}$
20/40	70	46	24	7	5
25/70	107	76	32	8	6
35/90	144	-	32	8	8

1) Tapered pin (hardened) or straight pin (DIN ISO 8734)

Note

- ▶ At the recommended positions for pin holes, there may be pre-drilled holes in the middle of the ball runner block due to production-related issues ($\varnothing < S_{10}$). They are suitable for drilling out.
- ▶ If it is necessary to carry out pinning at a different position (e.g. the middle lube connection), dimension E_2 must not be exceeded in the longitudinal direction (for dimension E_2 , refer to the dimension tables of the corresponding ball runner blocks). Comply with dimensions E_4 and E_5 !
- ▶ Do not complete the pin holes until after mounting.
- ▶ Please request the "Mounting instructions for ball rail systems."

Installation tolerances

Vertical offset

If you comply with the permissible vertical offset S_1 and S_2 , the effect on the service life is, in general, negligible.

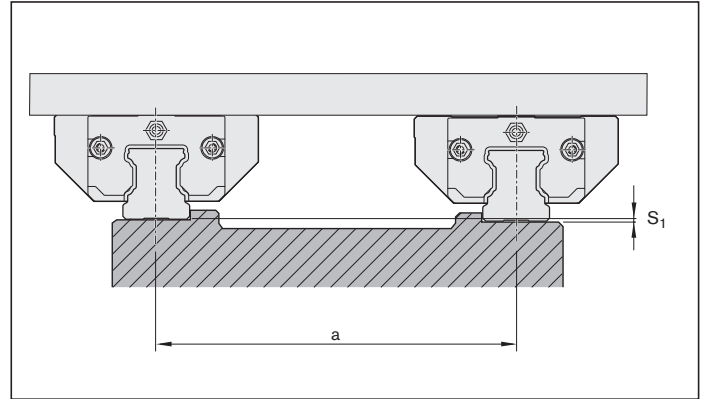

Permissible vertical offset in transverse direction S_1

The tolerance for dimension H is to be deducted from the permissible vertical offset S_1 of the ball guide rails according to the table containing the accuracy classes in the "General product description" chapter.

If $S_1 < 0$ applies, in the event of a combination of accuracy classes, select other tolerances in the "General product description" chapter.

Ball runner block	Calculation factor Y for preload class			
	C0	C1	C2	C3
Made of steel	$4.3 \cdot 10^{-4}$	$2.8 \cdot 10^{-4}$	$1.7 \cdot 10^{-4}$	$1.2 \cdot 10^{-4}$
Short made of steel	$5.2 \cdot 10^{-4}$	$3.4 \cdot 10^{-4}$	-	-
Super ball runner blocks	$8.0 \cdot 10^{-4}$	$6.0 \cdot 10^{-4}$	-	-
Made of aluminum	$7.0 \cdot 10^{-4}$	$5.0 \cdot 10^{-4}$	-	-

$$S_1 = a \cdot Y$$

Key

- S_1 = Permissible vertical offset of the ball guide rails (mm)
- a = Centerline-to-centerline distance between the ball guide rails (mm)
- Y = Calculation factor transverse direction (-)

Preload classes

- C0 = Without preload (clearance)
- C1 = Moderate preload
- C2 = Average preload
- C3 = High preload

Installation tolerances

Permissible vertical offset in longitudinal direction S_2

You must deduct from the permissible vertical offset S_2 of the ball runner blocks the "Max. difference of dimension ΔH on one rail" tolerance according to the table containing the accuracy classes in the "General product description" chapter.

If $S_2 < 0$ applies, in the event of a combination of accuracy classes select other tolerances in the "General product description" chapter.

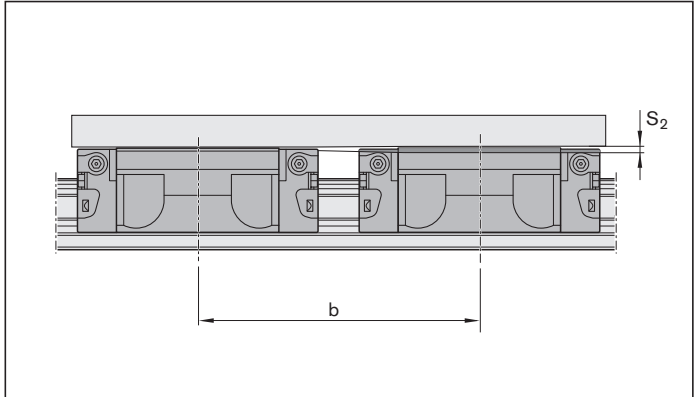

Ball runner block	Calculation factor X for ball runner block length		
	Short	Normal	Long
Made of steel	$6.0 \cdot 10^{-5}$	$4.3 \cdot 10^{-5}$	$3.0 \cdot 10^{-5}$
Made of aluminum	-	$6.0 \cdot 10^{-5}$	-

$$S_2 = b \cdot X$$

Key

- S_2 = Permissible vertical offset of the ball runner blocks (mm)
- b = Centerline-to-centerline distance between the ball runner blocks (mm)
- X = Calculation factor longitudinal direction (-)

Permissible nonlinearity in longitudinal direction for two consecutive super ball runner blocks

The ball runner blocks can automatically compensate for nonlinearities of 10' in the longitudinal direction.

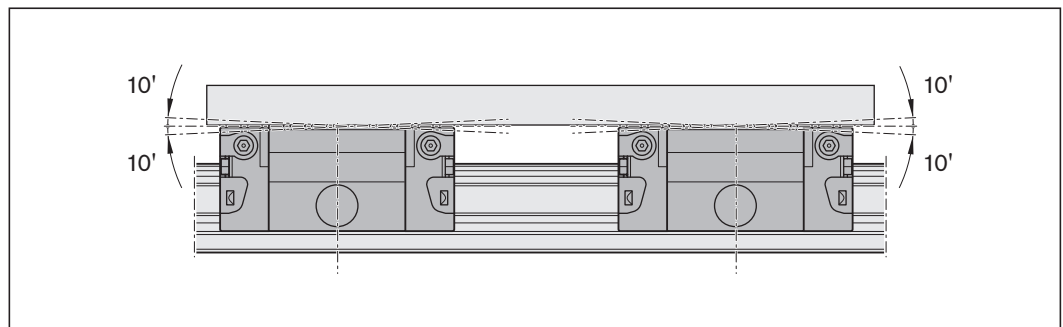

General notes

The following notes on mounting apply to all ball rail systems.

Rexroth ball rail systems are high-quality products.

Use with extreme care during transport and mounting. The same care must be taken with cover strips.

All steel parts are protected with anti-corrosion oil.

It is not necessary to remove this oil, provided that the recommended lubricants are used.

⚠ In the case of overhead installation (hanging installation), the ball runner block can release from the guide rail due to the balls being lost or broken. Secure the ball runner block from falling!

Parallelism offset of the mounted rails

Values measured on the ball guide rails and the ball runner blocks

The values for the parallelism offset P_1 apply to the entire standard range of ball runner blocks.

The parallelism offset P_1 causes a slight rise in the preload.

As long as the values specified in the table are met, the effect on the service life can generally be neglected.

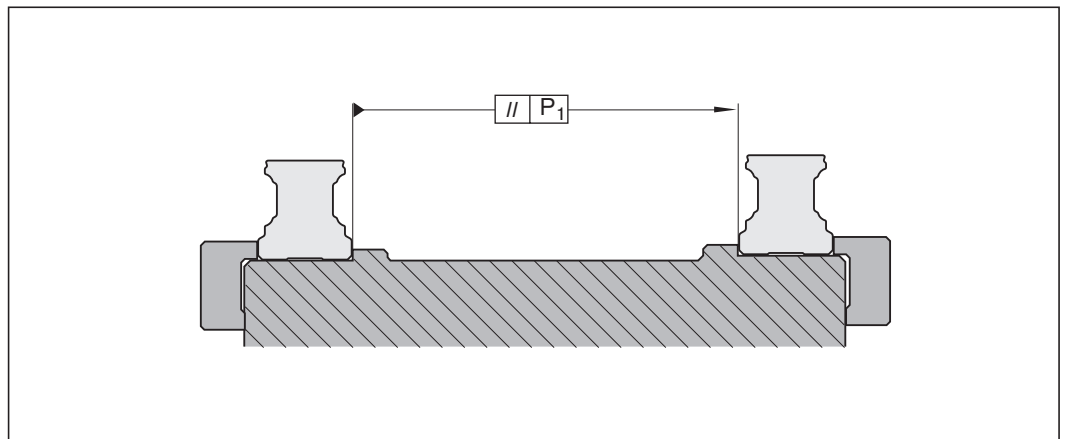

Ball runner blocks	Size	Parallelism offset P_1 (mm) for preload class			
		C0	C1	C2	C3
Ball runner blocks made of steel with precision installation ¹⁾	15	0.015	0.009	0.005	0.004
	20	0.018	0.011	0.006	0.004
	25	0.019	0.012	0.007	0.005
	30	0.021	0.014	0.009	0.006
	35	0.023	0.015	0.010	0.007
	45	0.028	0.019	0.012	0.009
	55	0.035	0.025	0.016	0.011
Ball runner blocks, short, made of steel	15	0.018	0.011	-	-
	20	0.022	0.013	-	-
	25	0.023	0.014	-	-
	30	0.025	0.017	-	-
	35	0.028	0.018	-	-
Super ball runner blocks	15	0.025	0.017	-	-
	20	0.029	0.021	-	-
	25	0.032	0.023	-	-
	30	0.035	0.026	-	-
	35	0.040	0.030	-	-
Aluminum ball runner blocks	15	0.021	0.014	-	-
	25	0.026	0.017	-	-
	30	0.029	0.019	-	-
	35	0.035	0.022	-	-

Preload classes

C0 = Without preload (clearance)

C1 = Moderate preload

C2 = Average preload

C3 = High preload

1) The precision installation unit is a rigid, high-precision surrounding structure. With standard installation, the surrounding structure is of flexible design and it is possible to work with **double** the tolerance values of the parallelism offset.

Composite ball guide rails

Notes on ball guide rails

- ▶ Matching partial sections of a composite ball guide rail are identified as such by a label on the packaging. All partial sections of the same rail have the same serial rail number.
- ▶ The numbering is marked on the top of the ball guide rail.

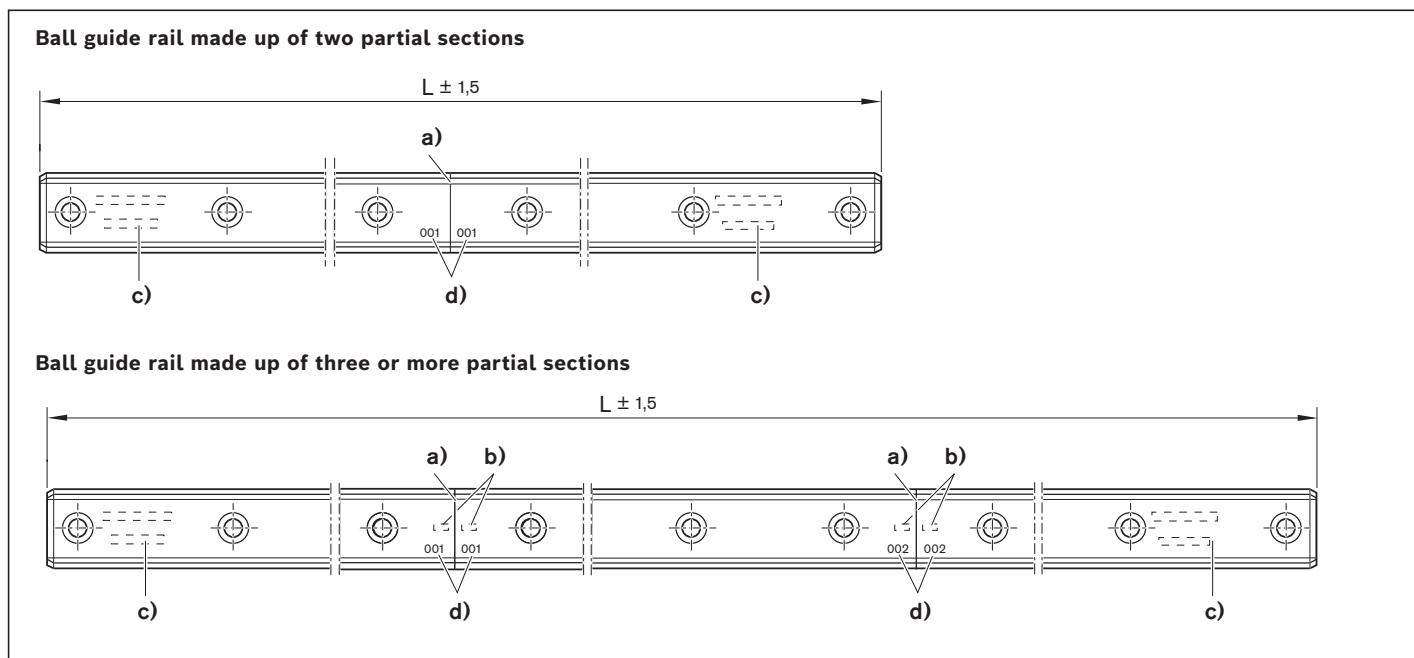

L = Rail length (mm)
 n_B = Number of holes (-)

- a) Joint
- b) Rail number
- c) Full rail identification on first and last sections
- d) Joint identification number

Note on cover strip

- ▶ For composite ball guide rails, a one-piece cover strip to cover the overall length L is supplied separately.
- ▶ Secure the cover strip!

Note on adjacent structures

Permissible mounting hole tolerances for adjacent structures

Size	Hole position tolerance (mm)
15 - 35	∅ 0.2
45 - 65	∅ 0.3

For composite ball guide rails, the actual tolerances of the individual sections may sum up. In such case, the fastening bore holes in the connecting structure may lie outside of the tolerances and a rework of the connecting structure may be required.

Notes on lubrication

- ▶ All specifications on lubrication are based on experimental values and field experience are recommendations by Bosch Rexroth.
- ▶ The service life of the ball rail system crucially depends on the lubrication. For this purpose, the documentation, especially the chapter on lubrication, must be read and understood completely.
- ▶ The operator is responsible for the selection and supply of the ball rail system with sufficient and suitable lubricant. These notes do not exempt the operator from the individual examination of the conformity and suitability of the lubricant for its application.
- ▶ For recommended lubricants, see chapter "Notes on Dynalub".

⚠ To safeguard the supply of lubricant, the lube fittings from the chapter "Accessories" must be used. When using other lube fittings it must be ensured that they are identical to Rexroth lube fittings.

⚠ If using a progressive lubrication system, with grease lubrication, please pay attention to the minimum dosing amount for relubrication stated in table 9.

⚠ We recommend carrying out initial lubrication separately using a grease gun before connecting to the central lubrication system.

If using a central lubrication system, you must make sure that all the pipes and elements are filled with lubricant and do not contain any air pockets until they are connected to the consumer (ball runner block).

The number of pulses results from the partial amounts and the piston distributor size.

▶ **With fluid grease lubrication according to table 9**

▶ **With oil lubrication according to table 14**

⚠ **The seals on the ball runner block must be oiled or lubricated with the respective lubricant before mounting.**

⚠ If using different lubricants than the ones specified, relubrication intervals may be shorter and performance may decrease with short stroke and load ratio; in addition, chemical interactions can take place between the plastics, lubricants and preservative agents. Single-line central lubrication systems also need to be able to pump these lubricants.

⚠ Lubricant reservoirs should contain an agitator to ensure the lubricant can flow (avoids hardening in the reservoir).

⚠ Do not use lubricants with solid particles (e.g. graphite or MoS₂).

⚠ With basic lubrication at the factory, both grease and oil lubrication is possible. In the case of relubrication, it is not possible to change from grease to oil lubrication, as the lubrication channels are already filled with grease and are therefore impermeable to oil.

⚠ Ball runner blocks without factory basic lubrication must be lubricated before commissioning.

⚠ When applying metalworking fluids at the start or after a relatively long standstill, carry out 2 to 5 lubrication pulses in succession. When the system is in operation, 3 to 4 pulses per hour are recommended, irrespective of the distance traveled. If possible, carry out lubrication in one lubricating stroke. Carry out cleaning cycles (see "Maintenance").

⚠ An unfavorable selection of coolant/lubricant may lead to damage to the ball rail system. We recommend getting in touch with the manufacturer of the coolant/lubricant. Bosch Rexroth accepts no liability. Lubricant and metalworking fluids must be coordinated.

⚠ If environmental factors such as contamination, vibrations, impact loads, etc. are present, we recommend shorter lubrication intervals. Even under normal operating conditions, relubrication is required every 2 years due to grease aging.

- ▶ If your application involves more demanding environmental requirements (such as clean room, vacuum, food industry applications, increased exposure to fluids or aggressive media, extreme temperatures), please consult us. Each application must be considered on its own merits in order to choose the most appropriate lubricant. Special requirements call for special seals and wipers (see chapter "Ball runner block accessories"). Be sure to have all the information concerning your application at hand when contacting us. Pay attention to the chapter "Maintenance".
- ▶ Rexroth recommends piston distributors by SKF. These should be installed as close as possible to the lube fittings of the ball runner blocks. Long lines and small line diameters should be avoided, and the lines should be laid on an upward slant. Install the lines at a gradient.
- ▶ Refer to the chapter entitled "Ball runner block accessories" for a selection of possible lube ports (in this connection, contact the manufacturer of your lubrication system too).
- ▶ If other consumers are connected to the single-line lubrication system, the weakest link in this chain determines the lubrication cycle.

Notes on Dynalub

(Approved for EU countries only; not approved outside of the EU)

⚠ Pay attention to the allocation of the ball rail system.

Under conventional environmental conditions, this short-fibred, homogeneous grease is ideally suited for the lubrication of linear elements:

- ▶ With loads up to 50% C
- ▶ With short-stroke applications > 1 mm
- ▶ For the permissible speed range of ball rail systems

The product and material safety data sheet can be found on our website at: www.boschrexroth.com.

Dynalub 510

Grease lubricant

Features:

- ▶ Lithium-based, high-performance grease of grade NLGI 2 according to DIN 51818 (KP2K-20 according to DIN 51825)
- ▶ Good water resistance
- ▶ Corrosion protection
- ▶ Temperature range: -20 to +80 °C

Material numbers for Dynalub 510:

- ▶ R3416 037 00 (cartridge 400 g)
- ▶ R3416 035 00 (hobcock 25 kg)

Alternative greases:

- ▶ Castrol Tribol GR 100-2 PD*) or Elkalub GLS 135/N2*).

Notes on lubricant oil

We recommend **Shell Tonna S3 M 220** *) or similar products with the following properties:

- ▶ Special demulsifying oil CLP or CGLP as per DIN 51517-3 for machine bed tracks and tool guides
- ▶ A blend of highly refined mineral base oils and additives. Can be used even when mixed with significant quantities of metalworking fluids

*) No liability is accepted for changes to the product properties of these lubricants.

Dynalub 520

Liquid grease

Features:

- ▶ Lithium-based, high-performance grease of grade NLGI 00 according to DIN 51818 (GP00K-20 according to DIN 51826)
- ▶ Good water resistance
- ▶ Corrosion protection
- ▶ Temperature range: -20 to +80 °C

Material numbers for Dynalub 520:

- ▶ R3416 043 00 (cartridge 400 g)
- ▶ R3416 042 00 (bucket 5 kg)

Alternative greases:

- ▶ Castrol Tribol GR 100-00 PD*) or Elkalub GLS 135/N00*)

Lubrication

Grease lubrication with grease guns or progressive lubrication systems

▲ Observe chapter "Note on lubrication"

Grease lubricant: We recommend using **Dynalub 510**. For further information, please refer to chapter "Note on lubrication".

▲ Never put ball runner blocks into operation without basic lubrication. No initial lubrication is required if pre-lubricated at the factory. Rexroth ball rail systems are supplied with preservation.

Initial lubrication of the ball runner blocks (basic lubrication)

Stroke $\geq 2 \cdot$ ball runner block length B_1 (normal stroke)

- ▶ One lube connection per ball runner block, attach optionally on the left **or** right ball guide and lubricate!

The initial lubrication is done three times with the partial amount according to table 1:

1. Pre-lubricate the ball runner block with an initial partial amount according to table 1 by slowly applying pressure to the grease gun.
2. Move ball runner blocks with three double strokes of $3 \cdot$ ball runner block length B_1 .
3. Repeat steps 1 and 2 twice.
4. Check whether a film of grease is visible on the ball guide rail.

Stroke $< 2 \cdot$ ball runner block length B_1 (short stroke)

- ▶ Two lube connections per ball runner block, attach one connection on the left **and** right ball guide and lubricate!

The initial lubrication is done three times for each

connection with the partial amounts according to table 2:

1. Lubricate the ball runner block for each connection with an initial partial amount according to table 2 by slowly applying pressure to the grease gun.
2. Move ball runner blocks with three double strokes of $3 \cdot$ ball runner block length B_1 .
3. Repeat steps 1 and 2 twice.
4. Check whether a film of grease is visible on the ball guide rail.

Size	Initial lubrication (normal stroke)				
	Material numbers (not exhaustive)				
	(no initial lubrication)		(with initial lubrication)		
	R16.. ... 10	R20.. ... 04/0Z	R16.. ... 20/2Z	R20.. ... 30/3Z	R16.. ... 70/7Z
	R16.. ... 11	R20.. ... 05	R16.. ... 21	R20.. ... 31	R16.. ... 71
	R16.. ... 60	R20.. ... 06/0Y	R16.. ... 22/2Y	R20.. ... 32/3Y	R16.. ... 72/7Y
		R20.. ... 07	R16.. ... 23	R20.. ... 33	R16.. ... 73
	Partial amount (cm ³)				
15	0.4 (3x)				
20	0.7 (3x)				
25	1.4 (3x)				
30	2.2 (3x)				
35	2.2 (3x)				
45	-				
55	9.4 (3x)				
65	15.4 (3x)				
20/40	-				
25/70	-				
35/90	2.7 (3x)				

Table 1

Size	Initial lubrication (short stroke)				
	Material numbers (not exhaustive)				
	(no initial lubrication)		(with initial lubrication)		
	R16.. ... 10	R20.. ... 04/0Z	R16.. ... 20/2Z	R20.. ... 30/3Z	R16.. ... 70/7Z
	R16.. ... 11	R20.. ... 05	R16.. ... 21	R20.. ... 31	R16.. ... 71
	R16.. ... 60	R20.. ... 06/0Y	R16.. ... 22/2Y	R20.. ... 32/3Y	R16.. ... 72/7Y
		R20.. ... 07	R16.. ... 23	R20.. ... 33	R16.. ... 73
	left	right		R20.. ... 90	
15	0.4 (3x)	0.4 (3x)	-		
20	0.7 (3x)	0.7 (3x)	-		
25	1.4 (3x)	1.4 (3x)	-		
30	2.2 (3x)	2.2 (3x)	-		
35	2.2 (3x)	2.2 (3x)	-		
45	-		-		
55	9.4 (3x)	9.4 (3x)	-		
65	15.4 (3x)	15.4 (3x)	-		
20/40	-		-		
25/70	-		-		
35/90	2.7 (3x)	2.7 (3x)	-		

Table 2

Grease lubrication with grease guns or progressive lubrication systems (continued)

Relubrication of the ball runner blocks

Stroke $\geq 2 \cdot$ ball runner block length B_1 (normal stroke)

- ▶ When the relubrication interval in accordance with diagram 1 or 2  216 is reached, apply the relubrication quantity according to table 3.

Size	Relubrication (normal stroke)				
	Material numbers (not exhaustive)				
	R16.. ... 10	R20.. ... 04/0Z	R16.. ... 20/2Z	R20.. ... 30/3Z	R16.. ... 70/7Z
	R16.. ... 11	R20.. ... 05	R16.. ... 21	R20.. ... 31	R16.. ... 71
	R16.. ... 60	R20.. ... 06/0Y	R16.. ... 22/2Y	R20.. ... 32/3Y	R16.. ... 72/7Y
		R20.. ... 07	R16.. ... 23	R20.. ... 33	R16.. ... 73
				R20.. ... 90	
	Partial amount (cm ³)		Partial amount (cm ³)		
15	0.4 (1x)		0.4 (2x)		
20	0.7 (1x)		0.7 (2x)		
25	1.4 (1x)		1.4 (2x)		
30	2.2 (1x)		2.2 (2x)		
35	2.2 (1x)		2.2 (2x)		
45	-		4.7 (2x)		
55	9.4 (1x)				
65	15.4 (1x)		-		
20/40	-		1.0 (2x)		
25/70	-		1.4 (2x)		
35/90	2.7 (1x)		-		

Table 3

Stroke $< 2 \cdot$ ball runner block length B_1 (short stroke)

- ▶ When the relubrication interval according to diagram 1 or 2  216 is reached, apply the relubrication quantity according to table 4 **per** lube connection.
- ▶ For each lubrication cycle, the ball runner block should be moved with a double stroke of 3 ball runner block length B_1 ; as minimum stroke, however, ball runner block length B_1 should be moved.

Size	Relubrication (short stroke)				
	Material numbers (not exhaustive)				
	R16.. ... 10	R20.. ... 04/0Z	R16.. ... 20/2Z	R20.. ... 30/3Z	R16.. ... 70/7Z
	R16.. ... 11	R20.. ... 05	R16.. ... 21	R20.. ... 31	R16.. ... 71
	R16.. ... 60	R20.. ... 06/0Y	R16.. ... 22/2Y	R20.. ... 32/3Y	R16.. ... 72/7Y
		R20.. ... 07	R16.. ... 23	R20.. ... 33	R16.. ... 73
				R20.. ... 90	
	Partial amount per connection (cm ³)		Partial amount per connection (cm ³)		
	left	right	left	right	
15	0.4 (1x)	0.4 (1x)	0.4 (2x)	0.4 (2x)	
20	0.7 (1x)	0.7 (1x)	0.7 (2x)	0.7 (2x)	
25	1.4 (1x)	1.4 (1x)	1.4 (2x)	1.4 (2x)	
30	2.2 (1x)	2.2 (1x)	2.2 (2x)	2.2 (2x)	
35	2.2 (1x)	2.2 (1x)	2.2 (2x)	2.2 (2x)	
45	-		4.7 (2x)	4.7 (2x)	
55	9.4 (1x)	9.4 (1x)	-		
65	15.4 (1x)	15.4 (1x)	-		
20/40	-		1.0 (2x)	1.0 (2x)	
25/70	-		1.4 (2x)	1.4 (2x)	
35/90	2.7 (1x)	2.7 (1x)	-		

Table 4

Lubrication

Grease lubrication with grease guns or progressive lubrication systems (continued)

Load-dependent relubrication intervals

This applies to the following

conditions:

- ▶ Dynalub 510 grease or Castrol Tribol GR 100-2 PD or Elkalube GLS 135/N2
- ▶ No media pressurization
- ▶ Standard seals (SS)
- ▶ Ambient temperature: $T = 10 - 40 \text{ }^\circ\text{C}$

Key

- C = Dynamic load capacity (N)
- F_m = Dynamically equivalent Load on bearing (N)
- F_m/C = Load ratio (-)
- s = Relubrication interval as travel distance (km)

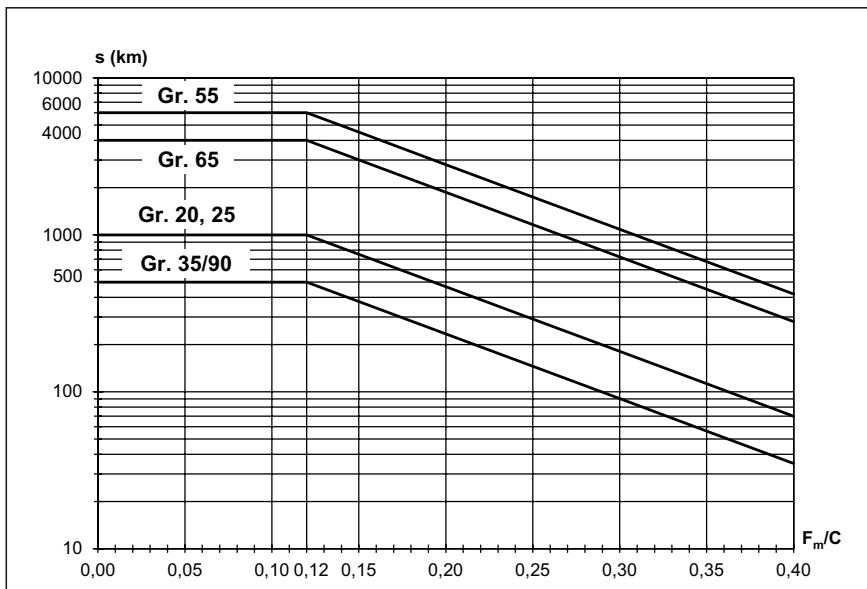

Diagram 1

Material number		
R16.. ... 10	R16.. ... 11	R16.. ... 60

For relubrication intervals, please consult us:

- ▶ In case of exposure to cooling lubricants
- ▶ In case of exposure to dust (wood, paper,...)
- ▶ With use of a double-lip seal (DS)
- ▶ With standard seal (SS) in combination with front seal or FKM seal or seal kit
- ▶ At low mean travel speed v_m
- ▶ At a raised ambient temperature
- ▶ At high loads $F_m/C > 0.4$

⚠ Pay attention to the notes on lubrication !

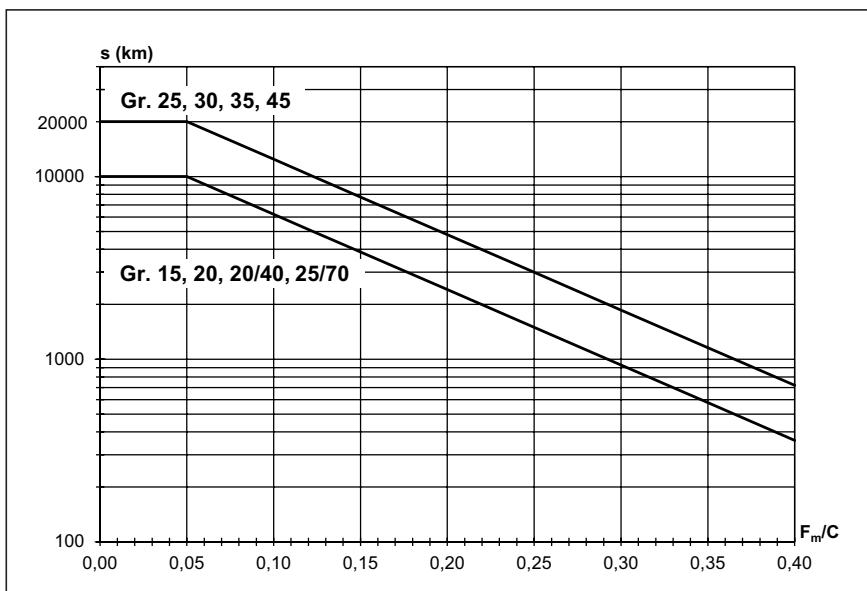

Diagram 2

Material number				
R20.. ... 04	R16.. ... 20	R20.. ... 30	R16.. ... 70	R20.. ... 90
R20.. ... 05	R16.. ... 21	R20.. ... 31	R16.. ... 71	
R20.. ... 06	R16.. ... 22	R20.. ... 32	R16.. ... 72	
R20.. ... 07	R16.. ... 23	R20.. ... 33	R16.. ... 73	

Liquid grease lubrication with single-line piston distributor systems

⚠ Observe chapter "Note on lubrication"

Grease lubricant: We recommend using **Dynalub 520**. For further information, please refer to chapter "Note on lubrication".

⚠ Never put ball runner blocks into operation without basic lubrication. No initial lubrication is required if pre-lubricated at the factory. Rexroth ball rail systems are supplied with preservation.

Initial lubrication of the ball runner blocks (basic lubrication)

Stroke ≥ 2 · ball runner block length B₁ (normal stroke)

- ▶ One lube connection per ball runner block, attach optionally on the left **or** right ball guide and lubricate!

The initial lubrication is done three times with the partial amounts according to table 5:

1. Lubricate the ball runner block with an initial partial amount according to table 5 by slowly applying pressure to the grease gun.
2. Move ball runner blocks with three double strokes of 3 · ball runner block length B₁.
3. Repeat steps 1 and 2 twice.
4. Check whether a film of grease is visible on the ball guide rail.

Stroke < 2 · ball runner block length B₁ (short stroke)

- ▶ Two lube connections per ball runner block, attach one connection on the left **and** right ball guide and lubricate!

The initial lubrication is done three times for each connection with the partial amounts according to table 6:

1. Lubricate the ball runner block for each connection with an initial partial amount according to table 6 by slowly applying pressure to the grease gun.
2. Move ball runner blocks with three double strokes of 3 · ball runner block length B₁.
3. Repeat steps 1 and 2 twice.
4. Check whether a film of grease is visible on the ball guide rail.

Size	Initial lubrication (normal stroke)				
	Material numbers (not exhaustive) (no initial lubrication)		Material numbers (not exhaustive) (with initial lubrication)		
	R16.. ... 10	R20.. ... 04/0Z	R16.. ... 20/2Z	R20.. ... 30/3Z	R16.. ... 70/7Z
	R16.. ... 11	R20.. ... 05	R16.. ... 21	R20.. ... 31	R16.. ... 71
	R16.. ... 60	R20.. ... 06/0Y	R16.. ... 22/2Y	R20.. ... 32/3Y	R16.. ... 72/7Y
		R20.. ... 07	R16.. ... 23	R20.. ... 33	R16.. ... 73
			R20.. ... 90		
	Partial amount (cm³)				
15	0.4 (3x)				
20	0.7 (3x)				
25	1.4 (3x)				
30	2.2 (3x)				
35	2.2 (3x)				
45	-				
55	9.4 (3x)				
65	15.4 (3x)				
20/40	-				
25/70	-				
35/90	2.7 (3x)				

Table 5

Size	Initial lubrication (short stroke)				
	Material numbers (not exhaustive) (no initial lubrication)		Material numbers (not exhaustive) (with initial lubrication)		
	R16.. ... 10	R20.. ... 04/0Z	R16.. ... 20/2Z	R20.. ... 30/3Z	R16.. ... 70/7Z
	R16.. ... 11	R20.. ... 05	R16.. ... 21	R20.. ... 31	R16.. ... 71
	R16.. ... 60	R20.. ... 06/0Y	R16.. ... 22/2Y	R20.. ... 32/3Y	R16.. ... 72/7Y
		R20.. ... 07	R16.. ... 23	R20.. ... 33	R16.. ... 73
			R20.. ... 90		
	Partial amount per connection (cm³)				
	left	right			
15	0.4 (3x)	0.4 (3x)	Initial lubrication in the factory with Dynalub 510		
20	0.7 (3x)	0.7 (3x)			
25	1.4 (3x)	1.4 (3x)			
30	2.2 (3x)	2.2 (3x)			
35	2.2 (3x)	2.2 (3x)			
45	-		-		
55	9.4 (3x)	9.4 (3x)			
65	15.4 (3x)	15.4 (3x)			
20/40	-		Initial lubrication in the factory with Dynalub 510		
25/70	-				
35/90	2.7 (3x)	2.7 (3x)	-		

Table 6

Lubrication

Liquid grease lubrication with single-line piston distributor systems (continued)

Relubrication of the ball runner blocks

Stroke $\geq 2 \cdot$ ball runner block length B_1 (normal stroke)

- ▶ If the relubrication interval according to diagram 3 or 4 has been reached, relubricate the amount stated in table 7.

Note

The number of pulses required for this purpose is the integer quotient of the minimum relubrication amount as per table 7 and the smallest permissible piston distributor size ($\hat{=}$ minimum pulse quantity) according to table 9. The smallest permissible piston distributor size also depends on the installation position.

The lubricating cycle time is the result of dividing the lubrication interval by the determined pulse count (see configuration example).

Stroke $< 2 \cdot$ ball runner block length B_1 (short stroke)

- ▶ When the relubrication interval according to diagram 3 or 4 is reached, apply the relubrication quantity according to table 8 **per** lube connection.
- ▶ The number of pulses required and the lubrication cycle are to be determined in a similar way as the relubrication (normal stroke).
- ▶ For each lubrication cycle, the ball runner block should be moved with a double stroke of 3 ball runner block length B_1 ; as minimum stroke, however, ball runner block length B_1 should be moved.

▲ Pay attention to the notes on lubrication !

Size	Relubrication (normal stroke)				
	Material numbers (not exhaustive)				
	R16.. ... 10	R20.. ... 04/0Z	R16.. ... 20/2Z	R20.. ... 30/3Z	R16.. ... 70/7Z
	R16.. ... 11	R20.. ... 05	R16.. ... 21	R20.. ... 31	R16.. ... 71
	R16.. ... 60	R20.. ... 06/0Y	R16.. ... 22/2Y	R20.. ... 32/3Y	R16.. ... 72/7Y
		R20.. ... 07	R16.. ... 23	R20.. ... 33	R16.. ... 73
				R20.. ... 90	
	Partial amount (cm ³)		Partial amount (cm ³)		
15	0.4 (1x)		0.4 (2x)		
20	0.7 (1x)		0.7 (2x)		
25	1.4 (1x)		1.4 (2x)		
30	2.2 (1x)		2.2 (2x)		
35	2.2 (1x)		2.2 (2x)		
45	-		4.7 (2x)		
55	9.4 (1x)				
65	15.4 (1x)		-		
20/40			1.0 (2x)		
25/70	-		1.4 (2x)		
35/90	2.7 (1x)		-		

Table 7

Size	Relubrication (short stroke)				
	Material numbers (not exhaustive)				
	R16.. ... 10	R20.. ... 04/0Z	R16.. ... 20/2Z	R20.. ... 30/3Z	R16.. ... 70/7Z
	R16.. ... 11	R20.. ... 05	R16.. ... 21	R20.. ... 31	R16.. ... 71
	R16.. ... 60	R20.. ... 06/0Y	R16.. ... 22/2Y	R20.. ... 32/3Y	R16.. ... 72/7Y
		R20.. ... 07	R16.. ... 23	R20.. ... 33	R16.. ... 73
				R20.. ... 90	
	Partial amount per connection (cm ³)		Partial amount per connection (cm ³)		
	left	right	left	right	
15	0.4 (1x)	0.4 (1x)	0.4 (2x)	0.4 (2x)	
20	0.7 (1x)	0.7 (1x)	0.7 (2x)	0.7 (2x)	
25	1.4 (1x)	1.4 (1x)	1.4 (2x)	1.4 (2x)	
30	2.2 (1x)	2.2 (1x)	2.2 (2x)	2.2 (2x)	
35	2.2 (1x)	2.2 (1x)	2.2 (2x)	2.2 (2x)	
45	-		4.7 (2x)	4.7 (2x)	
55	9.4 (1x)	9.4 (1x)			
65	15.4 (1x)	15.4 (1x)	-		
20/40			1.0 (2x)	1.0 (2x)	
25/70	-		1.4 (2x)	1.4 (2x)	
35/90	2.7 (1x)	2.7 (1x)	-		

Table 8

Liquid grease lubrication with single-line piston distributor systems (continued)

Load-dependent relubrication intervals

This applies to the following conditions:

- ▶ Liquid grease Dynalub 520, alternatively Castrol Tribol GR 100-00 PD or Elkalub GLS 135/N00
- ▶ no media pressurization
- ▶ Standard seals (SS)
- ▶ Ambient temperature: $T = 10 - 40 \text{ }^\circ\text{C}$

Key

- C = Dynamic load capacity (N)
- F_m = Dynamically equivalent Load on bearing (N)
- F_m/C = Load ratio (-)
- s = Relubrication interval as travel distance (km)

For relubrication intervals, please consult us:

- ▶ In case of exposure to cooling lubricants
- ▶ In case of exposure to dust (wood, paper,...)
- ▶ With use of a double-lip seal (DS)
- ▶ With standard seal (SS) in combination with front seal or FKM seal or seal kit
- ▶ At low mean travel speed v_m
- ▶ At a raised ambient temperature
- ▶ At high loads $F_m/C > 0.4$

⚠ Pay attention to the notes on lubrication !

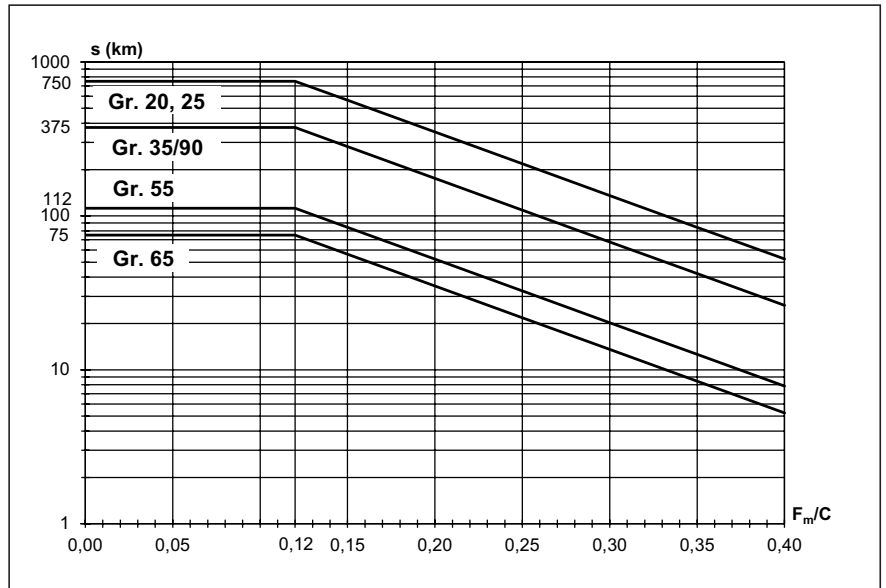

Diagram 3

Material number		
R16.. ... 10	R16.. ... 11	R16.. ... 60

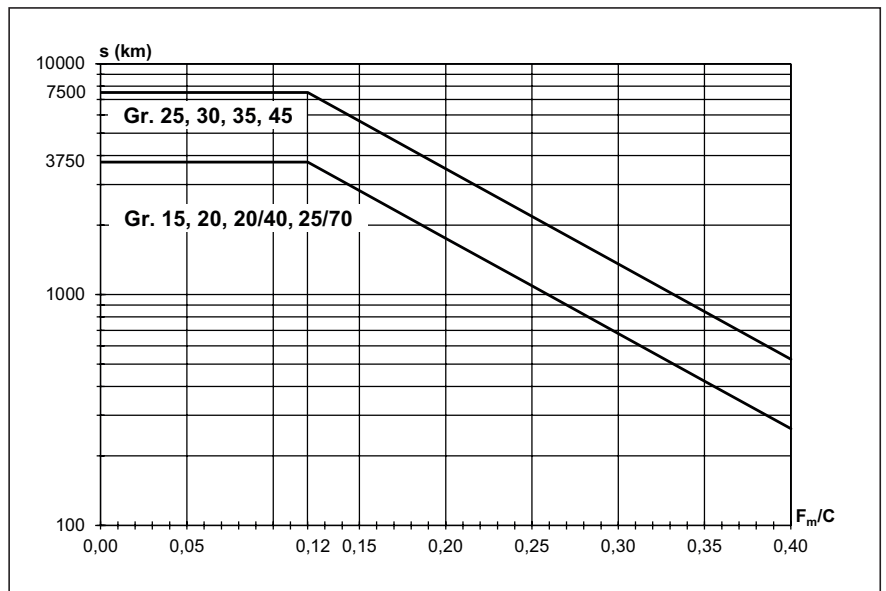
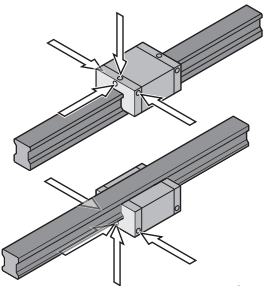
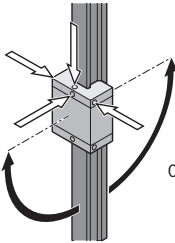
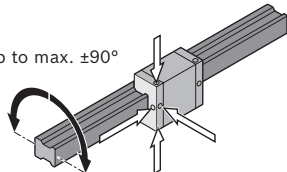
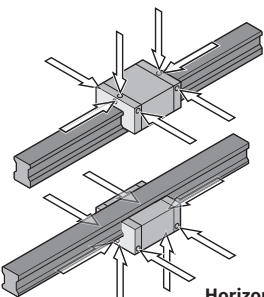
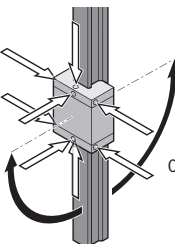
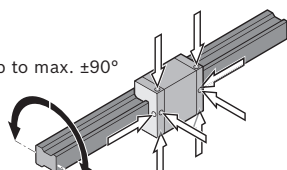

Diagram 4

Material number				
R20.. ... 04	R16.. ... 20	R20.. ... 30	R16.. ... 70	R20.. ... 90
R20.. ... 05	R16.. ... 21	R20.. ... 31	R16.. ... 71	
R20.. ... 06	R16.. ... 22	R20.. ... 32	R16.. ... 72	
R20.. ... 07	R16.. ... 23	R20.. ... 33	R16.. ... 73	

Lubrication

Liquid grease lubrication with single-line piston distributor systems (continued)

<p>Installation position I – normal stroke Horizontal 1 lube connection, either on the left or on the right ball guide</p>  <p style="text-align: right;">Horizontal over head Same connection</p>	<p>Installation position II – normal stroke Vertical to inclined horizontal 1 lube connection at the upper ball guide</p>  <p style="text-align: right;">Vertical to inclined over head Same connection</p>	<p>Installation position III – normal stroke Wall mounting 1 lube connection, either on the left or on the right ball guide</p>  <p style="text-align: right;">Same connection</p>
<p>Installation position IV – short stroke Horizontal 2 lube connections, 1 connection each on the left and right ball guide</p>  <p style="text-align: right;">Horizontal over head Same connections</p>	<p>Installation position V – short stroke Vertical to inclined horizontal 2 lube connections, 1 connection each on the top and bottom ball guide</p>  <p style="text-align: right;">Vertical to inclined over head Same connections</p>	<p>Installation position VI – short stroke Wall mounting 2 lube connections, 1 connection each on the left and right ball guide</p>  <p style="text-align: right;">Same connections</p>

Smallest permissible piston distributor size for liquid grease lubrication via single-line piston distributor¹⁾

Ball runner blocks				Smallest permissible piston distributor size (≅ minimum pulse quantity) for each connection (cm ³) with liquid grease of grade NLGI 00										
				Material number		Installation positions	Size							
			15	20	25		30	35	45	55	65	20/40	25/70	35/90
R16.. ... 10		Horizontal I, IV Vertical II, V Wall mounting III, VI	-	0.30	0.30	-	-	-	0.30	0.30	-	-	0.30	
R16.. ... 11														
R16.. ... 60														
R20.. ... 04	R16.. ... 20	R20.. ... 30	R16.. ... 70	0.03	0.03	0.03	0.06	0.10	0.10	-	0.03	0.03	-	
R20.. ... 0Z	R16.. ... 2Z	R20.. ... 3Z	R16.. ... 7Z											
R20.. ... 05	R16.. ... 21	R20.. ... 31	R16.. ... 71											
R20.. ... 06	R16.. ... 22	R20.. ... 32	R16.. ... 72											
R20.. ... 0Y	R16.. ... 2Y	R20.. ... 3Y	R16.. ... 7Y											
R20.. ... 07	R16.. ... 23	R20.. ... 33	R16.. ... 73											
		R20.. ... 90												

Table 9

1) This applies to the following conditions:

- Liquid grease Dynalub 520 (alternatively Castrol Tribol GR 100-00 PD or Elkalube GLS 135/N00) and piston distributors from SKF
- Lubrication channels must be filled
- Ambient temperature T = 10 – 40 °C

Oil lubrication with single-line piston distributor systems

⚠ Observe chapter "Note on lubrication"

Lubricant oil: We recommend **Shell Tonna S3 M220**. For further information, please refer to chapter "Note on lubrication".

⚠ Never put ball runner blocks into operation without basic lubrication. No initial lubrication is required if pre-lubricated at the factory. Rexroth ball rail systems are supplied with preservation.

Initial lubrication of the ball runner blocks (basic lubrication)

Stroke $\geq 2 \cdot$ ball runner block length B_1 (normal stroke)

- ▶ One lube connection per ball runner block, attach optionally on the left **or** right ball guide and lubricate!

The initial lubrication is done two times with the partial amount according to table 10:

1. Oil the ball runner block with the initial partial amount according to table 10.
2. Move ball runner blocks with three double strokes of $3 \cdot$ ball runner block length B_1 .
3. Repeat steps 1 and 2 once.
4. Check whether a film of grease is visible on the ball guide rail.

Stroke $< 2 \cdot$ ball runner block length B_1 (short stroke)

- ▶ Two lube connections per ball runner block, attach one connection on the left **and** right ball guide and lubricate!

The initial lubrication is done two times for each connection with the partial amounts according to table 11:

1. Oil the ball runner block for each connection with the initial partial amount according to table 11.
2. Move ball runner blocks with three double strokes of $3 \cdot$ ball runner block length B_1 .
3. Repeat steps 1 and 2 once.
4. Check whether a film of grease is visible on the ball guide rail.

Size	Initial lubrication (normal stroke)				
	Material numbers (not exhaustive) (no initial lubrication)		(with initial lubrication)		
	R16.. ... 10	R20.. ... 04/0Z	R16.. ... 20/2Z	R20.. ... 30/3Z	R16.. ... 70/7Z
	R16.. ... 11	R20.. ... 05	R16.. ... 21	R20.. ... 31	R16.. ... 71
	R16.. ... 60	R20.. ... 06/0Y	R16.. ... 22/2Y	R20.. ... 32/3Y	R16.. ... 72/7Y
		R20.. ... 07	R16.. ... 23	R20.. ... 33	R16.. ... 73
	Partial amount (cm ³)				
15	0.4 (2x)		Initial lubrication in the factory with Dynalub 510		
20	0.7 (2x)				
25	1.0 (2x)				
30	1.1 (2x)				
35	1.2 (2x)				
45	-		-		
55	3.6 (2x)				
65	6.0 (2x)				
20/40	-		Initial lubrication in the factory with Dynalub 510		
25/70	-				
35/90	1.8 (2x)		-		

Table 10

Size	Initial lubrication (short stroke)				
	Material numbers (not exhaustive) (no initial lubrication)		(with initial lubrication)		
	R16.. ... 10	R20.. ... 04/0Z	R16.. ... 20/2Z	R20.. ... 30/3Z	R16.. ... 70/7Z
	R16.. ... 11	R20.. ... 05	R16.. ... 21	R20.. ... 31	R16.. ... 71
	R16.. ... 60	R20.. ... 06/0Y	R16.. ... 22/2Y	R20.. ... 32/3Y	R16.. ... 72/7Y
		R20.. ... 07	R16.. ... 23	R20.. ... 33	R16.. ... 73
	Partial amount per connection (cm ³)				
	left	right			
15	0.4 (2x)	0.4 (2x)	Initial lubrication in the factory with Dynalub 510		
20	0.7 (2x)	0.7 (2x)			
25	1.0 (2x)	1.0 (2x)			
30	1.1 (2x)	1.1 (2x)			
35	1.2 (2x)	1.2 (2x)			
45	-		-		
55	3.6 (2x)	3.6 (2x)			
65	6.0 (2x)	6.0 (2x)			
20/40	-		Initial lubrication in the factory with Dynalub 510		
25/70	-				
35/90	1.8 (2x)	1.8 (2x)	-		

Table 11

Lubrication

Oil lubrication with single-line piston distributor systems (continued)

Relubrication of the ball runner blocks

Stroke $\geq 2 \cdot$ ball runner block length B_1 (normal stroke)

- ▶ If the relubrication interval according to diagram 5 or 6 has been reached, relubricate the amount stated in table 12.

Note

The number of pulses required is the integer quotient of the minimum relubrication amount as per table 12 and the smallest permissible piston distributor size ($\hat{=}$ minimum pulse quantity) according to table 14.

The smallest permissible piston distributor size also depends on the installation position. The lubricating cycle time is the result of dividing the lubrication interval by the determined pulse count (see configuration example).

Size	Relubrication (normal stroke)				
	Material numbers (not exhaustive)				
	R16.. ... 10	R20.. ... 04/0Z	R16.. ... 20/2Z	R20.. ... 30/3Z	R16.. ... 70/7Z
	R16.. ... 11	R20.. ... 05	R16.. ... 21	R20.. ... 31	R16.. ... 71
	R16.. ... 60	R20.. ... 06/0Y	R16.. ... 22/2Y	R20.. ... 32/3Y	R16.. ... 72/7Y
		R20.. ... 07	R16.. ... 23	R20.. ... 33	R16.. ... 73
				R20.. ... 90	
	Partial amount (cm ³)		Partial amount (cm ³)		
15	0.4 (1x)		0.4 (1x)		
20	0.7 (1x)		0.7 (1x)		
25	1.0 (1x)		1.0 (1x)		
30	1.1 (1x)		1.1 (1x)		
35	1.2 (1x)		1.2 (1x)		
45	-		2.2 (1x)		
55	3.6 (1x)				
65	6.0 (1x)		-		
20/40			0.7 (1x)		
25/70	-		1.1 (1x)		
35/90	1.8 (1x)		-		

Table 12

Stroke $< 2 \cdot$ ball runner block length B_1 (short stroke)

- ▶ When the relubrication interval according to diagram 5 or 6 is reached, apply the relubrication quantity according to table 13 **per** lube connection.
- ▶ The number of pulses required and the lubrication cycle are to be determined in a similar way as the relubrication (normal stroke).
- ▶ For each lubrication cycle, the ball runner block should be moved with a double stroke of 3 ball runner block length B_1 ; as minimum stroke, however, ball runner block length B_1 should be moved.

Size	Relubrication (short stroke)			
	Material numbers (not exhaustive)			
	R16.. ... 10	R20.. ... 04/0Z	R16.. ... 20/2Z	R20.. ... 30/3Z
	R16.. ... 11	R20.. ... 05	R16.. ... 21	R20.. ... 31
	R16.. ... 60	R20.. ... 06/0Y	R16.. ... 22/2Y	R20.. ... 32/3Y
		R20.. ... 07	R16.. ... 23	R20.. ... 33
				R20.. ... 90
	Partial amount per connection (cm ³)		Partial amount per connection (cm ³)	
	left	right	left	right
15	0.4 (1x)	0.4 (1x)	0.4 (1x)	0.4 (1x)
20	0.7 (1x)	0.7 (1x)	0.7 (1x)	0.7 (1x)
25	1.0 (1x)	1.0 (1x)	1.0 (1x)	1.0 (1x)
30	1.1 (1x)	1.1 (1x)	1.1 (1x)	1.1 (1x)
35	1.2 (1x)	1.2 (1x)	1.2 (1x)	1.2 (1x)
45	-		2.2 (1x)	2.2 (1x)
55	3.6 (1x)	3.6 (1x)	-	
65	6.0 (1x)	6.0 (1x)		
20/40			0.7 (1x)	0.7 (1x)
25/70	-		1.1 (1x)	1.1 (1x)
35/90	1.8 (1x)	1.8 (1x)	-	

Table 13

⚠ Pay attention to the notes on lubrication !

Oil lubrication with single-line piston distributor systems (continued)

Load-dependent relubrication intervals for oil lubrication via single-line piston distributor systems ("dry axes")

This applies to the following conditions:

- ▶ Lubricant oil Shell Tonna S3 M220
- ▶ No media pressurization
- ▶ Standard seals (SS)
- ▶ Ambient temperature:
T = 10 – 40 °C

Key

- C = Dynamic load capacity (N)
- F_m = Dynamically equivalent load on bearing (N)
- F_m/C = Load ratio (-)
- s = Relubrication interval as travel distance (km)

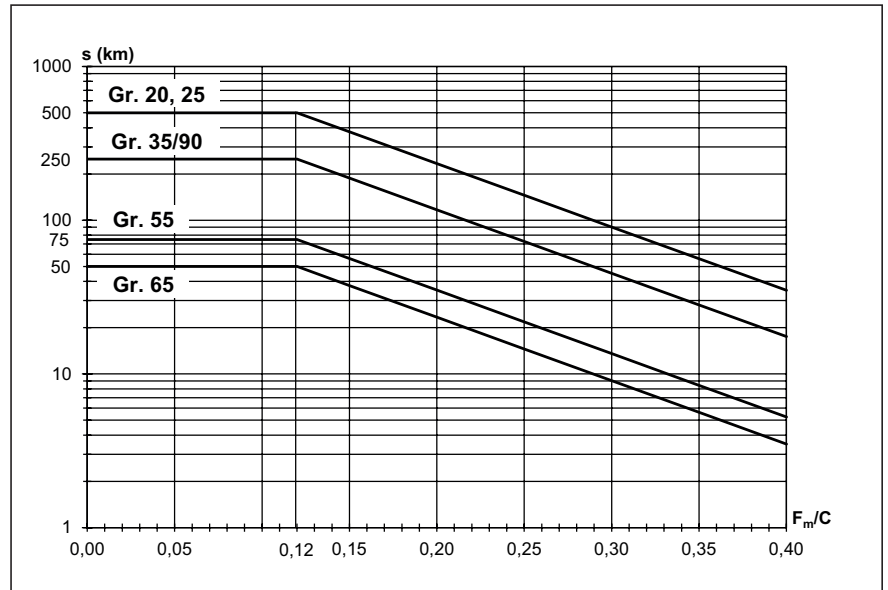

Diagram 5

Material number		
R16.. ... 10	R16.. ... 11	R16.. ... 60

For relubrication intervals, please consult us:

- ▶ In case of exposure to cooling lubricants
- ▶ In case of exposure to dust (wood, paper,...)
- ▶ With use of a double-lip seal (DS)
- ▶ With standard seal (SS) in combination with front seal or FKM seal or seal kit
- ▶ At low mean travel speed v_m
- ▶ At a raised ambient temperature
- ▶ At high loads F_m/C > 0.4

⚠ Pay attention to the notes on lubrication !

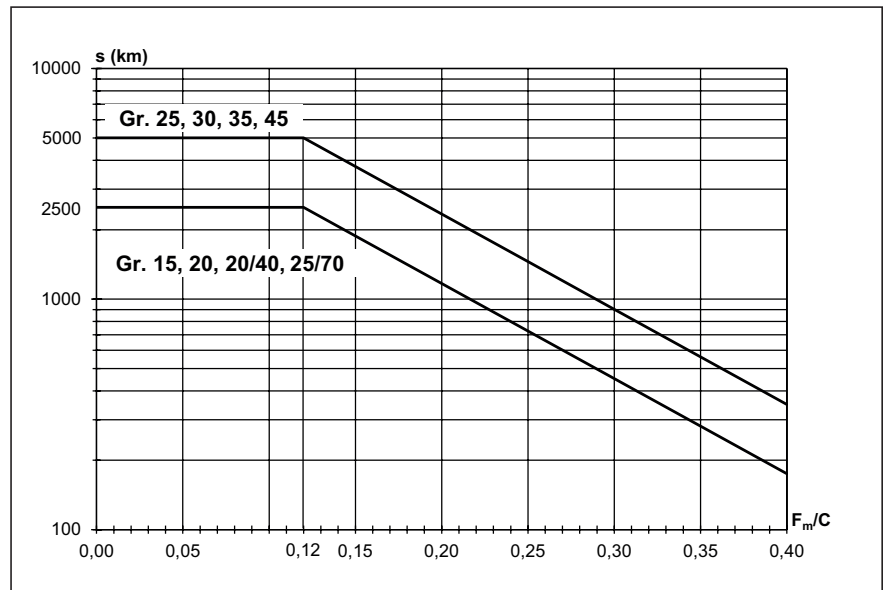

Diagram 6

Material number				
R20.. ... 04	R16.. ... 20	R20.. ... 30	R16.. ... 70	R20.. ... 90
R20.. ... 05	R16.. ... 21	R20.. ... 31	R16.. ... 71	
R20.. ... 06	R16.. ... 22	R20.. ... 32	R16.. ... 72	
R20.. ... 07	R16.. ... 23	R20.. ... 33	R16.. ... 73	

Lubrication

Oil lubrication with single-line piston distributor systems (continued)

Installation position I – normal stroke
Horizontal
 1 lube connection, either on the left **or** on the right ball guide

Horizontal over head
 Same connection

Installation position II – normal stroke
Vertical to inclined horizontal
 1 lube connection at the upper ball guide

Vertical to inclined over head
 Same connection

Installation position III – normal stroke
Wall mounting
 1 lube connection, either on the left **or** on the right ball guide

0° up to max. ±90°

Same connection

Installation position IV – short stroke
Horizontal
 2 lube connections, 1 connection each on the left **and** right ball guide

Horizontal over head
 Same connections

Installation position V – short stroke
Vertical to inclined horizontal
 2 lube connections, 1 connection each on the top **and** bottom ball guide

Vertical to inclined over head
 Same connections

Installation position VI – short stroke
Wall mounting
 2 lube connections, 1 connection each on the left **and** right ball guide

0° up to max. ±90°

Same connections

Smallest permissible piston distributor size for oil lubrication via single-line piston distributor¹⁾

Ball runner blocks				Smallest permissible piston distributor size (≠ minimum pulse quantity) for each connection (cm ³) with oil viscosity of 220 m ² /s											
				Size											
Material number				Installation positions	15	20	25	30	35	45	55	65	20/40	25/70	35/90
R16.. ... 10				Horizontal I, IV	-	0.60					1.50		-		0.60
R16.. ... 11				Vertical II, V											
R16.. ... 60				Wall mounting III, VI											
R20.. ... 04	R16.. ... 20	R20.. ... 30	R16.. ... 70	Horizontal I, IV	0.03	0.03	0.03	0.06	0.10	0.10			0.03	0.03	
R20.. ... 0Z	R16.. ... 2Z	R20.. ... 3Z	R16.. ... 7Z	Vertical II, V											
R20.. ... 05	R16.. ... 21	R20.. ... 31	R16.. ... 71	Wall mounting III, VI											
R20.. ... 06	R16.. ... 22	R20.. ... 32	R16.. ... 72												
R20.. ... 0Y	R16.. ... 2Y	R20.. ... 3Y	R16.. ... 7Y												
R20.. ... 07	R16.. ... 23	R20.. ... 33	R16.. ... 73												
		R20.. ... 90													

Table 14

- 1) This applies to the following conditions:
- Lubricant oil Shell Tonna S3 M 220 and piston distributor from SKF
 - Lubrication channels must be filled
 - Ambient temperature T = 10 – 40 °C

Configuration example of lubrication of a typical 2-axes application using central lubrication

X-axis

Component or characteristic value	Specifications
Ball runner blocks	Size 35, 4 pieces, C = 51,800 N, material numbers: R1651 323 20
Ball guide rail	Size 35, 2 pieces, L = 1,500 mm; material numbers: R1605 333 61
Dynamically equivalent load on bearing	$F_m = 12,570$ N (per ball runner block) with consideration of the preload (here C2)
Stroke	500 mm
Average linear speed	$v_m = 1$ m/s
Temperature	20 - 30 °C
Installation position	Horizontal
Lubrication	Single-line distributor system for all axes with liquid grease Dynalub 520
Exposure to contaminants	No exposure to media, chips, dust

Configuration sizes

1. Normal stroke or short stroke?

Configuration (for each ball runner block)

Normal stroke:
 Stroke $\geq 2 \cdot$ ball runner block length B_1
 $500 \text{ mm} \geq 2 \cdot 77 \text{ mm}$
 $500 \text{ mm} \geq 154 \text{ mm!}$
 i.e. normal stroke applies!

Sources of information

► Normal stroke formula, ball runner block length B_1

2. Initial lubrication amount

1 lube connection, initial lubrication quantity: Pre-lubricated at the factory with Dynalub 510

► Initial lubrication amount from table 5

3. Relubrication quantity

1 lube connection, relubrication quantity: 2.2 cm^3 (2x)

► Relubrication amount from table 7

4. Installation position

Installation position I – normal stroke (horizontal)

► Installation position from overview

5. Piston distributor size

Permissible piston distributor size: 0.1 cm^3

► Piston distributor size from table 9 size 35, installation position I (horizontal)

6. Number of pulses

$$\text{Number of pulses} = \frac{2 \cdot 2.2 \text{ cm}^3}{0.1 \text{ cm}^3} = 44$$

$$\text{Number of pulses} = \frac{\text{Number} \cdot \text{relubrication quantity}}{\text{Permissible Piston distributor size}}$$

7. Load ratio

$$\text{Load ratio} = \frac{12570 \text{ N}}{51800 \text{ N}} = 0.24$$

► Load ratio = F_m/C
 F_m and C from specifications

8. Relubrication interval

Relubrication interval: 2150 km

► Relubrication interval from diagram 4:
 Curve size 35 with load ratio of 0.24

9. Lubrication cycle

$$\text{Lubrication cycle} = \frac{2150 \text{ km}}{44} = 48$$

$$\text{Lubrication cycle} = \frac{\text{Relubrication interval}}{\text{Number of pulses}}$$

Interim result (X-axis)

For the x-axis, for each ball runner block, a minimum quantity of 0.1 cm^3 of Dynalub 520 is to be supplied every 48 km.

Lubrication

Y-axis

Component or characteristic value	Specifications
Ball runner blocks	Size 25, 4 pieces, C = 28600 N, material numbers: R1651 223 20
Ball guide rail	Size 25, 2 pieces, L = 1000 mm; material numbers: R1605 232 31
Dynamically equivalent load on bearing	$F_m = 3,420$ N (per ball runner block) with consideration of the preload (here C2)
Stroke	50 mm (short stroke)
Average linear speed	$v_m = 1$ m/s
Temperature	20 – 30 °C
Installation position	Vertical
Lubrication	Single-line distributor system for all axes with liquid grease Dynalub 520
Exposure to contaminants	No exposure to media, chips, dust

Configuration sizes

1. Normal stroke or short stroke?

Configuration (for each ball runner block)

Normal stroke:
 Stroke $\geq 2 \cdot$ ball runner block length B_1
 50 mm $\geq 2 \cdot 57.8$ mm
 50 mm < 115.6 mm!
 i.e. short stroke applies!

Sources of information

► Normal stroke formula, ball runner block length B_1

2. Initial lubrication amount

2 lube connections, initial lubrication quantity for each connection: pre-lubricated at the factory with Dynalub 510

► Initial lubrication amount from table 6

3. Relubrication quantity

2 lube connections, relubrication quantity for each connection: 1.4 cm³ (2x)

► Relubrication amount from table 8

4. Installation position

Installation position V - short stroke (vertical to inclined horizontal)

► Installation position from overview

5. Piston distributor size

Permissible piston distributor size: 0.03 cm³

► Piston distributor size from table 9, size 25, installation position V (vertical to inclined horizontal)

6. Number of pulses

$$\text{Number of pulses} = \frac{2 \cdot 1.4 \text{ cm}^3}{0.03 \text{ cm}^3} = 94$$

$$\text{Pulse number} = \frac{\text{Number} \cdot \text{relubrication quantity}}{\text{Permissible Piston distributor size}}$$

7. Load ratio

$$\text{Load ratio} = \frac{3420 \text{ N}}{28600 \text{ N}} = 0.12$$

► Load ratio = F_m/C
 F_m and C from specifications

8. Relubrication interval

Relubrication interval: 7500 km

► Relubrication interval from diagram 4: Curve size 25 with load ratio of 0.12

9. Lubrication cycle

$$\text{Lubrication cycle} = \frac{7500 \text{ km}}{94} = 80 \text{ km}$$

$$\text{Lubrication cycle} = \frac{\text{Relubrication interval}}{\text{Number of pulses}}$$

Interim result (Y-axis)

For the y-axis, for each ball runner block and each lube connection, a minimum quantity of 0.03 cm³ of Dynalub 520 is to be supplied every 80 km.

Final result (two-axes lubrication)

Since, in this example, both axes are to be supplied by a single-line distributor system, the x-axis with its smaller lubrication cycle (48 km) determines the total lubrication cycle of the system, i.e. the y-axis is lubricated every 48 km as well.

The number of connections and minimum quantities determined for each individual axis remain valid.

**Lubrication from above
without lubrication adapter**

For all ball runner blocks with preparation for lubrication from above.

(Exceptions: Ball runner block high SNH R1621 and SLH R1624)

In the groove for the o-ring, another small groove (1) is pre-fitted. Do not open this with a drill.

Risk of contamination!

1. Heat up a metal tip (2) with a diameter of 0.8 mm.
2. Carefully open and pierce the groove (1) with the metal tip. Observe the maximum permissible depth T_{max} according to the table!
3. Insert the o-ring (3) into the groove (the o-ring is not included in the scope of delivery of the ball runner block. Ball runner block accessories)

with lubrication adapter

(Ball runner block accessories)

A lubrication adapter is necessary for high ball runner blocks if lubrication is to be carried out from the carriage.

In the groove for the o-ring, another small groove (1) is pre-fitted. Do not open this with a drill.

Risk of contamination!

1. Heat up a metal tip (2) with a diameter of 0.8 mm.
2. Carefully open and pierce the groove (1) with the metal tip. Observe the maximum permissible depth T_{max} according to the table!
3. Insert the o-ring (3) into the groove (the o-ring is not included in the scope of delivery of the lubrication adapter).
4. Insert the lubrication adapter at a slant into the groove and press the straight side (4) against the steel part (5). Use grease to fix the adapter in place.
5. Insert the o-ring (6) into the lubrication adapter (the o-ring is not included in the scope of delivery of the lubrication adapter).

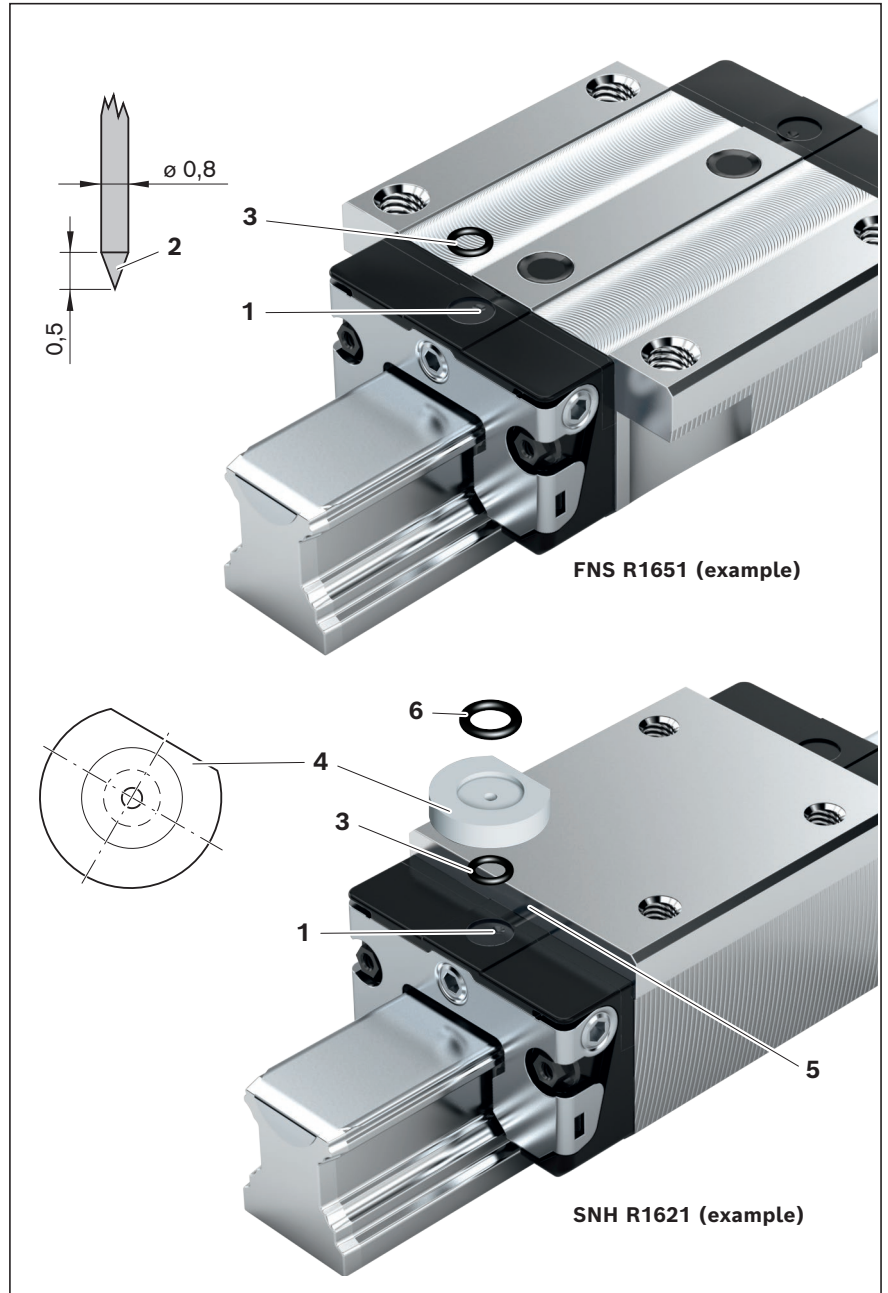

Size	Lubrication opening, top: Maximum permissible depth for piercing T_{max} (mm)	
	Ball runner block standard height/high	Ball runner block low
15	3.6	-
20	3.9	4.4
25	3.3	4.9
30	6.6	-
35	7.5	-
45	8.8	-
20/40	4.0	-
25/70	2.1	-
35/90	7.9	-

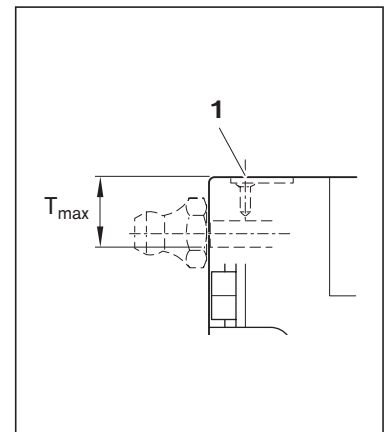

Maintenance

Cleaning cycle

Dirt can settle and encrust on ball guide rails, especially when these are not enclosed. To ensure that seals and cover strips retain their functionality, this contamination must be removed at regular intervals.

It is advisable to perform at least one full cleaning cycle over the entire travel range at least twice a day or every 8 hours at the latest.

Before shutting down the machine, always perform a cleaning cycle.

Shorter maintenance intervals in case of exposure to cooling lubricants.

Maintenance of accessories

All accessories used for scraping the ball guide rail shall be subject to regular maintenance.

In environments with heavy contamination, it is advisable to replace all the parts directly exposed to such contamination.

We recommend annual maintenance.